

YFW 400 TUH

Thermally Broken, Impact Resistant and Blast Mitigating Fixed Window

ProTek



YKK AP Hurricane & Blast Solutions

Integrated Superior Protection

The YFW 400 TUH ProTek® thermally broken impact resistant and blast mitigating fixed windows have been designed and engineered to the highest of standards. The quality 4" frame depth fixed window is universal to our 4" depth impact resistant operable window systems. This fixed window system will easily integrate with our YVS 410 TUH Single Hung window system utilizing the same stacking mullions. Integral horizontal and vertical mullions provide greatly expanded configurations.

Superior air and water performance enhance this factory glazed product making it an excellent substitution for smaller storefront punched openings.

The YFW 400 TUH is a high performance window that is designed for the high velocity winds of south Florida. Additional benefit is provided by the labor savings when used as a factory glazed fixed window.

This window system not only provides additional security against burglary but also the minimal hazard level of ASTM F 1642 for blast mitigation.



YKK
aP

Quality
inspires®



YFW 400 TUH

SYSTEM SPECIFICATIONS

System Sightline	Base Depth	Glazing & Config	Glass	Air Infiltration	Water Infiltration	Thermal Performance	Acoustical Performance
2"	4"	Pre-Glazed & Fixed	1" Lam IGU with Low-E (C.O.G. U-factor: 0.29)	0.30 CFM/FT ² (16.5 m ³ /h·m ²)	Static: 15 PSF (719 Pa)	U-factor: 0.40 BTU/HR·FT ² ·°F* CRF: Minimum of 67 on frame**	Lam STC: 38 Lam OITC: 30
Testing Standards				ASTM E 283	ASTM E 331 & AAMA 501	* NFRC 102 & ** AAMA 1503	ASTM E 90 & 1425
Florida Product Approvals				Large and Small Missile, HVHZ, ICC Compliant, AW Performance Grade 100 for Fixed Window			
Available Finishes				Factory Anodized (AAMA 612) and Organic Paints (AAMA 2605)			

MULLION OPTIONS

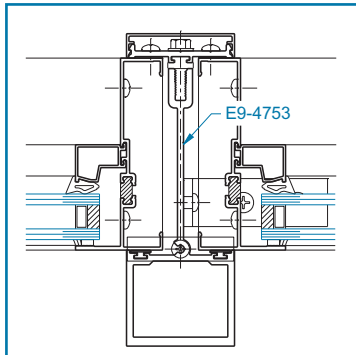
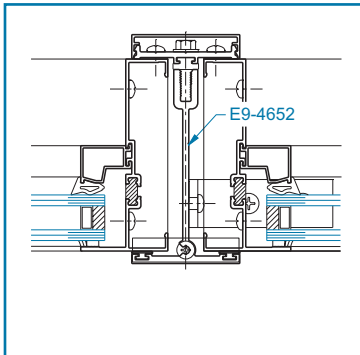

FEATURES & BENEFITS

- Certified AAMA Performance Grade: AW-PG100-FW
- ThermaBond Plus® Thermal Break
- 1" Insulating Glazing or Insulating Panels
- Vertical and Horizontal Stacking Mullion Options
- Box Trim, Sill Flashing, Panning, and Multiple Anchor Options
- Large Missile is Wet Glazed, Small is Dry Glazed
- ASTM E 1886/1996, TAS 201, 202, & 203
 - Meets ICC Requirements, Florida State-Wide Approval – High Velocity Hurricane Zone (HVHZ)
 - Tested to +90psf/ -120psf
- Blast Mitigation; "Minimal Hazard" per ASTM F 1642 Test @ 6psi / 41 psi-ms

CONFIGURATIONS & FEATURES

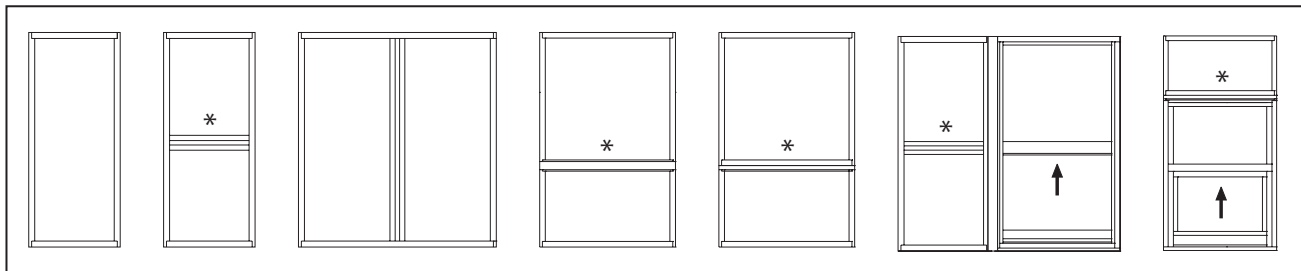

* Integral Horizontal Mullion is NOT impact resistant, but is blast mitigated.

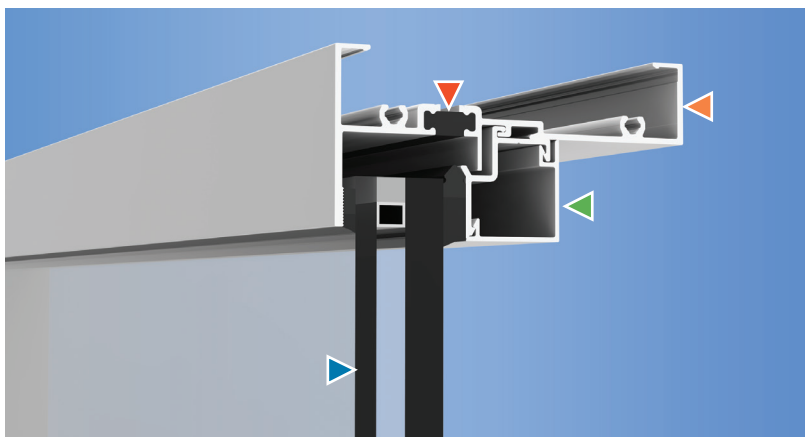

YFW 400 TUH Design Features

- ▶ Equal Legs on Frame for Easy Installation in New Construction or Renovations
- ▶ Interlocking Mechanically Fastened Aluminum Bead Glazing (LMI Wet/SM Dry)
- ▶ ThermaBond Plus® Thermal Break for Superior Thermal Performance
- ▶ 1" Glazing – IGU's or Insulating Panels

Additional information including CAD details, CSI specifications, Test Reports and Installation instructions are available online at:
www.ykkap.com/commercial/product/architectural-windows/yfw-400-tuh/