

YWW 45 FI

High Performance Window Wall System with Insulating Glass

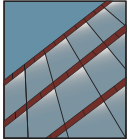

WINDOW WALL SYSTEM

Product Description

The YWW 45 FI is designed specifically to meet the performance requirements of window walls for multi-story buildings. Glass is set to the front of the system to maximize thermal performance and maybe glazed from either the interior of the building for labor savings or from the exterior at column line applications. The YWW 45 FI may be installed with head and sill members running continuously or with the head and sill members cut in between the vertical members. Sill flashing is only required when the head and sill members are cut in between the verticals.

Product Options & Features

- Perimeter Members: 2" x 4-1/2"
- Intermediate Members: 2-1/4" x 4-1/2"
- Screw Spline or Shear Block Construction
- Optional SSG Intermediate Vertical
- Strap & Roll-Over Anchors are available for Precast Conditions

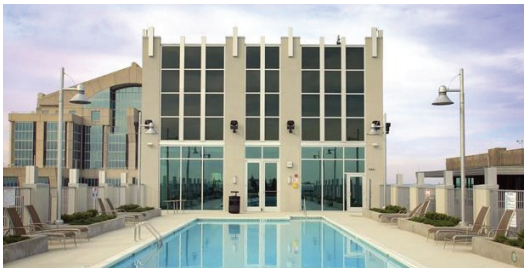

YKK
ap®

Quality
inspires®

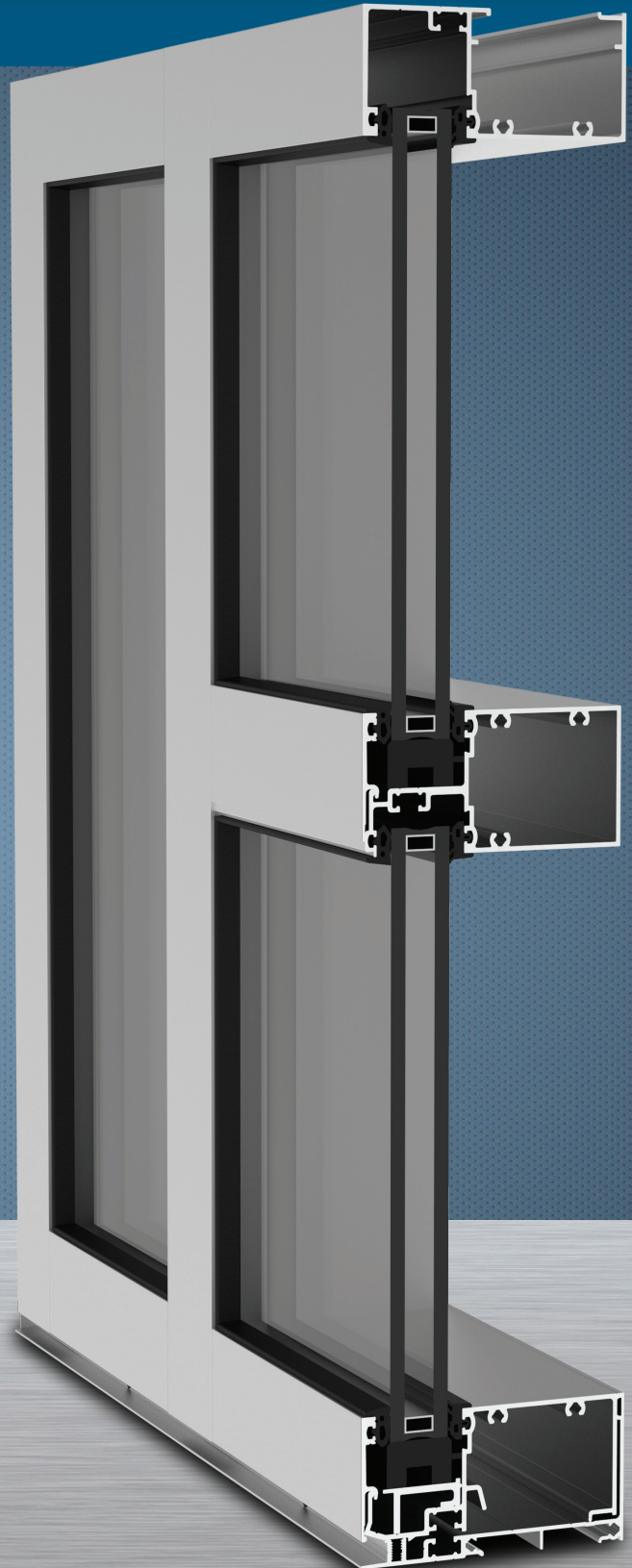

YWW 45 FI

SYSTEM SPECIFICATIONS

System Sightline	Base Depth	Glazing & Config	Glass	Air Infiltration	Water Infiltration	Thermal Performance	Acoustical Performance
2" Perimeter 2-1/4" Intermediate	4-1/2"	Outside or Inside & Front Set	1" IGU with Low-E (C.O.G. U-factor: 0.29)	0.06 CFM/FT ² (1.10 m ³ /h·m ²) @ 6.24 PSF (299 Pa)	Static: 12 PSF (575 Pa) Dynamic: 12 PSF (575 Pa)	U-factor: 0.40 BTU/HR•FT ² •°F* CRF: Minimum of 69 on frame**	Lam STC: 35 Lam OITC: 29
Testing Standards				ASTM E 283	ASTM E 331 & AAMA 501	* NFRC 102 & ** AAMA 1503	ASTM E 90 & 1425
Installation Options				Continuous Head & Sill, Vertical Through, Shear Block or Screw Spline with Monolithic or Insulating Glass			
Available Finishes				Factory Anodized (AAMA 612) and Organic Paints (AAMA 2604 & AAMA 2605)			

SSG OPTION

Not only can the system be inside or outside glazed, but the system also supports Structural Silicone Glazing (SSG).

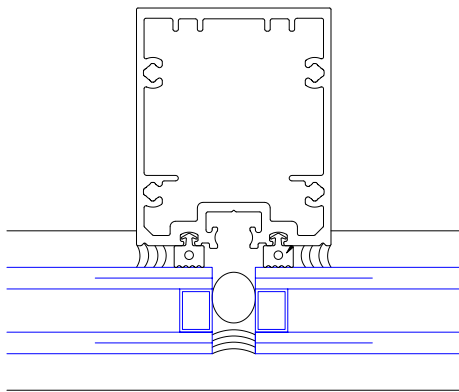

Outside Glazed SSG with 1" Glass

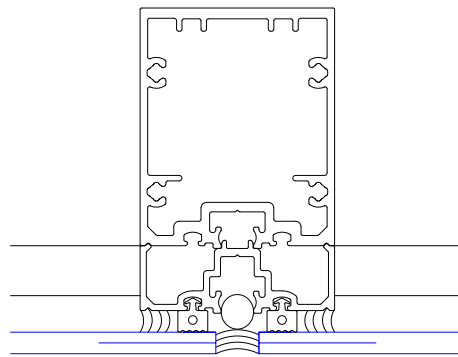

Outside Glazed SSG with 1/4" Adapter

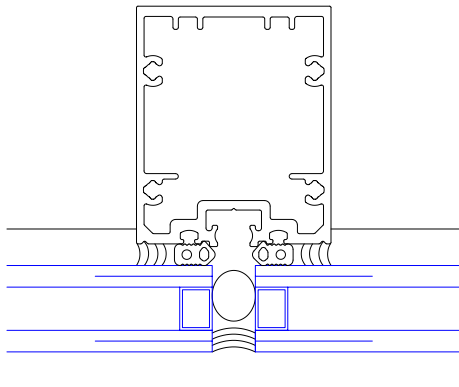

Inside Glazed SSG with 1" Glass

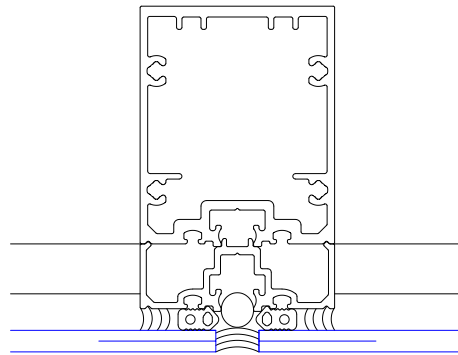

Inside Glazed SSG with 1/4" Adapter

Additional information including CAD details, CSI specifications, Test Reports and Installation instructions are available online at:

www.ykkap.com/commercial/product/window-walls/yww-45-fi/