

ThermaShade[®] Sunshade System for Curtain Wall Concealed Anchor

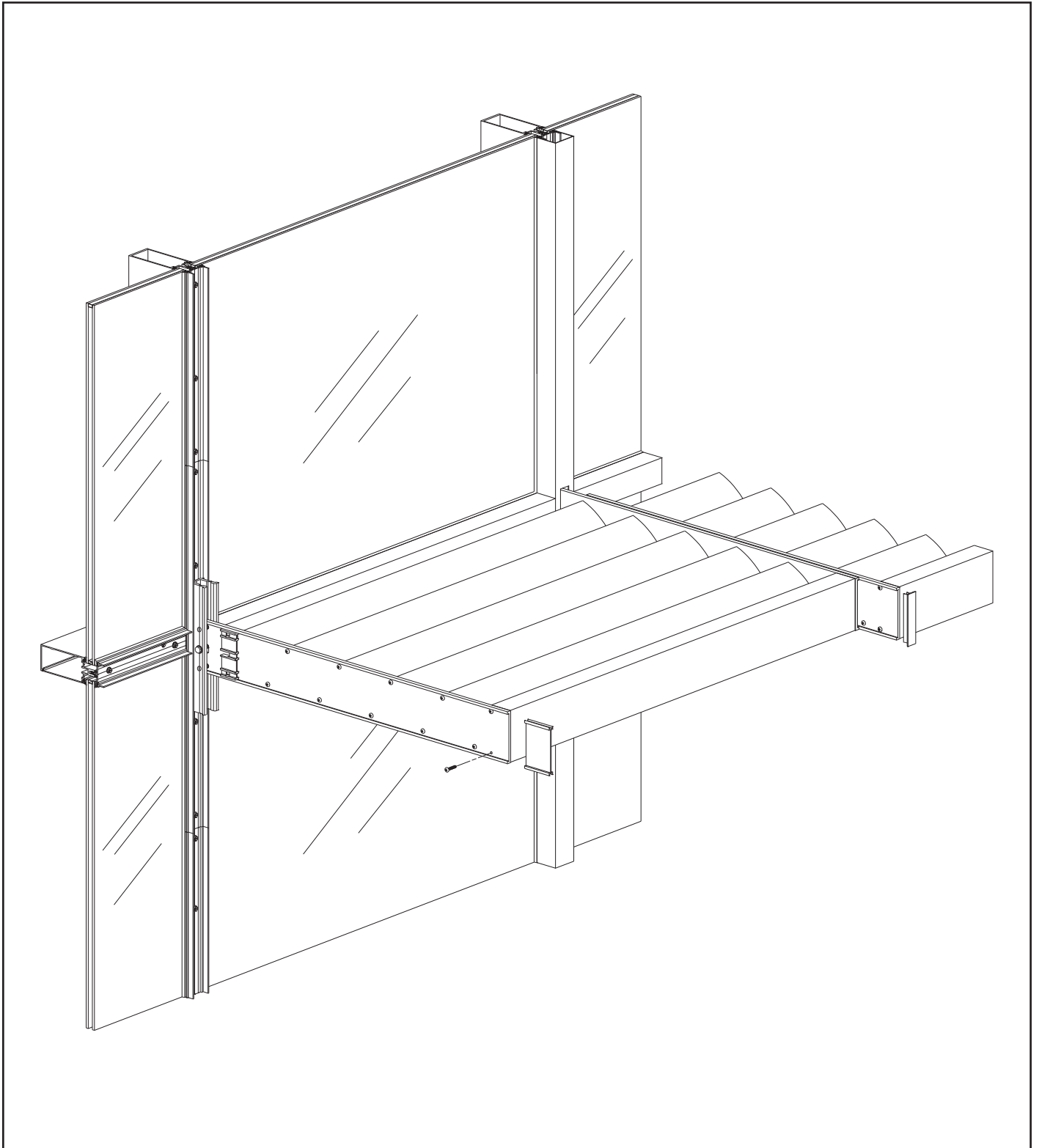

Installation Manual



Prior to fabrication and installation of the YKK AP ThermaShade™ system, an engineering review **MUST** be completed. A qualified engineer must review the “combined load” information for the project to ensure proper selection of curtain wall and ThermaShade members.

Please maintain an executed copy of the document in your project file.

A blank copy of the document is contained in the ThermaShade price book and design manual section.

TABLE OF CONTENTS

Installation Notes	Page ii
PARTS DESCRIPTION	
ThermaShade Stock Lengths	Page 1
ThermaShade Outriggers	Pages 2 to 7
ThermaShade Accessories	Pages 8 & 9
ASSEMBLY FABRICATION	
ThermaShade Assembly Fabrication	Pages 10 to 12
Mullion Preparation (YCW 750 XT only)	Page 13
Pressure Plate Fabrication	Pages 14 & 15
Pressure Plate Layout	Page 16
STANDARD ASSEMBLY INSTALLATION	
Anchor Clip Attachment.....	Pages 17 to 19
Install ThermaShade Assemblies	Pages 19 to 22
Install Face Covers.....	Pages 23 & 24
ANCHOR CLIP, OUTRIGGER, COVER, CORNER ASSEMBLY	
Anchor Clip Attachment.....	Page 24
Install ThermaShade Assemblies	Page 25
Install Face Covers & Outrigger End Cap	Page 26
Anchor Clip Attachment.....	Page 27
Install ThermaShade Assemblies & Outrigger	Pages 28 to 30
Install Mitered Cover.....	Page 31
YHC 300 Anchor Clip Preparation.....	Page 32
WALL MOUNT ATTACHMENT	
Combined Load Charts.....	Page 32
Anchor Clip Attachment.....	Pages 34 & 35
Attach Louvers and Fascia	Page 36
Install Outriggers	Page 36
Install Face Covers.....	Pages 36 & 37
REGLAZING INSTRUCTIONS	
Reglazing Curtain Wall	Page 38

Note: All illustrations show examples of YCW 750. ThermaShade can be used also on YHC 300. Details may vary but are called out and illustrated where required.

Installation Notes

1. Do not drop, roll or drag boxes of aluminum framing. Move and stack boxes with proper support to prevent distortion. If fork lifts are used, be especially careful about striking the boxes when lifting or moving.
2. Store in a dry, out of the way area. If rain exposure, condensation or any water contact is likely, then all packaging material should be removed. Wet packaging materials will discolor and may stain aluminum finishes and paints.
3. All materials should be checked for quality and quantity upon receipt, YKK AP must be notified immediately of any discrepancies in shipment. Check to make sure that you have the required shims, sealants, supplies and tools necessary for the installation.
4. Carefully check the openings and surrounding conditions that will receive your material. Remember, if the construction is not per the construction documents, it is your responsibility to notify the general contractor in writing. Any discrepancies must be brought to the general contractor's attention before you proceed with the installation.
5. Gather your shop drawings, materials, packing list, and this installation manual. Carefully review parts, location, the sequence it goes therein, when you glaze it and how you seal it. Installation instructions are of a general nature and may not cover every condition you will encounter. The shop drawings and/or installation manuals were prepared specifically for the product.
6. Any material substitutions must be of equal or greater quality.
7. Make certain that material samples have been sent for compatibility testing for all manufacturer's sealants involved. Make certain sealants have been installed in strict accordance with the manufacturer's recommendations and specifications, including cleaning and priming all parts.
8. Remember to isolate, in an approved manner, all aluminum from uncured masonry or other incompatible materials.
9. System-to-structure fasteners are not supplied by YKK AP. Fasteners called out on shop drawings are to indicate minimum sizes for design loading.
10. If any questions arise concerning YKK AP products or their installation, contact YKK AP for clarification before proceeding.
11. YKK AP storefront and/or curtain wall framing is typically completed before drywall, flooring and other products which may still be in process. Take the extra time to wrap and protect the work produced.
12. Cutting tolerances are plus zero, minus one thirty second unless otherwise noted.
13. Check our website, www.ykkap.com, for the latest installation manual update prior to commencing work.

STOCK LENGTHS

 <p>3-1/2" Round Louver or Fascia</p>	E9-3705	 <p>3-5/8" Airfoil Louver Only</p>	E9-3713
 <p>3" Round Louver or Fascia</p>	E9-3706	 <p>Square 3-1/2" x 3-1/2" Louver or Fascia</p>	E9-3714
 <p>3" Winged Louver Only</p>	E9-3707	 <p>Rectangular 2-1/4" x 5" Fascia Only</p>	E9-3715
 <p>6" Open Airfoil Louver Only</p>	E9-3708	 <p>Pressure Plate For Deep Covers With PVC Isolator For 1/4" & 1" Glazing</p>	AS-3574
 <p>6" Airfoil Louver Only</p>	E9-3709	 <p>Face Cover 2-1/2" x 2-1/4"</p>	E9-3704
 <p>Angle 5-3/4" x 4-1/4" Louver Only</p>	E9-3710	 <p>Face Cover 3" x 2-1/4"</p>	E9-3720
 <p>Wedge 6" x 1-3/4" Fascia Only</p>	E9-3711	 <p>Face Cover 3" x 2-1/8"</p>	E9-3723
 <p>2-1/4" Round Louver Only</p>	E9-3712	 <p>Jamb Adapter YCW 750 90° Outside Corner</p>	E9-3717



STANDARD OUTRIGGERS

Example:
E1-3820L-0200 (Left)
E1-3820R-0200 (Right)

	Square End Bay Outrigger Use for End Bay Condition Only	24" E1-3820L or R-0200 30" E1-3820L or R-0206 36" E1-3820L or R-0300
	Square Intermediate Outrigger Use with E9-3705 & E9-3714	24" E1-3821L or R-0200 30" E1-3821L or R-0206 36" E1-3821L or R-0300
	Square Intermediate Outrigger Use with E9-3705, E9-3706, E9-3707 & E9-3714	24" E1-3822L or R-0200 30" E1-3822L or R-0206 36" E1-3822L or R-0300
	Square Intermediate Outrigger Use with E9-3705, E9-3708, E9-3709, E9-3710 & E9-3714	24" E1-3823L or R-0200 30" E1-3823L or R-0206 36" E1-3823L or R-0300
	Square Intermediate Outrigger Use with E9-3705, E9-3714 & E9-3715	24" E1-3824L or R-0200 30" E1-3824L or R-0206 36" E1-3824L or R-0300
	Square Intermediate Outrigger Use with E9-3706, E9-3707 & E9-3715	24" E1-3825L or R-0200 30" E1-3825L or R-0206 36" E1-3825L or R-0300
	Square Intermediate Outrigger Use with E9-3708, E9-3709, E9-3710 & E9-3715	24" E1-3826L or R-0200 30" E1-3826L or R-0206 36" E1-3826L or R-0300
	Rounded End Bay Outrigger Use for End Bay Condition Only	24" E1-3840L or R-0200 30" E1-3840L or R-0206 36" E1-3840L or R-0300
	Rounded Intermediate Outrigger Use with E9-3705 & E9-3714	24" E1-3841L or R-0200 30" E1-3841L or R-0206 36" E1-3841L or R-0300
	Rounded Intermediate Outrigger Use with E9-3705, E9-3706 & E9-3707	24" E1-3842L or R-0200 30" E1-3842L or R-0206 36" E1-3842L or R-0300
	Rounded Intermediate Outrigger Use with E9-3705, E9-3708, E9-3709 & E9-3710	24" E1-3843L or R-0200 30" E1-3843L or R-0206 36" E1-3843L or R-0300
	Rounded Intermediate Outrigger Use with E9-3706 & E9-3707	24" E1-3844L or R-0200 30" E1-3844L or R-0206 36" E1-3844L or R-0300

STANDARD OUTRIGGERS

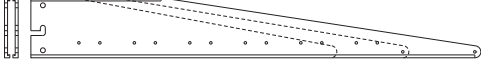
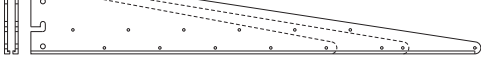
Example:
E1-3860L-0200 (Left)
E1-3860R-0200 (Right)

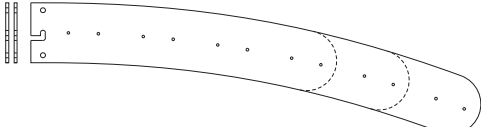
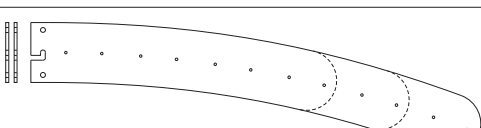
	<p>Wedge End Bay Outrigger Use for End Bay Condition Only</p>	<p>24" E1-3860L or R-0200 30" E1-3860L or R-0206 36" E1-3860L or R-0300</p>
	<p>Wedge Intermediate Outrigger Use with E9-3711 & E9-3712</p>	<p>24" E1-3861L or R-0200 30" E1-3861L or R-0206 36" E1-3861L or R-0300</p>
	<p>Wedge Intermediate Outrigger Use with E9-3711 & E9-3713</p>	<p>24" E1-3862L or R-0200 30" E1-3862L or R-0206 36" E1-3862L or R-0300</p>
	<p>Curved End Bay Outrigger Use for End Bay Condition Only</p>	<p>24" E1-3880L or R-0200 30" E1-3880L or R-0206 36" E1-3880L or R-0300</p>
	<p>Curved Intermediate Outrigger Use with E9-3705, E9-3708 & E9-3709</p>	<p>24" E1-3881L or R-0200 30" E1-3881L or R-0206 36" E1-3881L or R-0300</p>
	<p>Curved Intermediate Outrigger Use with E9-3705</p>	<p>24" E1-3882L or R-0200 30" E1-3882L or R-0206 36" E1-3882L or R-0300</p>
	<p>Curved Intermediate Outrigger Use with E9-3706 & E9-3707</p>	<p>24" E1-3883L or R-0200 30" E1-3883L or R-0206 36" E1-3883L or R-0300</p>

Actual lengths are 1-1/2" longer than nominal.

90° OUTSIDE CORNER OUTRIGGERS

Example:
E1-3820L-A200 (Left)
E1-3820R-A200 (Right)

	Square End Bay Outrigger Use for End Bay Condition Only	24" E1-3820L or R-A200 30" E1-3820L or R-A206 36" E1-3820L or R-A300
	Square Intermediate Outrigger Use with E9-3705 & E9-3714	24" E1-3821L or R-A200 30" E1-3821L or R-A206 36" E1-3821L or R-A300
	Square Intermediate Outrigger Use with E9-3705, E9-3706, E9-3707 & E9-3714	24" E1-3822L or R-A200 30" E1-3822L or R-A206 36" E1-3822L or R-A300
	Square Intermediate Outrigger Use with E9-3705, E9-3708, E9-3709, E9-3710 & E9-3714	24" E1-3823L or R-A200 30" E1-3823L or R-A206 36" E1-3823L or R-A300
	Square Intermediate Outrigger Use with E9-3705, E9-3714 & E9-3715	24" E1-3824L or R-A200 30" E1-3824L or R-A206 36" E1-3824L or R-A300
	Square Intermediate Outrigger Use with E9-3706, E9-3707 & E9-3715	24" E1-3825L or R-A200 30" E1-3825L or R-A206 36" E1-3825L or R-A300
	Square Intermediate Outrigger Use with E9-3708, E9-3709, E9-3710 & E9-3715	24" E1-3826L or R-A200 30" E1-3826L or R-A206 36" E1-3826L or R-A300
	Rounded End Bay Outrigger Use for End Bay Condition Only	24" E1-3840L or R-A200 30" E1-3840L or R-A206 36" E1-3840L or R-A300
	Rounded Intermediate Outrigger Use with E9-3705 & E9-3714	24" E1-3841L or R-A200 30" E1-3841L or R-A206 36" E1-3841L or R-A300
	Rounded Intermediate Outrigger Use with E9-3705, E9-3706 & E9-3707	24" E1-3842L or R-A200 30" E1-3842L or R-A206 36" E1-3842L or R-A300
	Rounded Intermediate Outrigger Use with E9-3705, E9-3708, E9-3709 & E9-3710	24" E1-3843L or R-A200 30" E1-3843L or R-A206 36" E1-3843L or R-A300
	Rounded Intermediate Outrigger Use with E9-3706 & E9-3707	24" E1-3844L or R-A200 30" E1-3844L or R-A206 36" E1-3844L or R-A300

90° OUTSIDE CORNER OUTRIGGERS

Example:
E1-3860L-A200 (Left)
E1-3860R-A200 (Right)

	<p>Wedge End Bay Outrigger Use for End Bay Condition Only</p>	<p>24" E1-3860L or R-A200 30" E1-3860L or R-A206 36" E1-3860L or R-A300</p>
	<p>Wedge Intermediate Outrigger Use with E9-3711 & E9-3712</p>	<p>24" E1-3861L or R-A200 30" E1-3861L or R-A206 36" E1-3861L or R-A300</p>
	<p>Wedge Intermediate Outrigger Use with E9-3711 & E9-3713</p>	<p>24" E1-3862L or R-A200 30" E1-3862L or R-A206 36" E1-3862L or R-A300</p>
	<p>Curved End Bay Outrigger Use for End Bay Condition Only</p>	<p>24" E1-3880L or R-A200 30" E1-3880L or R-A206 36" E1-3880L or R-A300</p>
	<p>Curved Intermediate Outrigger Use with E9-3705, E9-3708 & E9-3709</p>	<p>24" E1-3881L or R-A200 30" E1-3881L or R-A206 36" E1-3881L or R-A300</p>
	<p>Curved Intermediate Outrigger Use with E9-3705</p>	<p>24" E1-3882L or R-A200 30" E1-3882L or R-A206 36" E1-3882L or R-A300</p>
	<p>Curved Intermediate Outrigger Use with E9-3706 & E9-3707</p>	<p>24" E1-3883L or R-A200 30" E1-3883L or R-A206 36" E1-3883L or R-A300</p>

Actual lengths are longer than nominal due to the geometry of a 90° corner.

90° INSIDE CORNER OUTRIGGERS

Example:

E1-3820L-B200 (Left)

E1-3820R-B200 (Right)

	<p>Square End Bay Outrigger Use for End Bay Condition Only</p>	<p>24" E1-3820L or R-B200 30" E1-3820L or R-B206 36" E1-3820L or R-B300</p>
	<p>Square Intermediate Outrigger Use with E9-3705 & E9-3714</p>	<p>24" E1-3821L or R-B200 30" E1-3821L or R-B206 36" E1-3821L or R-B300</p>
	<p>Square Intermediate Outrigger Use with E9-3705, E9-3706, E9-3707 & E9-3714</p>	<p>24" E1-3822L or R-B200 30" E1-3822L or R-B206 36" E1-3822L or R-B300</p>
	<p>Square Intermediate Outrigger Use with E9-3705, E9-3708, E9-3709, E9-3710 & E9-3714</p>	<p>24" E1-3823L or R-B200 30" E1-3823L or R-B206 36" E1-3823L or R-B300</p>
	<p>Square Intermediate Outrigger Use with E9-3705, E9-3714 & E9-3715</p>	<p>24" E1-3824L or R-B200 30" E1-3824L or R-B206 36" E1-3824L or R-B300</p>
	<p>Square Intermediate Outrigger Use with E9-3706, E9-3707 & E9-3715</p>	<p>24" E1-3825L or R-B200 30" E1-3825L or R-B206 36" E1-3825L or R-B300</p>
	<p>Square Intermediate Outrigger Use with E9-3708, E9-3709, E9-3710 & E9-3715</p>	<p>24" E1-3826L or R-B200 30" E1-3826L or R-B206 36" E1-3826L or R-B300</p>
	<p>Rounded End Bay Outrigger Use for End Bay Condition Only</p>	<p>24" E1-3840L or R-B200 30" E1-3840L or R-B206 36" E1-3840L or R-B300</p>
	<p>Rounded Intermediate Outrigger Use with E9-3705 & E9-3714</p>	<p>24" E1-3841L or R-B200 30" E1-3841L or R-B206 36" E1-3841L or R-B300</p>
	<p>Rounded Intermediate Outrigger Use with E9-3705, E9-3706 & E9-3707</p>	<p>24" E1-3842L or R-B200 30" E1-3842L or R-B206 36" E1-3842L or R-B300</p>
	<p>Rounded Intermediate Outrigger Use with E9-3705, E9-3708, E9-3709 & E9-3710</p>	<p>24" E1-3843L or R-B200 30" E1-3843L or R-B206 36" E1-3843L or R-B300</p>
	<p>Rounded Intermediate Outrigger Use with E9-3706 & E9-3707</p>	<p>24" E1-3844L or R-B200 30" E1-3844L or R-B206 36" E1-3844L or R-B300</p>





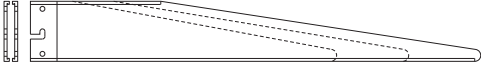
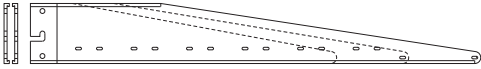
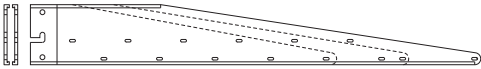
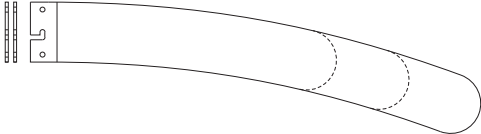
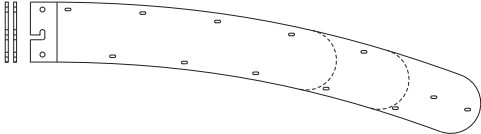
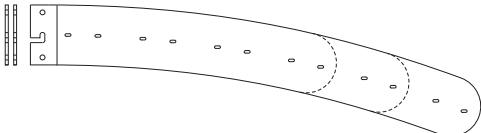
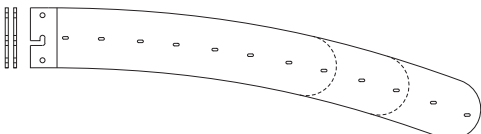

90° INSIDE CORNER OUTRIGGERS

Example:
E1-3860L-B200 (Left)
E1-3860R-B200 (Right)

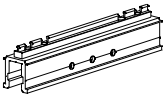



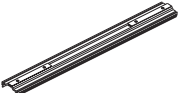
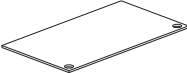



	<p>Wedge End Bay Outrigger Use for End Bay Condition Only</p>	<p>24" E1-3860L or R-B200 30" E1-3860L or R-B206 36" E1-3860L or R-B300</p>
	<p>Wedge Intermediate Outrigger Use with E9-3711 & E9-3712</p>	<p>24" E1-3861L or R-B200 30" E1-3861L or R-B206 36" E1-3861L or R-B300</p>
	<p>Wedge Intermediate Outrigger Use with E9-3711 & E9-3713</p>	<p>24" E1-3862L or R-B200 30" E1-3862L or R-B206 36" E1-3862L or R-B300</p>
	<p>Curved End Bay Outrigger Use for End Bay Condition Only</p>	<p>24" E1-3880L or R-B200 30" E1-3880L or R-B206 36" E1-3880L or R-B300</p>
	<p>Curved Intermediate Outrigger Use with E9-3705, E9-3708 & E9-3709</p>	<p>24" E1-3881L or R-B200 30" E1-3881L or R-B206 36" E1-3881L or R-B300</p>
	<p>Curved Intermediate Outrigger Use with E9-3705</p>	<p>24" E1-3882L or R-B200 30" E1-3882L or R-B206 36" E1-3882L or R-B300</p>
	<p>Curved Intermediate Outrigger Use with E9-3706 & E9-3707</p>	<p>24" E1-3883L or R-B200 30" E1-3883L or R-B206 36" E1-3883L or R-B300</p>

Actual lengths are longer than nominal due to the geometry of a 90° corner.

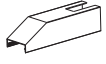
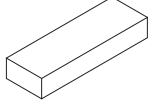
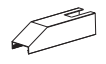

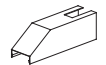

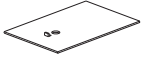

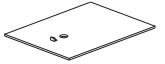

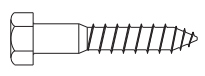

ACCESSORIES

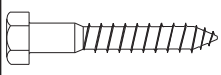
	Anchor Clip	E1-3801		90° Outside Corner Steel Anchor Use with E9-3101 (Insulating)	E1-3818
	Anchor Clip Use with YHC 300 OG Insulating	E1-3828		90° Outside Corner Steel Anchor Use with E9-3103 (Monolithic)	E1-3819
	Anchor Clip Use with YHC 300 OG Monolithic	E1-3829		Outrigger Spacer	E1-3803
	Notched 36\" Pressure Plate Use with E9-3704	E1-3802		Outrigger Connector	E1-3804
	Notched 36\" Pressure Plate Use with E9-1206	E1-3834		Square Outrigger End Cap	E1-3805
	Notched 36\" Pressure Plate Use with YHC 300 OG Insulating	E1-3866		Wall Mount Anchor Clip	E1-3830
	Notched 36\" Pressure Plate Use with YHC 300 OG Monolithic	E1-3867		Wall Mount Face Cover	E1-3831
	Notched 36\" Pressure Plate Use with YCW 750 XT	E1-3864		Wall Mount End Cap 2-1/4" x 4" x 0.050"	E1-3832
	Notched 36\" Jamb Pressure Plate Use with YHC 300 OG Insulating	E1-3868		Face Cover Splice	E1-3806
	Notched 36\" Jamb Pressure Plate Use with YHC 300 OG Monolithic	E1-3869		Medallion 3-1/2" Dia. Use with E1-3808	E1-3807
	Notched 36\" Jamb Pressure Plate Use with YCW 750 XT	E1-3865		Medallion Spacer w/ Slot 3-1/2" Dia.	E1-3808
	90° Outside Corner Steel Anchor Use with E9-1215 & E9-1225	E1-3817		Medallion 1" Dia. Use with E1-3810	E1-3809

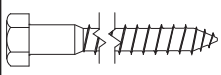
ACCESSORIES

	Medallion Spacer 1" Dia. Use with E1-3809	E1-3810		Mullion End Cap 3" x 3-1/2" x 0.050"	E1-3023
	Mitered Face Cover Use with YCW 750	E1-3833		Outrigger Plug 1-1/2" x 4-1/2" x 0.75" @ 90° Corners	E2-3801
	Mitered Face Cover Use with YHC 300	E1-3839		18" Long PVC Filler Use with YCW 750 XT	E3-3703
	Mitered Face Cover Use with YCW 750 XT	E1-3863		Splice Sleeve for Face Cover Use with E1-3833 & E1-3863	E1-1202
	Mullion End Cap 2-1/2" x 3-13/16" x 0.050"	E1-1276		Splice Sleeve for Face Cover Use with E1-3839	E1-3009
	Mullion End Cap 3" x 4" x 0.050"	E1-3022			

FASTENERS

	3/8" x 2" Lag Screw Stainless Steel, For Attach. of Anchor Clip to Mullion Four per Anchor Clip	HW-3832 -SS		3/8" Flat Washer , Stainless Steel For Attachment of Outrigger to Anchor Clip	WW-3800 -SS
	3/8" x 2-1/2" Lag Screw Stainless Steel, For Attach. of Anchor Clip to Mullion Four per Anchor Clip	HW-3840 -SS		3/8" Lock Washer , Stainless Steel, For Attachment of Outrigger to Anchor Clip	WS-3800 -SS
	3/8" x 3" Lag Screw Stainless Steel, For Attach. of Anchor Clip to Mullion Four per Anchor Clip	HW-3848 -SS		#10 x 1" PHSMS Type AB Stainless Steel, For Attachment of Louvers/ Fascia to Outrigger	PC-1016 -SS
	3/8" x 2" Bolt , Stainless Steel, For Attachment of Outrigger to Anchor Clip Three per Anchor Clip	HM-3832 -SS		#10 x 1-3/4" FHSMS Type AB Stainless Steel, For Attachment of Louvers to Corner Outrigger	FC-1028 -SS
	3/8" Jamb Nut , Stainless Steel, For Attachment of Outrigger to Anchor Clip	JM-3800 -SS		#8 x 1/2" FHSMS Type AB Stainless Steel, For Attachment of 2-1/4" Face Cover to Anchor Clip	FC-0808 -SS
	1/4"-20 x 1-3/4" HWHS Type F , Zinc Plated Steel	HF-2528 -W1			

THERMASHADE ASSEMBLY FABRICATION

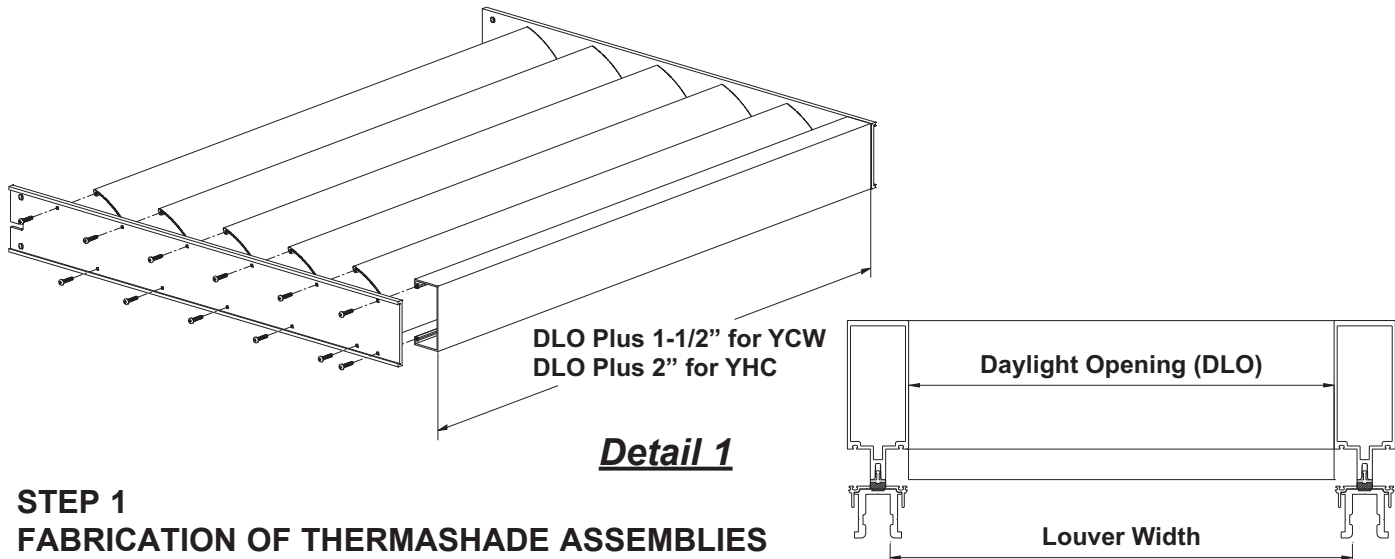

STEP 1 FABRICATION OF THERMASHADE ASSEMBLIES

For proper anchoring of the outrigger: The top of the outrigger must be a minimum of 4-1/2" down from the top of the curtain wall.

Intermediate Outriggers

-Cut louvers and optional fascia to DLO plus 1-1/2" for YCW 750, and 2" for YHC 300. Accurate sizing is critical for a quality installation. Field measure as needed. To field measure after the anchor clips are installed, lay the measuring tape from the inside right leg of the anchor clip to the inside left leg of the adjacent anchor clip (this is the proper louver width).

See **Detail 1**.

-Prepare ThermaShade assemblies by fastening two (2) outriggers to the cut louvers and fascia.

Note: Some outriggers are produced from aluminum plate and are not handed. Other outriggers are produced from extruded aluminum and are handed.

See **Detail 2A** for proper alignment of extruded outriggers.

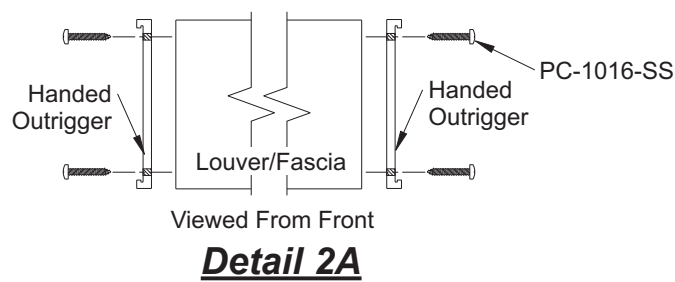

THERMASHADE ASSEMBLY FABRICATION

Corner Outriggers

-Louvers and fascia are to be cut 45° for inside and outside outrigger assemblies. All louvers and fascia must be flat on the cutting table with splines at the same location as the standard outrigger hole location shown on the approved shop drawings. Lengths must be calculated or determined from shop drawing layout.

-Prepare ThermaShade assemblies by fastening two (2) outriggers to the cut louvers and fascia.

Note: Some outriggers are produced from aluminum plate and are not handed. Other outriggers are produced from extruded aluminum and are handed.

See **Detail 2B** for proper alignment of extruded outriggers.

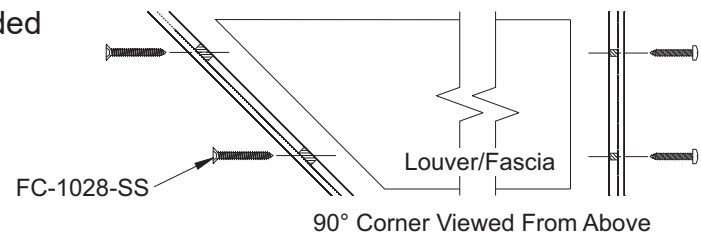

Detail 2B

STEP 2

Intermediate Outriggers

- Attach louver to the outrigger with PC-1016-SS screws by aligning pre-drilled holes in the outrigger with the screw splines of the louver.
- Ensure that the notch at the center of the outrigger points upward to prevent attaching the outriggers upside down. Do not tighten screws completely until all louvers and fascia are attached, then tighten all fasteners until the connections are snug.

See **Detail 3A**.

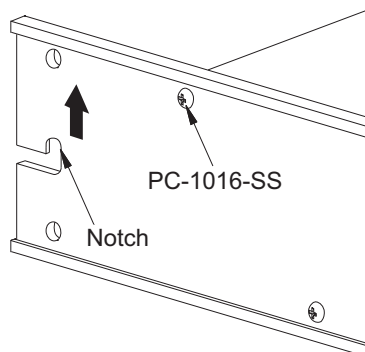

Detail 3A

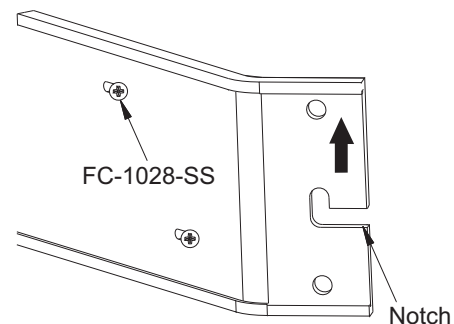

Detail 3B

THERMASHADE ASSEMBLY FABRICATION

Corner Outriggers

-Louvers and fascia are installed to the outriggers in a similar fashion as the standard assembly. The corner outrigger is attached with a longer, flat head screw FC-1028-SS. This screw is attached thru a special sized slotted hole, and will seat into the end of the slot with a portion of the flat heads screw not completely countersunk.

See **Detail 3B**.

- As the louvers and fascia are installed onto the outrigger, wax the screw threads and tighten into screw spline of the louver 1/2" short of completely tightening. After all of the screws are located and semi-tightened, start at the large end and work the screws into the splines as needed. Tighten until well seated, without over torquing.

See **Detail 3C**.

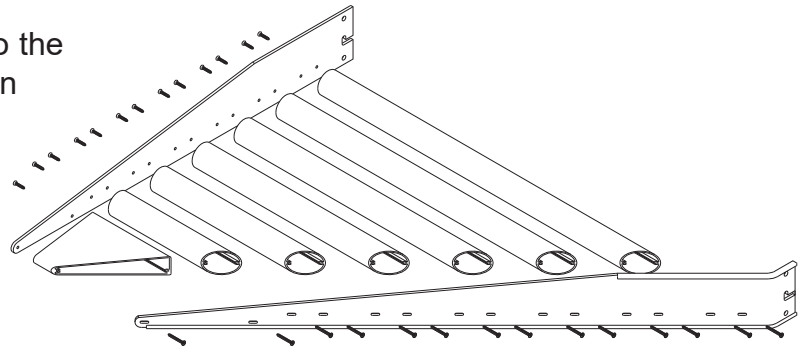

Detail 3C

Inside Corner Shown,
Outside Corner Similar

THERMASHADE ASSEMBLY FABRICATION

STEP 3 MULLION PREPARATION (YCW 750 XT ONLY)

Installing Thermashade in YCW 750 XT curtain wall requires a PVC filler E3-3703 to be inserted into the mullion at the outrigger to reinforce the thermal break in the mullion.

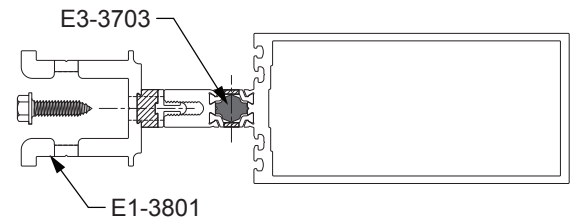

Note: This step should be performed prior to field erection of the YCW 750 XT curtain wall.

Detail 4

- Drill 1/4" clear holes on each side of the thermal break at the outrigger anchor center line.
- Mark the 18" long PVC filler E3-3703 at its midpoint. Slide the filler into the void between until the center mark is visible in the clear holes.
- Seal the filler in place through the clear holes, tool smooth, and allow it to cure over night.
- Attach the E1-3801 anchor clip to the mullion, where centered at the outrigger location with one (1) pressure plate screw per specific curtain wall installation instructions. This anchor clip will be used as a drill fixture.
- Drill 0.316" dia. ("O" bit) pilot holes. Drill the pilot hole into the center of the slotted hole screw location.

Installation Tip: Due to the tendency for drill bits to bind when inserted into the tongue of the vertical mullion, run the drill at full speed and then slowly drill into the mullion tongue. It is essential that the pilot holes are drilled true, level and clean to ensure proper anchoring of the system.

See **Detail 4**.

Caution: Do not oversize anchor holes while drilling.

Remove the anchor clip from the mullion until field installation.

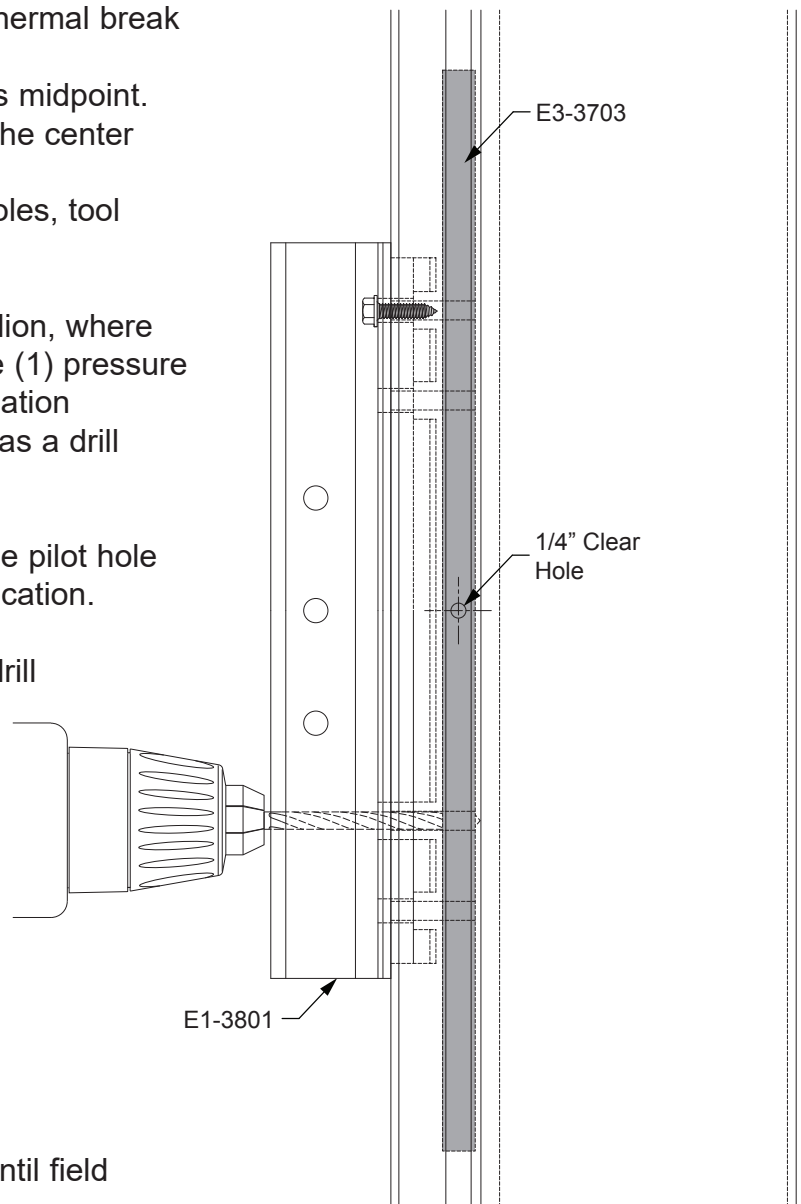

PRESSURE PLATE FABRICATION**STEP 4****PRESSURE PLATE FABRICATION**

In order to attach ThermaShade assemblies to the curtain wall, the pressure plate must be notched at the location of each anchor clip. This notching can be accomplished in three ways:

1. Purchase the fabricated part. See **Detail 5A**.
2. Shop fabricate a comparable 36" part. See **Detail 5A**.
3. Shop fabricate the notch in the appropriate location in a full length of pressure plate .

See **Detail 5B**.

Shop Fabrication

- Prior to attachment, the pressure plates must be notched to accept the ThermaShade anchoring system.
 - Notch the pressure plate 12" long by 3/4" wide, centered in the pressure plate. Within this gap the thermal isolator must also be removed.
 - Drill additional 0.281" fastener clear holes if required to ensure that holes are within 1-1/2" of the notch.
 - Attach pressure plate to curtain wall system by centering the notch at the center of the 5" outrigger and torque the HD-2516-W3 bolts per the curtain wall installation instructions.
- See **Detail 5B**.

PRESSURE PLATE FABRICATION

YCW 750 OG Shown, YCW 750 XT and YHC 300 Similar

STEP 4 (cont'd)

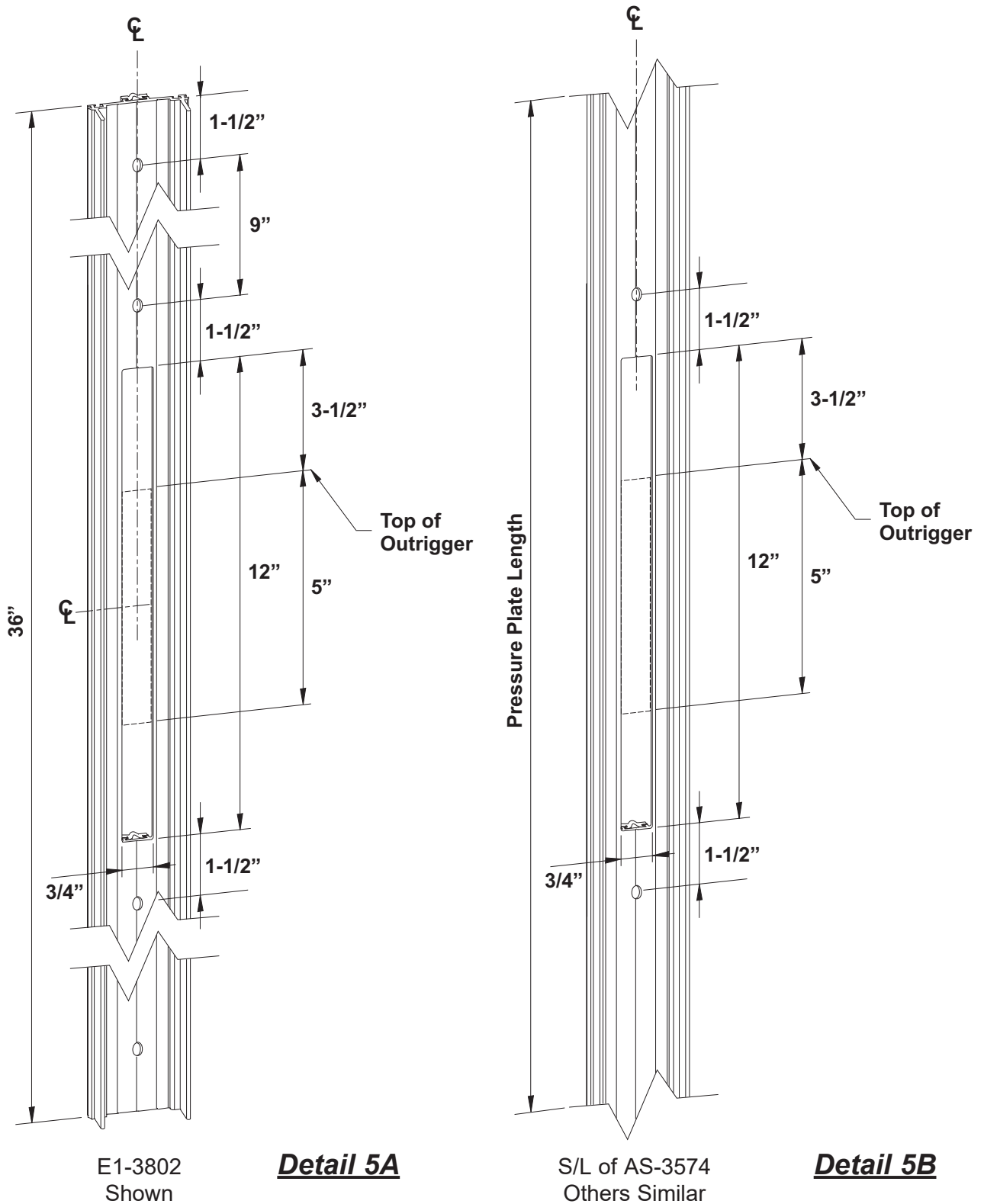

PRESSURE PLATE LAYOUT

STEP 4 (cont'd)

* YHC 300 Note: Refer to page 30 for E9-3101

Fabricated Pressure Plate E1-3802:

- Remove temporary glass retainers in the sunshade area two feet above and below the location of the outrigger.
- Add appropriate gaskets on both sides of the E1-3802 pressure plate.
- Install the E1-3802 fabricated pressure plate into the temporary glazed curtain wall by positioning the top of the notch 3-1/2" above the top edge of where the outrigger is located.
- Install surrounding pressure plates to the vertical mullion. Leave a 1/4" expansion joint between vertical pressure plate splices and fill the joint with sealant, tool sealant for a water tight joint.

See **Detail 6**.

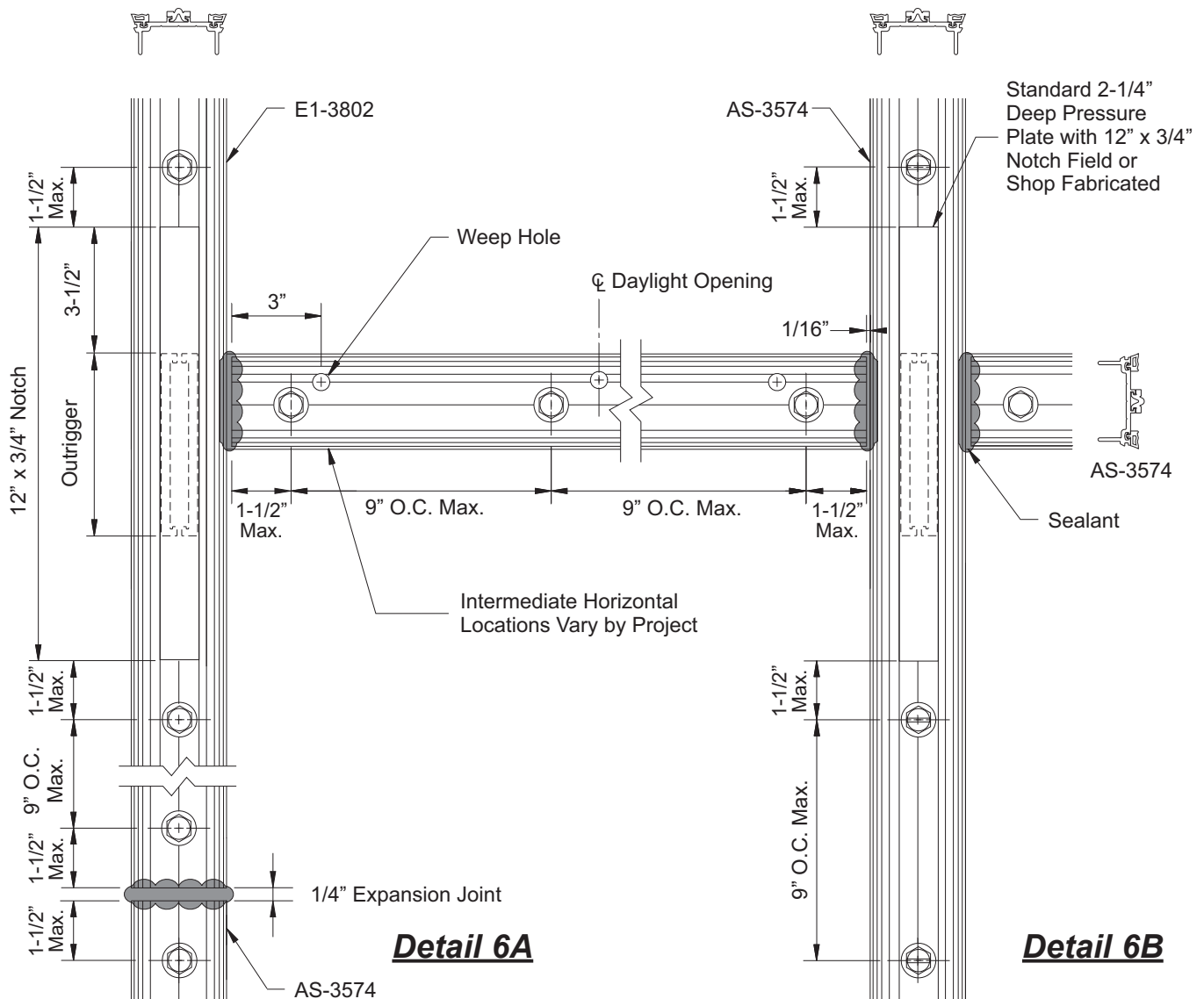

ANCHOR CLIP ATTACHMENT

STEP 5

ATTACH ANCHOR CLIP

-Position and seat anchor clip into the mullion tongue of the curtain wall. Pre-attach the mullion clip with one (1) pressure plate screw per specific curtain wall installation instructions.

Installation Tip: To ensure proper alignment of the ThermaShade system, snap on a small scrap piece of face cover onto the closest horizontal and verify the reference dimension from shop drawings.

See **Detail 7**.

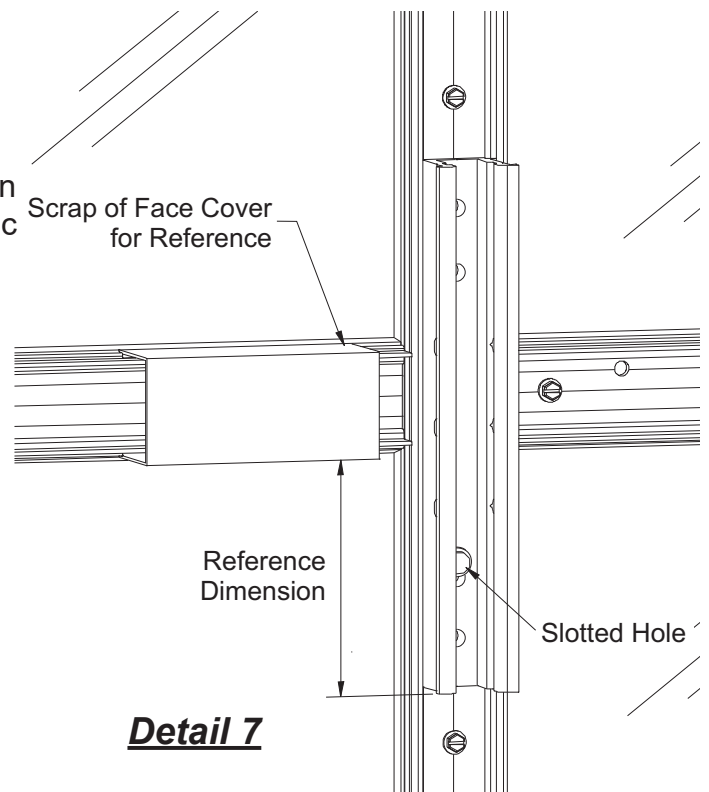

-Drill 0.316" dia. ("O" bit) pilot holes. Drill the pilot hole into the center of the slotted hole screw location.

Installation Tip: Due to the tendency for drill bits to bind when inserted into the tongue of the vertical mullion, run the drill at full speed and then slowly drill into the mullion tongue. It is essential that the pilot holes are drilled true, level and clean to ensure proper anchoring of the system.

See **Detail 8**.

Caution: Do not oversize anchor holes while drilling.

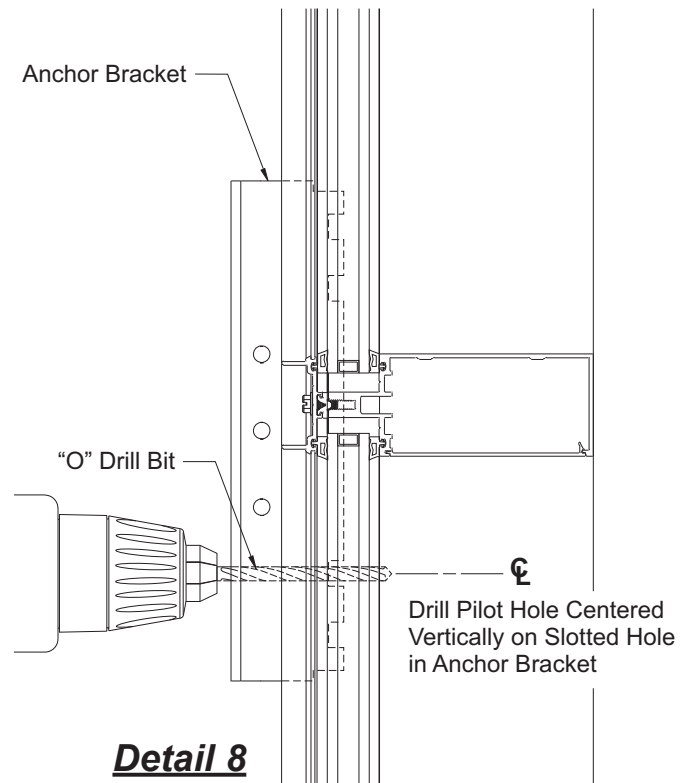

ANCHOR CLIP ATTACHMENT

STEP 5 (Cont'd)

-Once the first pilot hole is drilled, remove the anchor clip from the curtain wall and apply sealant the perimeter of the pressure plate notch.

See **Detail 9**.

-Reinsert anchor into notch. Seal the slotted pilot hole and install the first WW-3800-SS washer and appropriate lag screw as shown on **Detail 9A** (Do Not Substitute).

NOTE: Due to the use of stainless steel lag screws, a hand ratchet **MUST** be used to prevent the screw heads from breaking off due to over straining, a result which could occur from the use of a power drill. Do not remove and re-install lag screws as over-sizing the holes may occur.

System	Lag Screw
YCW 750 OG, YHC 300 OG monolithic	HW-3832-SS
YHC 300 OG insulating	HW-3840-SS
YCW 750 XT	HW-3848-SS

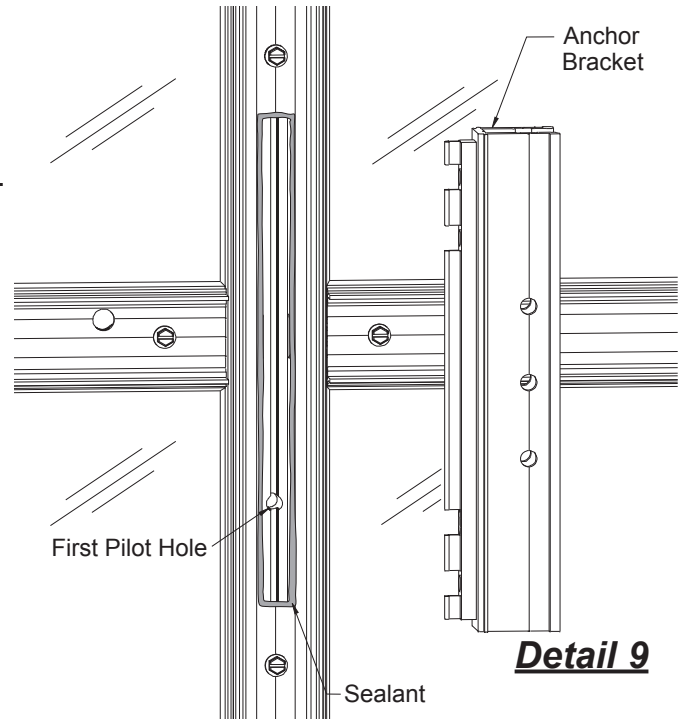

Detail 9A

- Before completely tightening the first lag screw, adjust the anchor clip up or down in the slotted hole as needed until the clip is in the exact location required. After thoroughly checking the vertical alignment, snug the lag screw until the anchor clip meets the mullion.
- Drill remainder of pilot holes in identical fashion as first one, minus removing anchor clip following each drill.
- Seal and install the washers and lag screws into the remaining hole locations, beginning with the top screw and working down. Tighten the screws until the screw head, washers and the extrusion fit together snugly. **DO NOT** over-tighten.

NOTE: Do not allow sealant to adhere to the center 6" of the inside wall of the anchor clip.

See **Detail 10**.

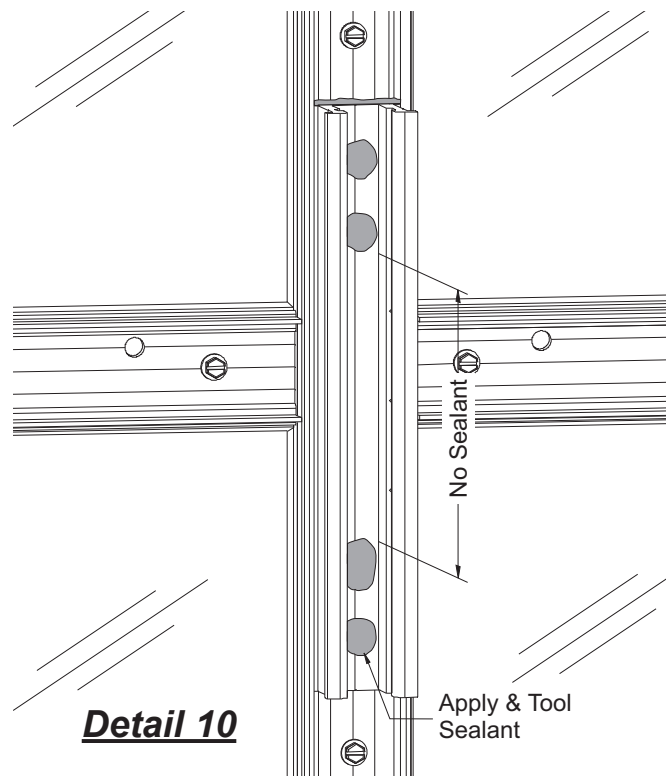

INSTALL THERMASHADE ASSEMBLIES

STEP 5 (Cont'd)

-Once the anchors are installed, insert the middle 2" x 3/8" thru bolt HM-3832-SS and WW-3800-SS flat washer into anchor and hand tighten with the WS-3800-SS lock washer and JM-3800-SS jamb nut. This center bolt will be used to temporarily hang the ThermaShade assemblies during the installation process.

See **Detail 11**.

STEP 6 INSTALLING OUTRIGGER ASSEMBLIES

Note: If corner conditions are present, it is recommended that the corner assemblies are installed prior to the intermediate outriggers.

-Stack or lay outrigger assemblies as they will be installed. Spacers (E1-3803) can be pre-attached to ONE* side of the outrigger assembly by sliding the spacer into the outrigger's track a few inches beyond the thru bolt holes in the outrigger. The spacer can then be kept from falling out by compressing the end of the outrigger slightly with vise grips or a hammer.

***Note:** The first assembly in the array requires installation of the E1-3803 spacer on both outriggers.

See **Detail 12**. If the spacers are not installed prior to installing the ThermaShade assemblies, the spacers may be installed as the units go up. The following procedure will assume they are pre-attached.

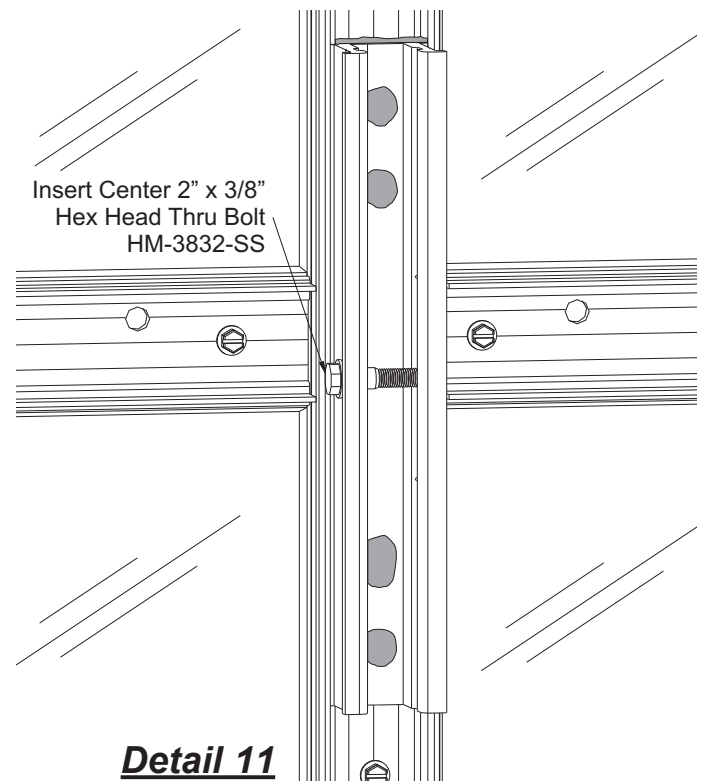

Detail 11

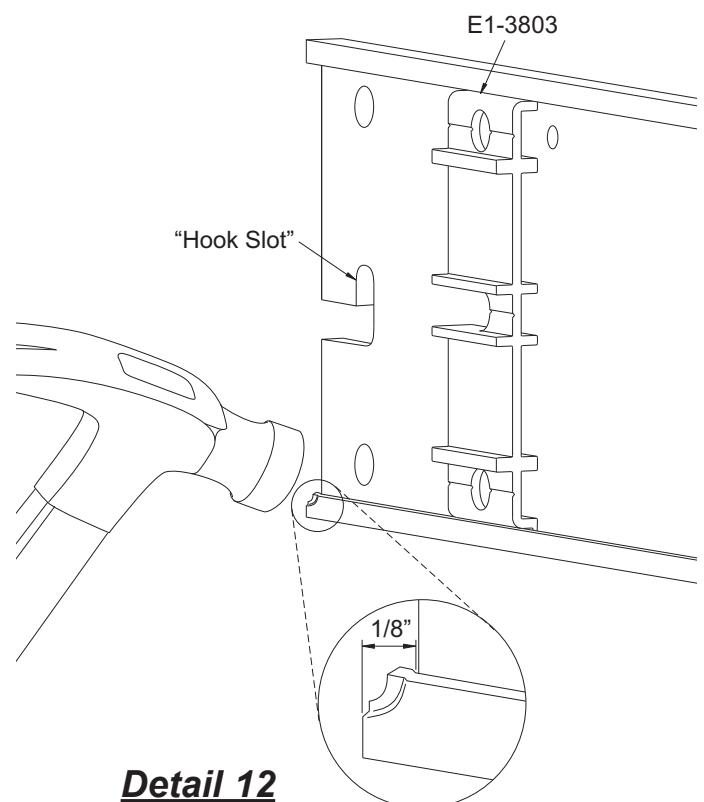

Detail 12

INSTALL THERMASHADE ASSEMBLIES

STEP 6 (Cont'd)

- As previously noted, install the middle bolt, washer, lock washer and nut as shown through the two legs of all the E1-3801 anchor clips.
- Lift the assembly until the outrigger “hook slot” is aligned with the pre-positioned anchor clip thru bolt. insert assembly onto the thru bolts until the assembly drops and engages the thru bolt in the hook.
- After the outrigger assemblies have been placed in this position, slide the spacer back over the bolt.
- Continue to hang remaining ThermaShade assemblies onto the anchor clips in the same manner, making sure to slide the spacers into position for each unit.
- The remaining two anchor clip bolts, washers, and jamb nut can be inserted at any time during the installation sequence when two adjacent assemblies have been hung, with the exception of the end bay anchor clip. Finger tighten only.

Note: For curved (plate type) outrigger, the E1-3803 spacer must be slid into place after adjacent ThermaShade assemblies are hung in place. Then insert two (2) 2" x 3/8" HM-3832-SS bolts.

See **Detail 13**.

- At the outside edge of the aligned outriggers, insert silicone sealant into bottom of outrigger tracks and slide the outrigger connector E1-3804 down the outrigger tracks approximately three to four inches. Check assemblies for level and tighten the three anchor bolts snug.

Installation Tip: Use a clamp to bring together two outriggers that may have bent away from each other, preventing the insertion of the outrigger connector.

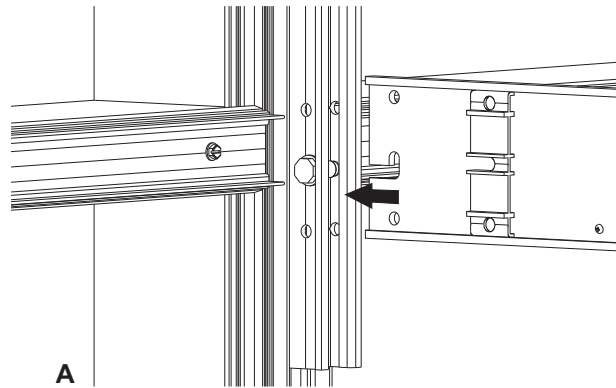

A

Detail 13

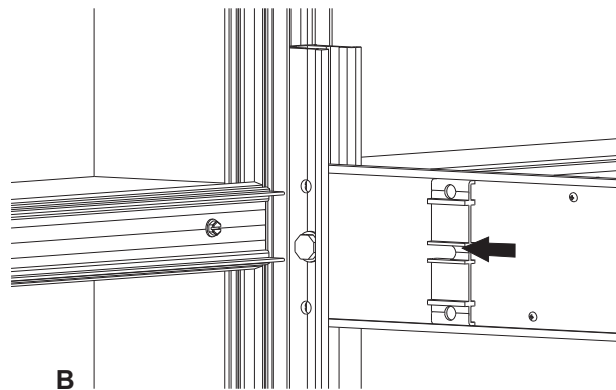

B

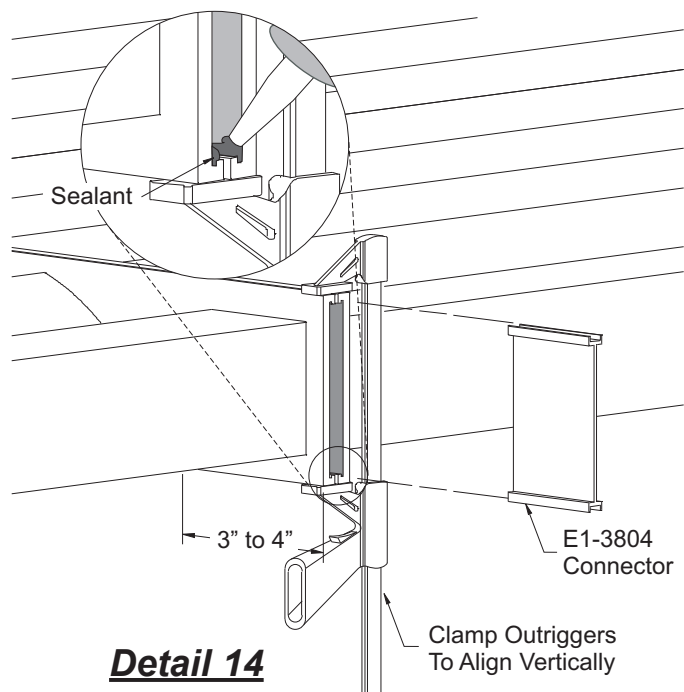

Detail 14

INSTALL THERMASHADE ASSEMBLIES

STEP 6 (Cont'd)

- Repeat above instructions for the remaining intermediate ThermaShade units.
- After the assemblies are aligned, tighten all anchor clip thru-bolts.

See **Detail 13, Page 20.**

INSTALLATION OF END BAY OUTRIGGERS

End bay outriggers only have three attachment holes, to align with the anchor clip and are used to “cap off” the end bay assembly.

- To complete the end bay assemblies, hang an end bay outrigger onto the outermost anchor clips.
- Insert the remaining two thru-bolts and tighten all three bolts only after the assembly is in place.
- Insert E1-3804 connector (see below).

See **Detail 15.**

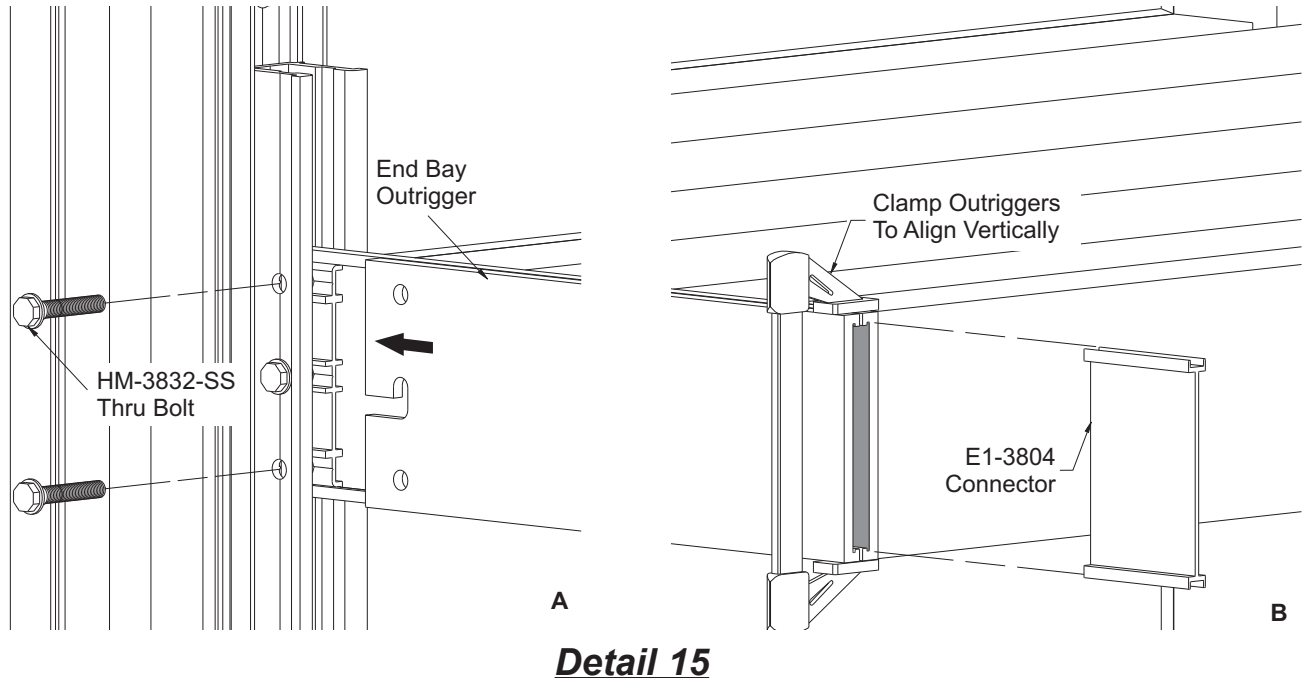

Detail 15

- If optional medallions are used, see **Details 16 and 17** on Page 13 for proper installation.

INSTALL THERMASHADE ASSEMBLIES

STEP 6 (Cont'd) INSTALL MEDALLIONS

Note:

Medallion E1-3809 and Medallion Spacer E1-3810 are required when using the wedge outrigger. Medallion E1-3807 and Medallion Spacer E1-3808 are optional for all other outriggers.

If medallions are to be used, the final intermediate and bay end outriggers must be fabricated to accept the medallion and spacer.

- Locate and drill a 0.281" diameter clear hole in the end bay outrigger.
- Locate, drill and tap a 0.213" diameter hole for a 1/4"-20 thread at the same location in the adjoining intermediate outrigger.

Note: Mark each ThermaShade assembly by referencing the units to the shop drawings. This will simplify installation and assure that the end bay assemblies will not be used in intermediate positions within the array.

- To install the medallion, insert the spacer between the outriggers and then insert the threaded post of the medallion through the clear holes in the end bay outrigger and the spacer. Rotate medallion counter clockwise until threads engage. Then rotate clockwise until snug.

See **Detail 16**.

Locate medallions E1-3807 and E1-3809 as shown below.

See **Detail 17**.

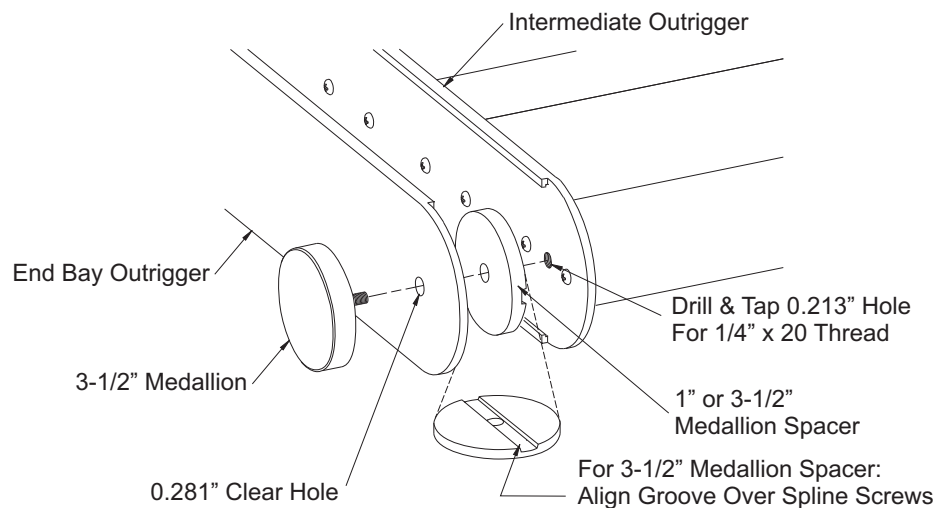

Detail 16

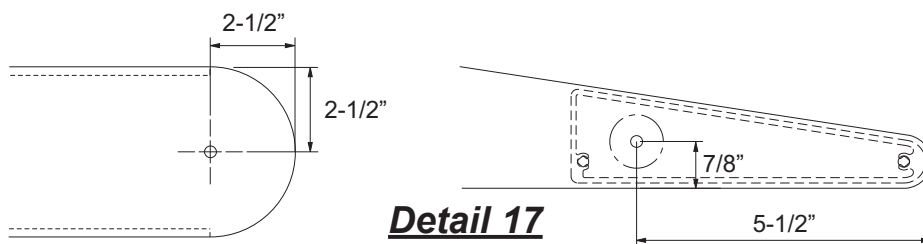

Detail 17

INSTALL FACE COVERS

STEP 7 INSTALL FACE COVERS

-For extruded outriggers, notch the bottom of the top E9-3704 face cover as shown.
See **Detail 18A**.

-For plate outriggers, notch the bottom of the top E9-3704 face cover as shown.
See **Detail 18B**.

-Apply sealant to the inside of the bottom cover to hold splice plates in place. Adhere two E1-3806 splice plates to bottom cover. Slide bottom cover underneath outrigger and snap onto the pressure plate.

-Apply sealant to exposed area of splice plates. Attach notched top cover in place.

-Apply and tool sealant on face cover seams as well as notched area around outrigger to prevent water infiltration.

FC-0808-SS

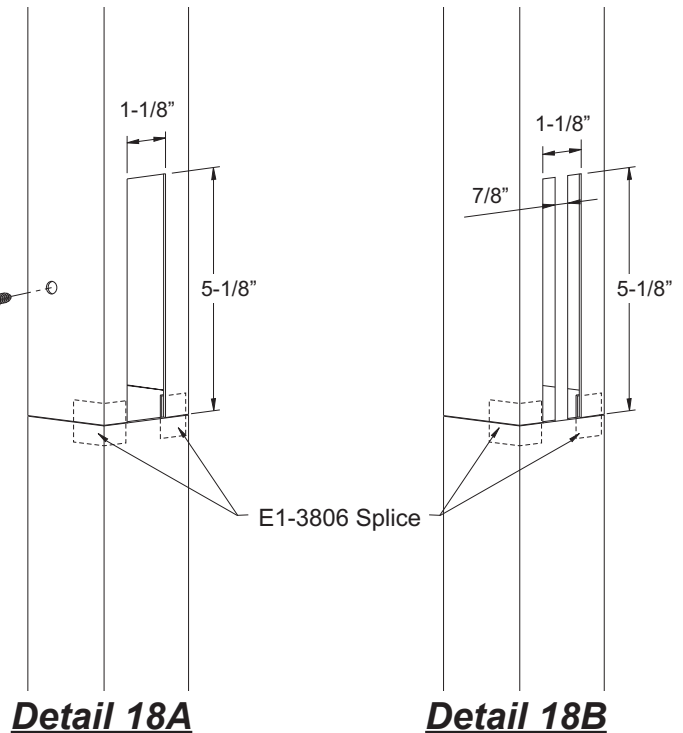

Note: 2-1/4" Deep Covers MUST be fastened 3" from the bottom or at one horizontal cover location with a FC-0808-SS fastener. (Drill 0.141" clear hole).

See **Detail 19**.

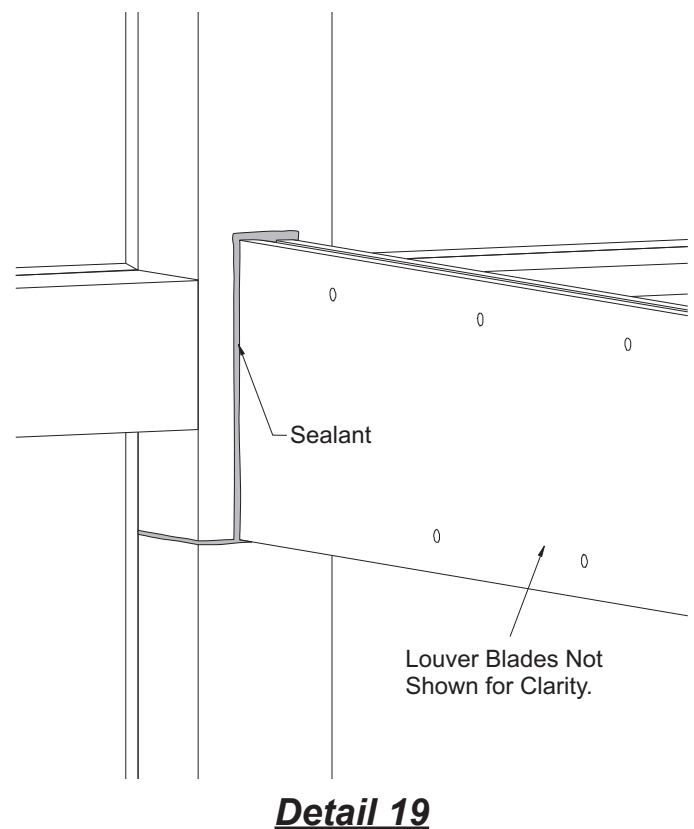

**Optional End Caps for Use With
Square Outriggers Only:**

-Apply a dab (small amount) of sealant on the sides of the optional E1-3805 end cap and tap into place. E1-3804 outrigger connectors must be used when end caps are specified.

See **Detail 20**.

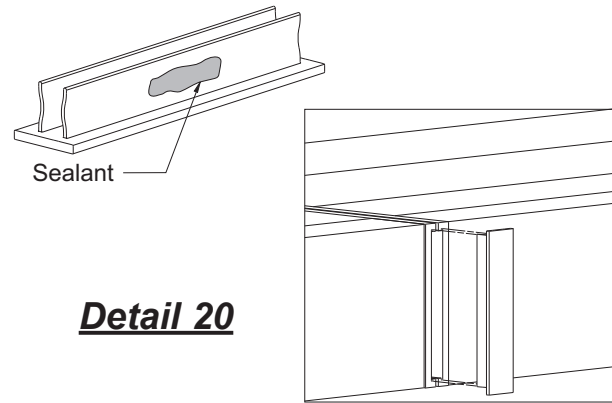

Detail 20

INSIDE CORNER INSTALLATION**STEP 1
ANCHOR CLIP ATTACHMENT**

-Install mullion anchors to the inside corner mullions identical to the installation of the standard mullion anchors.

See **Detail 21**.

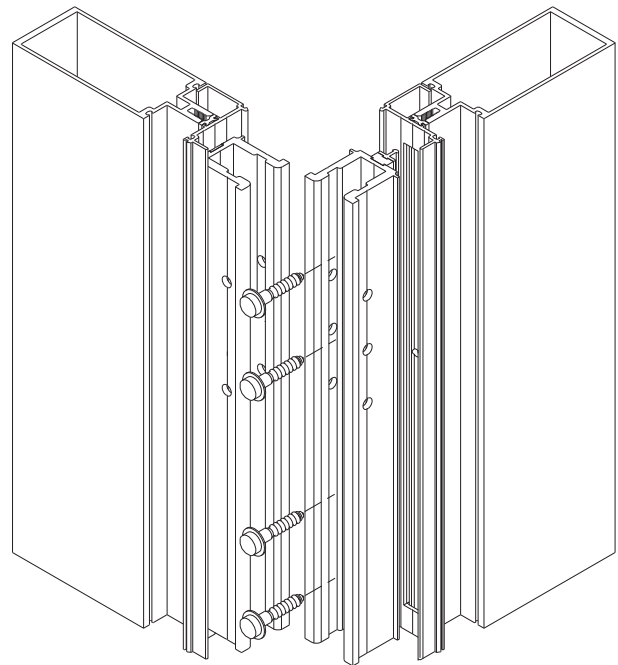

Detail 21

INSIDE CORNER INSTALLATION

STEP 2 INSIDE CORNER OUTRIGGER INSTALLATION

- To install the first half assembly of the inside corner, preinstall the left and right 3/8" bolts, HM-3832-SS, to hang the sunshade on.
- Lift the sunshade assembly and drop it into the slotted holes. Then slide the assembly up to one half of an inch away from the inside corner until the assembly slides no further.

See **Detail 22**.

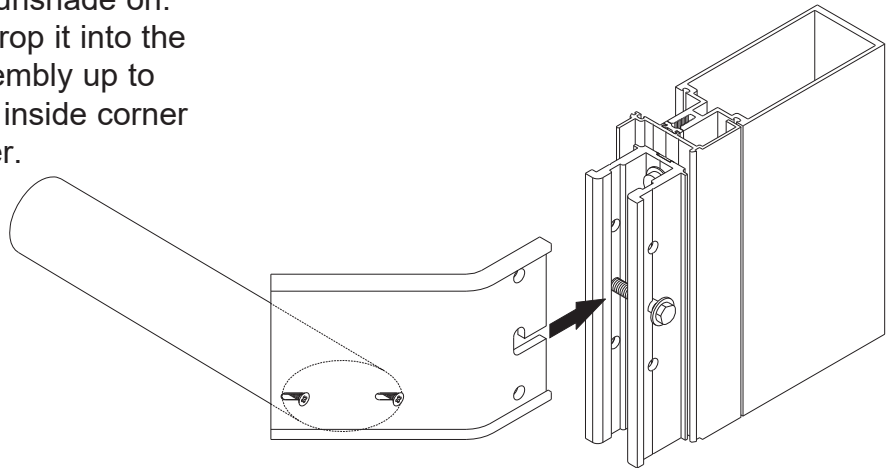

STEP 2 (Cont'd)

- Repeat for the second half of the corner. After both units are hanging, install the remainder of the HM-3832-SS bolts. Align the outriggers together at the corner to achieve a proper gap.
- Shim on both sides of all six (6) of the 3/8" bolts, HM-3832-SS, with a structural non-metallic shim or stacked washers.
- Tighten after alignment.

See **Detail 23**.

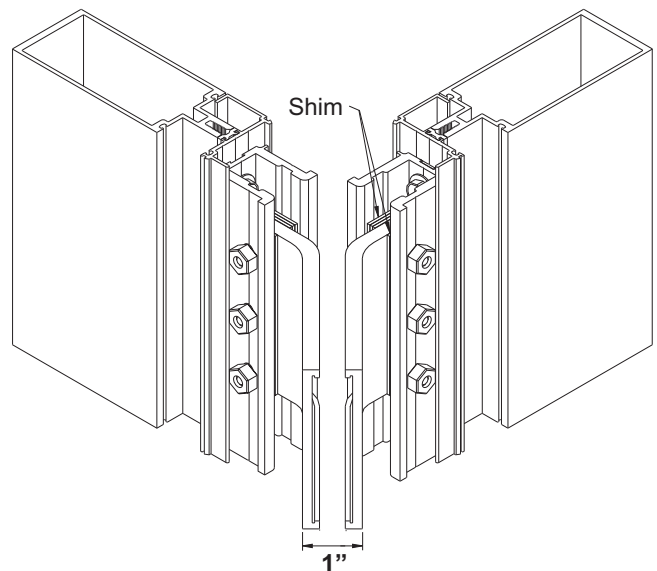

Detail 23

INSIDE CORNER INSTALLATION

**STEP 3
INSTALL FACE COVERS**

-Place a vertical cover above or below the outrigger and mark the location of the notch required on the vertical cover. Notch cover as shown.

See **Detail 24**.

Detail 24

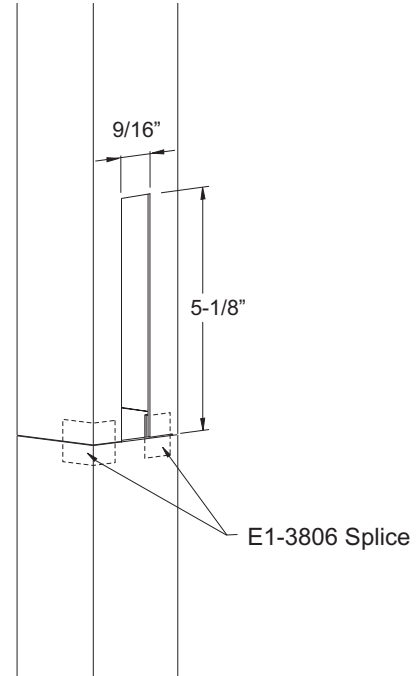

STEP 3 (cont'd)

-Attach notched covers and silicone between the cover and the outrigger.

See **Detail 25**.

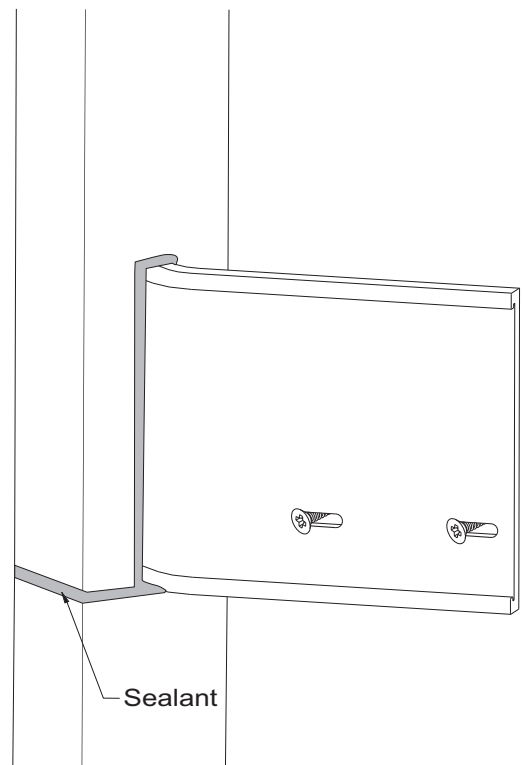

Detail 25

OUTSIDE CORNER INSTALLATION

STEP 1 ANCHOR CLIP ATTACHMENT

-After the jamb adapters are installed to the mullions, install mullion anchors to the outside corner mullions similar to the installation of the standard mullion anchors. Refer to YKK AP standard corner drawings found on the YKK AP Architectural Product Master.

See **Detail 26**.

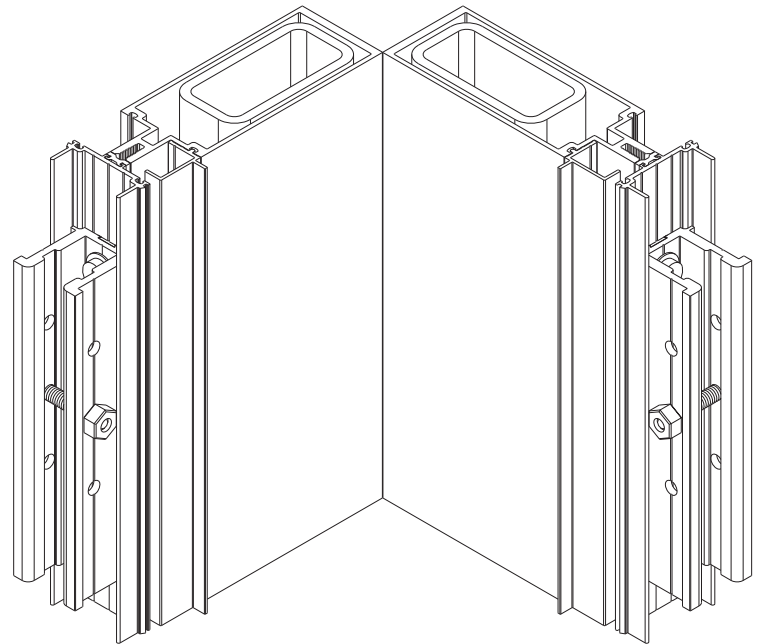

Detail 26

- Place the steel anchor (centered vertically with the centerline of the mullion clips and outriggers) and position into place.
- Locate the slotted holes in the steel anchor and drill a #3 hole to attach the steel anchor into the side of the mullion, threading into the steel reinforcing. (Minimum 3 feet long, centered on the outrigger).
- After positioning correctly, install the corner steel anchor into the mullion's steel reinforcing at the top two slotted holes with a 1/8" shim and a HF-2528-W1 fastener.
- The slots in the steel anchor are for a final adjustment.

See **Detail 27**.

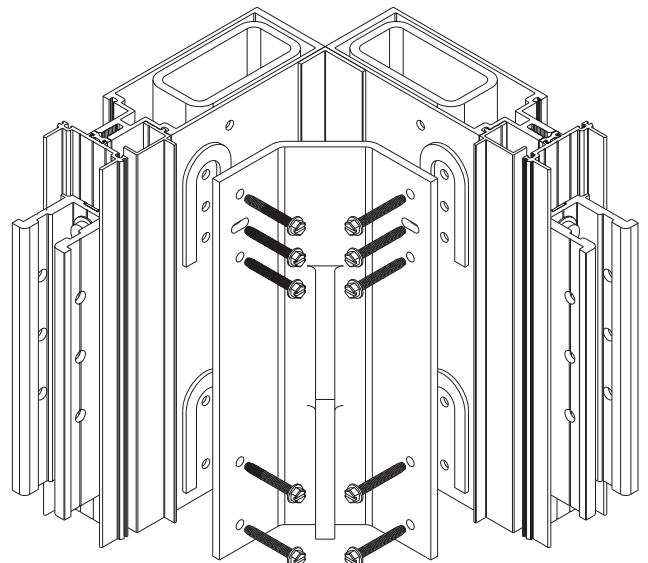

Detail 27

OUTSIDE CORNER INSTALLATION

STEP 2

OUTSIDE CORNER OUTRIGGER INSTALLATION

- To hang the sunshade, place the outrigger assembly into the adjacent outrigger's 3/8" bolt and bring the assembly's corner outrigger up against the steel anchor.
- Temporarily bolt the louver assembly into one of the 3/8" clear holes in the steel anchor.
- Before installing the second half of the corner outrigger, silicone will be required between the outriggers where it aligns with the face of the breakmetal. To do so, seal the inside of the outrigger where it will align with the face of the breakmetal. Place E2-3801 into the silicone area. Before installing the remaining sunshade corner section, seal over the dry side of E2-3801 with silicone sealant. See **Detail 28**.
- Guide the second half of the assembled outrigger into place similar to the first half.
- Add the (2) remaining 3/8" bolts to the standard outriggers immediately next to the corner.

See **Detail 29**.

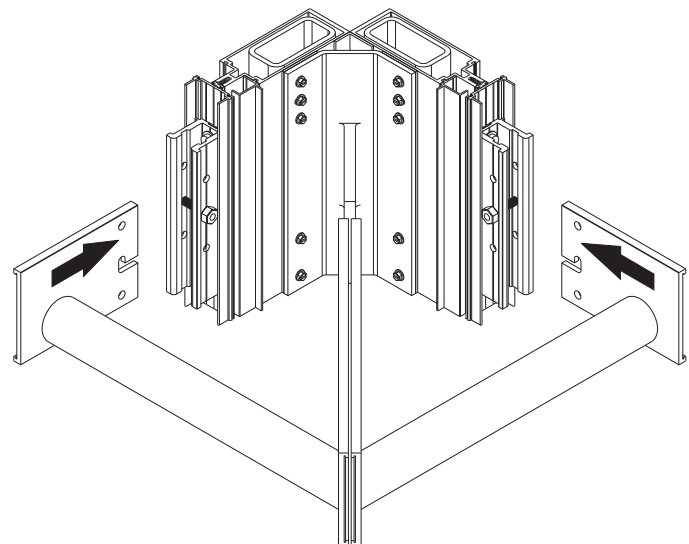
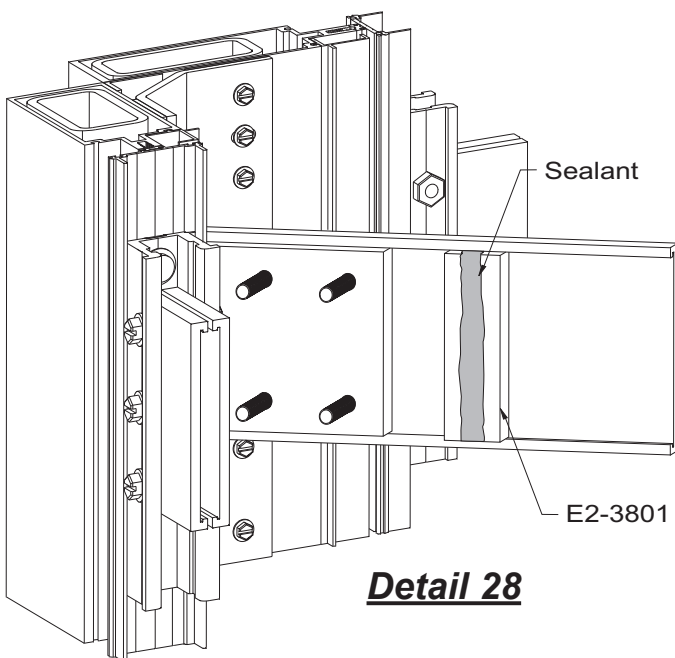

STEP 2 (Cont'd)

After both halves are in place, align the corner outriggers to their correct position by sliding the assemblies across the slotted steel anchor hole, or by shimming between the steel anchor hole, or by shimming between the steel anchor and the mullions.

Confirm the outriggers are aligned, then add the eight remaining HF-2528-W1 bolts

See **Detail 30**.

OUTSIDE CORNER INSTALLATION

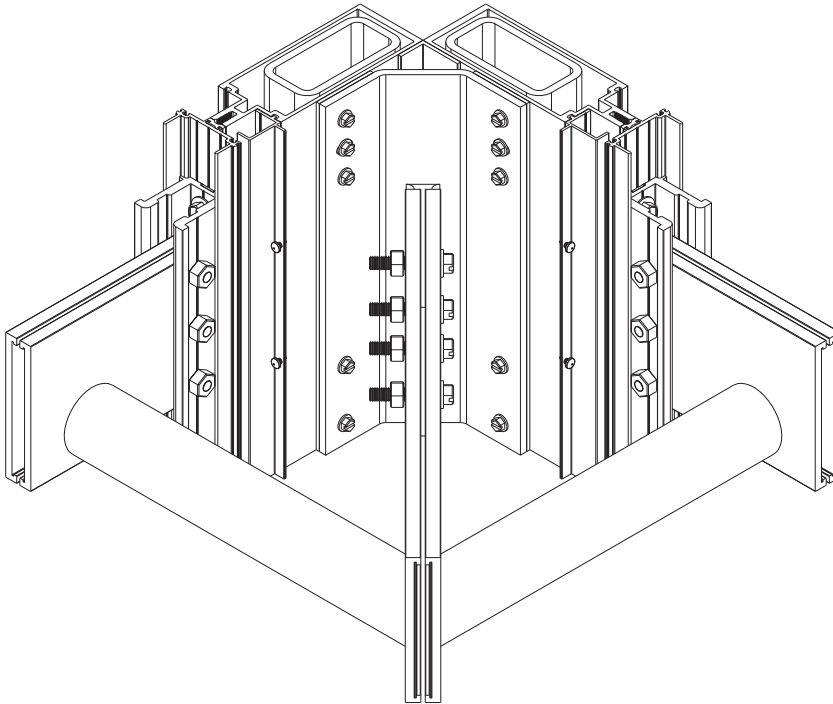

Detail 30

STEP 3 BREAKMETAL INSTALLATION

- After all of the components are tight, breakmetal can be added between the two vertical covers.
- Notch the breakmetal as shown in **Detail 31**.

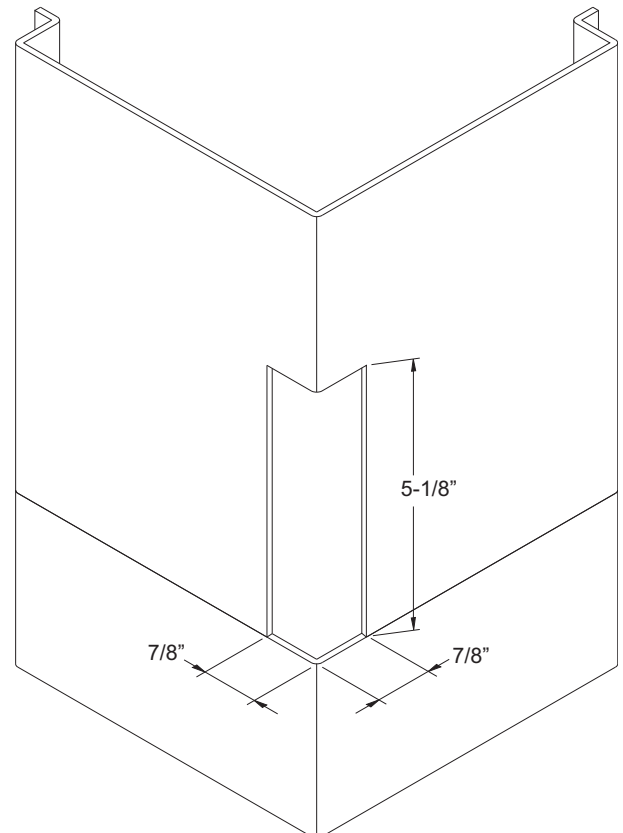

Detail 31

OUTSIDE CORNER INSTALLATION**STEP 3 (Cont'd)**

-Seal the gap where the breakmetal has been notched to allow the outrigger to run thru.
See **Detail 32**.

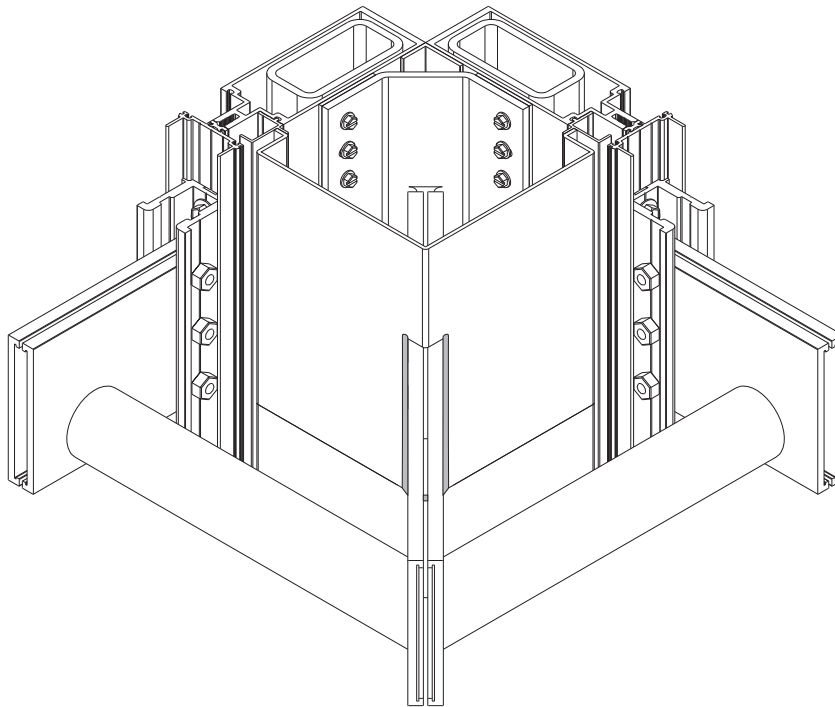

Detail 32

MITERED COVER INSTALLATION

STEP 1

Mitered covers are an option on YKK curtain walls when the standard 3/4" covers are required in lieu of the deeper covers typically used on Thermashade. The E1-3833 mitered cover is a two piece design (18" total length) that snaps on to the E1-3834 notched pressure plate and requires a seal as shown in **Detail 33**.

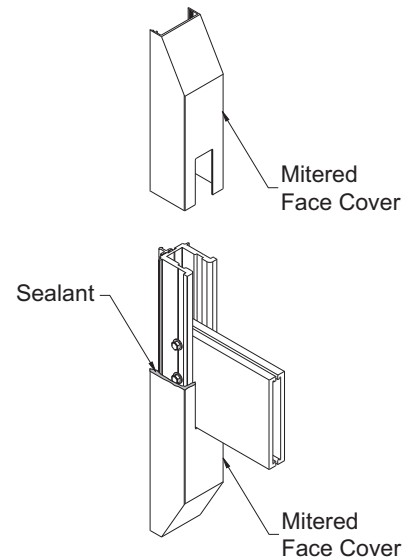

Detail 33

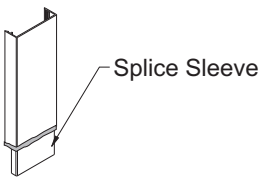

Splice sleeves are to be used above and below where the mitered cover transitions into the standard cover.

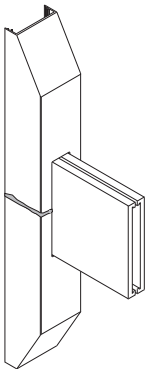

- Seal between the two mitered covers where they join on the sides, between the cover and mullion anchor. See **Detail 34**.
- After the mitered covers are snapped on, bring in the 3/4" covers with the E1-1202 splices (E1-3009 for YHC 300) attached and slide the splice into the 3/4" end of the mitered covers.
- Before the standard cover is completely attached, add sealant to the joint of the covers.
- After all covers are attached, wipe the sealant clean at all intersections. See **Detail 35**.

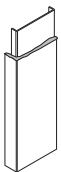

Detail 34

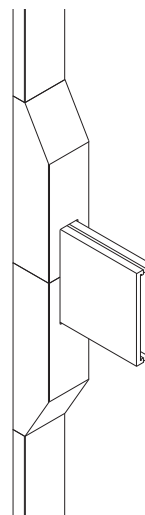

Detail 35

YHC300 OG (E9-3101 & E9-3183) ANCHOR CLIP PREPARATION

The following must be done prior to the pressure plate installation. Before the pressure plate has been installed, run a 12" line of silicone sealant (centered on the outrigger) to fill both sides of the recess in the mullion tongue as shown. Tool smooth and allow to cure before drilling for mullion anchor attachment.

See **Detail 36**.

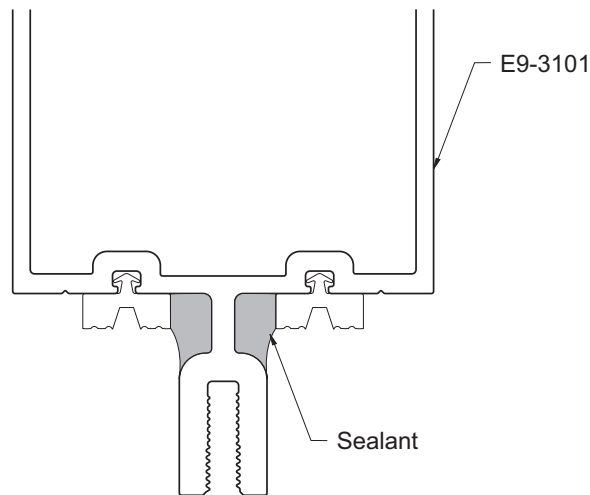

Note: YHC 300 insulating glass mullions use HW-3840-SS fasteners.
 YHC 300 monolithic glass mullions use HW-3832-SS fasteners.

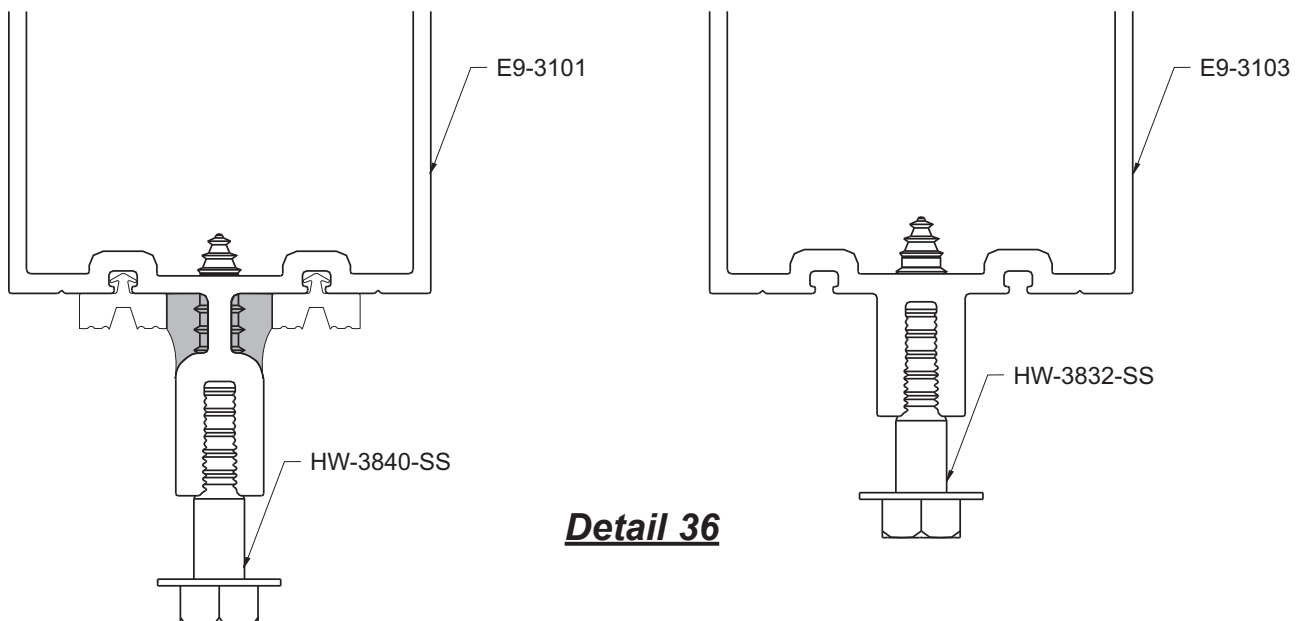

Detail 36

**24" THERMASHADE
MAX. END REACTIONS-SHEAR
AT THE ATTACHMENT POINT**

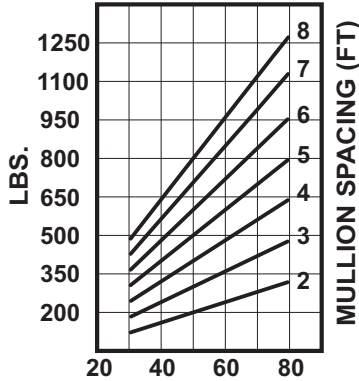

ALLOWABLE COMBINED LOAD (PSF)

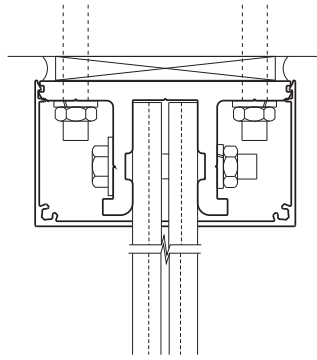

**24" THERMASHADE
MAX. END REACTIONS-MOMENT
AT THE ATTACHMENT POINT**

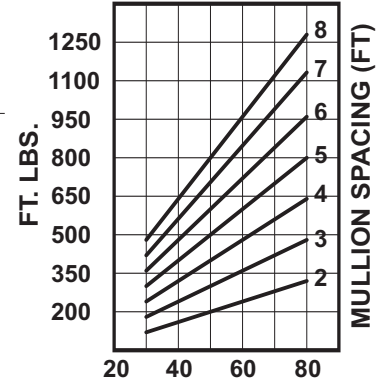

ALLOWABLE COMBINED LOAD (PSF)

**30" THERMASHADE
MAX. END REACTIONS-SHEAR
AT THE ATTACHMENT POINT**

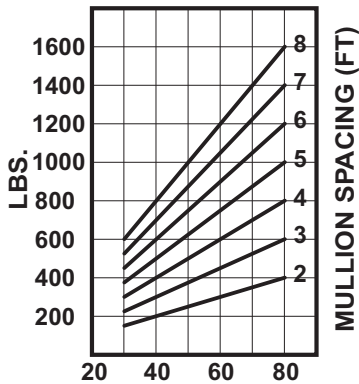

ALLOWABLE COMBINED LOAD (PSF)

**30" THERMASHADE
MAX. END REACTIONS-MOMENT
AT THE ATTACHMENT POINT**

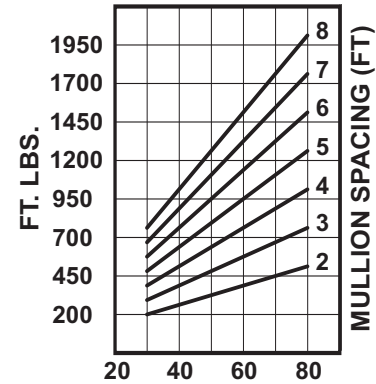

ALLOWABLE COMBINED LOAD (PSF)

**36" THERMASHADE
MAX. END REACTIONS-SHEAR
AT THE ATTACHMENT POINT**

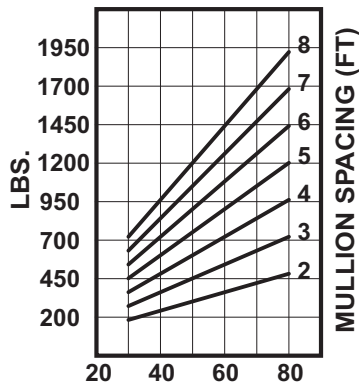

ALLOWABLE COMBINED LOAD (PSF)

**36" THERMASHADE
MAX. END REACTIONS-MOMENT
AT THE ATTACHMENT POINT**

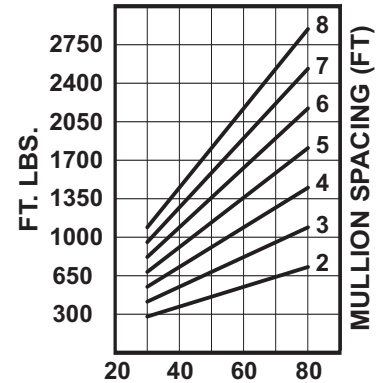

ALLOWABLE COMBINED LOAD (PSF)

*Wall Mount attachment refers to anchoring ThermaShades to various building facade conditions other than aluminum framing systems. It is the responsibility of others (not YKK AP) to ensure the facade condition and anchor attachments are capable of withstanding the reactions applied as shown on these charts.

WALL MOUNT ATTACHMENT

The wall mount sunshade attachment is designed to allow ThermaShade[™] sunshades to attach to wall conditions other than YKK AP framing members. The wall condition, however, must be designed in such a way as to provide adequate structure to withstand the combined loads on the sunshades. The building's Engineer of Record will need to verify the loads and the structural design. The shear force and moment of each sunshade attachment varies per the combined load and the width of the sunshades. Refer to YKK AP's Shear and Moment charts on Page 31 to determine the end reactions at the attachment point.

STEP 1 ANCHOR CLIP ATTACHMENT

Attach anchor E1-3830 to the buildings structure with fasteners designed for the specific structure. The anchor is prepped for 3/8" fasteners 2-3/4" apart horizontally and 9" vertically. See **Detail 37**.

The anchor is designed to attach to a steel beam or steel anchor. See **Detail 38 & Detail 39**.

Up to 3/8" of structural shims can be placed behind the anchor and the wall attachment point.

Using the anchor as a template, mark the 4 holes and drill for the appropriate fasteners. The anchors must be plum and true to properly install the sunshades.

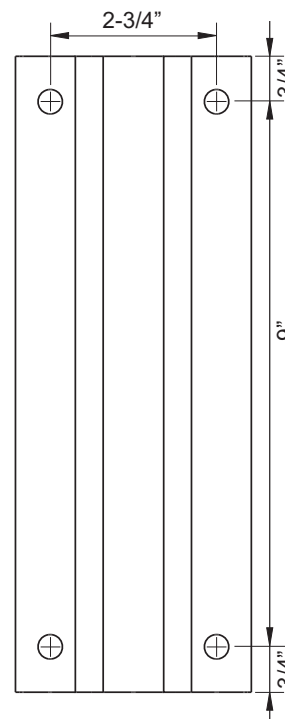

Detail 37

WALL MOUNT ATTACHMENT (Cont).

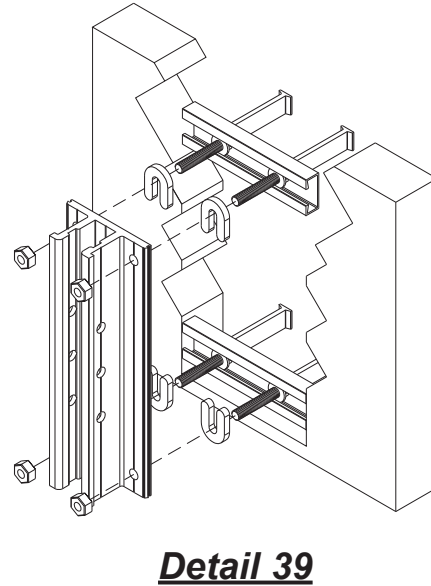
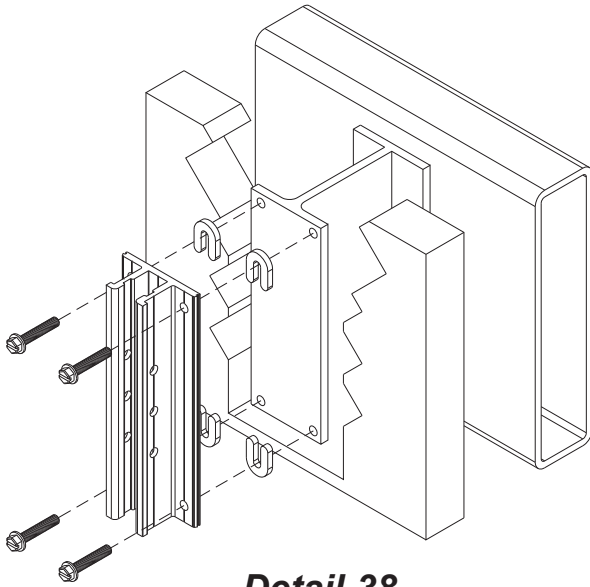

STEP 2 ADD SILICONE

After the anchor is positioned and tight, a full perimeter seal around the anchor at this point and around the bolt head is required to keep the area watertight.

Note: The snap engagement for the cover must be kept clean and free of any silicone or debris.

See **Detail 40**.

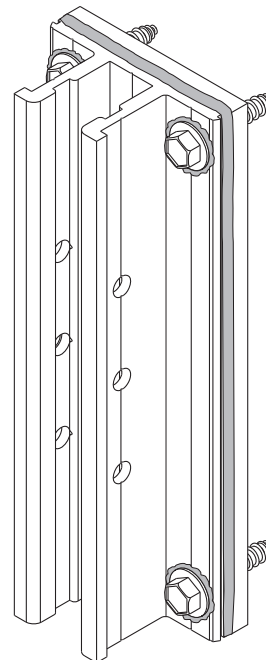

WALL MOUNT ATTACHMENT (Cont.)

STEP 3 ATTACH LOUVERS AND FASCIA

Due to the nature of drilling into an unknown structure, it is recommended that the louvers and fascia be cut after the anchors are installed. To measure the length of the louvers and fascia, place the tape measure from the inside leg of one anchor to the next, (similar to Detail 1 on page 10).

STEP 4 INSTALL OUTRIGGERS

Install the outriggers similar to the standard Curtainwall outriggers shown on **Pages 17 to 21**.

STEP 4 INSTALL FACE COVERS

A two piece cover E1-3831, with two E1-3832 end caps will cap off the anchor. Fasten with two FC-1008-SS fasteners per cap. Seal the connection at the joints of the cover and the caps with silicone sealant.

-Snap on the bottom cover. Seal the top of the bottom cover where the top cover will join.

See **Detail 41**.

-Snap fit the top cover into place and wipe off excess sealant for a clean appearance.

See **Detail 42**.

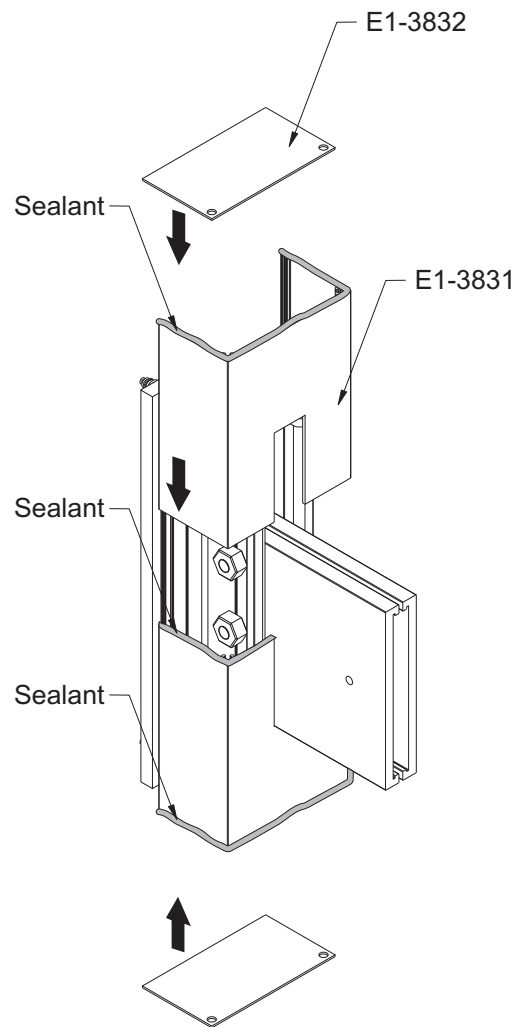

Detail 41

WALL MOUNT ATTACHMENT (Cont.)

STEP 4 (Cont.) INSTALL FACE COVERS

-Apply and tool sealant to notched area around
outrigger to prevent water infiltration.

See **Detail 42**.

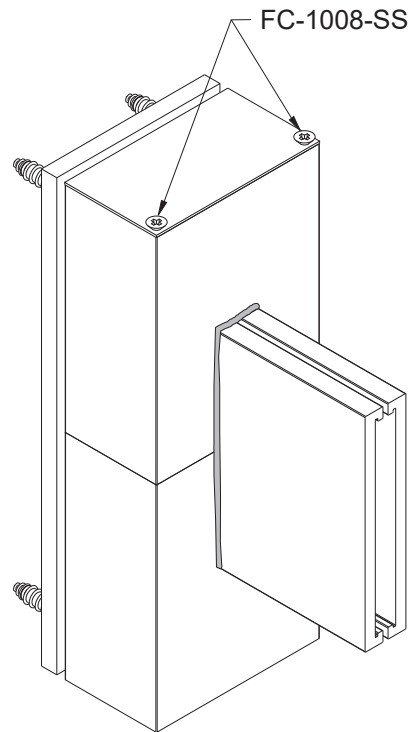

Detail 42

REGLAZING INSTRUCTIONS**REGLAZING CURTAIN WALL**

ThermaShade assemblies must be removed to allow access to glass for reglazing.

The adjacent assemblies must also be removed on both sides of the replaced glass to allow for setting. For example, three ThermaShade assemblies must be removed for one piece of glass, four removed for two, etc.

- If the E1-3805 optional end caps were used, pry them off of the front of the assemblies.
- If the E1-3804 outrigger connectors were used, slide them out the front of the outriggers.
- Carefully remove the snap on face covers above the outriggers on both sides of the broken glass area to expose the three HM-3832-SS through bolts.
- Loosen and remove the top and bottom bolts. Loosen the center bolt until finger-tight.
- At this point the outrigger can be lifted 3/8" and pulled away from the glass.
- Carefully remove the four 3/8" diameter lag screws holding in the anchor clip.

Note: After the glass has been replaced, follow the standard installation instructions for replacing the ThermaShade assemblies that had to be removed. It is important that care be taken when re-inserting the anchor clip lag screws, so that new threads are not cut. Rotate the lag screws counter clockwise until the threads engage the thread paths of the original installation.

- Remove the horizontal pressure plates and replace with small temporary glazing retainers.
- Remove the vertical pressure plates, carefully cutting the silicone at the joint plugs.
- Check and clean all surfaces as required for glazing per curtain wall instructions.



101 Marietta Street NW
Suite 2100
Atlanta, Georgia 30303
www.ykkap.com