

YSD 700/700 H Sliding Door System for Insulating Glass

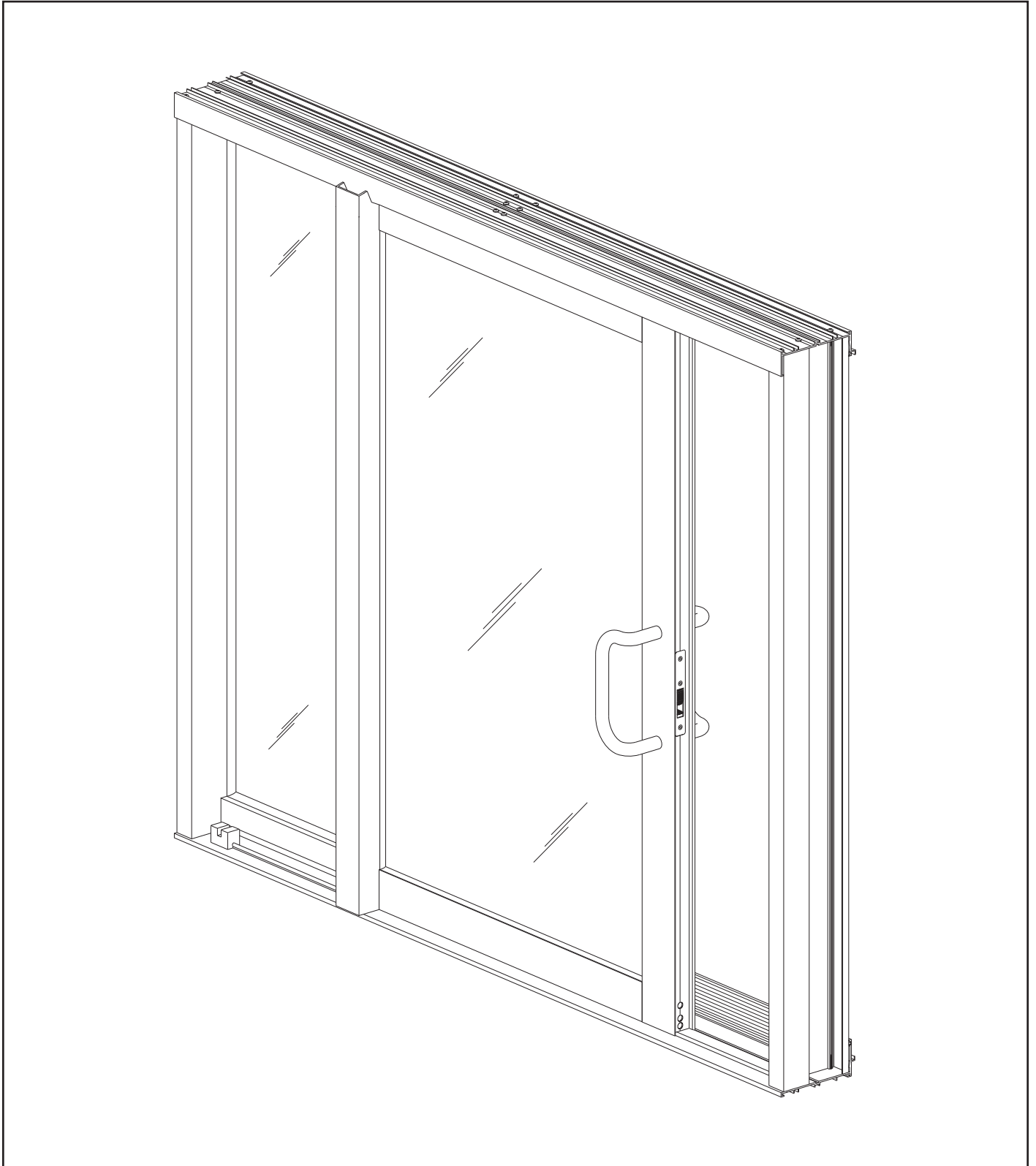

Installation Manual

TABLE OF CONTENTS

Installation Notes	Page ii & iii
PARTS DESCRIPTION	
Framing Members	Page 1 & 2
Accessories	Page 2 to 4
ASSEMBLE SLIDING PANELS	
Install Glazing Gaskets for Non-Impact & Small Missile	Page 5
Install Glazing Spacers & Side Blocks for Large Missile.....	Page 6
Glazing Sliding Panels.....	Page 7 to 9
Apply Structural Silicone for Large Missile.....	Page 9
Attach Pull Handles	Page 9
ASSEMBLE SLIDING DOOR FRAME	
Assemble Sliding Door Frames.....	Page 10 & 11
Prep Head & Sill Fillers	Page 12
Attach Fixed Panel Head & Sill Fillers.....	Page 12
INSTALL SLIDING DOOR FRAME	
Anchor Sliding Door Frame	Page 13 & 14
Apply Perimeter Sealant.....	Page 15
GLAZE FIXED PANELS	
Install Interior Glazing Gaskets (Non-Impact & Small Missile).....	Page 16
Glaze Fixed Panels (All Panels).....	Page 17
Apply Interior Structural Silicone Sealant (Large Missile).....	Page 18
Attach Sliding Panel Head & Sill Fillers.....	Page 19 & 20
INSTALL SLIDING PANELS	Page 21
CALCULATING GLASS SIZES	Page 22









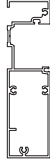

INSTALLATION NOTES

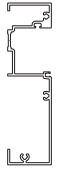
1. Do not drop, roll or drag boxes of aluminum framing. Move and stack boxes with proper support to prevent distortion. If fork lifts are used, be especially careful about striking the boxes when lifting or moving.
2. Store in a dry, limited access area. If rain exposure, condensation or any water contact is likely, then all packaging material should be removed. Wet packaging materials may permanently discolor or stain aluminum finishes and paints.
3. All materials should be checked for quantity and quality upon receipt, YKK AP must be notified immediately of any discrepancies in shipment. Check to make sure that you have the required shims, sealants, supplies, and tools necessary for the installation.
4. Carefully check the openings and surrounding conditions that will receive your material. If the construction is not per the construction documents, it is your responsibility to notify the general contractor in writing. Any discrepancies must be brought to the general contractor's attention before you proceed with the installation.
5. Collect your shop drawings, materials, packing list, and this installation manual. Carefully review parts location and the sequence of installation, including glazing and sealing. Installation instructions are of a general nature and may not cover every condition you will encounter. The shop drawings and/or installation manuals were prepared specifically for the product.
6. Any material substitutions must be of equal or greater quality.
7. Make certain that material samples have been sent for compatibility testing for all manufacturer's sealants involved. Make certain that sealants have been installed in strict accordance with the manufacturer's recommendations and specifications.
8. Consult sealant manufacture for proper sealant and backer rod selection.
9. Remember to isolate, in a approved manner, all aluminum from uncured masonry or other incompatible materials.
10. System-to-structure fasteners are not supplied by YKK AP. Fasteners called out on shop drawings are to indicate minimum sizes for design loading.
11. If any questions arise concerning YKK AP products or their installation, contact YKK AP Technical Center for clarification before proceeding.

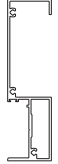

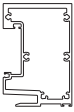
INSTALLATION NOTES

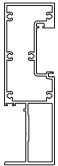
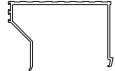
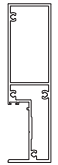
12. YKK AP sliding door installation is typically completed before drywall, flooring and other products have been completely installed. Take the extra time to wrap and protect the installed material.
13. YKK AP Model YSD 700 sliding doors are prefinished and prefabricated, sometimes preassembled, and must be protected against damage.
14. Concrete, mortar, plaster, muriatic acid and other alkaline and acid based construction and cleaning materials may be very harmful to finishes and should be removed with water and mild soap immediately or permanent damage or staining of the finishes will occur. A spot test is recommended before any cleaning agent is used. Abrasive type cleaners must never be used.
15. All work must start from, and be referenced to benchmarks, offset lines and/or column centerlines established by the architectural drawings and the general contractor.
16. All doors must be installed plumb, square, level, and true, and in accordance with approved shop drawings and these installation instructions.
17. Glass and glazing building codes governing the design and use of products vary widely. YKK AP America Inc. does not control the selection of products, product configurations, operating hardware and function, or glazing materials, and YKK AP assumes no responsibility for these design considerations. It is the responsibility of the design professional, owner, architect, specifier, general contractor, and the installer to make these selections in strict accordance with all applicable codes.
18. Check our website, www.ykkap.com, for the latest installation manual update prior to commencing work.



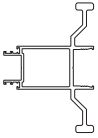
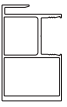
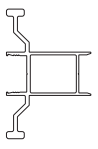

YSD 700 FRAMING MEMBERS

 <p>Head</p>	<p>E9-6126</p>	 <p>Fixed Jamb (Hollow)</p>	<p>E9-8022</p>
 <p>Sill</p>	<p>E9-6127</p>	 <p>Head Filler For Fixed Panels</p>	<p>E9-6107</p>
 <p>Fixed Jamb</p>	<p>E9-6103</p>	 <p>Head Filler Glass Stop For 1" to 1-3/16" Insulating Glazing</p>	<p>E9-6109</p>
 <p>Lock Jamb</p>	<p>E9-6104</p>	 <p>Sill Filler For Fixed Panels</p>	<p>E9-6108</p>
 <p>Interlock Mullion</p>	<p>E9-6105</p>	 <p>Head Filler For Sliding Panels</p>	<p>E9-6110</p>
 <p>Lock Stile Mullion For OXO</p>	<p>E9-6106</p>	 <p>Sill Filler For Sliding Panels</p>	<p>E9-6111</p>
 <p>Door Jamb</p>	<p>E9-6135</p>	 <p>Frame Head Adaptor/Reinforcing</p>	<p>E9-6115</p>

YSD 700 SLIDING PANEL MEMBERS



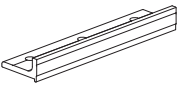

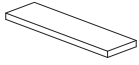
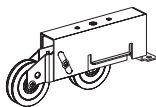
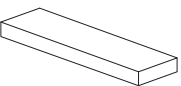
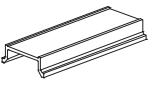
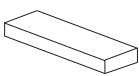















	Top/Bottom Rail	E9-6112		Latch Meeting Stile	E9-6116
	Interlock Stile	E9-6113		Lock Meeting Stile	E9-6117
	Lock Stile	E9-6114			

YSD 700 ACCESSORIES

	Track Cover Stainless Steel	E1-1601*		Reinforcement Clip For OXXO Only Attaches to Bottom of Meeting Stiles	E1-1622*
	Lock Strike	E1-1618*		Reinforcement Angle For OXXO Only Attaches to Head & Sill	E1-1623
	Bottom Rail Block	E1-1605*		Setting Block For Insulating Glazing OX/OXO Non-Impact & Sm. Missile Sliding Panels	E2-0177
	Ball Bearing Rollers Stainless Steel	E1-1620*		Setting/Side Block For Insulating Glazing Fixed Panels (Setting) & Lg. Missile Sliding Panels	E2-0178
	Setting Block Chair For Insulating Glazing Fixed Panels	E1-1619		Setting Block For Insulating Glazing OXXO Non-Impact & Sm. Missile Sliding Panels	E2-0611

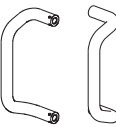

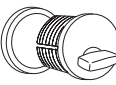











* Parts assembled to door/frame at the factory.

YSD 700 ACCESSORIES

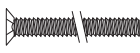
	Side Block For All Insulating Glazing Fixed Panels	E2-0733		Sliding Panel Gasket For Non-Impact & Small Missile 1-3/16" Glazing	E2-0730
	Side Block For Large Missile 1-3/16" Glazing Sliding Panels (Lock Stile Side)	E2-0134		Sliding Panel Gasket For Non-Impact & Small Missile 1" Glazing	E2-0731
	Airtight Gasket For Frame Head & Sill	E2-0051*		Jamb/Meeting Stile Bumper	E2-0705*
	Pile Weathering	E2-0712*		Head/Sill Bumper	E2-0709*
	Exterior Glazing Gasket For 1" Glazing Fixed Panels	E2-0081		Anti-Walk Block For All Non-Impact & Small Missile Glazing Fixed Panels	E2-0546
	Exterior Glazing Gasket For 1-3/16" Glazing Fixed Panels	E2-0082		Plastic Rivet	E3-1165*
	Exterior Glazing Gasket For Large Missile 1-3/16" Glazing Sliding Panels	E2-0361		Anti-Lift Block	E3-1162*
	Interior Glazing Gasket For All Non-Impact & Small Missile Glazing Fixed Panels	E2-0088		Screw Cap	K3-3004
	Interior Glazing Spacer For Large Missile 1-3/16" Glazing Fixed Panels	E2-0089*		Pull Handle Package Shoulder Bolts Included	H-1342
	Interior Glazing Spacer For Large Missile 1-3/16" Glazing Sliding Panels	E2-0732		Thumbturn Cylinder	H-4204*
	Meeting Stile Gasket For OXXO Sliding Panels	E2-0740*		3/16" Cylinder Trim Ring For Thumbturn Cylinder	P-48510*

* Parts assembled to door/frame at the factory.

YSD 700 ACCESSORIES

	MS Lock Hookbolt 1-1/2\" Backset	P-2101*		#10-24 x 1/2\" Type F PHTCS, Stainless Steel For Attachment of Anti-lift Block E3-1162	PF-1008 -SS*
	Face Plate For Hookbolt Lock	P-33118*		#10-24 x 3/4\" Type F PHTCS, Stainless Steel For Attachment of Bumper E2-0705	PF-1012 -SS*
	#8 x 1/2\" Type F FHTCS, Stainless Steel For Attachment of Bottom Block E1-1605	FF-0808 -SS*		#12 x 5/8\" Type AB PHSMS, Stainless Steel For Attachment of Sill Filler to Reinf. Angle E1-1623	PC-1012 -SS*
	#8 x 1/2\" Type F PHTCS, Stainless Steel For Attachment of Ball Bearing Rollers E1-1620 & Head Stopper E3-1162	PF-0808 -SS*		#12 x 1-1/4\" Type AB PHSMS, Stainless Steel For Attachment of Frame, Sill Adaptor & Panels	PC-1220 -SS
	#10-32 x 2-3/8\" FHMS Stainless Steel For Attachment of MS Lock to Lock Stile	FN-1038 -SS		#12 x 1-1/4\" Type AB PHSMS, Stainless Steel For Attachment of Strike E1-1618	PC-1220 -SS*
	#10 x 1/2\" Type AB PHSMS, Stainless Steel For Attachment of Head Adaptor/Reinf. E9-6115	PC-1008 -SS*		#12 x 1\" Type AB FHSMS, Stainless Steel For Attachment of Reinforcement Clip E1-1622	FC-1216 -SS*
	#10 x 1-1/4\" Type AB PHSMS, Stainless Steel For Attachment of E2-0709	PC-1020 -SS*		#10 Self Sealing Washer Stainless Steel, For Attachment of Sill Filler E9-6111 to Sill E9-6127	P-78186 -SS
	#10 x 1\" Type A PHMS Stainless Steel For Attachment of Sill Filler E9-6111 to Sill E9-6127	PA-1016 -SS			

* Parts assembled to door/frame at the factory.

ASSEMBLE SLIDING PANELS

STEP 1A

INSTALL GLAZING GASKETS (NON-IMPACT & SMALL MISSILE PANELS ONLY)

- Lay glass on flat surface with access to all four edges (i.e. lay glass on sawhorses).
- Locate the roll of gasket supplied with the sliding door package.
- Add up the total perimeter for each lite of glass:
 $(2 \times \text{Width}) + (2 \times \text{Height})$
 Ex.: A unit 34" wide by 76" tall would have 220" total.
- Cut the gasket to the length determined above for each lite plus 6".
- Begin by installing the gasket at the center of the top of each lite.

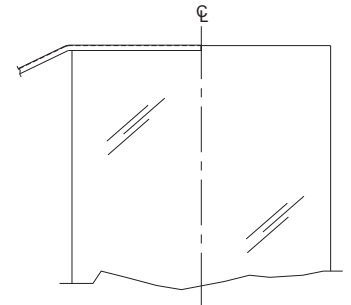

Detail 1

See **Detail 1**.

- Cut the gasket 1/2" away from the corner.
- Cut the gasket squarely.

Caution: Do not cut through the trim lip of the gasket.

See **DETAIL 2**.

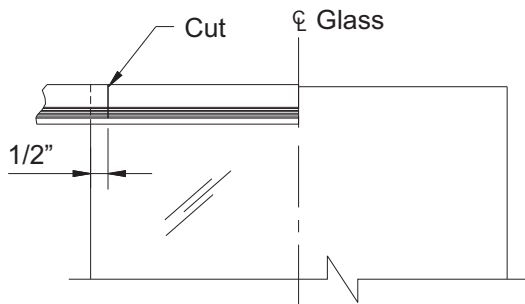

Detail 2

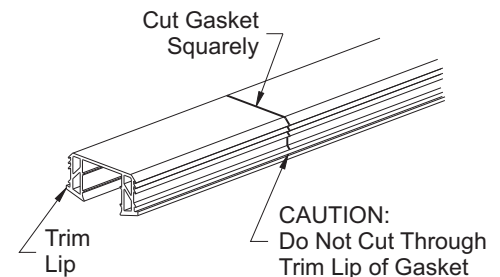

- Wrap the gasket around the corner and install the gasket around the glass moving down the side of the lite.

See **DETAIL 3**.

- Cut the gasket 1/2" away from the next corner.
- Proceed around the lite repeating the steps called out above.
- Trim off the excess gasket at the end and butt the ends of the gasket against each other, allowing an extra 1/4" to ensure a tight fit.

See **DETAIL 4**.

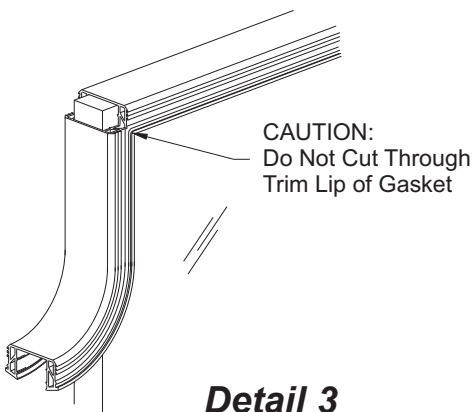

Detail 3

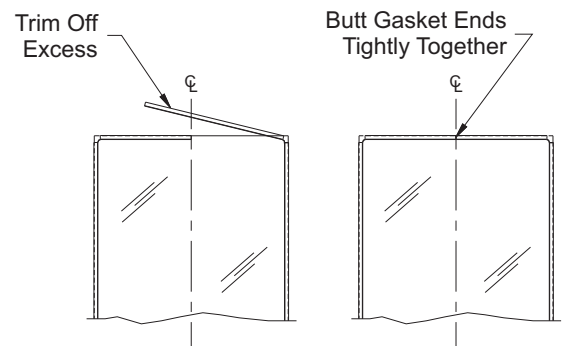

Detail 4

ASSEMBLE SLIDING PANELS

STEP 1B

INSTALL GLAZING SPACERS & SIDE BLOCKS (LARGE MISSILE PANELS ONLY)

Large missile sliding panels require the installation of glazing tape, E2-0732, prior to assembling the panel members.

- Cut top/bottom rail glazing tape to the Panel Daylight Opening.
- Cut stile glazing tape to the Stile Length minus(-) 5".
- Remove the protective backing from the glazing tape and apply it as shown below. Be careful not to stretch the tape when installing it.

See **Detail 5**.

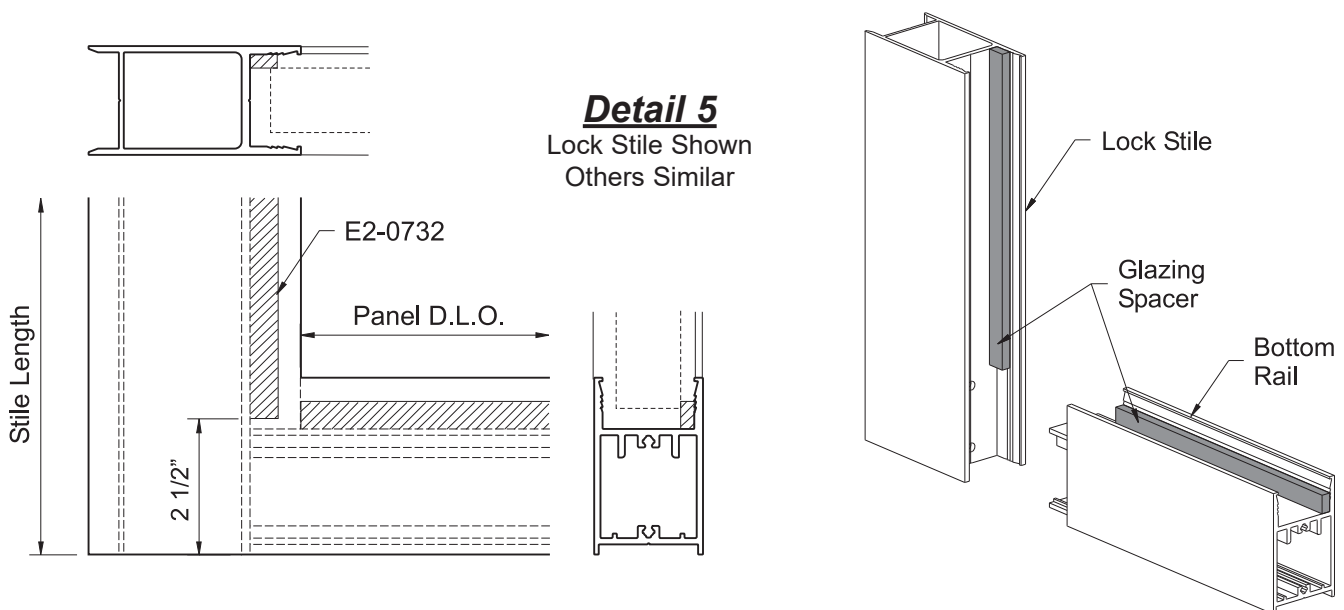

Large missile sliding panels also require the installation of side blocks, E2-0134 for lock stiles and meeting stiles, and E2-0178 for interlock stiles.

- Remove the protective backing from the side blocks, apply sealant to the backs of the blocks, and install them at the 1/4 points of the panel daylight opening as shown below.

See **Detail 6**.

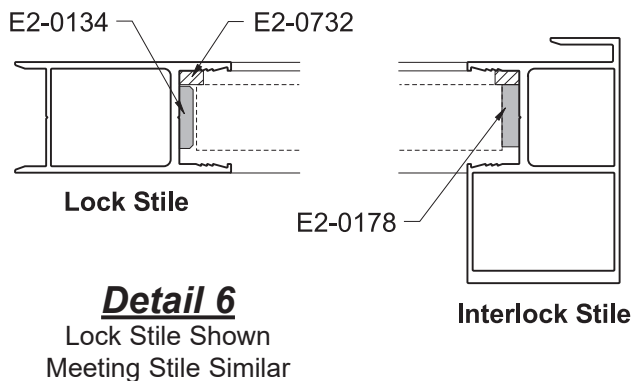

ASSEMBLE SLIDING PANELS

STEP 2 GLAZING SLIDING PANELS (FOR ALL PANELS)

-Just prior to assembling the panels, apply and tool sealant to the glass corners behind the gasket on both sides.

See **Detail 7**.

-Carefully lay the lite of glass down onto a pair of sawhorses.

-Apply sealant to the notched out ends of the top and bottom rails.

-Install setting blocks, E2-0177 for small missile or E2-0178 for large missile, along the bottom rail glazing pocket at 1/4 points or according to engineering calculations.

-Insert the top and bottom rails centered on the lite of glass with the exterior side of the panel facing up.

-Align the stiles (exterior sides facing up) with the rails and attach them using a rubber mallet. Make sure all glazing gaskets or spacers are properly aligned.

-Fasten each corner of the sliding panel with two PC-1220-SS fasteners.

-Tool and wipe away excess sealant at the joints.

-Install screw caps, K3-3004, into the clear holes at the top and bottom of the interlock stile.

Note: The middle hole at the bottom is left unplugged for adjustment of the rollers.

See **Detail 8**.

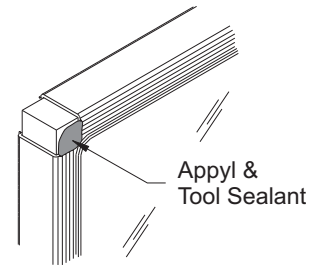

Detail 7

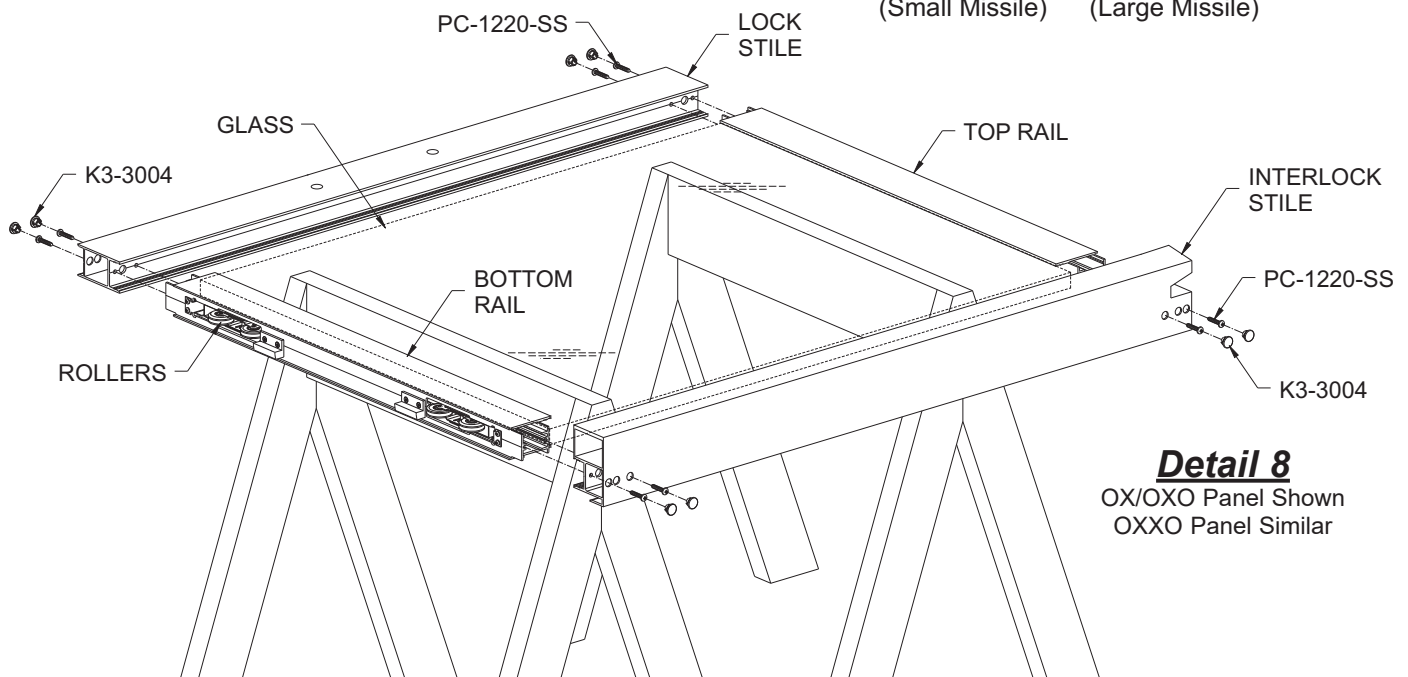
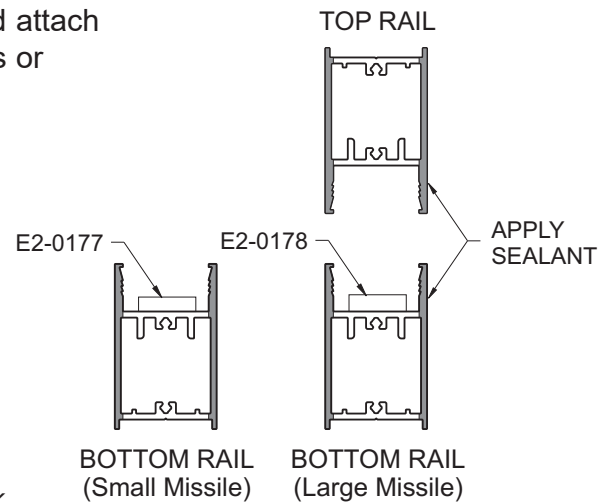

Detail 8
OX/OXO Panel Shown
OXXO Panel Similar

ASSEMBLE SLIDING PANELS

STEP 2 (Continued)

**FOR ALL SMALL MISSILE
& NON-IMPACT PANELS**

-Apply and tool sealant to the joint between the marine gasket and panel corners. Seal at each corner and on both sides of the panel.

See **Detail 9**.

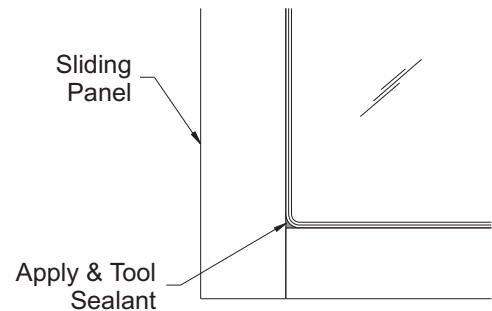

Detail 9

FOR ALL LARGE MISSILE PANELS

- Install exterior glazing gaskets.
- Cut horizontal & vertical glazing gaskets to Panel Daylight Opening plus (+) 1/4" for each foot of length.
- Install the vertical glazing gaskets first then the horizontal gaskets.
- Insert the gasket at each end. Then insert the gasket at the midpoint of the opening and push the remainder of gasket in working towards each end.

See **Detail 10**.

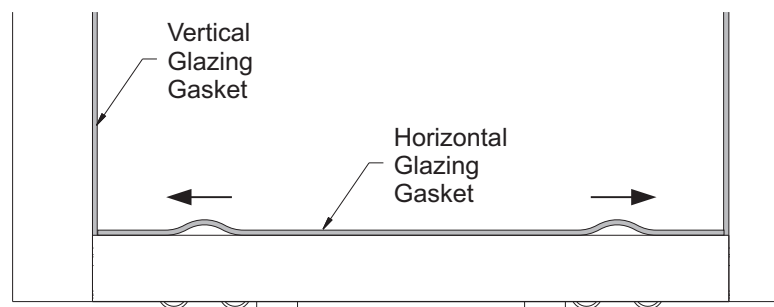

Detail 10

ASSEMBLE SLIDING PANELS

STEP 2 (Continued)

GLAZING SLIDING PANELS (FOR ALL LARGE MISSILE PANELS)

Apply Interior Structural Silicone Sealant:

- Carefully turn over the assembled sliding panel so that the interior of the panel is facing up. Rest the frame on the sawhorses allowing the weight of the glass to compress the push-in gaskets.
 - Make sure that all silicone contact surfaces and joints have been cleaned with isopropyl alcohol (50%) and lint free cloths using the “two cloth method.”
 - Apply masking tape to the aluminum and glass as shown.
 - Apply Dow Corning® 995 structural silicone sealant into the cavity between the panel and glass. Exert positive pressure so that the sealant completely fills the cavity.
 - Using a spatula or other non-scratching implement, immediately tool the sealant after running the joint. Exert positive pressure while tooling to ensure that the sealant makes positive contact with all surfaces.
- Be careful not to remove too much sealant!**
- Remove the masking tape within ten minutes of tooling.
- Do not allow the sealant to skin over!**

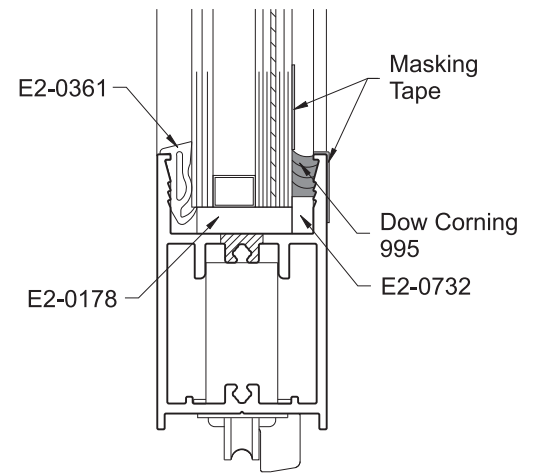

Detail 11

See **Detail 11**.

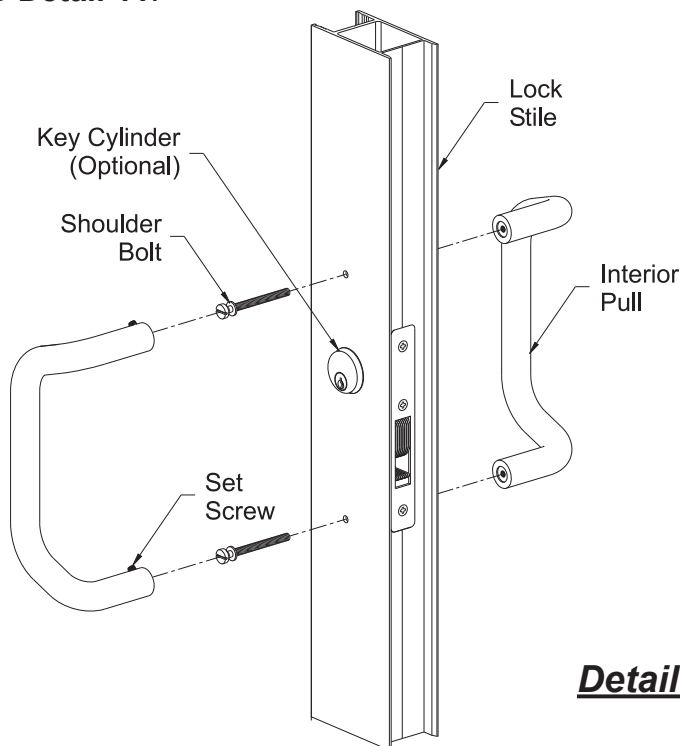

Detail 12

**STEP 3
ATTACH PULL HANDLES**

- Insert the shoulder bolts into the pre-drilled holes in the stile.
- Align the threaded holes at the ends the interior pull handle with the shoulder bolts and tighten the shoulder bolts.
- Insert the ends of the exterior pull handle over the shoulder bolt heads and tighten the set screws with an allen wrench.

See **Detail 12**.

ASSEMBLE SLIDING DOOR FRAME

STEP 4 ASSEMBLE SLIDING DOOR FRAMES

- Lay out members and locate fastener locations.
 - Apply and tool sealant to all exposed fastener ends for pre-attached parts at the head.
- See **Detail 13**.

Caution: To prevent the screw heads from shearing off, fasteners must be pre-driven into the screw splines and backed out before attaching the jamb and vertical members to the head and sill.

Warning: When required, insert steel channel E1-0195 into lock stile mullion E9-6106 and/or steel channel E1-0196 into interlock mullion E9-6105 prior to assembling the sliding door frames.

- Apply (butter) sealant to both ends of jamb and vertical members.
 - Attach the jamb and vertical members to the head and sill with PC-1220-SS fasteners as shown.
 - Tool and wipe away any excess sealant at the joints.
- See **Detail 14, 15 & 16**.

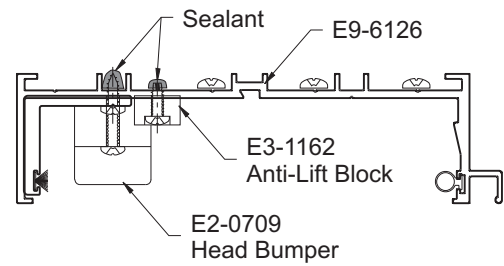
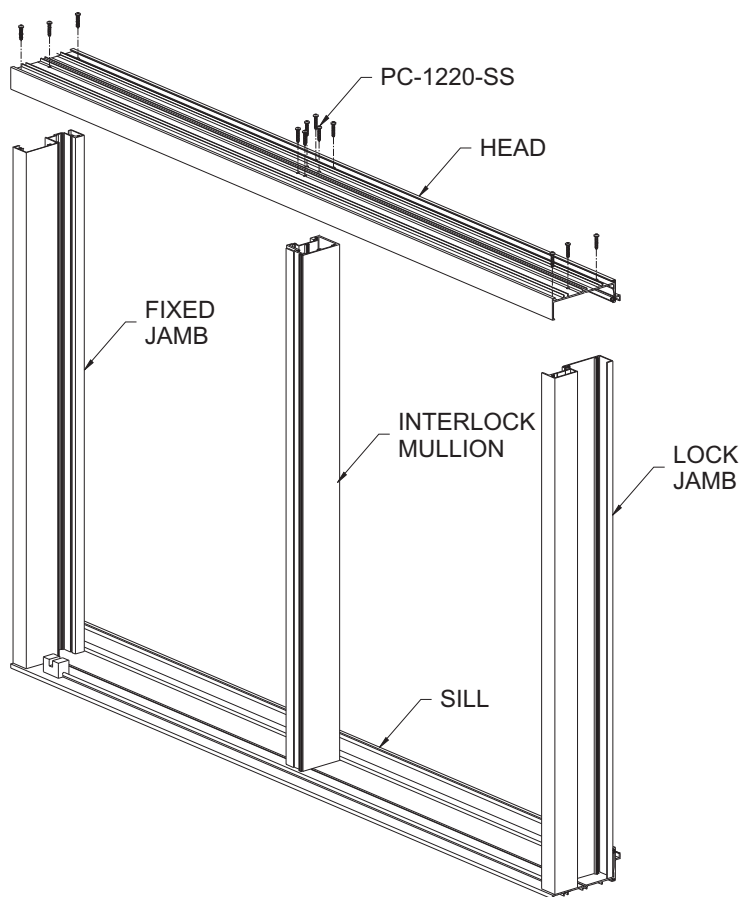

Detail 13

Detail 14
OX Frame

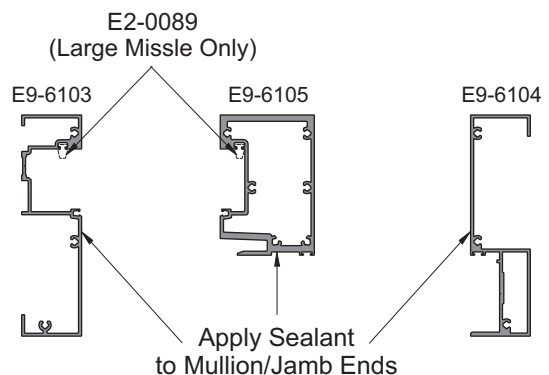

ASSEMBLE SLIDING DOOR FRAME

STEP 4 (Continued)
ASSEMBLE SLIDING DOOR FRAMES

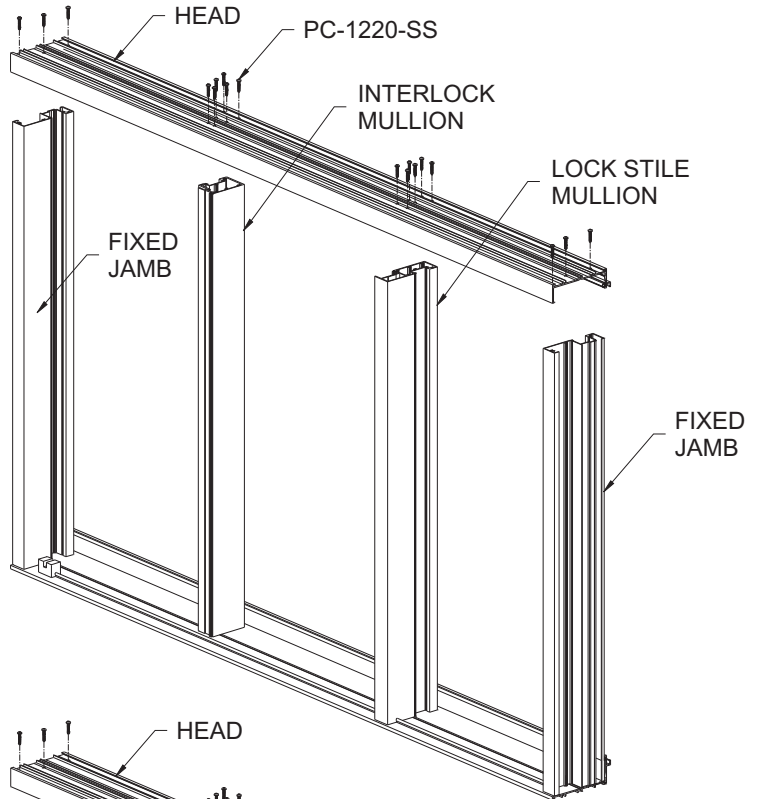

Detail 15
OXO Frame

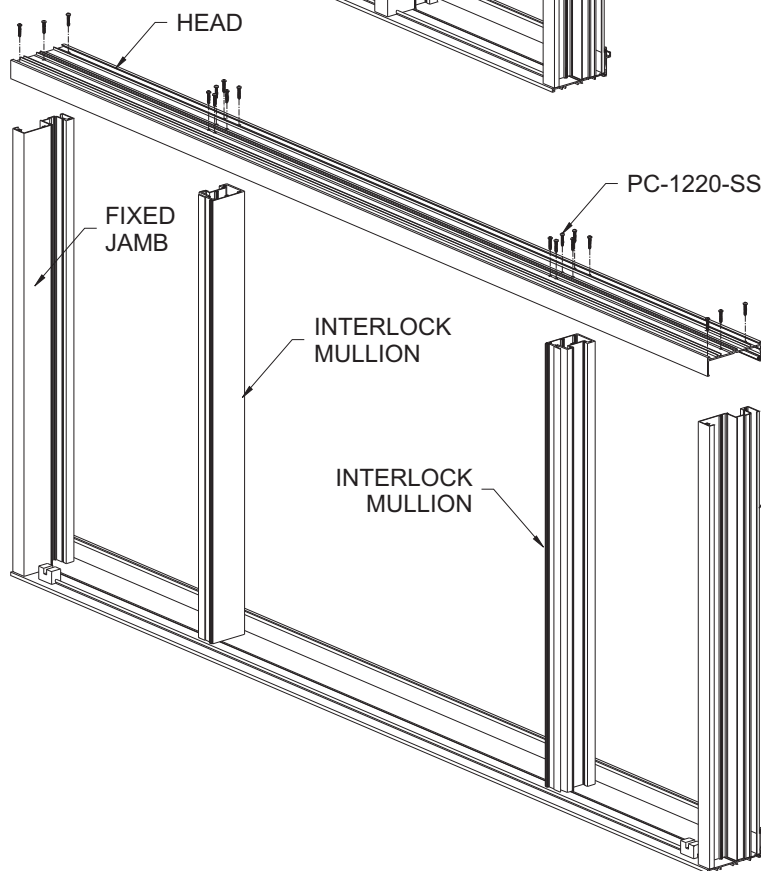
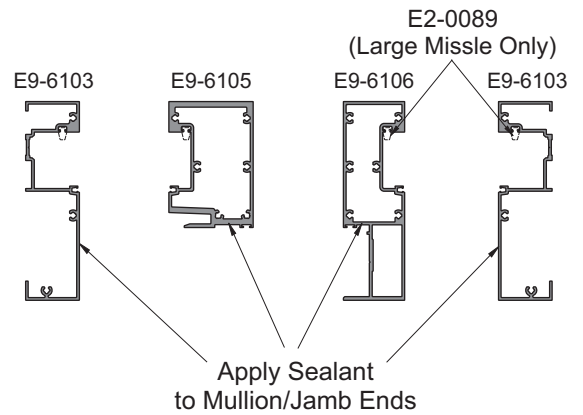

Detail 16
OXXO Frame

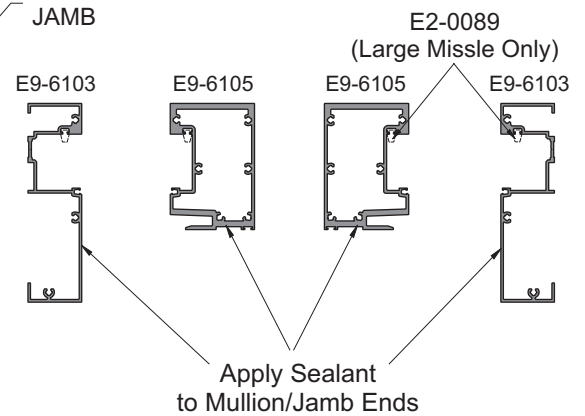

ASSEMBLE SLIDING DOOR FRAME

**STEP 5
PREP HEAD & SILL FILLERS**

-YSD 700 sliding door frames are anchored through the fixed panel head & sill fillers.

Drill appropriate size clearance holes for perimeter anchors in the head & sill fillers at locations shown on approved shop drawings.

-For Large Missile frames, cut interior glazing spacer, E2-0089, to the filler length and slide them into place. See **Detail 17**.

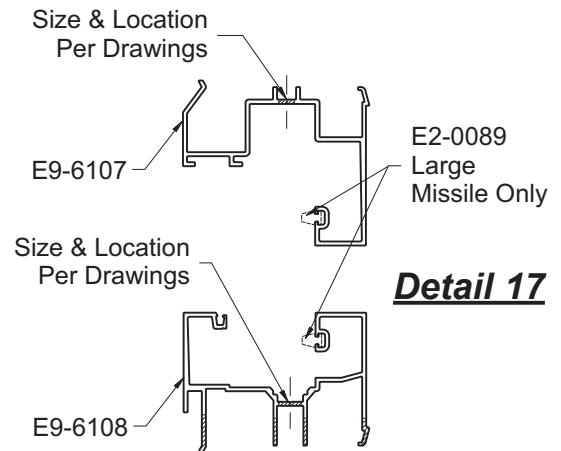

**STEP 6
ATTACH FIXED PANEL HEAD & SILL FILLERS**

-Just prior to attaching fixed panel head & sill fillers, apply and tool sealant to the sill filler reglet and back leg where the sill meets the jamb, interlock, and lock stile mullion. See **Detail 18**.

-Insert the front leg of the fixed panel head filler into the head filler reglet and rotate the head filler into place as shown below. Attach the fixed panel sill filler in a similar fashion. See **Detail 19**.

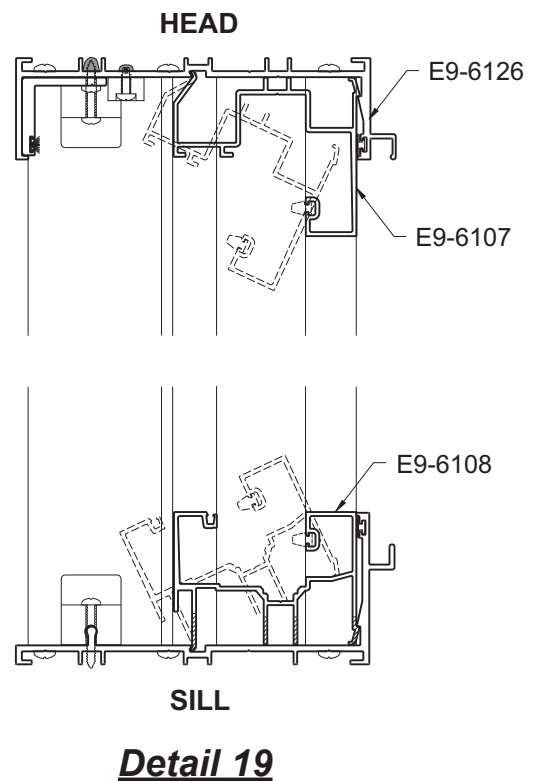
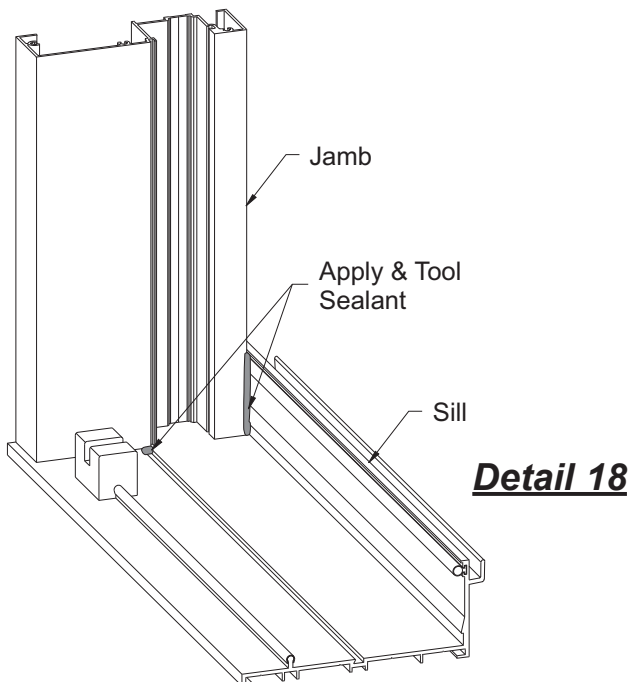

INSTALL SLIDING DOOR FRAME

**STEP 7
ANCHOR SLIDING DOOR FRAME**

-Check the rough opening for squareness and plumb at both ends. Also, make sure that appropriate space has been allowed for shim (3/8" minimum at the head and jambs, 1/8" nominal at the sill.)

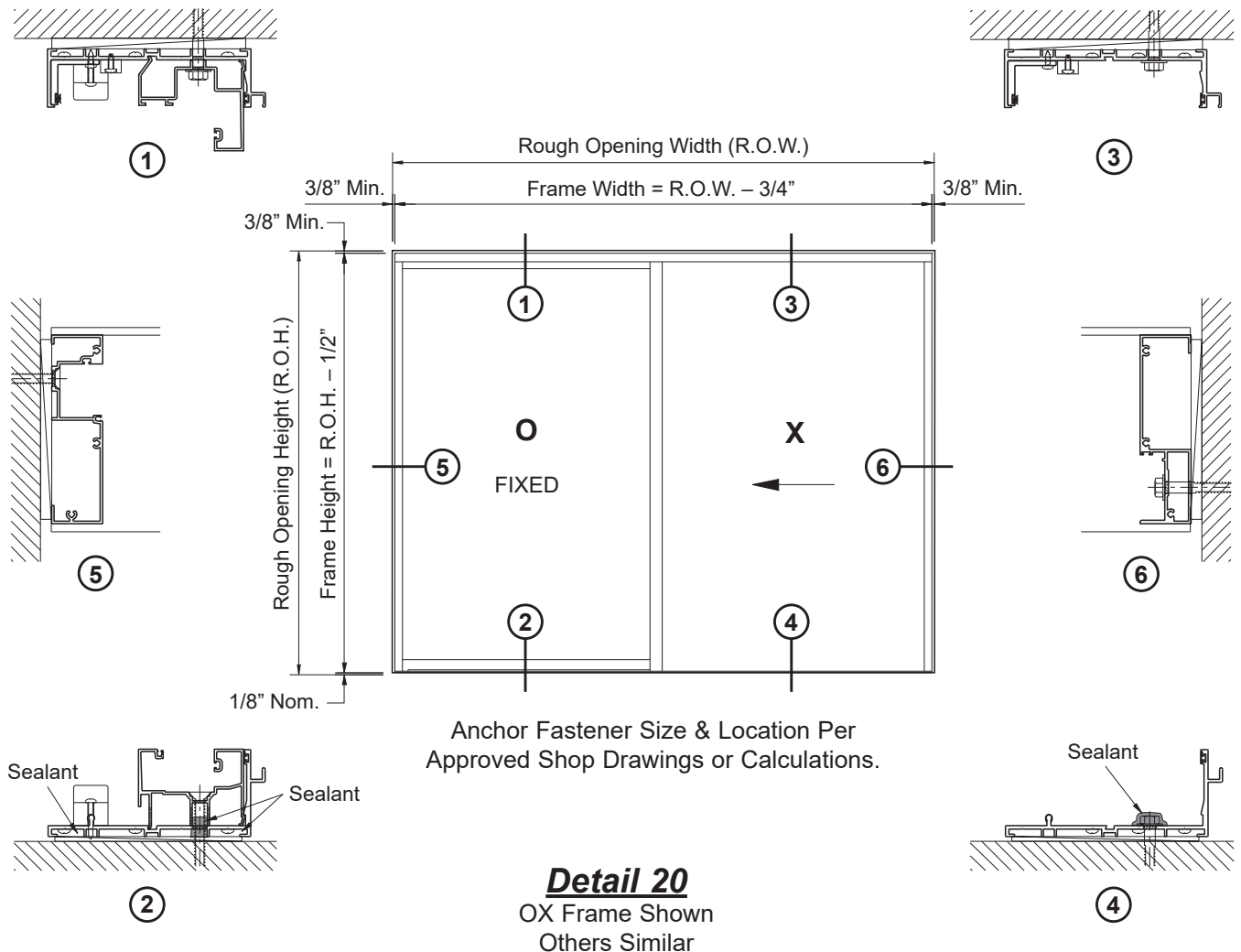

- Set the assembled frame in the prepared opening on a bed of sealant. The sill surface must be flat and level.
 - Temporarily attach the frame to the structure using clamps and/or rope.
 - Field drill the head, sill, and jambs for anchor fasteners according to approved shop drawings or engineering calculations. Consult YKK if load requirements are in question.
 - Make sure the sill is level and anchor it to the structure using appropriate anchor fasteners.
 - Seal all exposed anchor fastener heads at the sill on the sliding panel side.
- See **Detail 20**.

INSTALL SLIDING DOOR FRAME

STEP 7 (Continued)

ANCHOR SLIDING DOOR FRAME

-When anchoring through the fixed panel sill filler, E9-6108, squeeze a liberal amount of sealant through the clear holes just prior to installing the anchor fasteners to prevent water infiltration. See **Detail 21**.

-Shim the frame at the head and jambs as needed; the frame must be level, plumb, and true.
 -Install appropriate anchor fasteners at the head and jambs as shown in **Detail 20**.

Note: Shims must be installed at each anchor and run the full depth of the frame!

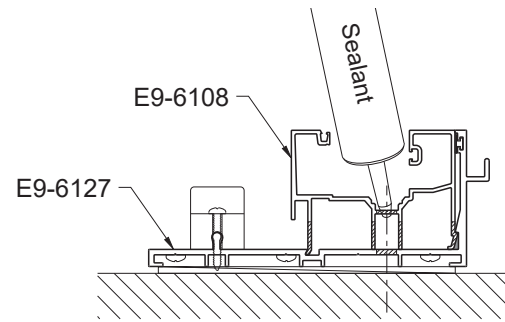

Detail 21

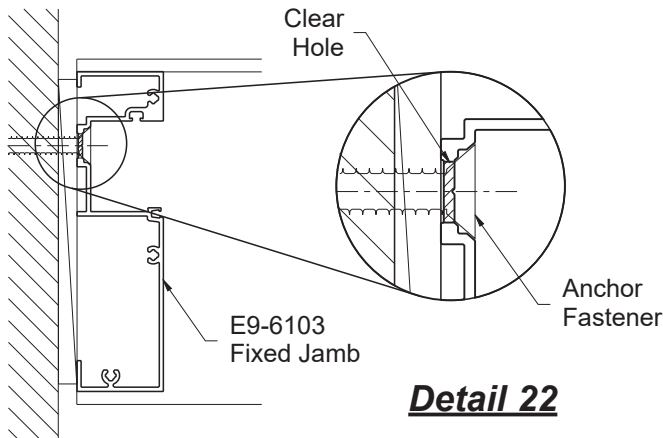
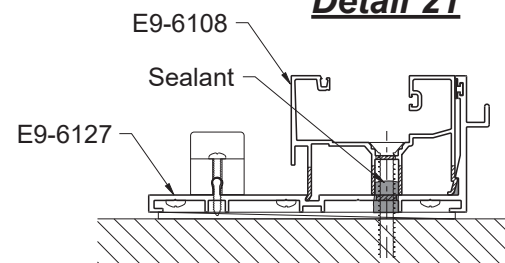

Detail 22

-Fixed jamb anchor clear holes must be drilled large enough to allow the flat head anchor fasteners to seat properly. Anchor heads that extend into the glazing pocket may cause glass breakage. See **Detail 22**.

For OXXO Configuration Only:

-Reinforcement angles, E1-1623, must be installed at the head and sill for OXXO frames.
 -Position the reinforcement angles in the head and sill reglets at the midpoint of the frame and match drill appropriate size clearance holes through the three pre-drilled holes in the angles into the head and sill.
 -Apply sealant around the holes previously drilled into the sill before installing anchor fasteners.
 -Install anchor fasteners through the reinforcement angles at the head and sill.
 -Seal the exposed anchor fastener heads at the sill. See **Detail 23**.

HEAD

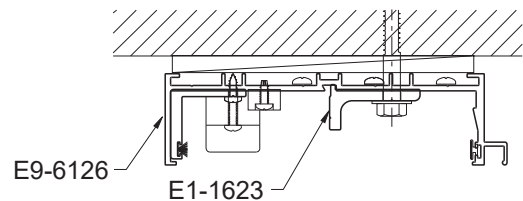

Detail 23

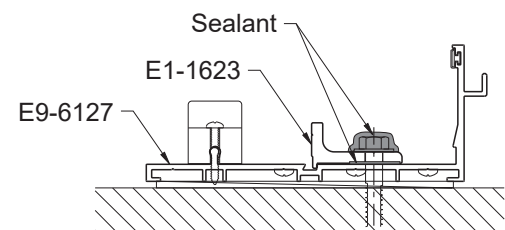

SILL

INSTALL SLIDING DOOR FRAME

STEP 8 APPLY PERIMETER SEALANT

- Install backer rod between the frame head and jambs and the structure.
- Apply masking tape to the frame where sealant is applied.
- Apply perimeter sealant at the head and jambs.
- Immediately tool the sealant to ensure watertight seal and remove the masking tape while the sealant is still wet.

- Apply a toe bead at the exterior of the sill and a heel bead at the interior.
- Tool the sealant to create a watertight seal.

Note: Perimeter sealant must be applied to both the exterior and interior of the frame.

See **Detail 24**.

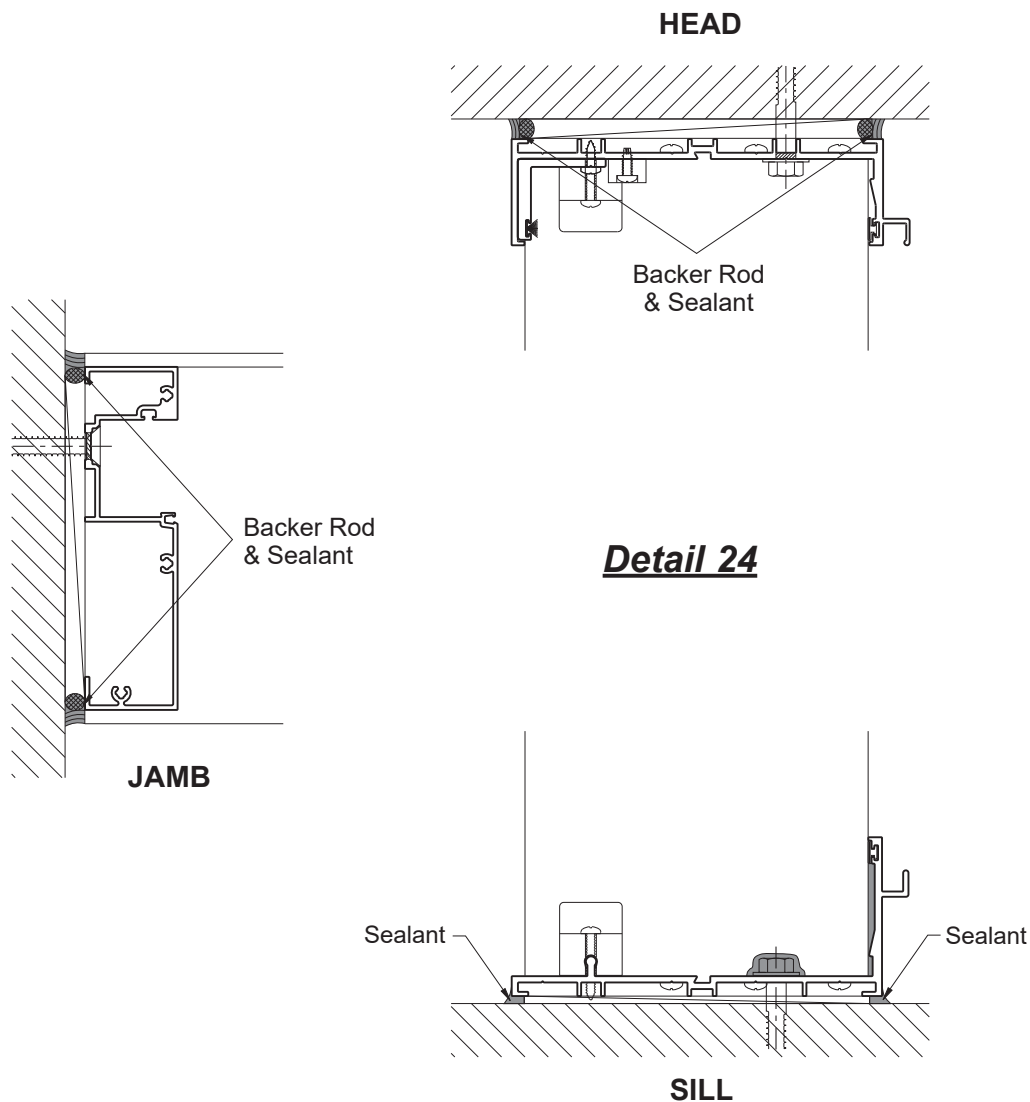

GLAZE FIXED PANELS

STEP 9 GLAZE FIXED PANELS

Install Interior Glazing Gaskets (For Non-Impact & Small Missile Frames Only):

- Cut vertical interior glazing gaskets, E2-0088, to the Daylight Opening (D.L.O.) plus(+) 2 1/2".
- Cut horizontal interior glazing gaskets, E2-0088, to the Daylight Opening (D.L.O.) plus(+) 3/16" per foot of opening width.
- Prior to installing the gaskets apply sealant to the intersection of the sill filler and the verticals.
- Tool sealant to ensure a watertight joint.
- Install the vertical interior glazing gaskets first.
 - Insert the gasket into the reglet at each end.
 - Push in the rest of the gasket starting from the middle and work towards each end.
- Then install the horizontal interior glazing gaskets.
 - Butter each end of the horizontal interior gasket with sealant.
 - Insert the gasket into the reglet at each end.
 - Push in the rest of the gasket starting from the middle and work towards each end. See **Detail 25**.
- Tool the excess sealant at the gasket intersection to ensure a watertight seal. Repeat at all intersections, interior, exterior, head and sill.

See **Detail 26**.

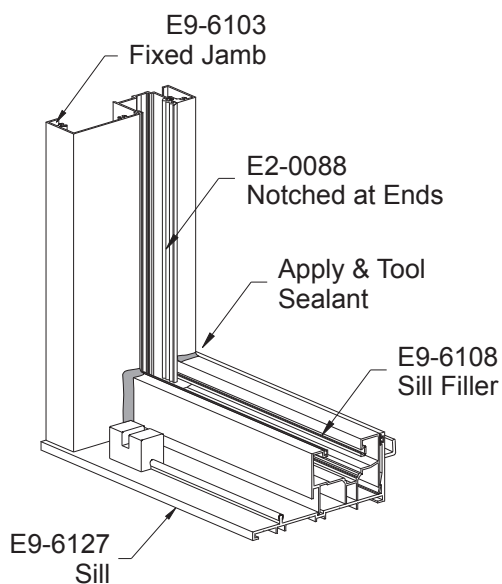

Detail 25

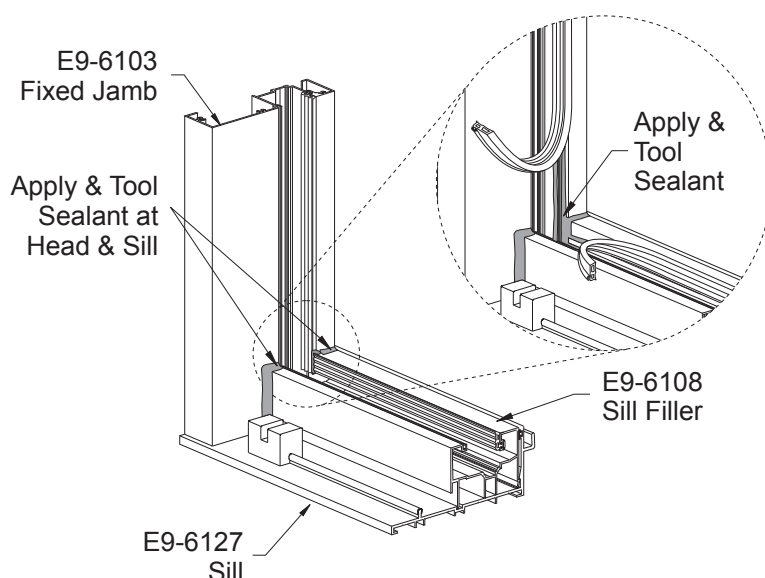

Detail 26

GLAZE FIXED PANELS

STEP 9 (Continued)

GLAZE FIXED PANELS (All Panels)

- Install setting blocks & setting block chairs along the sill at quarter points of daylight opening or according to engineering calculations. Setting blocks must be properly seated as shown below.
- Install side blocks at quarter points of daylight opening of the interlock mullion (E9-6105) and lock stile mullion (E9-6106) glazing pocket. Apply sealant to the back side of the side block and press it firmly against the glazing pocket.
- Carefully install glass into the frame making sure that the setting and side blocks are properly aligned with the glass. Impact resistant glass is **always** to the interior.
- Slide the glass into the deep jamb pocket and then slide over until contact is made with the side block in the shallow glazing pocket. This will ensure proper location and glass bite.

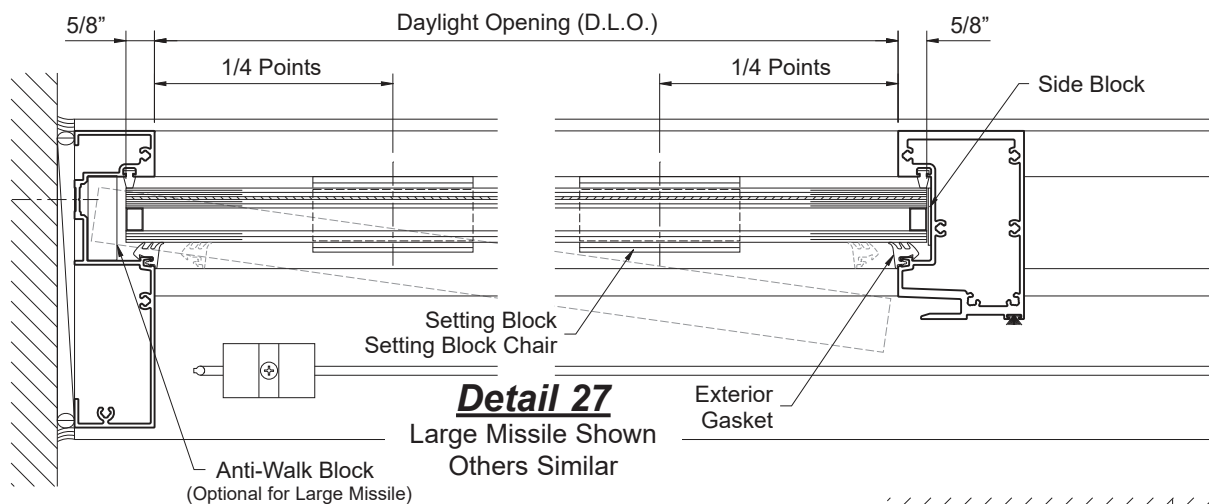

-For Dry Glazing only, install E2-0546 anti-walk block by inserting the block between the glass and the jamb. The anti-walk block must be inserted into the deep jamb pocket as shown in **Detail 27**.

-Install the head filler glass stops.

-Cut horizontal & vertical exterior glazing gaskets to the D.L.O. plus(+) 3/16" per foot of length.

- Install the vertical exterior glazing gaskets first.
 - Insert the gasket into the reglet at each end.
 - Push in the rest of the gasket starting from the middle and work towards each end.
- Then install the horizontal exterior glazing gaskets.
 - Insert the gasket into the reglet at each end.
 - Push in the rest of the gasket starting from the middle and work towards each end.

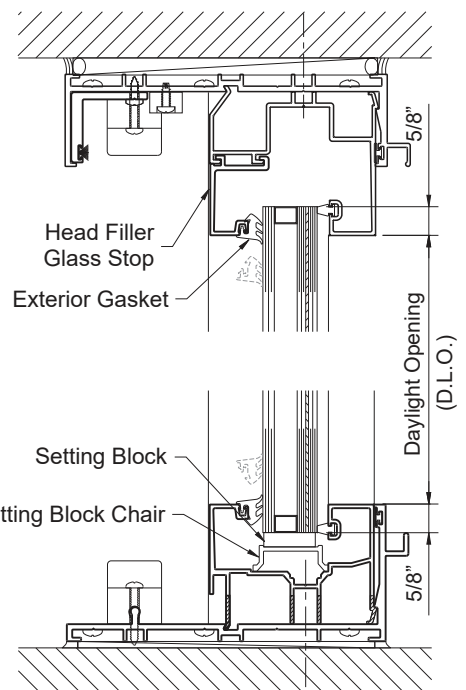

See **Details 27 & 28**.

Detail 28
Large Missile Shown
Others Similar

GLAZE FIXED PANELS

STEP 9 (Continued) GLAZE FIXED PANELS

Apply Interior Structural Silicone Sealant (For Large Missile Frames Only):

- Make sure that all silicone contact surfaces and joints have been cleaned with isopropyl alcohol (50%) and lint free cloths using the “two cloth method.”
- Apply masking tape to the aluminum and glass as shown below.
- Apply Dow Corning® 995 structural silicone sealant into the cavity between the aluminum and glass. Use positive pressure so that sealant completely fills the cavity.

Note: For vertical joints run the sealant from the bottom to the top of the joint.

- Using spatula or other non-scratching implement, tool the structural silicone sealant immediately after running the joint. Exert positive pressure while tooling to ensure that the silicone makes complete contact with all surfaces.

Note: Do not allow the sealant to skin over before it is tooled.
Be careful not to remove too much silicone.

- Immediately remove masking tape while wet; do not allow silicone to skin over.
Masking tape must be removed within 10 minutes of tooling.

See **Detail 29**.

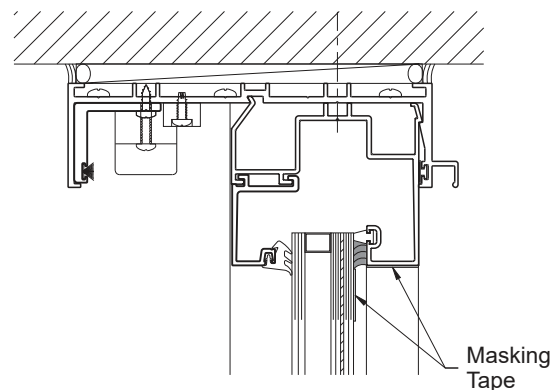
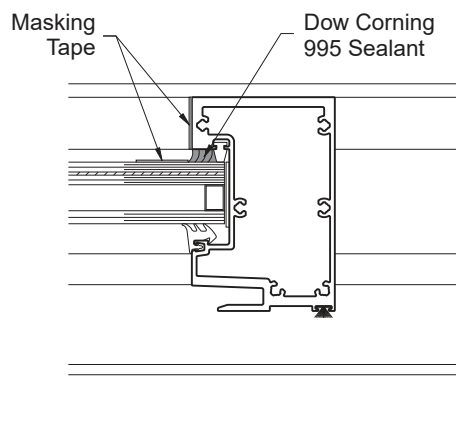

Detail 29

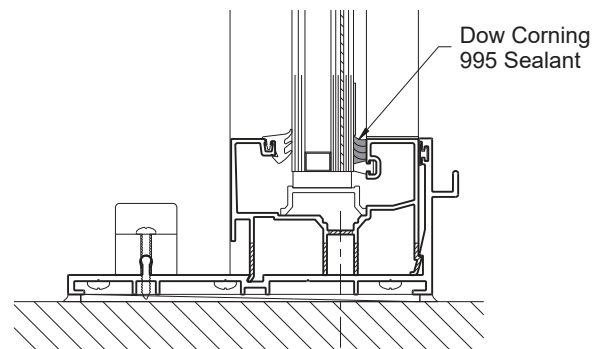

GLAZE FIXED PANELS

STEP 10 ATTACH SLIDING PANEL HEAD & SILL FILLERS

- Just prior to attaching sliding panel head & sill fillers, apply and tool sealant to the sill filler reglet and back leg where the sill meets the jamb and interlock or lock stile mullions.
- Insert the front leg of the sliding panel head filler into the head filler reglet and rotate the head filler into place as shown below. Install the sliding panel sill filler in similar fashion.

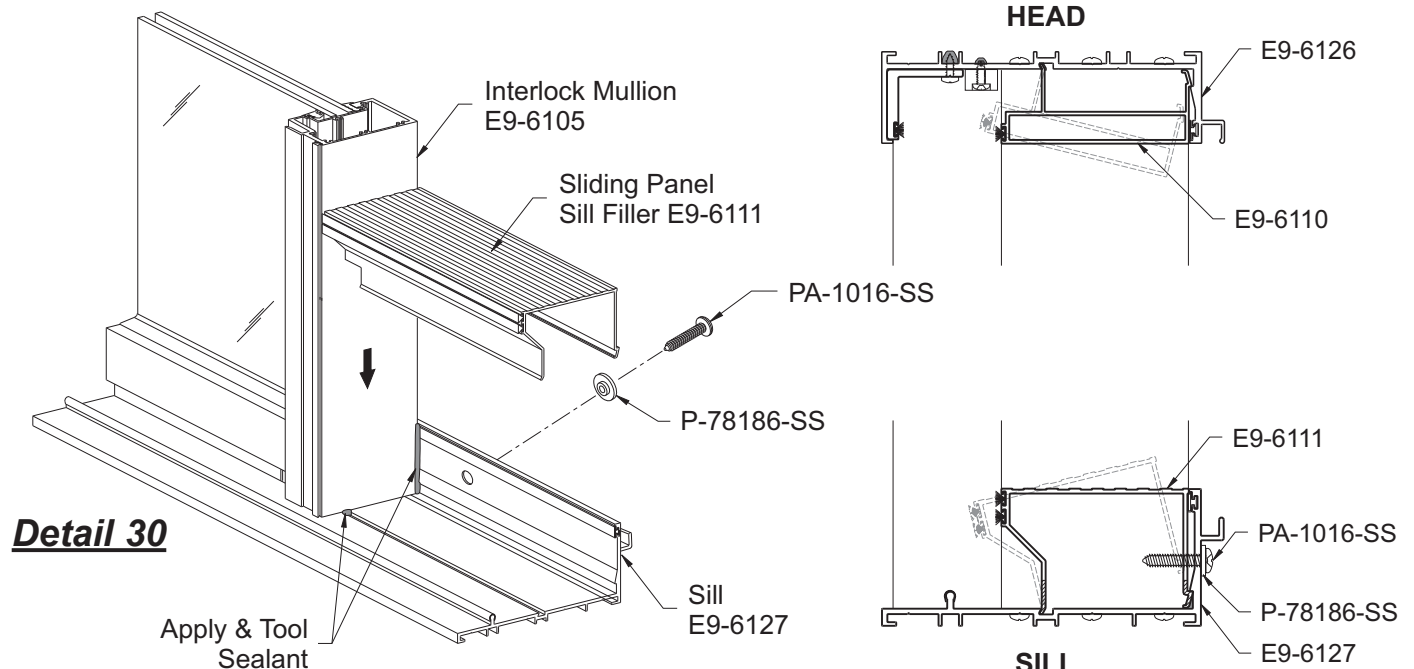

Note: Head and sill fillers must snap to ensure positive engagement. If the head and sill fillers are difficult to snap into place, puncture a pinhole into the head/sill bulb gasket to remove excess air.

-The E9-6127 sill contains predrilled clearance holes for fastening the E9-6111 sill filler to the E9-6127 sill. See **Detail 30**.

-Drill 5/32" diameter pilot holes on E9-6111 sill filler, thru the clearance holes that are located on the E9-6127 sill. After drilling the pilot holes on the sill filler, fill the holes with sealant. This sealant must reach the E9-6111 sill filler.

-Position P-78186-SS washer over hole with the neoprene side facing the sill, insert and tighten PA-1016-SS fastener. Remove excess sealant after tightening the PA-1016-SS fastener.

See **Detail 31**.

-Once the sill filler is installed apply and tool sealant to the joint where the sill filler meets the jamb and interlock or lock stile mullions.

-Also apply and tool sealant where the sill filler weatherstrip meets the mullion weatherstrip.

See **Detail 32**.

GLAZE FIXED PANELS

STEP 10 (Continued)

ATTACH SLIDING PANEL HEAD & SILL FILLERS

For OXXO Configuration Only:

- Just prior to attaching the sill filler, E9-6111, apply a bead of sealant across the length of the reinforcement angle, E1-1623, along the "V"-groove.
 - After the sill filler is in place match drill the reinforcement angle, E1-1623, with a 0.189" dia. (#12) bit through the pre-drilled holes in E9-6111.
 - Attach the sill filler to the reinforcement angle with PC-1210-SS fasteners.
- See **Detail 33**.

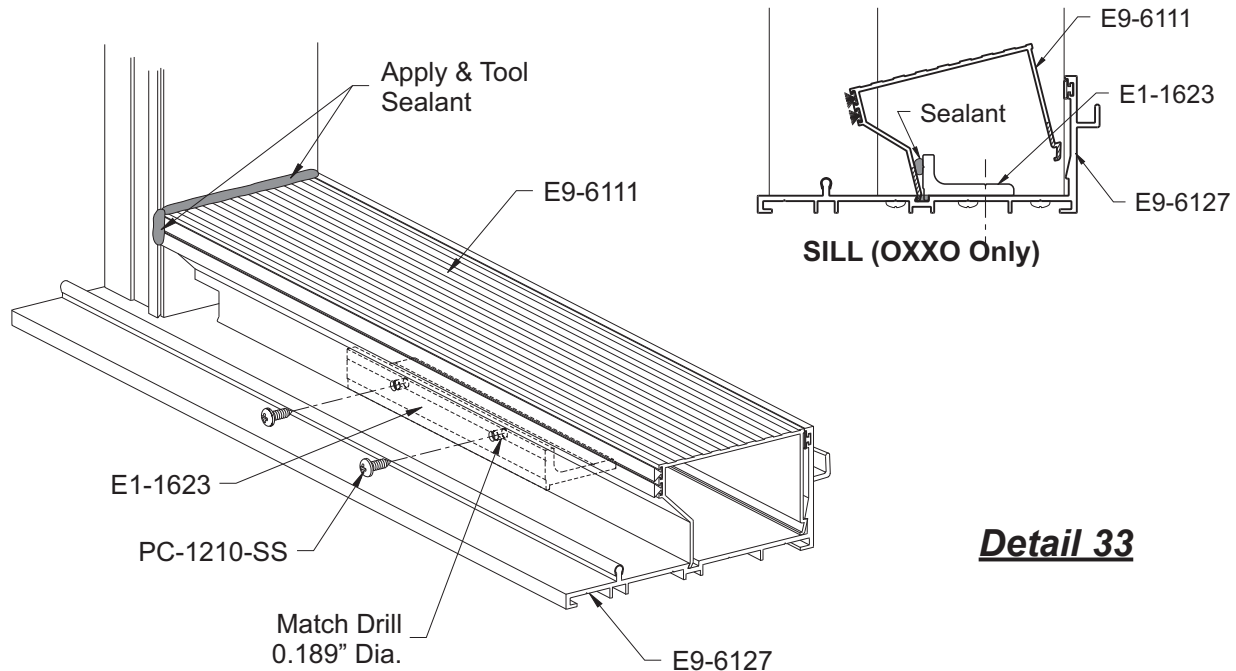

Detail 33

Note: The E9-6127 sill contains pre-drilled clearance holes for fastening the E9-6111 sill filler to the E9-6127 sill.

-Drill 5/32" diameter pilot holes on E9-6111 sill filler, thru the clearance holes that are located on the E9-6127 sill. After drilling the pilot holes on the sill filler, fill the holes with sealant. This sealant must reach the E9-6111 sill filler. See **Detail 30**.

-Position P-78186-SS washer over hole with the neoprene side facing the sill, insert and tighten PA-1016-SS fastener. Remove excess sealant after tightening the PA-1016-SS fastener. See **Detail 30**.

INSTALL SLIDING PANELS

STEP 11 INSTALL SLIDING PANELS

- Remove the one anti-lift block from the fixed side of the sliding door.
 - Lift the sliding panel(s) up into the frame on the fixed panel side in order to clear the anti-lift blocks.
 - Carefully lower the panel(s) down onto the roller track. Make sure that the rollers are properly aligned with the roller track.
 - Slide the sliding panel to the closed position and reinstall the anti-lift block previously removed.
- See **Details 34 & 35**.

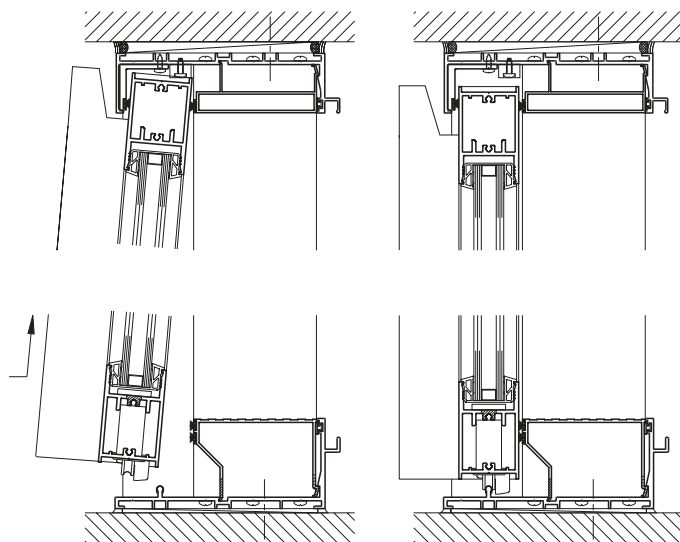

Detail 34

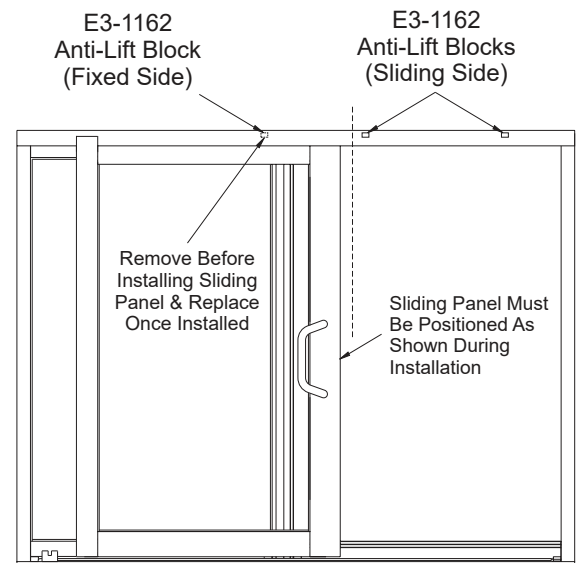

Detail 35

OX Shown
Others Similar

Caution: Do not allow the rollers to contact the floor before installing the sliding panels. Damage to the rollers may occur.

- The sliding panel should be aligned with the interlock mullion.
- Adjust the rollers of the sliding panel(s) through the access hole on each side as shown so that the door is level and rolls freely:
 - clockwise to raise panel.
 - counterclockwise to lower panel.

See **Detail 36**.

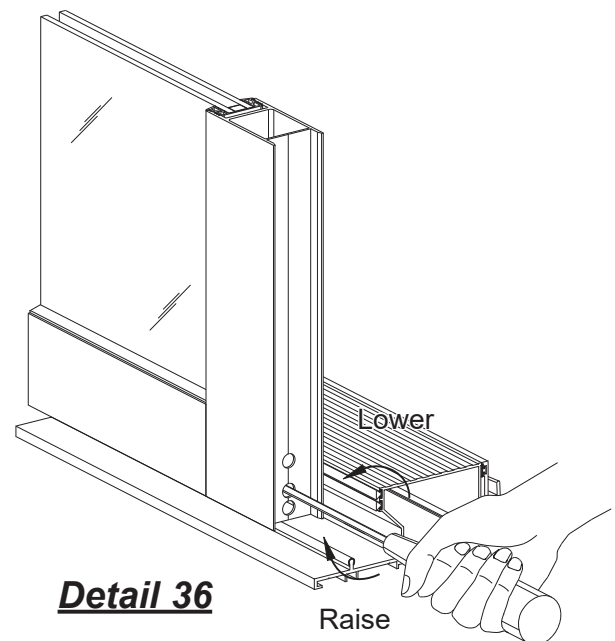

Detail 36

CALCULATING GLASS SIZES

CONFIGURATION	GLASS WIDTH*
OX / XO	$(FW - 7 \frac{1}{8}'') / 2$
OXO	$(FW - 7 \frac{7}{8}'') / 3$
OXXO	$(FW - 11 \frac{1}{2}'') / 4$

PANEL TYPE	GLASS HEIGHT
FIXED	$(FH - 5 \frac{1}{4}'')$
SLIDING	$(FH - 7 \frac{3}{8}'')$

* Intermediate frame is not located at the center of the frame width, but where it would make for equal daylight openings.

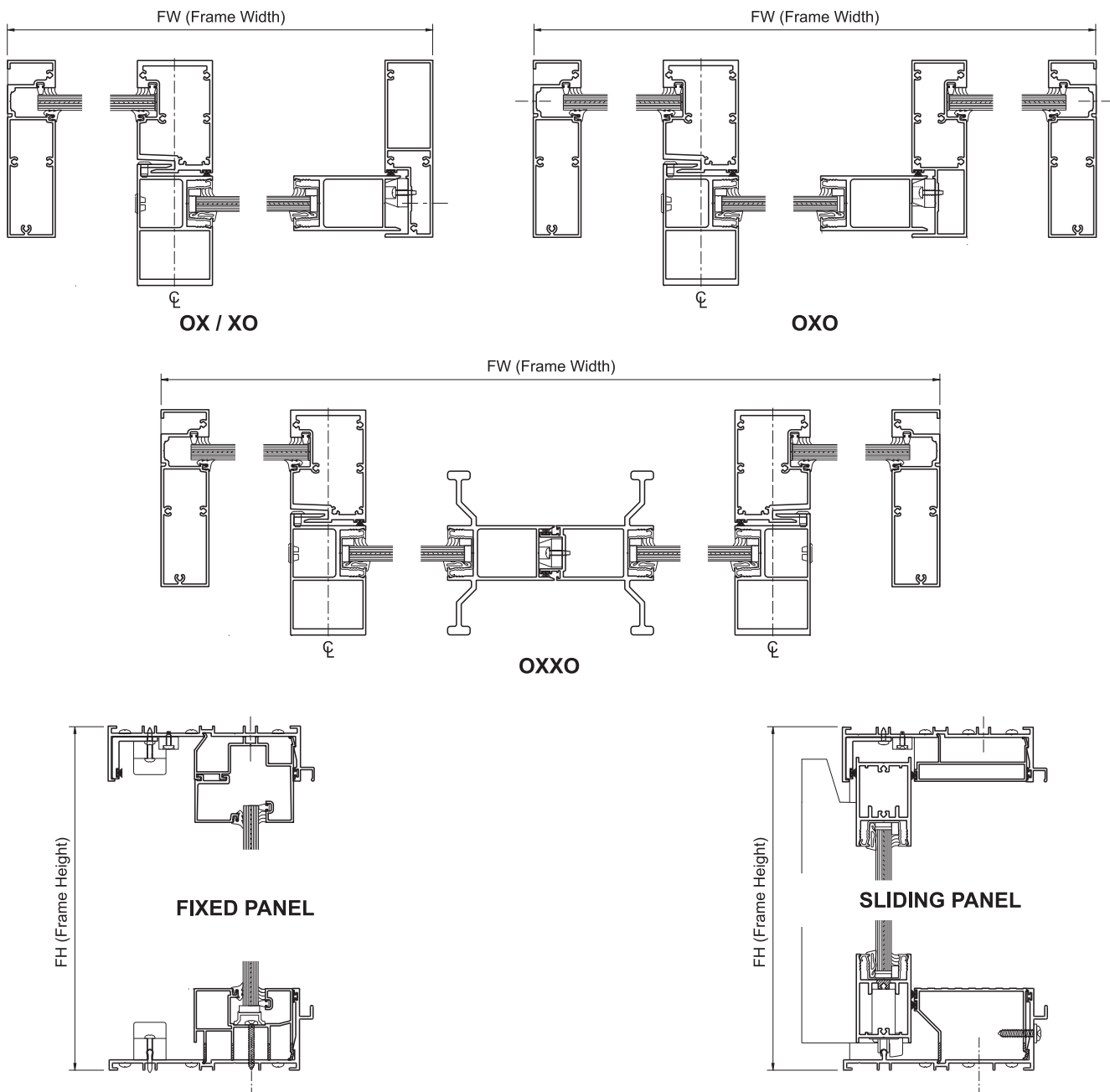



101 Marietta Street NW
Suite 2100
Atlanta, Georgia 30303
www.ykkap.com