

YUW 750 XT Unitized Curtain Wall System

4 Side SSG

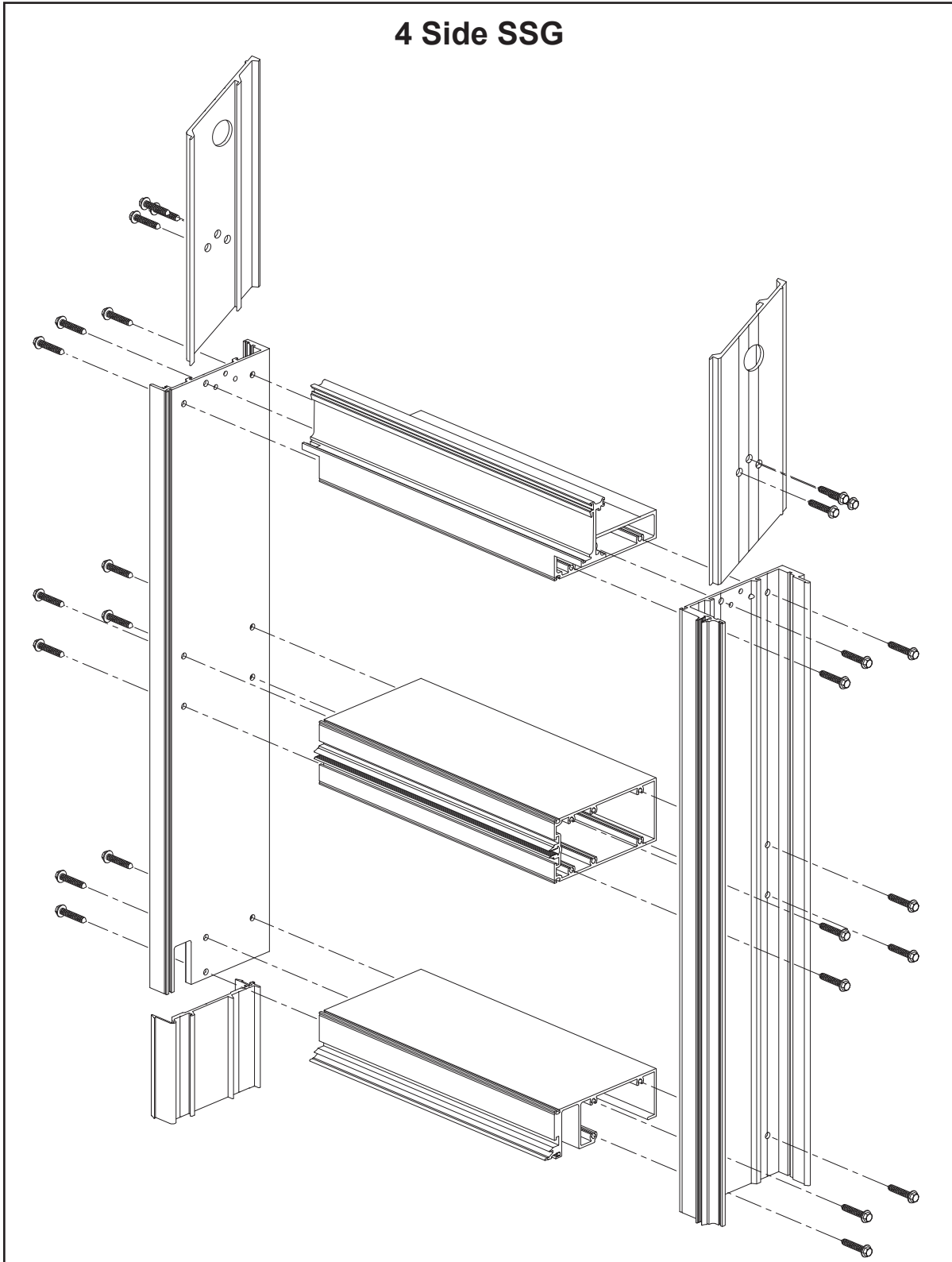

Assembly Manual

INTRODUCTION

YKK AP Fabrication, Assembly, and Installation manuals for Unitized Wall Systems are organized in to three specific manuals. The focus of this manual is the assembly and glazing of the fabricated parts.

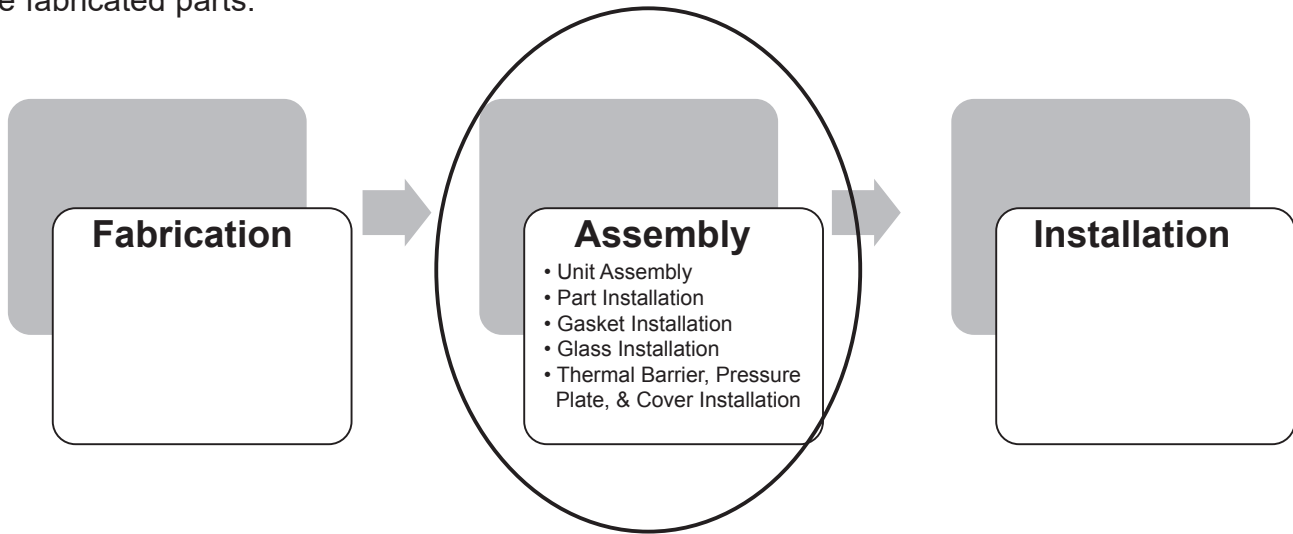

The assembly manual from the YKK AP YUW 750 XT Unitized Curtain Wall System is designed and organized to directly connect with the fabrication manual supplied by YKK AP and the example elevation below.

The assembly manual is broken out by unit in the appropriate sequence. This assembly manual illustrates units with 1” insulating glass. Other infills will require optional framing members and accessories. Installation of the collective units is covered in the installation manual.

This manual was designed to take you through each unit of the **example elevation**. It is a step-by-step reference for unit assembly.

Not all projects are the same and your project may differ from the example elevation. Please refer to your specific project plan to ensure contents are relevant to your project.

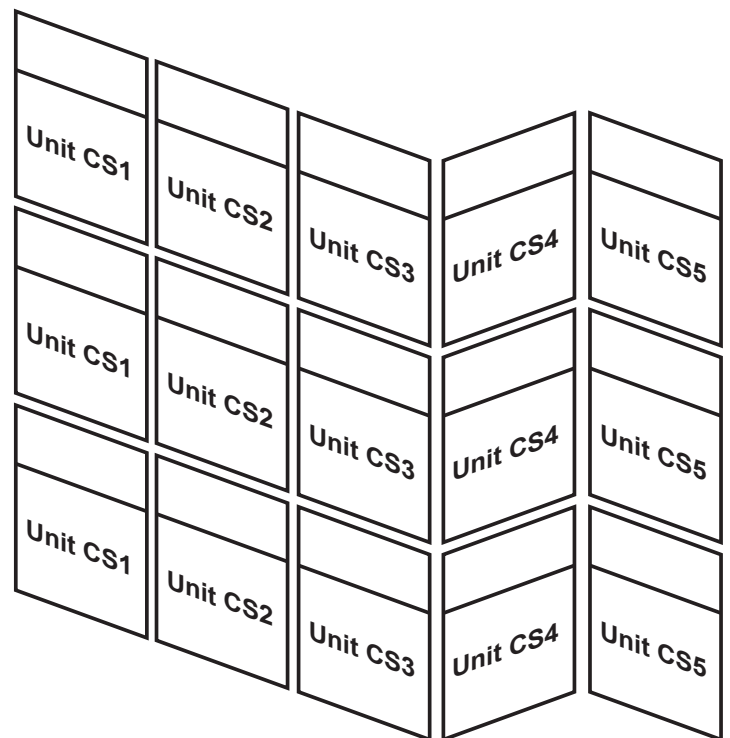

If you have any additional questions or need assistance, please contact YKK AP Engineering Center for more information.

Installation Notes

1. Do not drop, roll or drag boxes of aluminum framing. Move and stack boxes with proper support to prevent distortion. If fork lifts are used, be especially careful about striking the boxes when lifting or moving.
2. Store in a dry, out of the way area. If rain exposure, condensation or any water contact is likely, then all packaging material should be removed. Wet packaging materials will discolor and may stain aluminum finishes and paints.
3. All materials should be checked for quality and quantity upon receipt, YKK AP must be notified immediately of any discrepancies in shipment. Check to make sure that you have the required shims, sealants, supplies and tools necessary for the installation.
4. Carefully check the openings and surrounding conditions that will receive your material. Remember, if the construction is not per the construction documents, it is your responsibility to notify the general contractor in writing. Any discrepancies must be brought to the general contractor's attention before you proceed with the installation.
5. Gather your shop drawings, materials, packing list, and this installation manual. Carefully review parts location, the sequence it goes therein, when you glaze it and how you seal it. Installation instructions are of a general nature and may not cover every condition you will encounter. The shop drawings and/or installation manuals were prepared specifically for the product.
6. Any material substitutions must be of equal or greater quality.
7. Make certain that material samples have been sent for compatibility testing for all manufacturer's sealants involved. Make certain sealants have been installed in strict accordance with the manufacturer's recommendations and specifications.
8. Remember to isolate, in an approved manner, all aluminum from uncured masonry or other incompatible materials.
9. System-to-structure fasteners are not supplied by YKK AP. Fasteners called out on shop drawings are to indicate minimum sizes for design loading.
10. If any questions arise concerning YKK AP products or their installation, contact YKK AP for clarification before proceeding.
11. YKK AP storefront and/or curtain wall framing is typically completed before drywall, flooring and other products which may still be in process. Take the extra time to wrap and protect the work produced.
12. Cutting tolerances are plus zero, minus one thirty second unless otherwise noted.
13. Check our website, www.ykkap.com, for the latest installation manual update prior to commencing work.

Important Notice for SSG Curtain Wall Systems:

In order to properly perform and to maintain structural integrity, in addition to all other installation requirements, structurally glazed curtain wall systems rely specifically upon effective and appropriate structural sealant selection and installation.

It is the responsibility of the glazing contractor to take all steps to ensure the installed structural sealant is capable of meeting all applicable project requirements in accordance with industry standards. Such steps on each project may include, but are not limited to, design reviews, formal adhesion testing, project specification compliance, validating applications, field testing, auditing, sealant design strength analysis, and the quality control review of the installation and surrounding conditions.











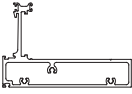
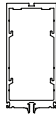

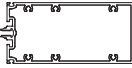
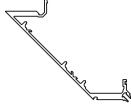



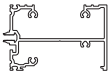

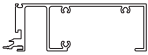
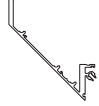
Subject to project specific design pressures, requirements, and/or specifications, the structural sealant that is used between the glass and framing system must be capable of withstanding tensile and shear stresses imposed by the curtain wall without failing adhesively or cohesively.

The structural sealant's capability to withstand these stresses are dependent on several factors including, but not limited to, type of structural sealant, method of application (i.e. cleaning, primer), construction of glazing material (i.e. insulating glass unit (IGU), other infill, and finish of framing (i.e. anodizing, paint).

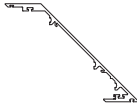

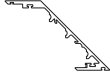







- Adhesive failure occurs when sealant pulls away from substrate cleanly, leaving no sealant material behind.
- Cohesive failure occurs when sealant breaks or tears within itself but does not separate from each substrate because sealant-to-substrate bond strength exceeds sealant's internal strength.

The IGU and/or other infill must be constructed for installation into structurally sealant glazed curtain walls. Notify the manufacturer or fabricator of the IGU and/or infill and advise of the product's application into 2 or 4-sided structurally sealant glazed curtain walls along with the project's design requirements so that appropriate fabrication steps are taken.











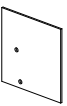

FRAMING MEMBERS

	Stacking Tray For 7-1/2" System	E9-7027		Jamb Mullion For 7-1/2" System	E9-7098
	Stacking Tray For 6" System	E9-7037		Jamb Mullion For 6" System	E9-7063
	Intermediate Horizontal For 7-1/2" System	E9-7097		90° Outside Corner Male Mullion For 7-1/2" System	E9-7045
	Intermediate Horizontal For 6" System	E9-7064		90° Outside Corner Male Mullion For 6" System	E9-7068
	Open Back Head/Sill For 7-1/2" System	E9-7099		90° Outside Corner Female Mullion For 7-1/2" System	E9-7046
	Open Back Head/Sill For 6" System	E9-7065		90° Outside Corner Female Mullion For 6" System	E9-7069
	SSG Stacking Sill For 7-1/2" System	E9-7023		90° Inside Corner Male Mullion For 7-1/2" System	E9-7047
	SSG Stacking Sill For 6" System	E9-7078		90° Inside Corner Male Mullion For 6" System	E9-7070
	Male Mullion For 7-1/2" System	E9-7095		90° Inside Corner Female Mullion For 7-1/2" System	E9-7048
	Male Mullion For 6" System	E9-7061		90° Inside Corner Female Mullion For 6" System	E9-7071
	Female Mullion For 7-1/2" System	E9-7002		Starter Sill	E9-7094
	Female Mullion For 6" System	E9-7062		SSG Jamb Spacer For 1-5/16" Glazing	E9-4597



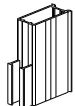







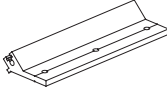
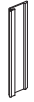
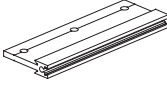

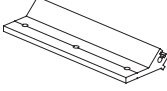

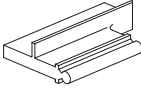
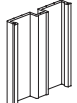
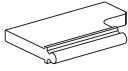

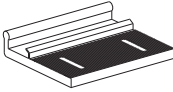

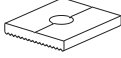

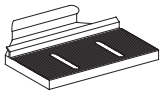
FRAMING MEMBERS

	SSG Jamb Adaptor Base	E9-7052		Mullion Interlocking Clip For 6" System	E9-7072
	SSG Jamb Adaptor	E9-7053		1/4" Adaptor For 1-5/16" Glazing	E9-7749
	Flush Filler Use with E9-7043	E9-7044		Face Cover (Optional)	E9-1206
	Flush Filler Use with E9-7065	E9-7066		Pressure Plate (Optional) For 1" Glazing	AS-7054
	Mullion Interlocking Clip For 7-1/2" System	E9-7003		Pressure Plate (Optional) For 1-5/16" Glazing	AS-7057



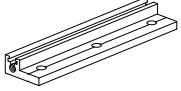

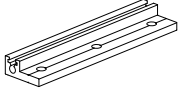





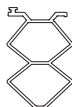











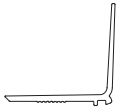

ACCESSORIES

	Stack Joint Plate	E1-7001		Mullion Sleeve Right Hand For 7-1/2" System	E1-7021
	End Dam	E1-7002		Mullion Sleeve Left Hand For 7-1/2" System	E1-7022
	Mullion Clip Use with E9-7002	E1-7003		Mullion Sleeve Right Hand For 6" System	E1-7075
	Mullion Clip Use with E9-7062	E1-7072		Mullion Sleeve Left Hand For 6" System	E1-7076
	Mullion Anchor Sleeve	E1-7006		Mullion Reinforcement Clip For 6" System	E1-7046
	Mullion Reinforcement Clip For 7-1/2" System	E1-7007		Corner Mullion Sleeve Right Hand For 7-1/2" System	E1-7048

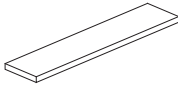

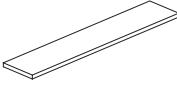





ACCESSORIES

	Corner Mullion Sleeve Left Hand For 7-1/2" System	E1-7049		90° I.S. Corner Leveling Anchor (LH)	E1-7033
	Corner Mullion Clip Use with E9-7046 & E9-7069	E1-7050		90° O.S. Corner Leveling Anchor	E1-7032
	Corner Mullion Sleeve Right Hand For 6" System	E1-7079		90° I.S. Corner Leveling Anchor (RH)	E1-7034
	Corner Mullion Sleeve Left Hand For 6" System	E1-7080		Bracket Sleeve	E1-7092
	Corner Mullion Reinforcement Clip	E1-7051		Bracket Sleeve	E1-3906
	Mullion Anchor For 6" System	E1-7004		L Anchor	E1-3907
	Jamb Anchor For 6" System	E1-7005		Lock Washer	E1-3908
	Mullion Anchor For 7-1/2" System	E1-7024		90° L Anchor For 90° Outside Corner	E1-3917
	Jamb Anchor For 7-1/2" System	E1-7025		SSG Setting Block Chair For 1" Glass	E1-7067
	90° I.S. Corner Anchor	E1-7028		SSG Setting Block Chair For 1-5/16" Glass	E1-7011
	90° O.S. Corner Anchor	E1-7029		90° Corner Starter Sill Splice	E1-7027
	Leveling Anchor Right Hand	E1-7014		Jamb Stack Block	E1-7081
	Leveling Anchor Left Hand	E1-7015		Silicone Splice Sleeve	E2-0070

ACCESSORIES

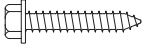
	3/4" Spacer Sponge	E2-0725		Sill Horizontal Weather Seal	E2-7016
	Stacking Tray Spacer	E2-3906		SSG Thermal Barrier For 1" Glazing	E3-7013
	Interior Gasket	E2-7001		SSG Thermal Barrier For 1-5/16" Glazing	E3-7011
	Glazing Spacer Tape	E2-0110		SSG Corner Thermal Barrier For 1-5/16" Glazing	E3-7020
	SSG Corner Spacer	E2-7014		I.G.U. Cap For 1" Glazing	E3-7002
	Air Water Seal Gasket	E2-7002		I.G.U. Cap For 1-5/16" Glazing	E3-7018
	Stacking Tray Gasket	E2-7004		Sill Track Adaptor	E3-7023
	Exterior Gasket	E2-7005		Pocket Filler For 1" Glazing	E3-7008
	SSG Wiper Gasket	E2-7009		Pocket Filler For 1-5/16" Glazing	E3-7015
	SSG Corner Wiper Gasket	E2-7015		Thermal Barrier	E3-7017
	SSG Setting Block For 1" Glazing	E2-7011		Thermal Shield For 1" Glazing	E3-7003
	SSG Setting Block For 1-5/16" Glazing	E2-7017		Thermal Shield For 1-5/16" Glazing	E3-7016
	Weather Seal Gasket	E2-7010		End Cap	E3-7024

ACCESSORIES

 <p>#10 x 5/8" FHMS Type AB, Zinc Plated Steel</p>	<p>FC-1010</p>	 <p>#10 x 5/8" PHSMS Type AB, Stainless Steel For Attachment of End Dam to Sill Starter</p>	<p>PC-1010-SS</p>
 <p>1/4"-20 x 1-1/4" HWHS Type CA, Zinc Plated Steel</p>	<p>HD-2520-W3</p>	 <p>1/2"-13 x 1/2" Set Screw Zinc Plated Steel For Leveling Bracket</p>	<p>YM-5008</p>
 <p>#12 x 1-1/4" HWHS Stainless Steel, For Screw Spline Attachment</p>	<p>HC-1220-SS</p>	 <p>#10-24 x 1/2" FHUCMS Stainless Steel, For Attachment of End Cap to Vertical Mullion</p>	<p>UF-1008-SS</p>
 <p>#12 x 1-3/4" HWHSMS Stainless Steel, For Screw Spline Attachment at Corner</p>	<p>HC-1228-SS</p>	 <p>#10 x 1/2" PHSMS TYPE AB, Stainless Steel, For Attachment of Angle to Jamb</p>	<p>PC-1008-SS</p>
 <p>1/4"-20x2" HHMS Stainless Steel, For Pressure Plate Attachment</p>	<p>HM-2532-SS</p>		

CS1 TABLE OF CONTENTS

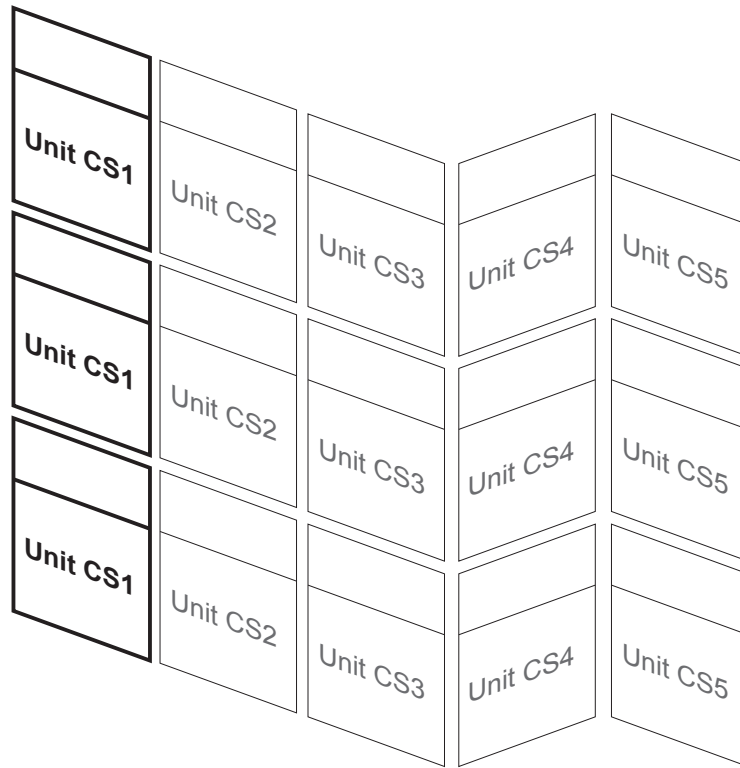

The following is intended for use as a guide for assembly of **Unit CS1** of the **YUW 750 XT 4-Sided SSG Curtain Wall System**. It is organized into five steps which will take you from assembly of parts to completed units.

Step 1: CS1 Unit Assembly	Pages 2 to 6
Step 2: CS1 Parts Installation	Pages 7 to 9
Step 3: CS1 Gasket Installation	Pages 10 to 12
Step 4: CS1 Glass Installation	Pages 13 to 17
Step 5: CS1 Thermal Barrier & Weatherseal Installation.....	Pages 18 to 21

Care should be taken to ensure you have inventory of all items required to complete this assembly. We recommend you refer to the parts list (pages iv - viii) as a reference and compare it to your specific project to ensure you have all the correct parts and tools required to complete the assembly.

STEP 1: CS1 UNIT ASSEMBLY

MAJOR COMPONENTS

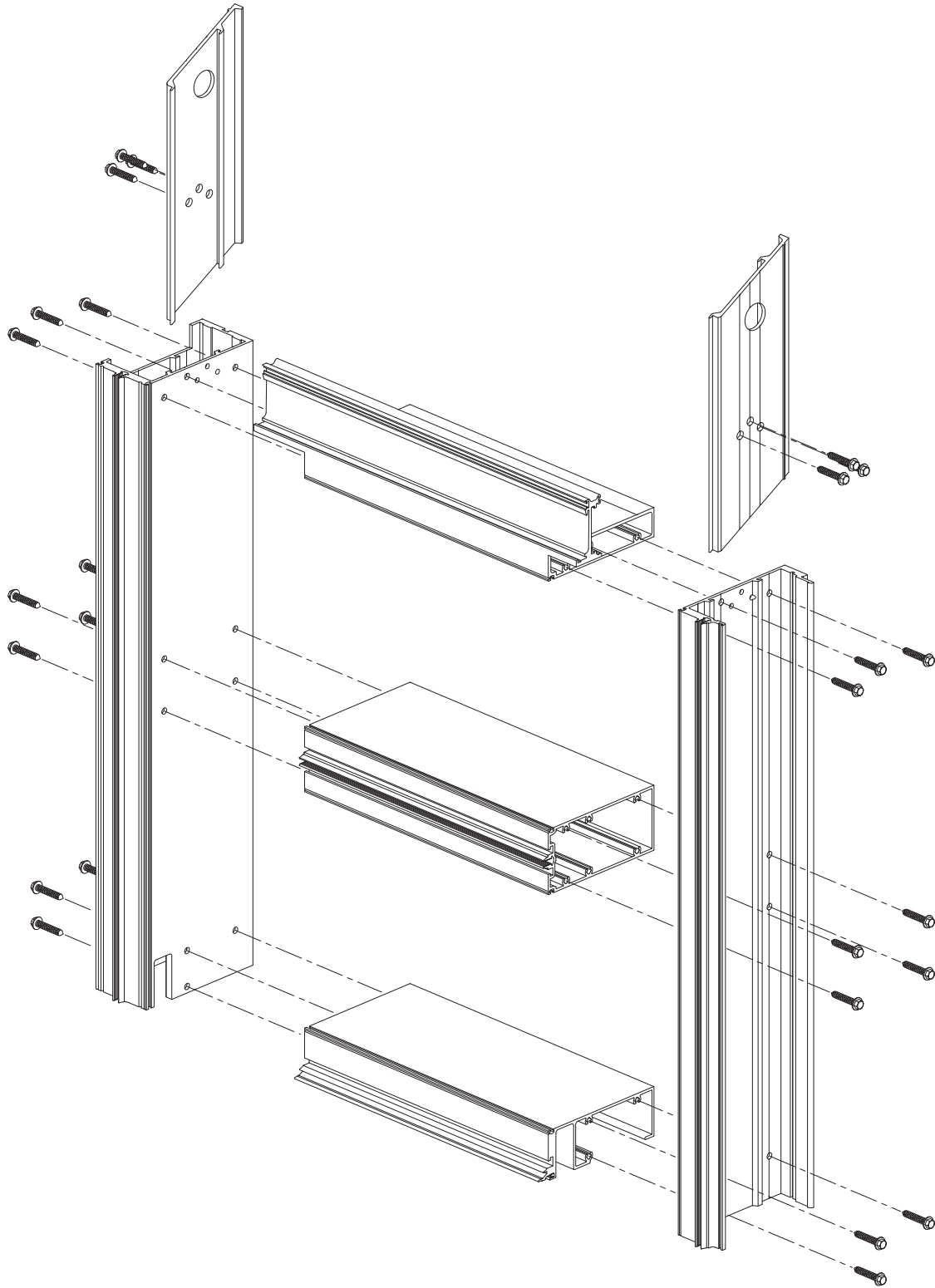

STEP 1: CS1 UNIT ASSEMBLY

STEP 1a

APPLY SEALANT TO FRAMING MEMBERS

-Clean, prime and apply sealant to both ends of horizontals and tops of verticals per typical unit detail and approved shop drawings.

See **Detail 1-1**.

Stacking Tray: seal at the front wall and bottom wall back to 1st screw spline.

Intermediate Horizontals: seal at the front of tube back to 1st screw spline.

Stacking Sill: seal at the front leg, 1" back along top of sill.

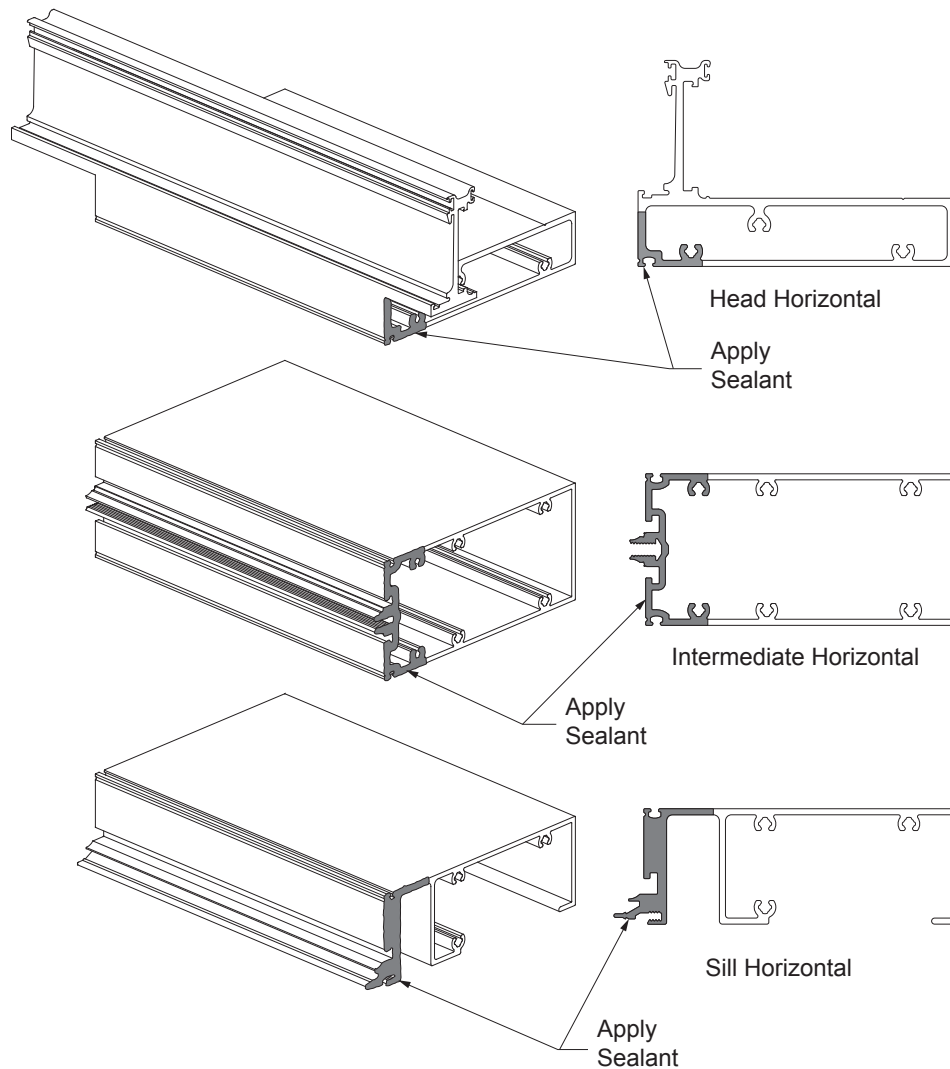

Detail 1-1

STEP 1: CS1 UNIT ASSEMBLY

STEP 1a (Continued)

APPLY SEALANT TO FRAMING MEMBERS

Vertical Mullions: Fill the reglets with sealant where the head, horizontals, and sills meet the verticals as shown in **Detail 1-2**. Also seal top of jamb mullion and male mullion.

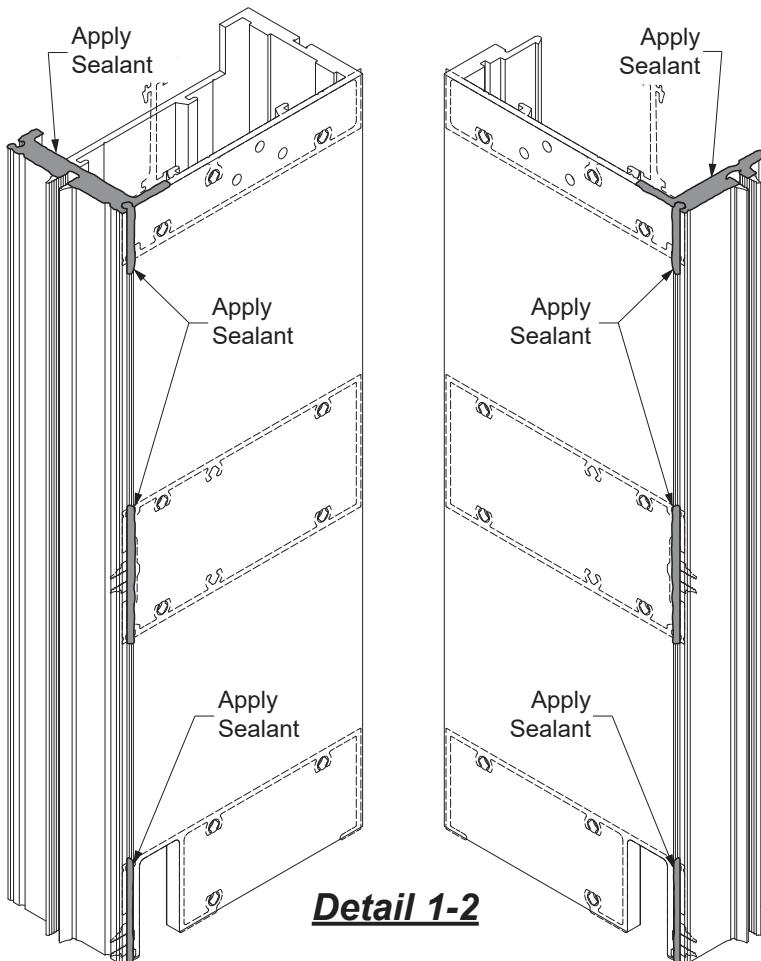
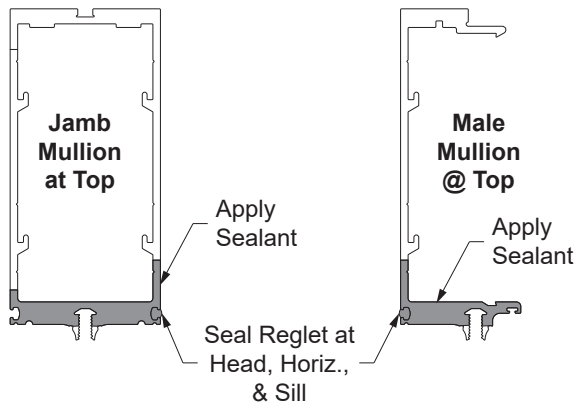

Detail 1-2

Note: Apply sealant in groove from the bottom of the male mullion up 4" minimum as shown on **Detail 1-3** and tool flush.

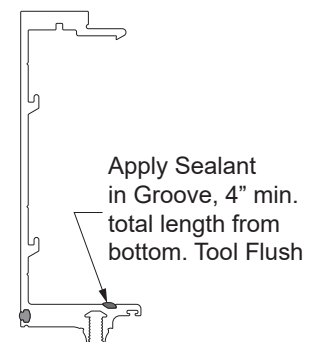

Male Mullion @ Bottom

Detail 1-3

STEP 1: CS1 UNIT ASSEMBLY

STEP 1b

ATTACH VERTICAL MULLIONS TO HORIZONTALS

-Position horizontal members aligning splines with screw holes in the jamb mullion and assemble with HC-1220-SS fasteners as shown in **Detail 1-4**. Wipe off excess sealant.

Note: Take care to keep sealant from getting into gasket raceways, setting block chair pockets and around stems.

-Tool all excess sealant flush.

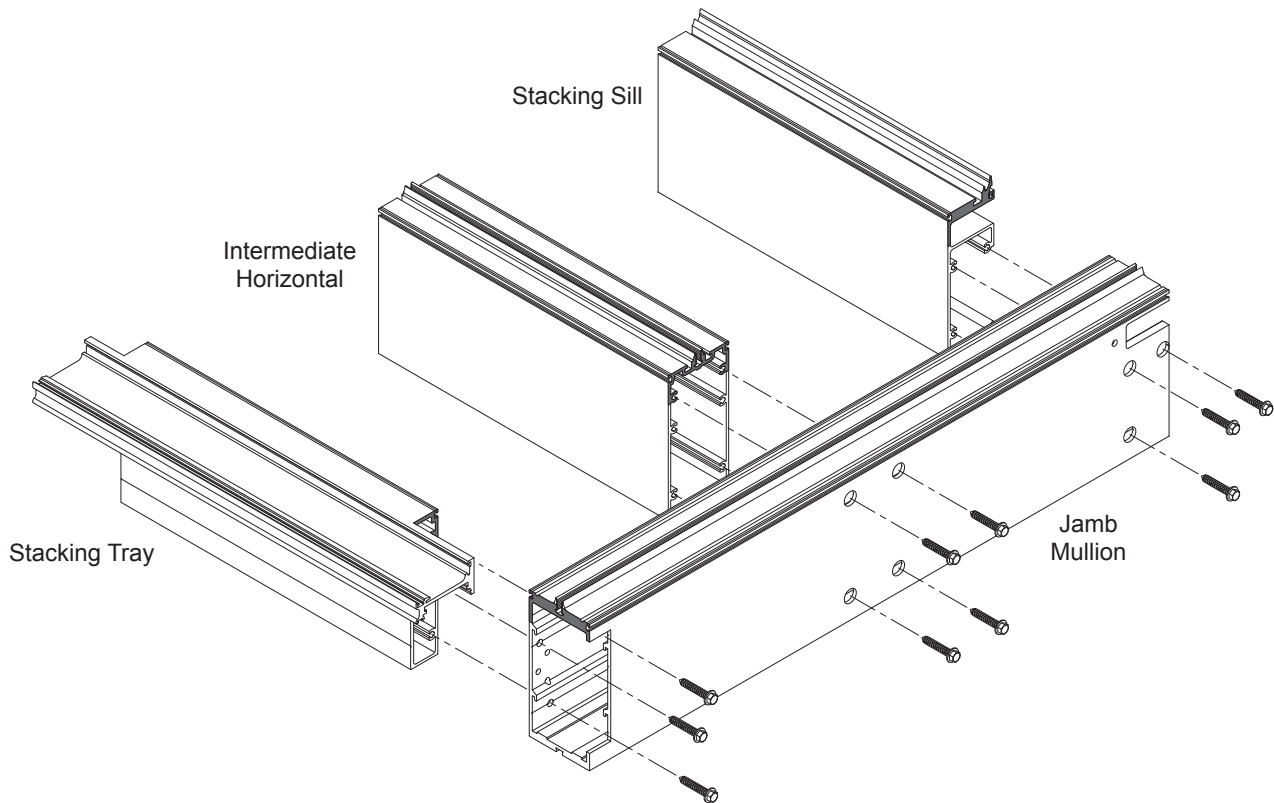

Detail 1-4

STEP 1: CS1 UNIT ASSEMBLY**STEP 1b (Continued)****ATTACH VERTICAL MULLIONS TO HORIZONTALS**

-Position horizontal members aligning splines with screw holes in the male mullion and assemble with HC-1220-SS fasteners as shown in **Detail 1-5**. Wipe off excess sealant.

Note: Take care to keep sealant from getting into gasket raceways, setting block chair pockets and around stems.

-Tool all excess sealant flush.

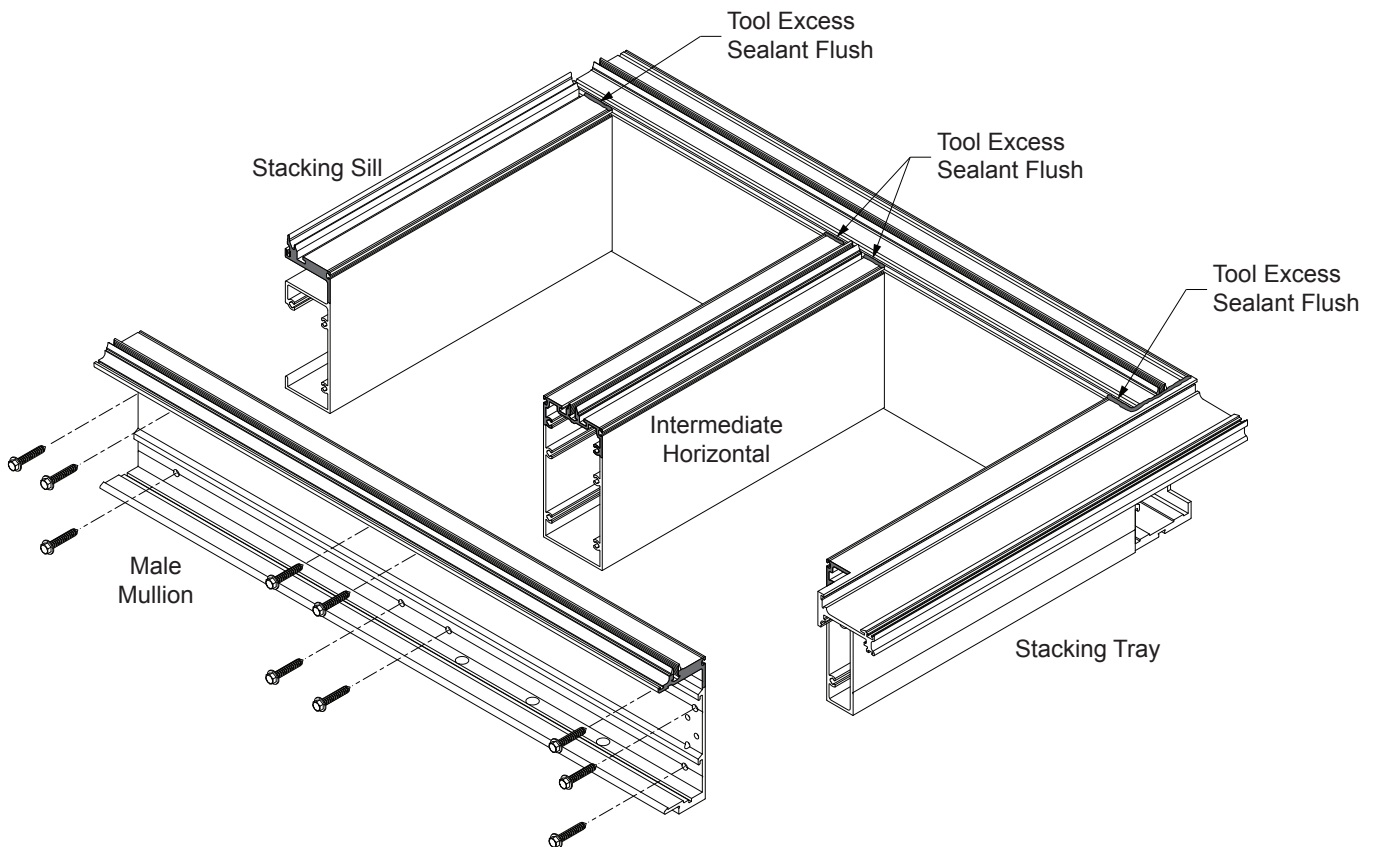
**Detail 1-5**

Unit CS1 shown,
Unit CS2 similar

STEP 2: CS1 PARTS INSTALLATION

**STEP 2a
JAMB PREPARATION**

-Using a PC-1008-SS fastener, install a jamb stack block (E1-7081) at bottom of jamb mullion just above expansion head. Fill void with sealant as shown in **Detail 1-6**.

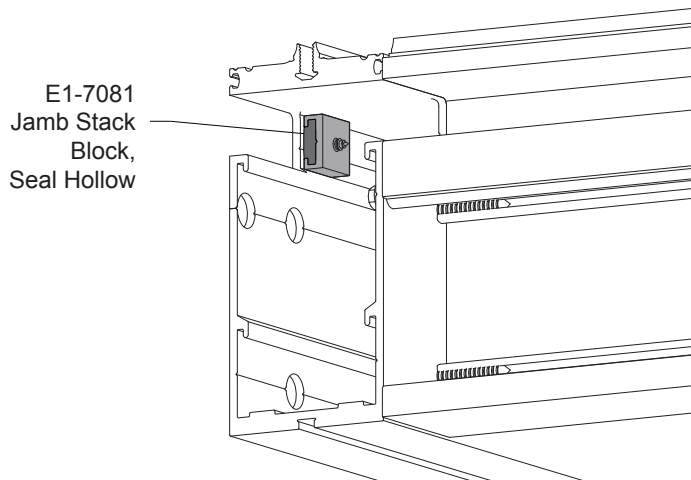
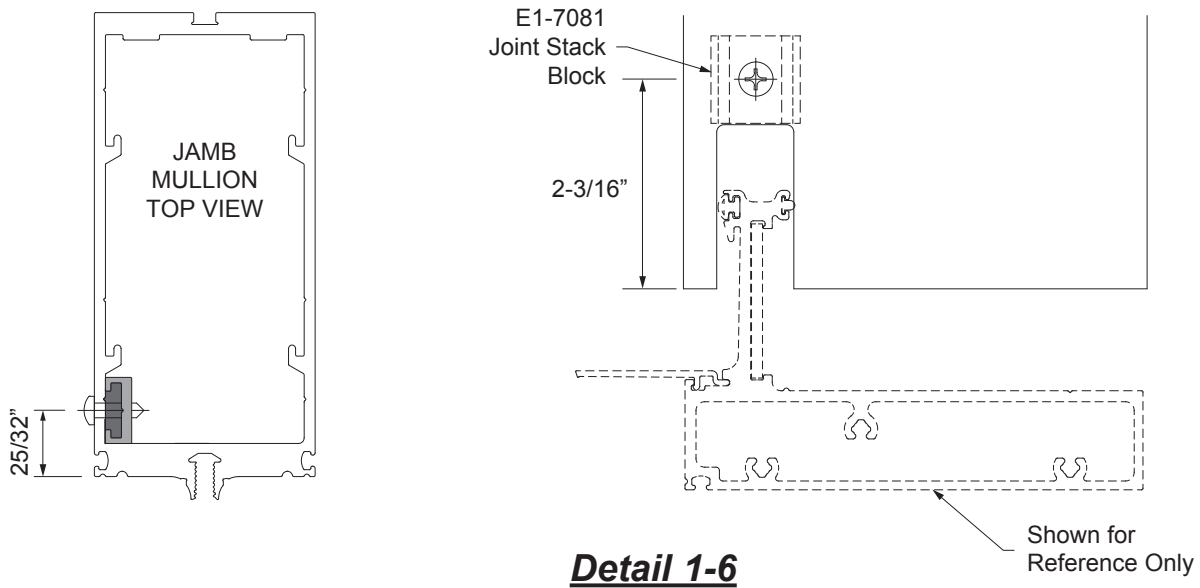

STEP 2: CS1 PARTS INSTALLATION

STEP 2b

INSTALL MULLION SLEEVES AND LEVELING ANCHORS

-Using HD-2520-W3 fasteners, install the mullion sleeves as shown in **Detail 1-7**, unless noted otherwise on the approved shop drawings.

Note: HD-2520-W3 fasteners (3 shown per sleeve) are sufficient for units weighing up to 2,350 lbs. Units weighing beyond that will require modifications to the anchor and/or fasteners.

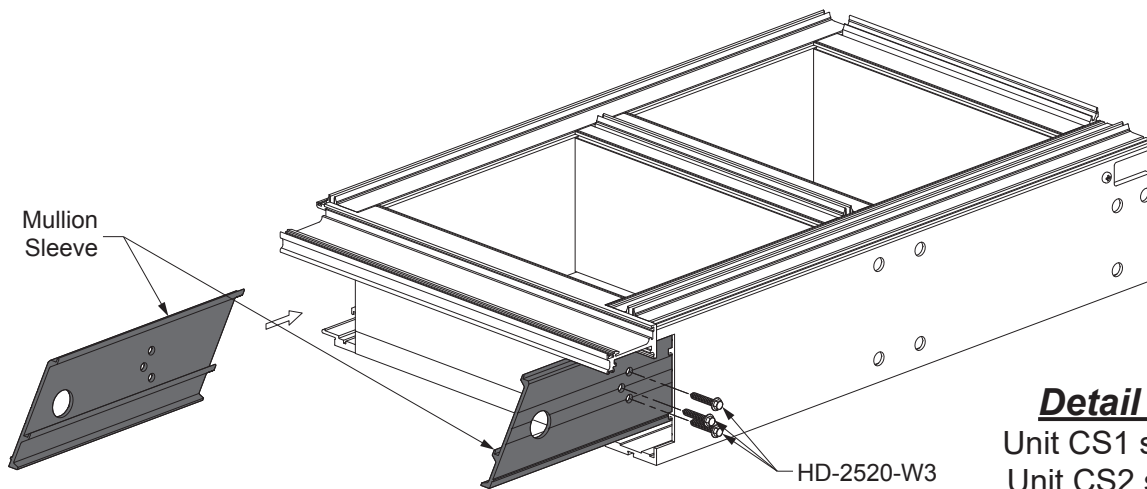

Detail 1-7
Unit CS1 shown,
Unit CS2 similar

-Place blocks at all four corners of the unit to keep the leveling anchors from coming into contact with the work table and also to maintain a level working surface. Install leveling anchors using fasteners as shown in **Detail 1-8**. Refer to shop drawings for leveling bracket locations.

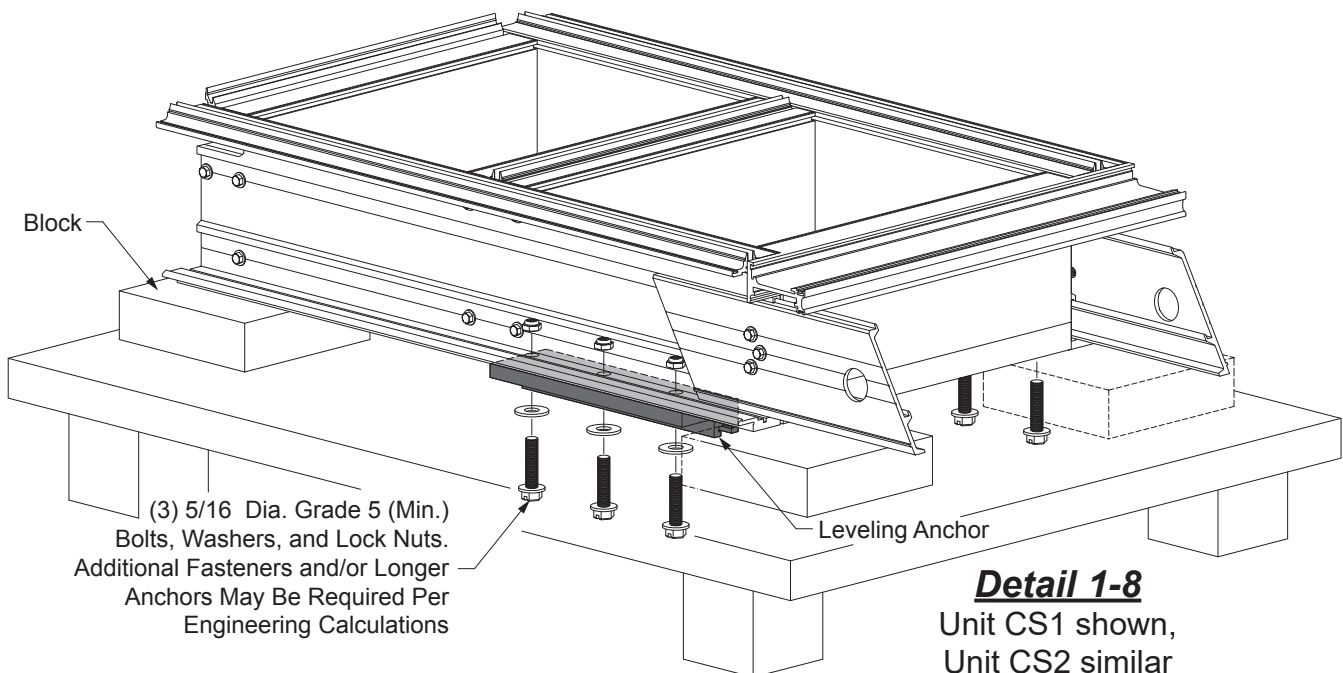

Detail 1-8
Unit CS1 shown,
Unit CS2 similar

STEP 2: CS1 PARTS INSTALLATION

STEP 2c

INSTALL STEEL REINFORCING (If Required)

-Install steel or aluminum reinforcing as required to the mullions per approved shop drawings. Shim and fasten as required. Coordinate installation of steel with anchor lug backup.

See **Detail 1-9**.

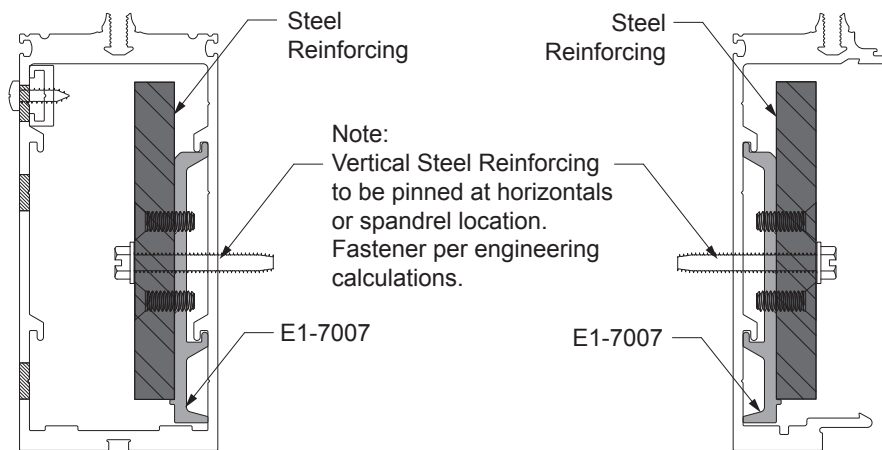

Detail 1-9

STEP 3: CS1 GASKET INSTALLATION**STEP 3a
INSTALL WEATHER SEAL GASKETS**

- Slide in weather seal gasket at the outer leg gasket raceway of the male mullion half as shown in **Detail 1-10**.
- Crimp raceway at both ends of mullion by deforming the retaining leg of the gasket raceway in order to keep the gasket from sliding out during unit installation. Gaskets to run full length of mullion.

Note: Weather seal gasket is handed. Install gasket in the orientation as shown below.

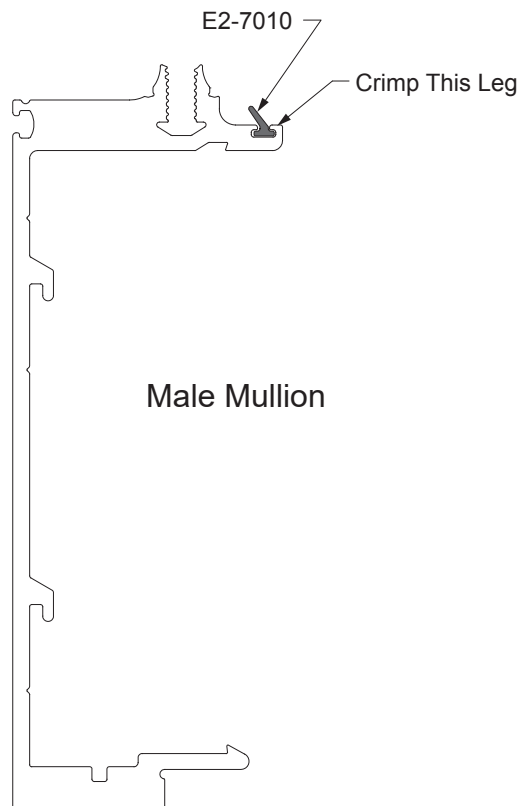

Detail 1-10

STEP 3: CS1 GASKET INSTALLATION

STEP 3b SEAL HORIZONTAL INTERSECTIONS

-Just prior to installing the E2-7001 interior gaskets, shoot silicone into the vertical glazing reglets at the corners where the horizontals meet the vertical mullion (including at the head and sill). Completely fill the reglet cavities 1/4" to 1/2" in both directions. Immediately install gaskets before sealant begins to cure.

See Detail 1-11.

Note: Inside and outside corner mullions will not require this.

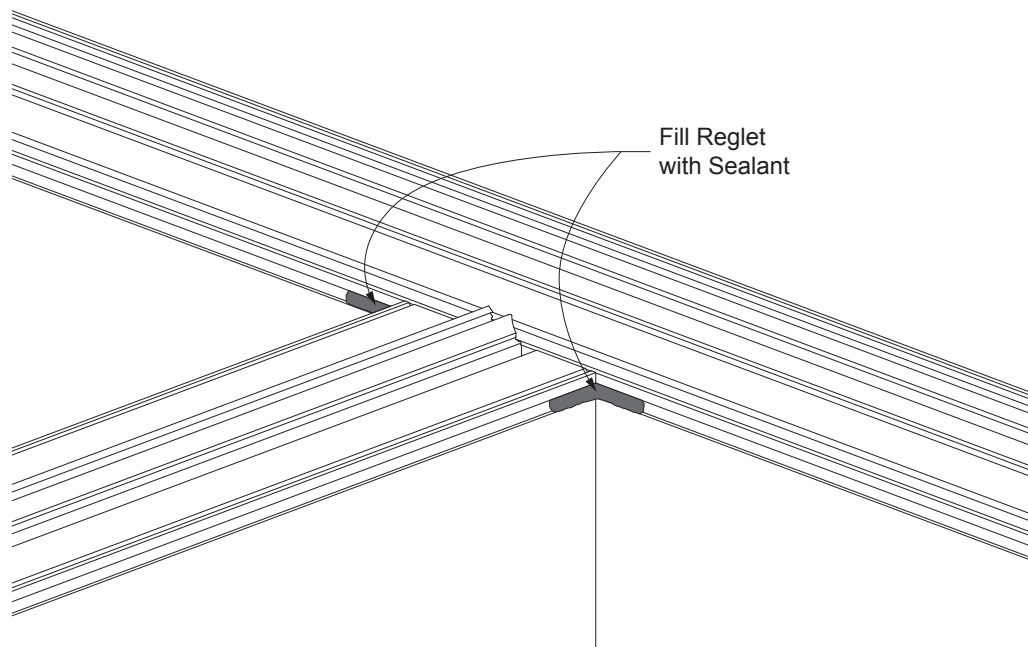

Detail 1-11
Unit CS1 shown,
Unit CS2, CS3,
& CS5 similar

STEP 3: CS1 GASKET INSTALLATION

**STEP 3b
INSTALL INTERIOR GLAZING GASKETS**

-Secure the assembled unit to a flat surface with the exterior facing up. Table must be flat and level, and must support frame at all locations. A unit glazed with any mullion deflection will cause installation problems. Additional bracing under the glass may be required with large glass lites to prevent glass deflection.

-Clean and prepare glass and aluminum surfaces in strict conformity with sealant manufacturer's specifications and requirements.

-Install E2-7001 interior gasket. Both vertical and horizontal gaskets are to be cut to D.L.O. Vertical gaskets are to be installed first, followed by the horizontal gaskets.

See **Detail 1-12**.

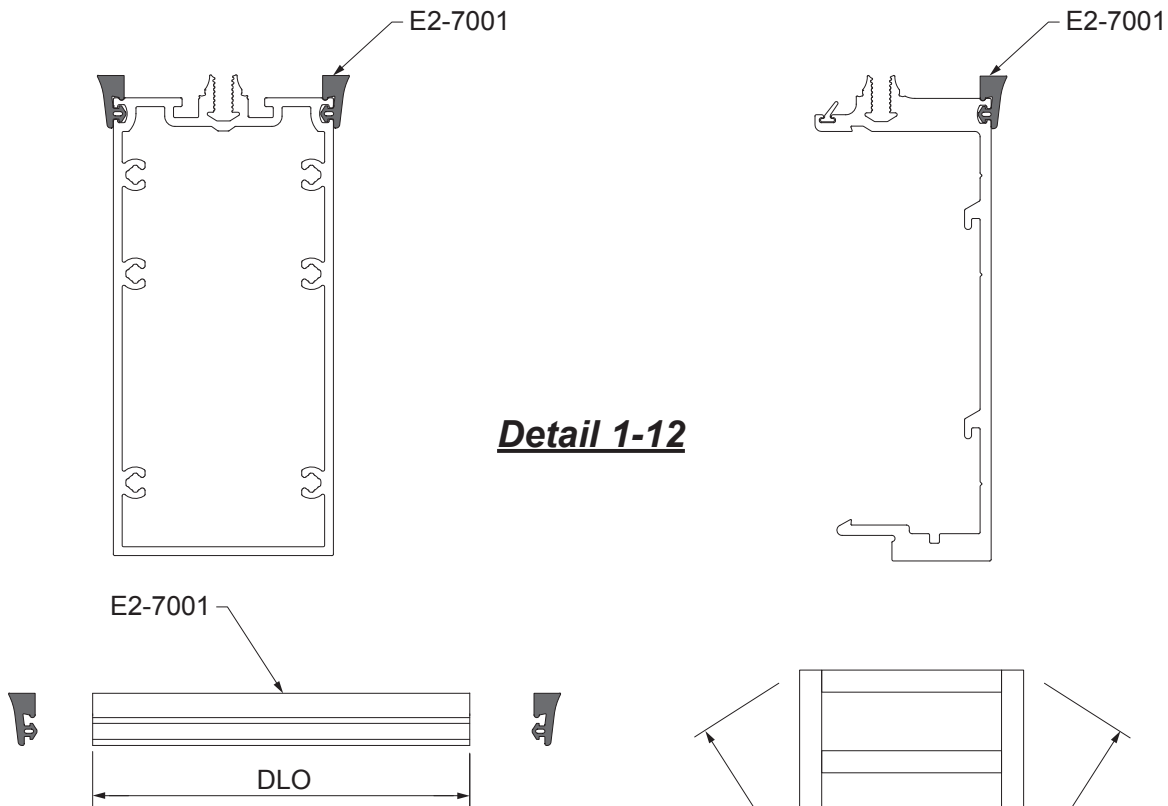

Note:
Before installing the glass, double-check squareness of frame by measuring diagonals. The maximum difference between diagonals is 1/16". Sight down mullions to make sure unit is not bowed. A unit glazed in a "out of square" or "bowed" position will cause installation problems.

STEP 4: CS1 GLASS INSTALLATION

STEP 4a

INSTALL SETTING BLOCK CHAIRS AND SETTING BLOCKS

-Apply setting block chairs and temporarily apply setting blocks oriented outward on setting block chairs placed at 1/4 points of horizontals as shown in **Detail 1-13**.

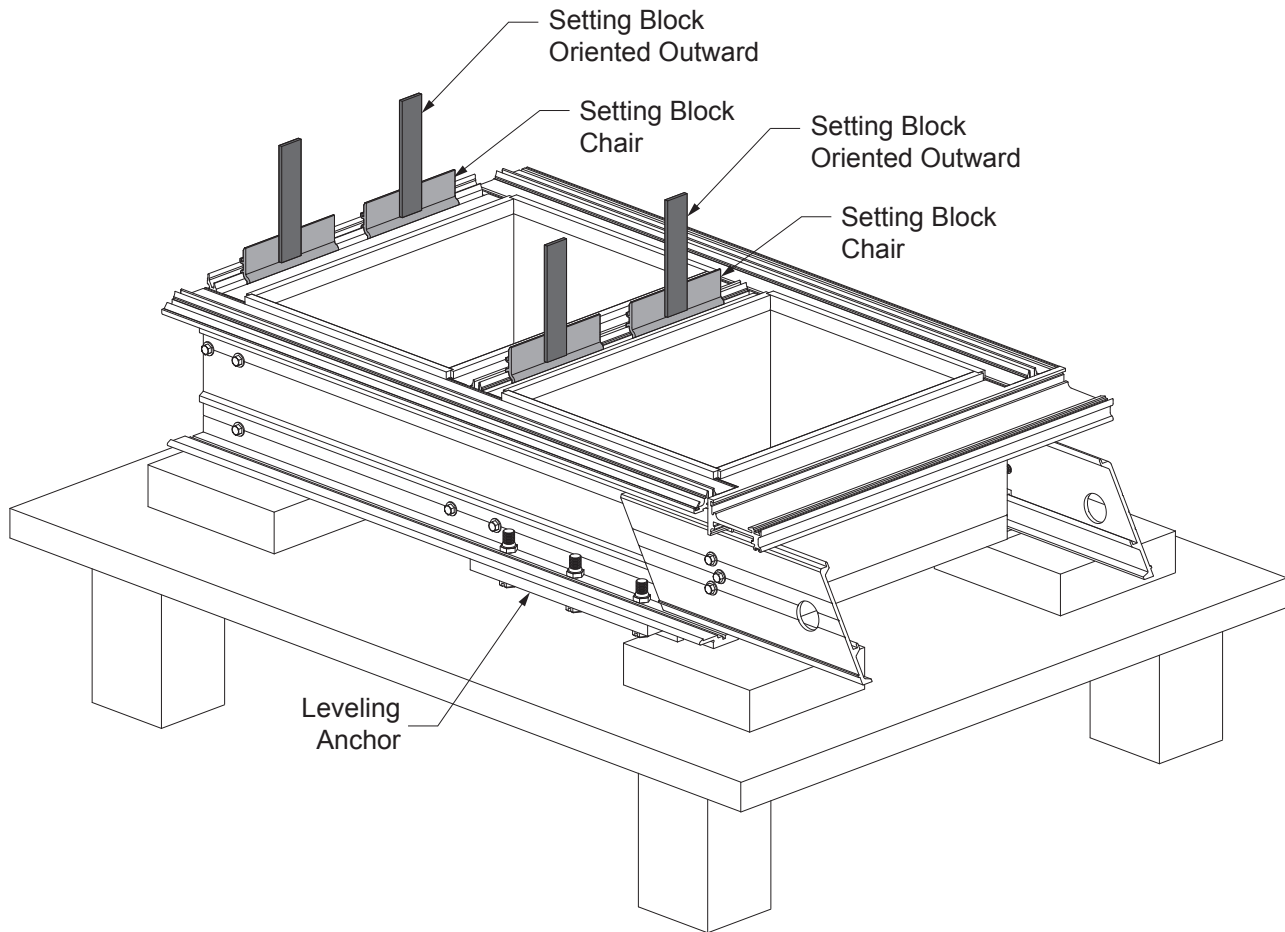

Detail 1-13
Unit CS1 shown,
Unit CS2 similar

STEP 4: CS1 GLASS INSTALLATION

**STEP 4b
INSTALL GLASS**

- Set the glass centered laterally in the D.L.O.
- Install glass by placing bottom edge against both setting blocks and lower into place.
- When glass is properly positioned, remove setting blocks. Take caution to not move glass during setting block removal.
- Reference shop details and glazing details for non typical conditions.

See **Detail 1-14**.

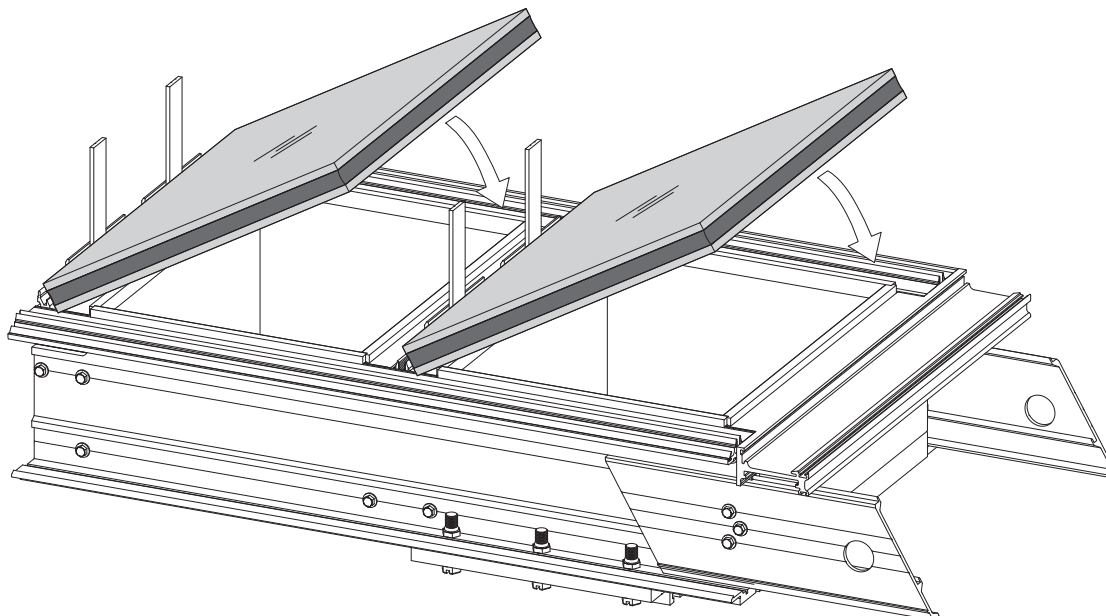
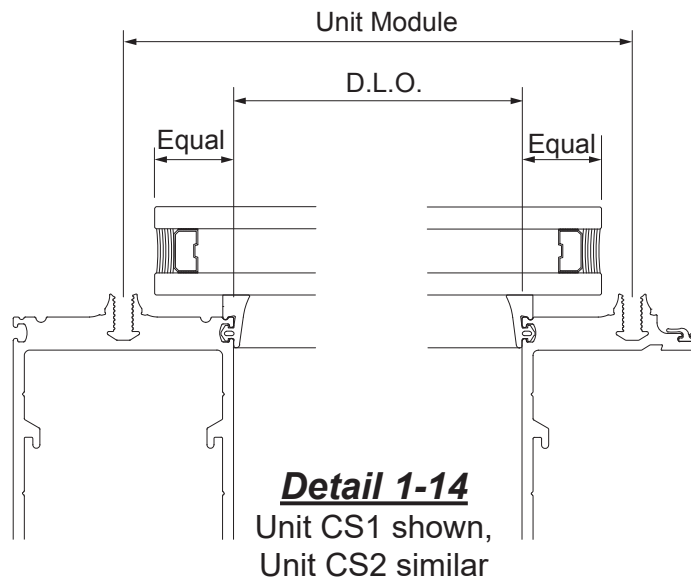

STEP 4: CS1 GLASS INSTALLATION

STEP 4b (Continued) INSTALL GLASS

- Ensure that the glass and metal surfaces are clean and prepared per sealant manufacturer's specifications and recommendations.
- Apply structural silicone sealant completely filling the space between the glass and the mullion. (Slide setting block chairs out of the way temporarily while sealing units.)
- Tool sealant. Clean out any excess sealant in horizontal groove and engagement areas.

See **Detail 1-15**.

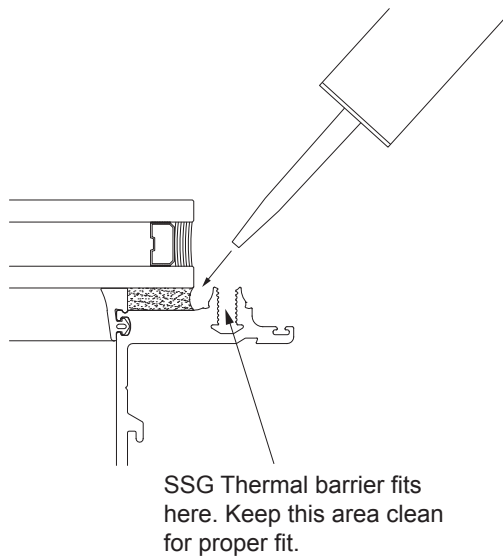

Detail 1-15

STEP 4: CS1 GLASS INSTALLATION**STEP 4b (Continued)
INSTALL GLASS**

-Apply silicone in I.G.U. cap trace. Rotate and hook in E3-7002 I.G.U. cap. Apply flush with the perimeter edge of the jamb. Tool sealant flush with top of I.G.U. cap.

See **Detail 1-16**.

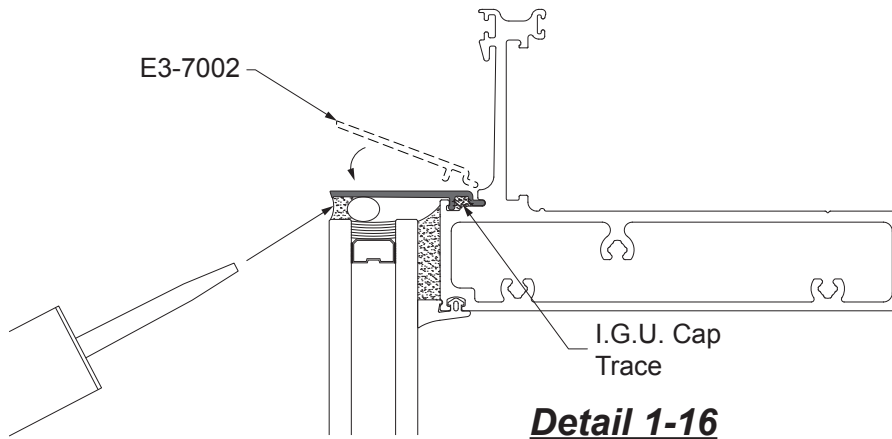

-Push in 3/8" backer rod and seal around the glass and under the I.G.U. cap as shown in **Detail 1-17**. Tool sealant.

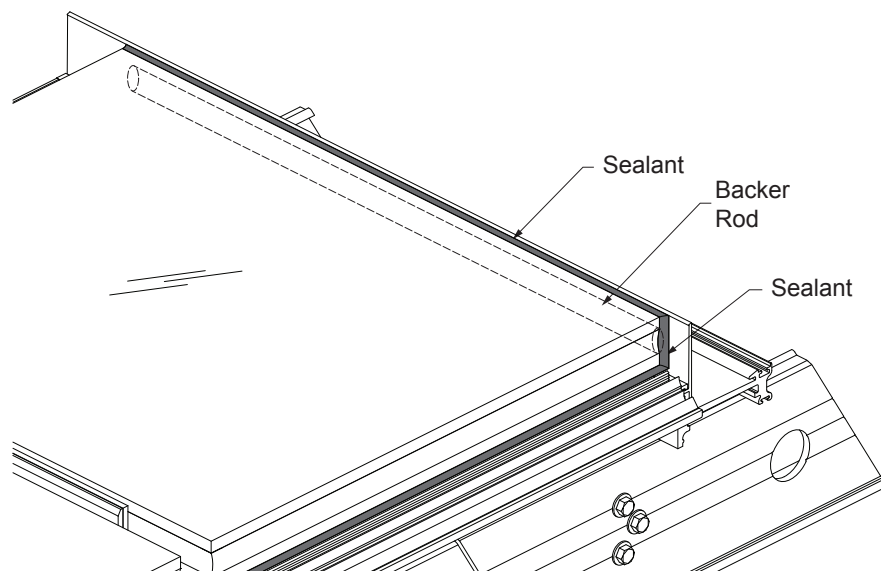
**Detail 1-17**

Unit CS1 shown,
Unit CS2 similar

STEP 4: CS1 GLASS INSTALLATION

STEP 4c

INSTALL THERMAL SHIELD

-Before installing the thermal shield (E3-7003 or E3-7016), apply a few dabs of sealant to keep it in place.

-Snap thermal shield into the front of the stacking sill, centered on the D.L.O. See **Detail 1-18**.

-Install backer rods to the joint and completely fill intermediate horizontal and stacking sill joints with sealant as shown on **Detail 1-19**.

Tool excess sealant to ensure a complete seal. Be sure to keep sealant out of horizontal groove and engagement areas.

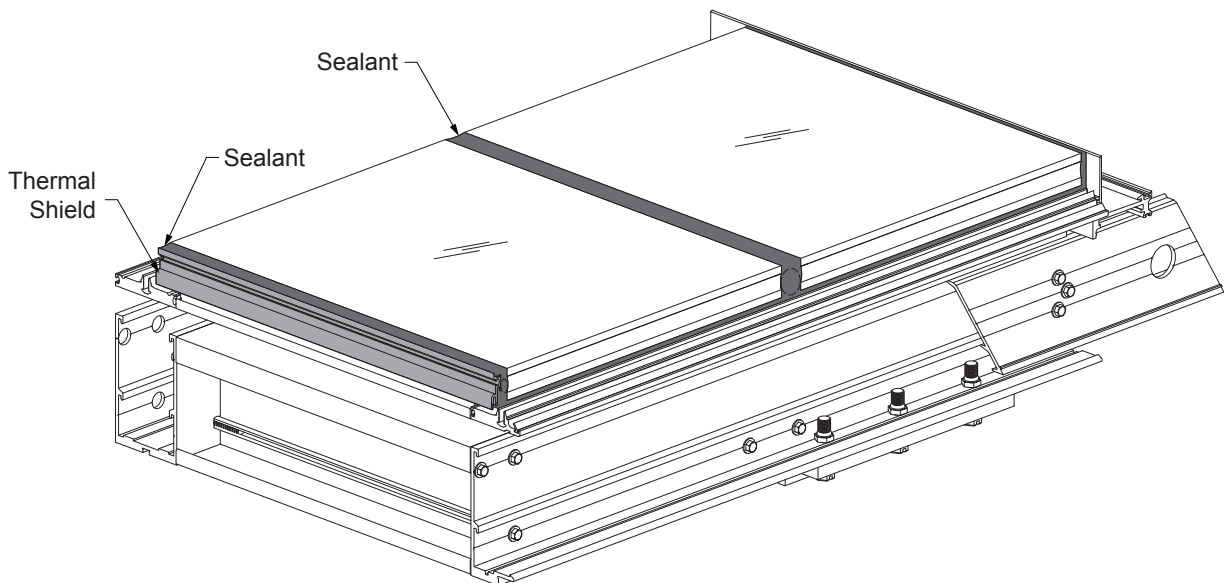
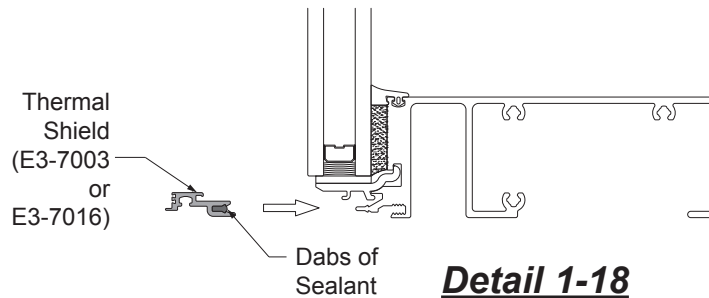

Detail 1-19
Unit CS1 shown,
Unit CS2 similar

STEP 5: CS1 THERMAL BARRIER & WEATHERSEAL INSTALLATION

**STEP 5a
INSTALL JAMB ADAPTOR**

- Install glazing spacer tape E2-0110 onto the jamb mullion, staggered as shown below in **Detail 1-20**.
- Insert a backer rod into the ends of the SSG jamb adaptor base E9-7052.
- Adhere the jamb adaptor base onto the glazing spacer tape.
- Snap the jamb adaptor E9-7053 onto the jamb adaptor base.

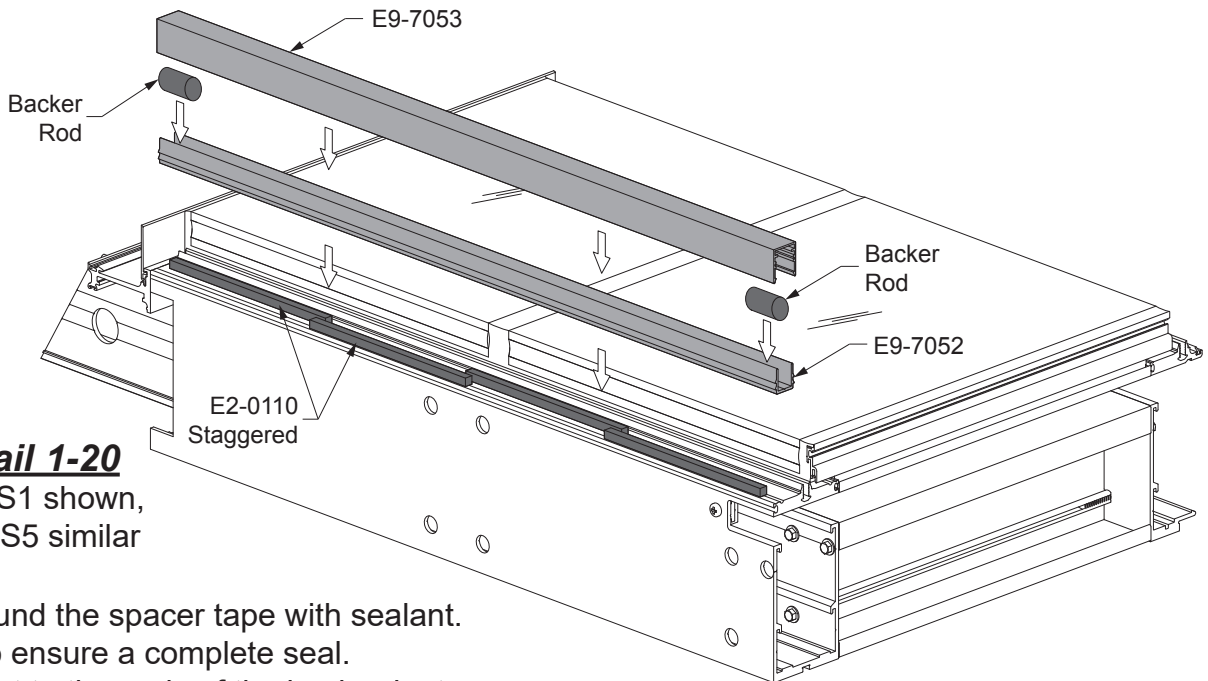

Detail 1-20

Unit CS1 shown,
Unit CS5 similar

- Fill void around the spacer tape with sealant.
Tool flush to ensure a complete seal.
- Apply sealant to the ends of the jamb adaptor.
Seal under I.G.U. Cap at the stacking tray.
Tool off any excess sealant.

See **Detail 1-21**.

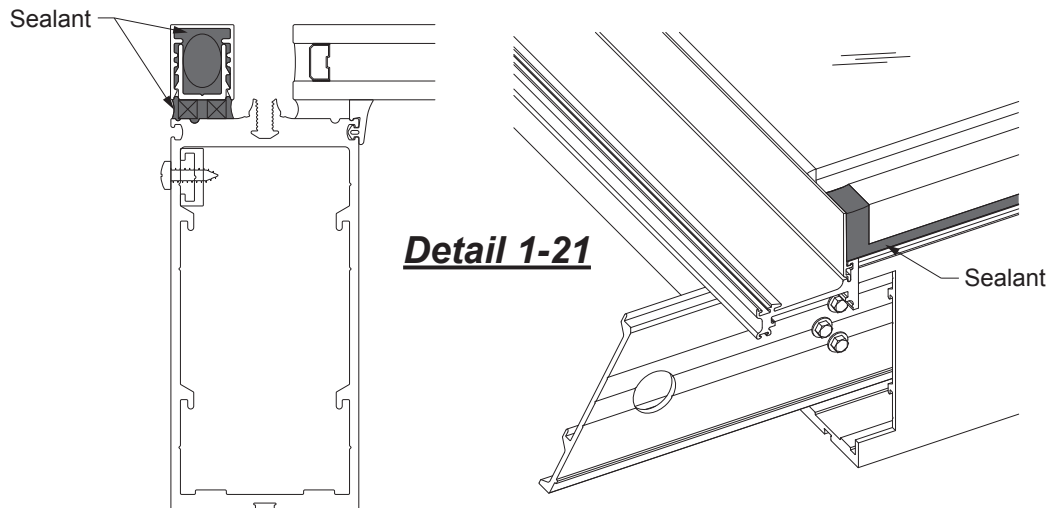

STEP 5: CS1 THERMAL BARRIER & WEATHERSEAL INSTALLATION

STEP 5b INSTALL SSG THERMAL BARRIER & GASKET

- Snap in SSG Thermal Barrier (E3-7013 or E3-7011) into the mullion raceways.
 - Push in the SSG Wiper Gasket E2-7009 into the SSG thermal barrier. Align according to unit module.
- See **Detail 1-22**.

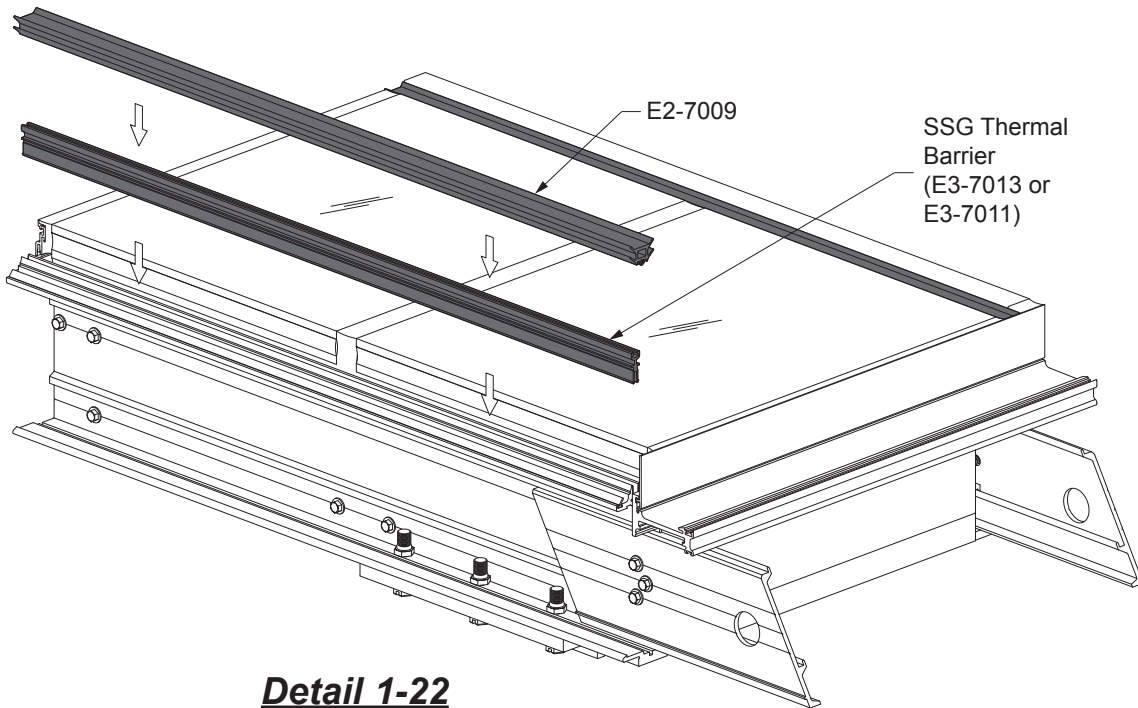

Detail 1-22
Unit CS1 shown,
Unit CS2 similar

- Apply a dab of sealant at both ends of the gasket and thermal barrier to hold them in place.

See **Detail 1-23**.

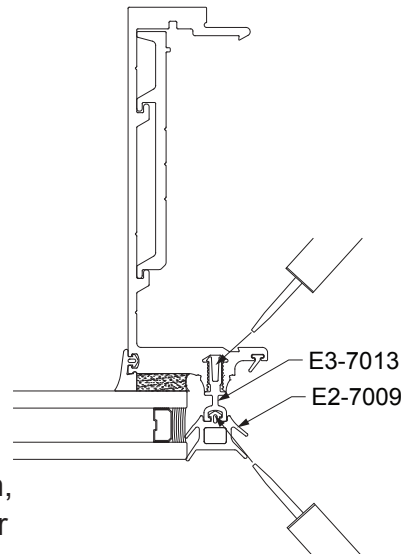

Detail 1-23
Unit CS1 shown,
Unit CS2 similar

STEP 5: CS1 THERMAL BARRIER & WEATHERSEAL INSTALLATION**STEP 5c****INSTALL STACKING SILL WEATHER SEAL**

-Locate center of E2-7016 gasket with center of unit. At jambs, locate end of gasket 2 1/2" beyond D.L.O. on jamb side.

-Crimp leg of stacking sill at 1/4 points to hold E2-7016 stacking sill weather seal in place.

See **Detail 1-24**.

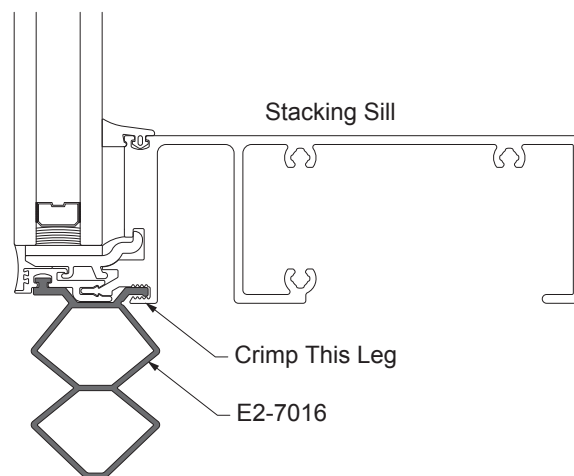

Detail 1-24

STEP 5: CS1 THERMAL BARRIER & WEATHERSEAL INSTALLATION

STEP 5d

INSTALL STACKING TRAY ACCESSORIES

- Slide in E2-3906 stack isolator into stacking tray as shown in **Detail 1-25**.
- Slide in E1-7001 stack joint plate at male mullion side. Secure stack joint plate with tape. Final stack joint plate adjustment will be made once the unit is installed on jobsite.
- Slide in E2-7004 air/water seal gasket positioned flush at the perimeter edge of jamb and extending 6" beyond the male mullion as shown in **Detail 1-26**. Affix the gasket with a small amount of silicone.

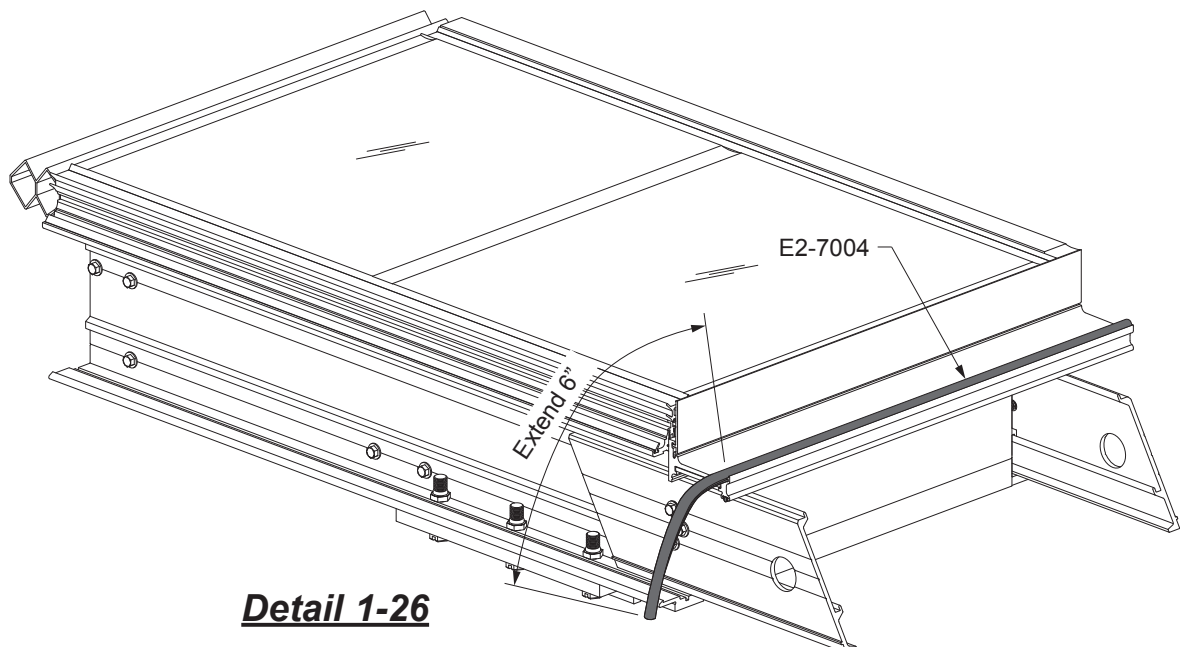
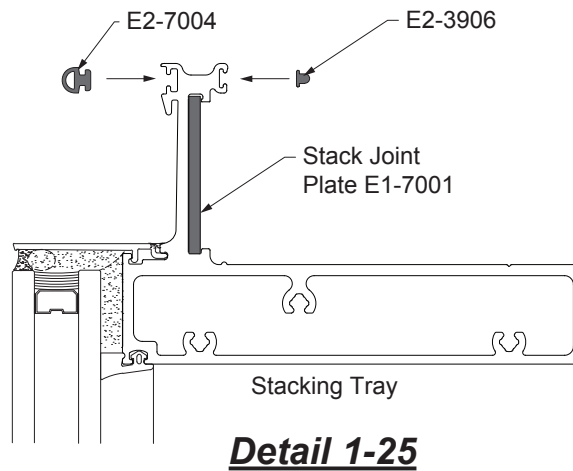

CS2 TABLE OF CONTENTS

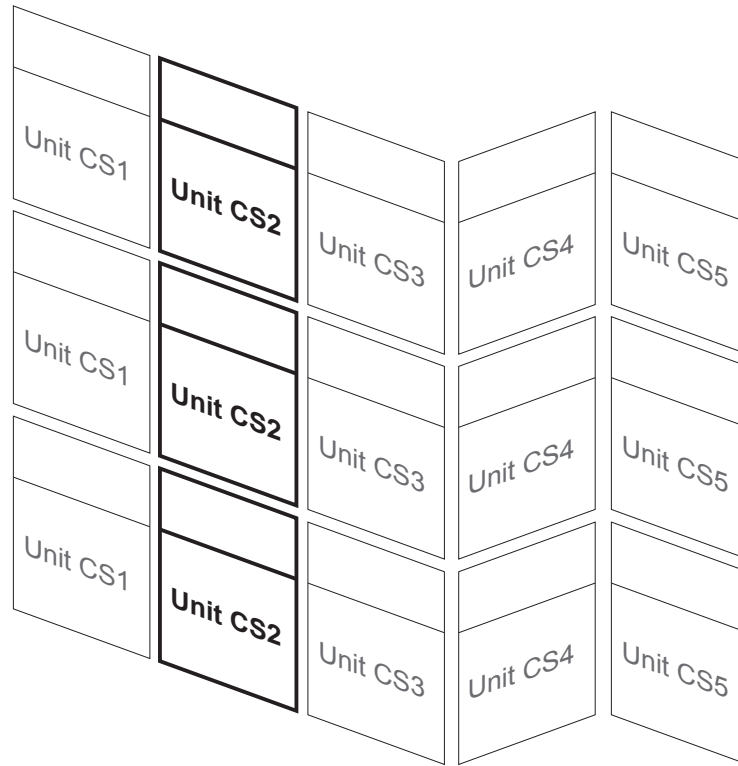

The following is intended for use as a guide for assembly of **Unit CS2** of the **YUW 750 XT 4-Sided SSG Curtain Wall System**. It is organized into five steps which will take you from assembly of parts to completed units.

Step 1: CS2 Unit Assembly	Pages 23 to 27
Step 2: CS2 Parts Installation	Pages 28 & 29
Step 3: CS2 Gasket Installation	Page 30
Step 4: CS2 Glass Installation	Page 31
Step 5: CS2 Thermal Barrier & Weatherseal Installation.....	Pages 31 & 32

Care should be taken to ensure you have inventory of all items required to complete this assembly. We recommend you refer to the parts list (pages iv - viii) as a reference and compare it to your specific project to ensure you have all the correct parts and tools required to complete the assembly.

STEP 1: CS2 UNIT ASSEMBLY

MAJOR COMPONENTS

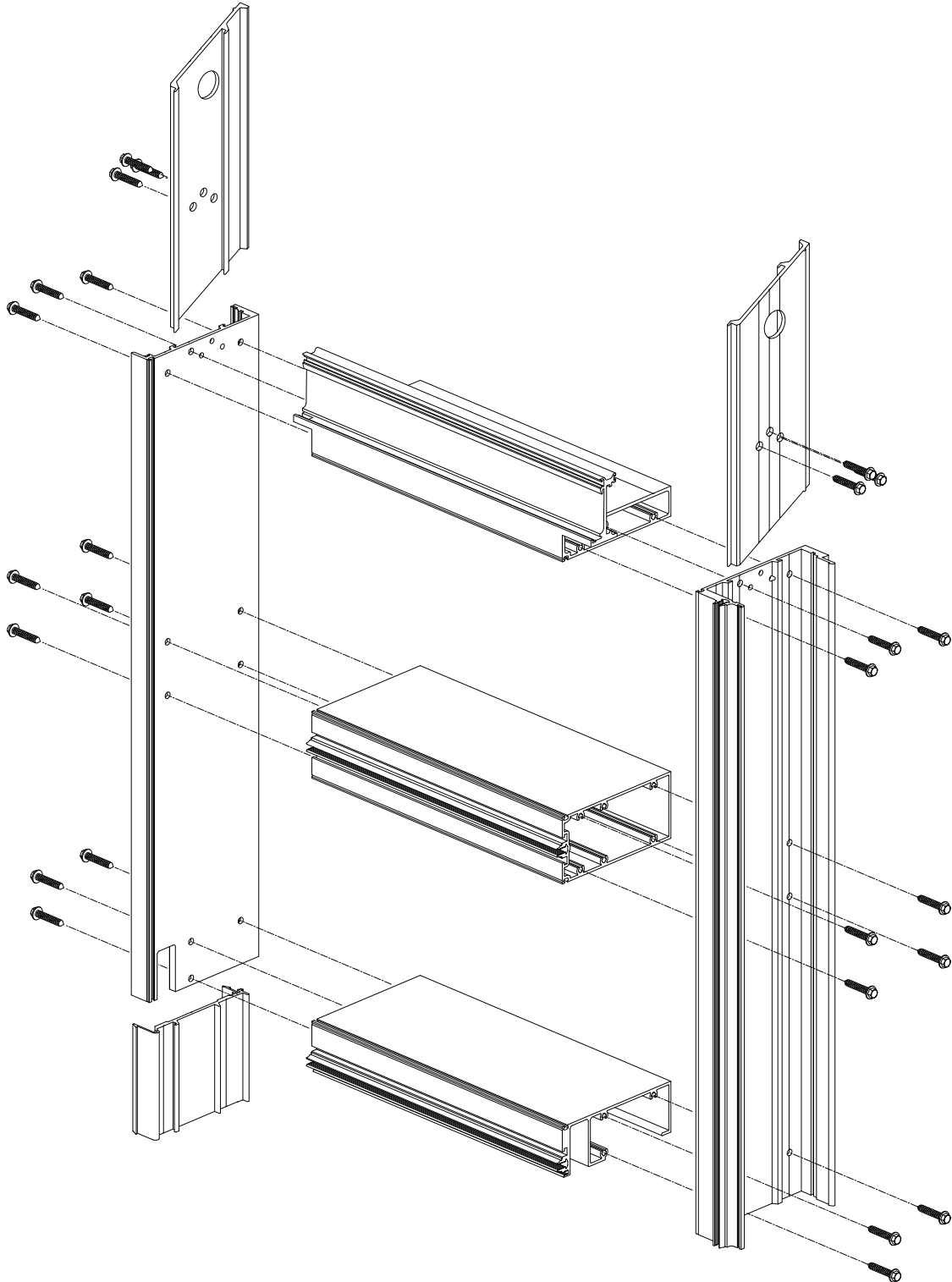

STEP 1: CS2 UNIT ASSEMBLY

**STEP 1a
APPLY SEALANT TO FRAMING MEMBERS**

-Clean, prime and apply sealant to both ends of horizontals and tops of verticals per typical unit detail and approved shop drawings.

See **Detail 2-1**.

Stacking Tray: seal at the front wall and bottom wall back to 1st screw spline.

Intermediate Horizontals: seal at the front of tube back to 1st screw spline.

Stacking Sill: seal at the front leg, 1" back along top of sill.

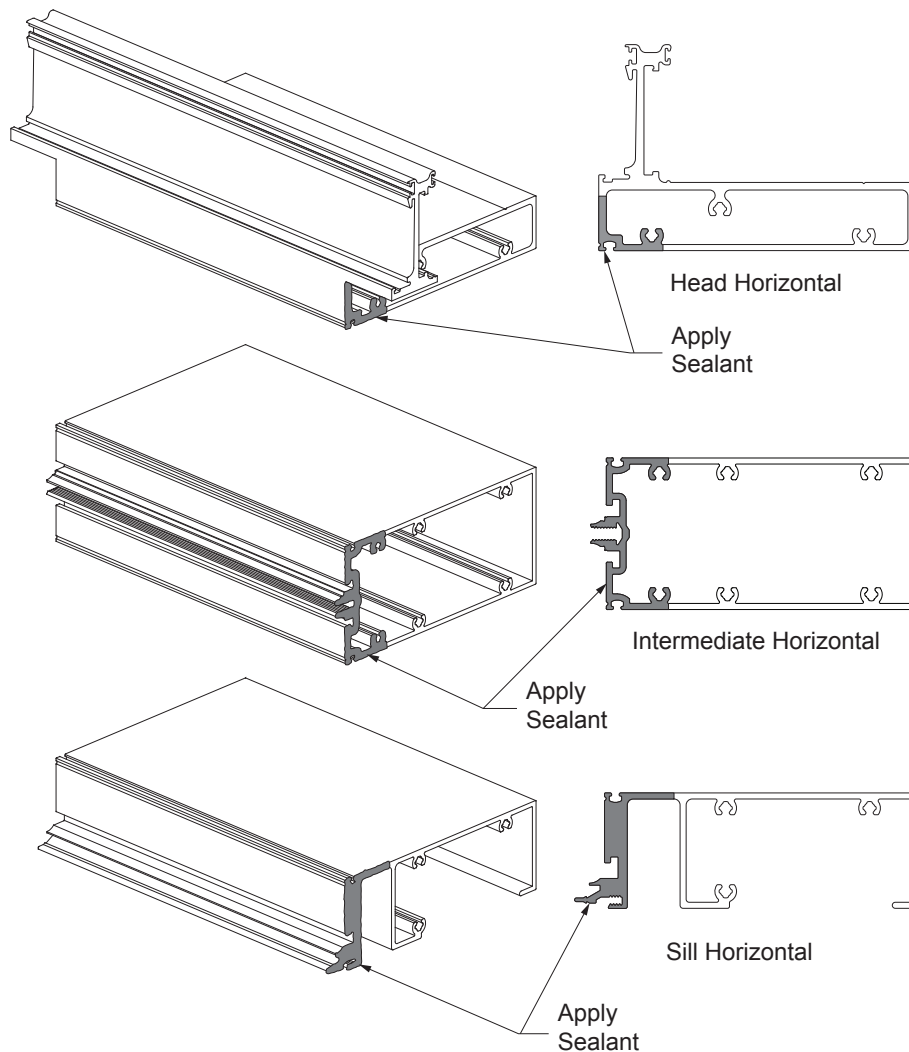

Detail 2-1

STEP 1: CS2 UNIT ASSEMBLY

STEP 1a

APPLY SEALANT TO FRAMING MEMBERS

Vertical Mullions: seal top of female mullion and male mullion as shown in **Detail 2-2**.

Note: Apply sealant in groove from the bottom of the male mullion up 4" minimum as shown on **Detail 2-3** and tool flush. Also apply sealant in the gasket reglets on both mullions at each horizontal location and tool flush.

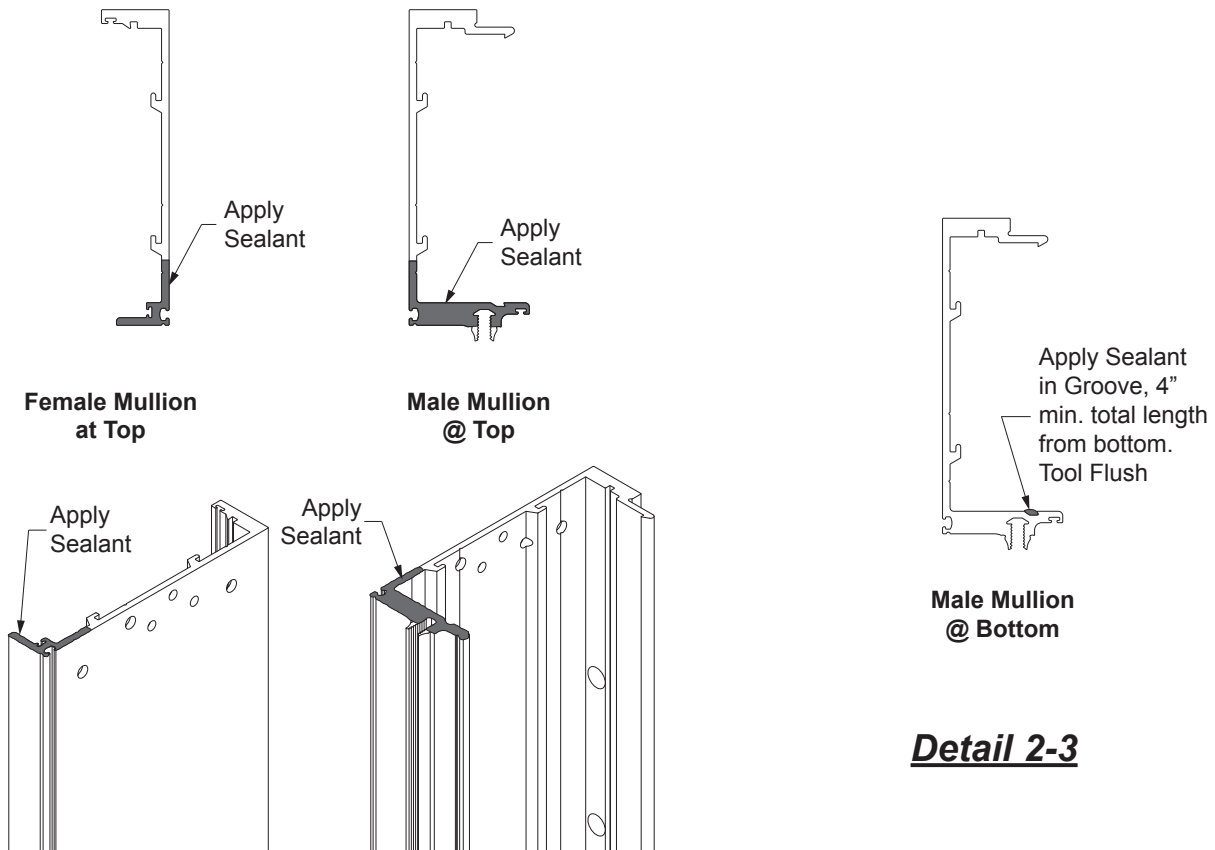

Detail 2-2

Detail 2-3

STEP 1: CS2 UNIT ASSEMBLY**STEP 1b****ATTACH VERTICAL MULLIONS TO HORIZONTALS**

-Position horizontal members aligning splines with screw holes in the female mullion and assemble with HC-1220-SS fasteners as shown in **Detail 2-4**. Wipe off excess sealant.

Note: Take care to keep sealant from getting into gasket raceways, setting block chair pockets and around stems.

-Tool all excess sealant flush.

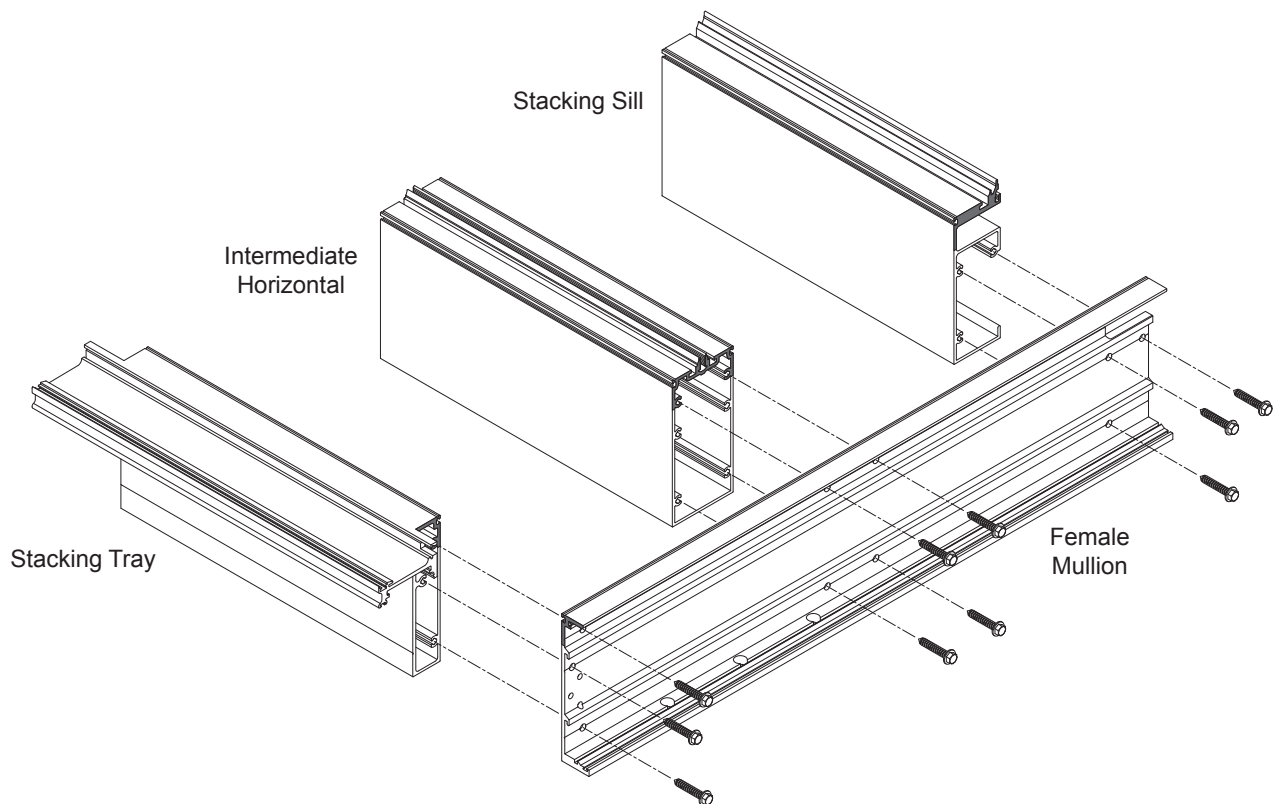
**Detail 2-4**

STEP 1: CS2 UNIT ASSEMBLY

STEP 1b

ATTACH VERTICAL MULLIONS TO HORIZONTALS

-Position horizontal members aligning splines with screw holes in the male mullion and assemble with HC-1220-SS fasteners as shown in **Detail 2-5**. Wipe off excess sealant.

Note: Take care to keep sealant from getting into gasket raceways, setting block chair pockets and around stems.

-Tool all excess sealant flush.

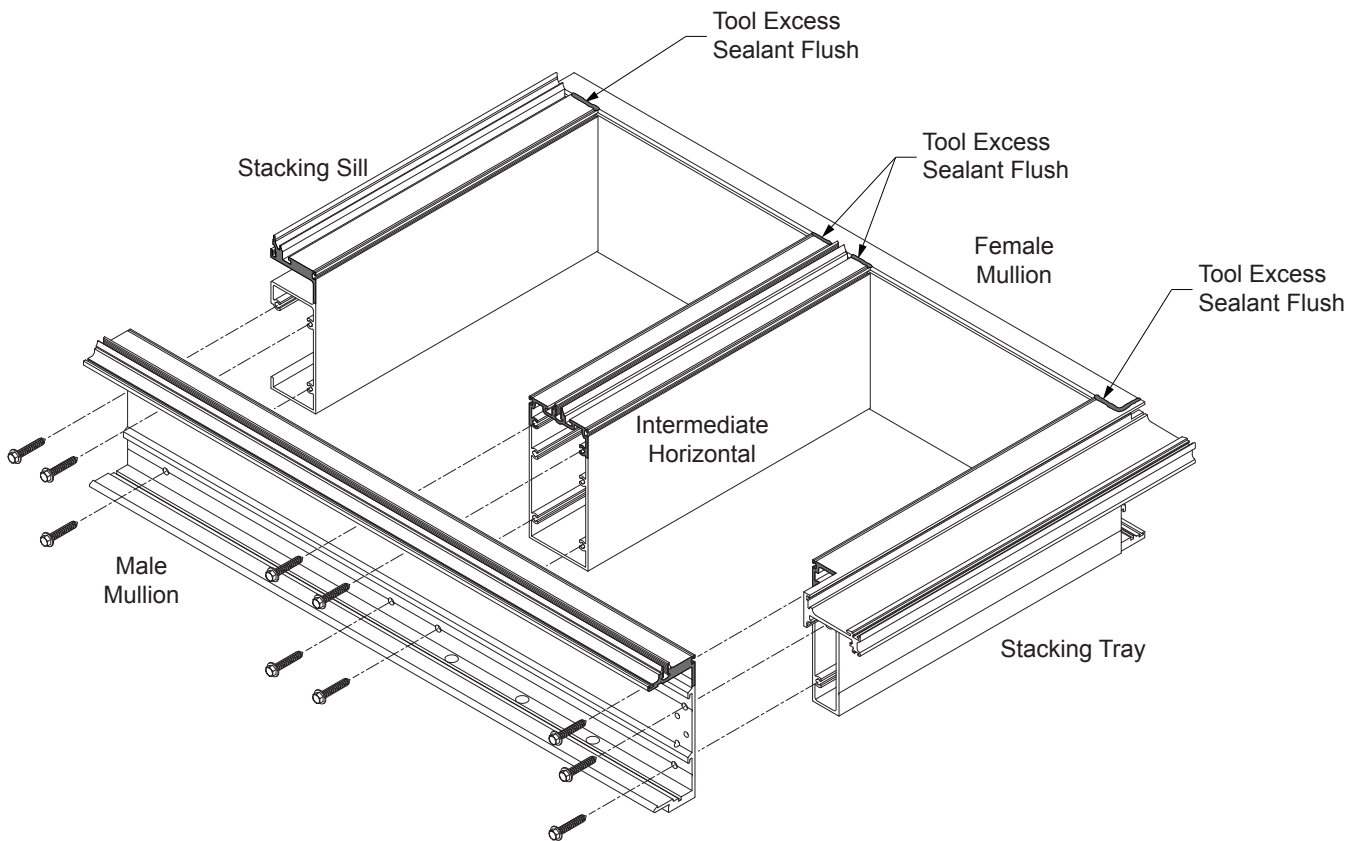

Detail 2-5

STEP 2: CS2 PARTS INSTALLATION**STEP 2a****INSTALL MULLION SLEEVES AND LEVELING ANCHORS**

-Refer to **CS1 Parts Installation, Step 2b** on **Page 8**.

STEP 2b**INSTALL MULLION INTERLOCKING CLIPS**

Mullion interlock clips are required. Refer to approved shop drawings / engineering calculations for location and quantity.

-Install mullion interlock clips into the female mullion half and crimp in place.
See **Detail 2-6** and **Detail 2-7**.

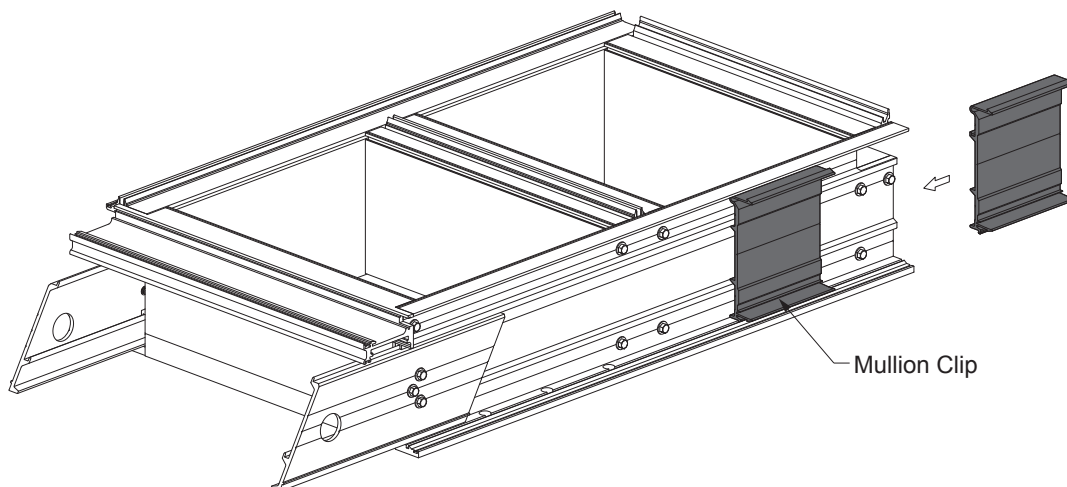

Detail 2-6

STEP 2: CS2 PARTS INSTALLATION

STEP 2b (Continued)

INSTALL MULLION INTERLOCKING CLIPS

NOTE: If clip location coincides with an anchor lug or horizontal location, crimp clips in place just above or below to allow for tapping bar or screw installation.

****REVIEW WITH PROJECT ENGINEER TO MAKE SURE IF ADDITIONAL INTERLOCKING CLIPS ARE REQUIRED.

If steel is being installed in mullion, mullion interlock clips will have to be installed with steel after bay assembly to allow access to fasten horizontal mullions.

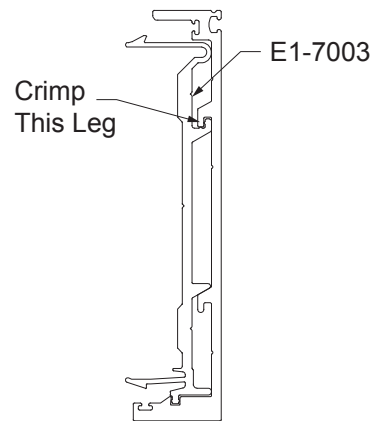

Detail 2-7

STEP 2c

INSTALL STEEL REINFORCING (If Required)

-Install steel or aluminum reinforcing as required to the mullions per approved shop drawings. Shim and fasten as required. Coordinate installation of steel with anchor lug backup.

See **Detail 2-8**.

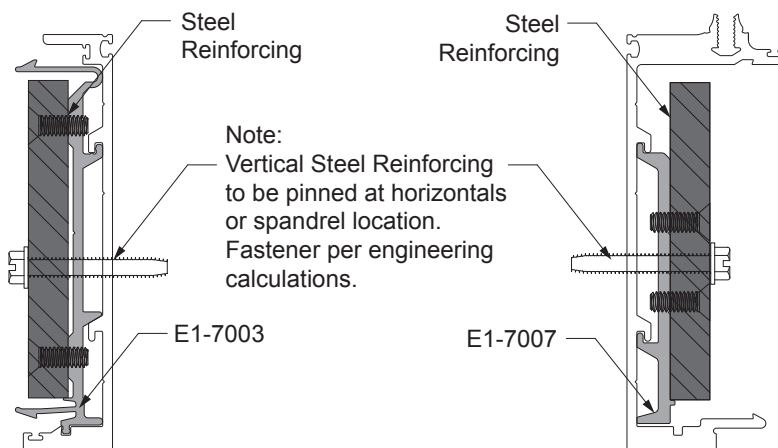

Detail 2-8

STEP 3: CS2 GASKET INSTALLATION

**STEP 3a
INSTALL WEATHER SEAL GASKETS**

- Slide in weather seal gasket at the outer leg gasket raceway of the male mullion and into the inner leg gasket raceway of the female mullion as shown in **Detail 2-9**.
- Slide in the air water seal gasket at the outer leg gasket raceway of the female mullion.
- Crimp raceway at both ends of mullion by deforming the retaining leg of the gasket raceway in order to keep the gasket from sliding out during unit installation. Gaskets to run full length of mullion.

Note: Weather seal gasket is handed. Install gasket in the orientation as shown below.

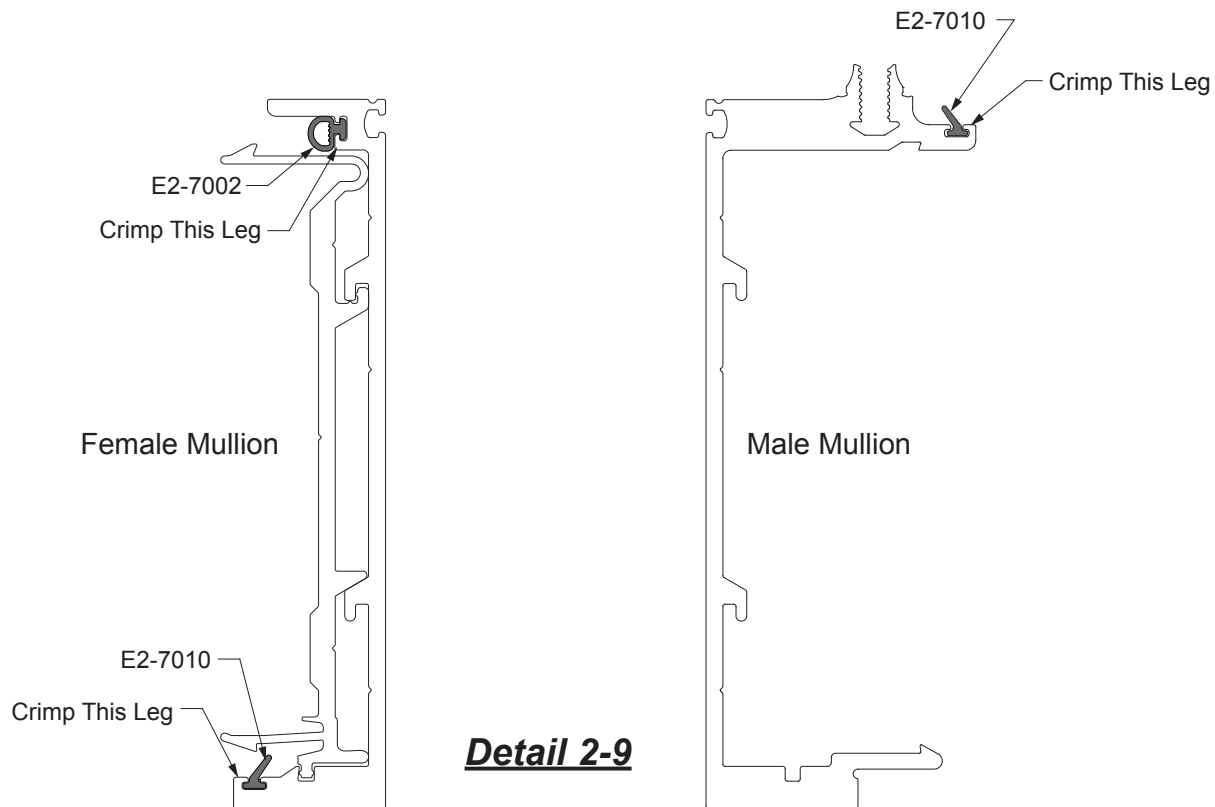

**STEP 3b
SEAL HORIZONTAL INTERSECTIONS**

-Refer to **CS1 Gasket Installation, Step 3b** on **Page 11**.

**STEP 3c
INSTALL INTERIOR GLAZING GASKETS**

-Refer to **CS1 Gasket Installation, Step 3c** on **Page 12**.

STEP 4: CS2 GLASS INSTALLATION

STEP 4a

INSTALL SETTING BLOCK CHAIRS AND SETTING BLOCKS

-Refer to **CS1 Glass Installation, Step 4a** on **Page 13**.

STEP 4b

INSTALL GLASS

-Refer to **CS1 Glass Installation, Step 4b** on **Page 14**.

STEP 4c

INSTALL THERMAL SHIELD

-Refer to **CS1 Glass Installation, Step 4c** on **Page 17**.

STEP 5: CS2 THERMAL BARRIER & WEATHERSEAL INSTALLATION

STEP 5a

INSTALL SSG THERMAL BARRIER & GASKET

-Refer to **CS1 Thermal Barrier & Cover Installation, Step 5b** on **Page 19**.

STEP 5b

INSTALL STACKING SILL WEATHER SEAL

-Refer to **CS1 Thermal Barrier & Cover Installation, Step 5c** on **Page 20**.

STEP 5: CS2 THERMAL BARRIER & WEATHERSEAL INSTALLATION

**STEP 5c
INSTALL STACKING TRAY ACCESSORIES**

- Slide in E2-3906 stack isolator into stacking tray as shown in **Detail 2-10**.
- Slide in E1-7001 stack joint plate at male mullion side. Secure stack joint plate with tape. Final stack joint plate adjustment will be made once the unit is installed on jobsite.
- Slide in E2-7004 air/water seal gasket positioned starting at 2" from the perimeter edge of female mullion and extending 6" beyond the male mullion as shown in **Detail 2-11**. Affix the gasket with a small amount of silicone.

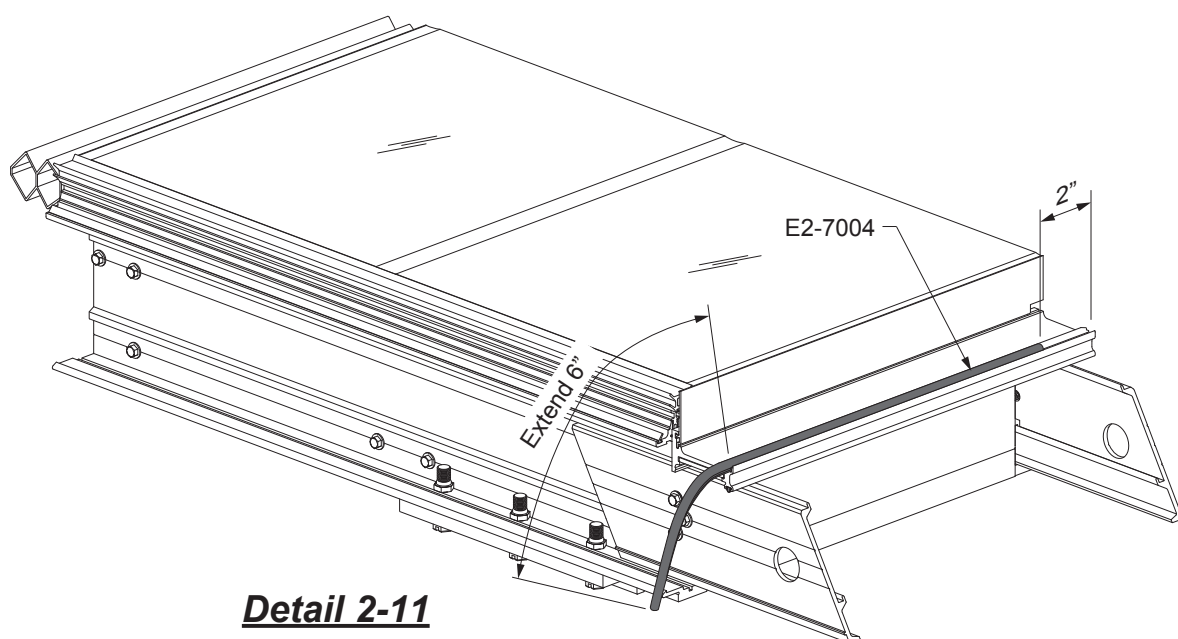
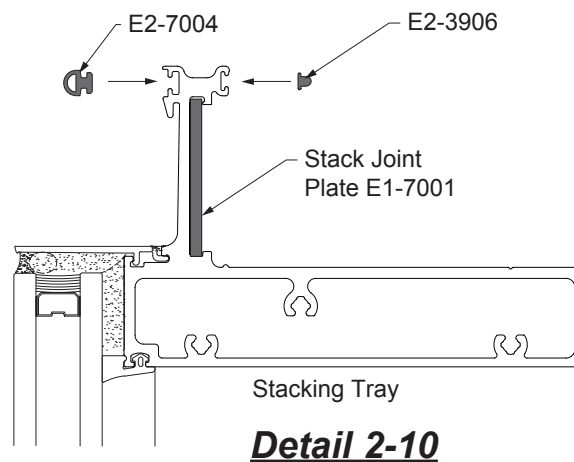

CS3 TABLE OF CONTENTS

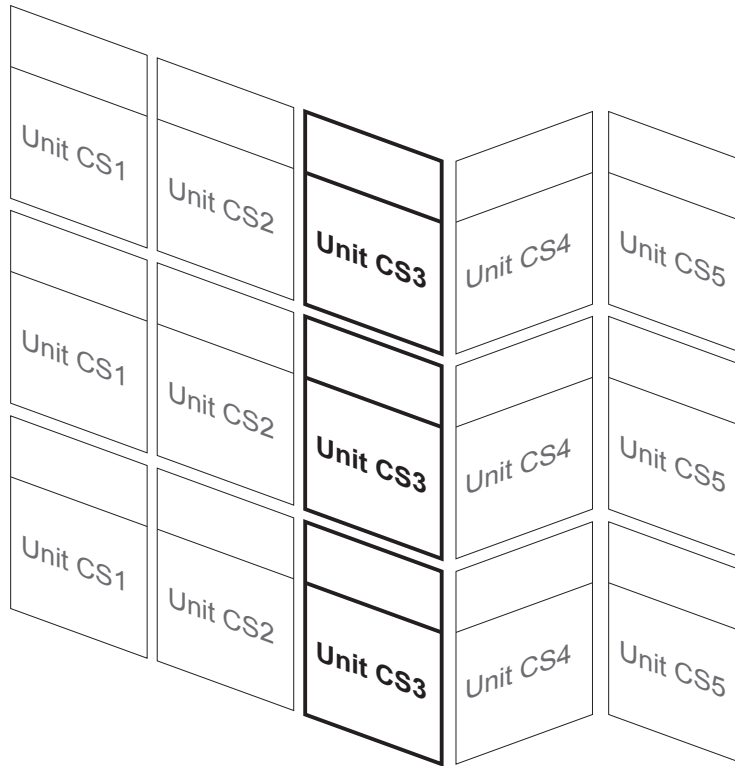

The following is intended for use as a guide for assembly of **Unit CS3** of the **YUW 750 XT 4-Sided SSG Curtain Wall System**. It is organized into five steps which will take you from assembly of parts to completed units.

Step 1: CS3 Unit Assembly	Pages 34 to 38
Step 2: CS3 Parts Installation	Pages 39 to 42
Step 3: CS3 Gasket Installation	Pages 43 & 44
Step 4: CS3 Glass Installation	Pages 45 to 49
Step 5: CS3 Thermal Barrier & Weatherseal Installation.....	Pages 50 & 51

Care should be taken to ensure you have inventory of all items required to complete this assembly. We recommend you refer to the parts list (pages iv - viii) as a reference and compare it to your specific project to ensure you have all the correct parts and tools required to complete the assembly.

STEP 1: CS3 UNIT ASSEMBLY

MAJOR COMPONENTS

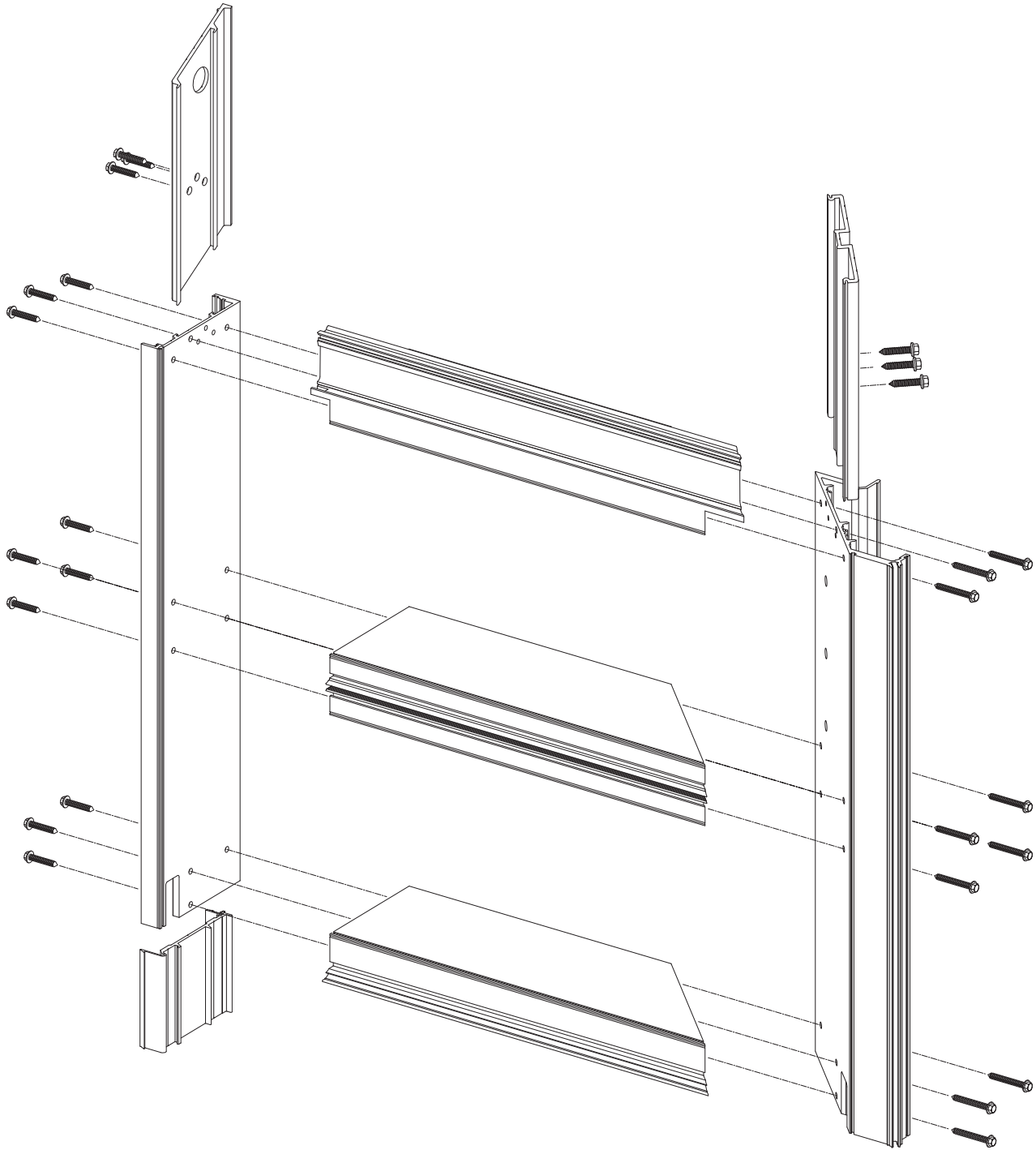

STEP 1: CS3 UNIT ASSEMBLY

STEP 1a

APPLY SEALANT TO FRAMING MEMBERS

-Clean, prime and apply sealant to both ends of horizontals and tops of verticals per typical unit detail and approved shop drawings.

See **Detail 3-1**.

Stacking Tray: seal at the front wall and bottom wall back to 1st screw spline.

Intermediate Horizontals: seal at the front of tube back to 1st screw spline.

Stacking Sill: seal at the front leg, 1" back along top of sill.

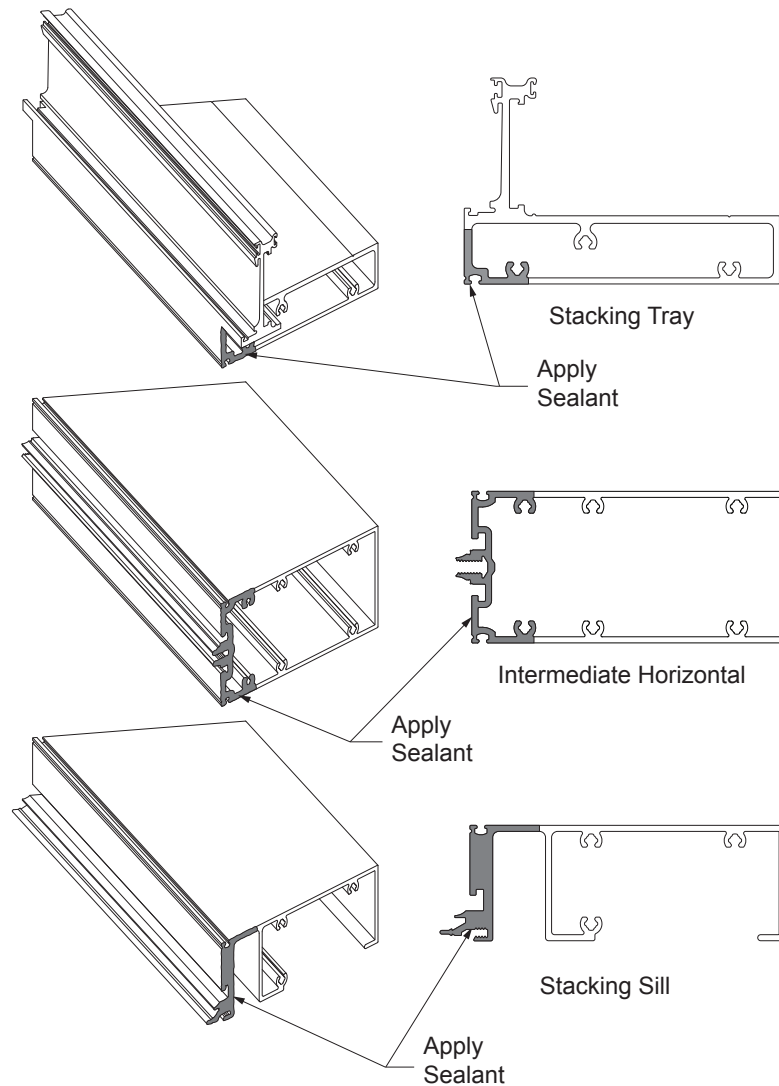

Detail 3-1

STEP 1: CS3 UNIT ASSEMBLY

**STEP 1a (Continued)
APPLY SEALANT TO FRAMING MEMBERS**

Vertical Mullions: seal top of female mullion and male corner mullion as shown in **Detail 3-2**.

Note: Apply sealant in groove from the bottom of the male mullion up 4" minimum as shown on **Detail 3-3** and tool flush.

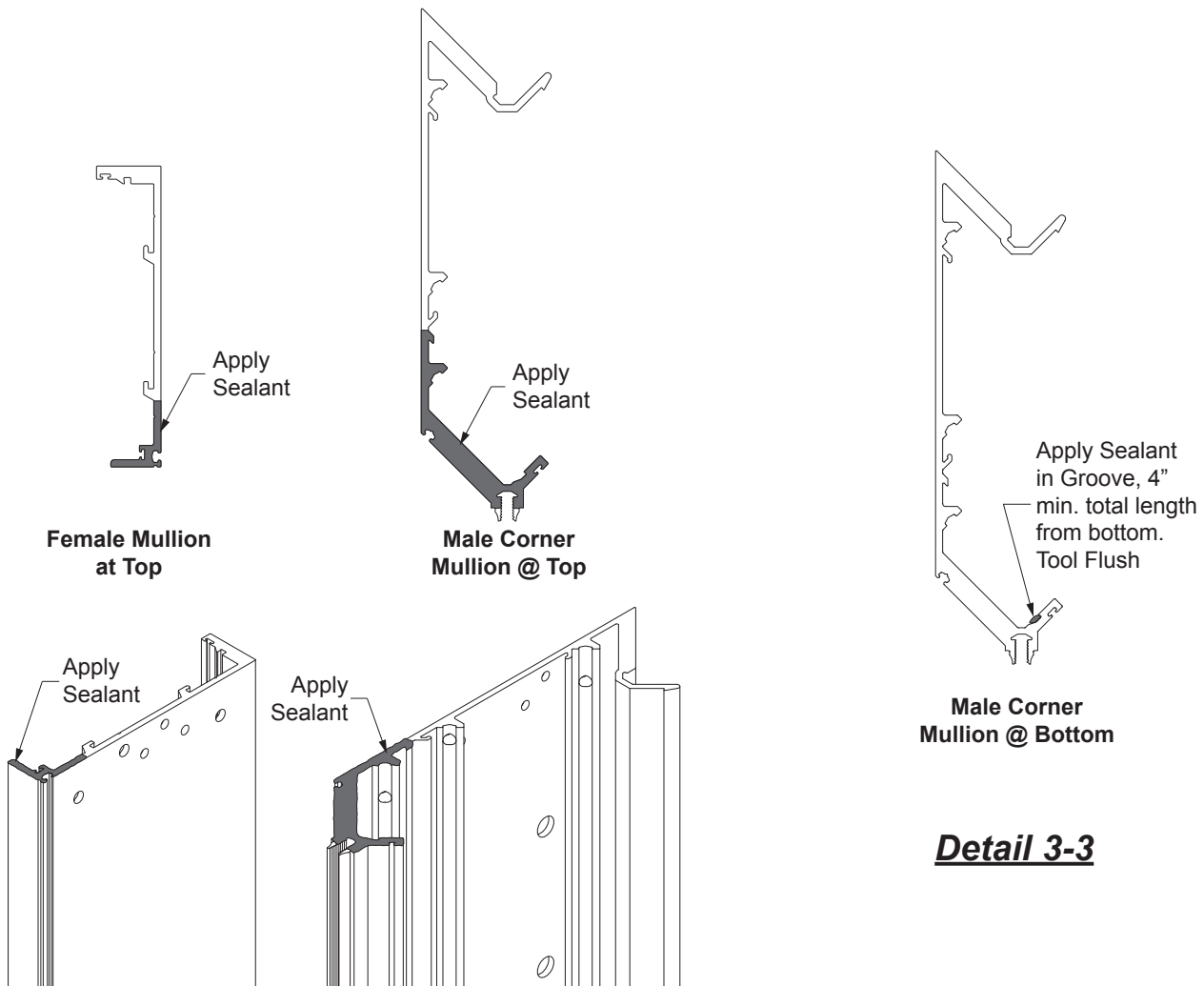

Detail 3-2

Detail 3-3

STEP 1: CS3 UNIT ASSEMBLY

STEP 1b

ATTACH VERTICAL MULLIONS TO HORIZONTALS

-Position horizontal members aligning splines with screw holes in the female mullion and assemble with HC-1220-SS fasteners as shown in **Detail 3-4**. Wipe off excess sealant.

Note: Take care to keep sealant from getting into gasket raceways, setting block chair pockets and around stems.

-Tool all excess sealant flush.

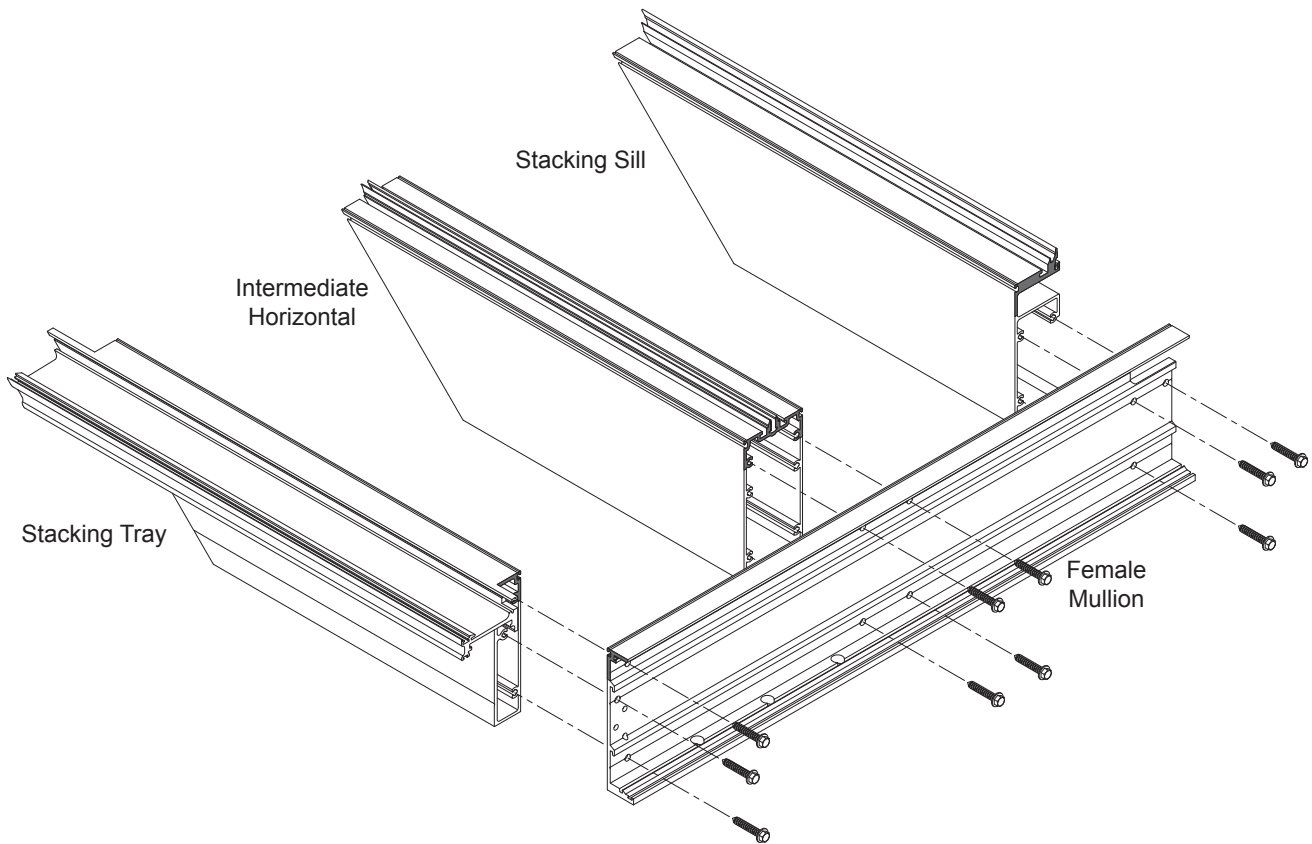

Detail 3-4

STEP 1: CS3 UNIT ASSEMBLY**STEP 1b (Continued)****ATTACH VERTICAL MULLIONS TO HORIZONTALS**

-Position horizontal members aligning splines with screw holes in the outside corner male mullion and assemble with HC-1228-SS fasteners as shown in **Detail 3-5**. Wipe off excess sealant.

Note: Take care to keep sealant from getting into gasket raceways, setting block chair pockets and around stems.

-Tool all excess sealant flush.

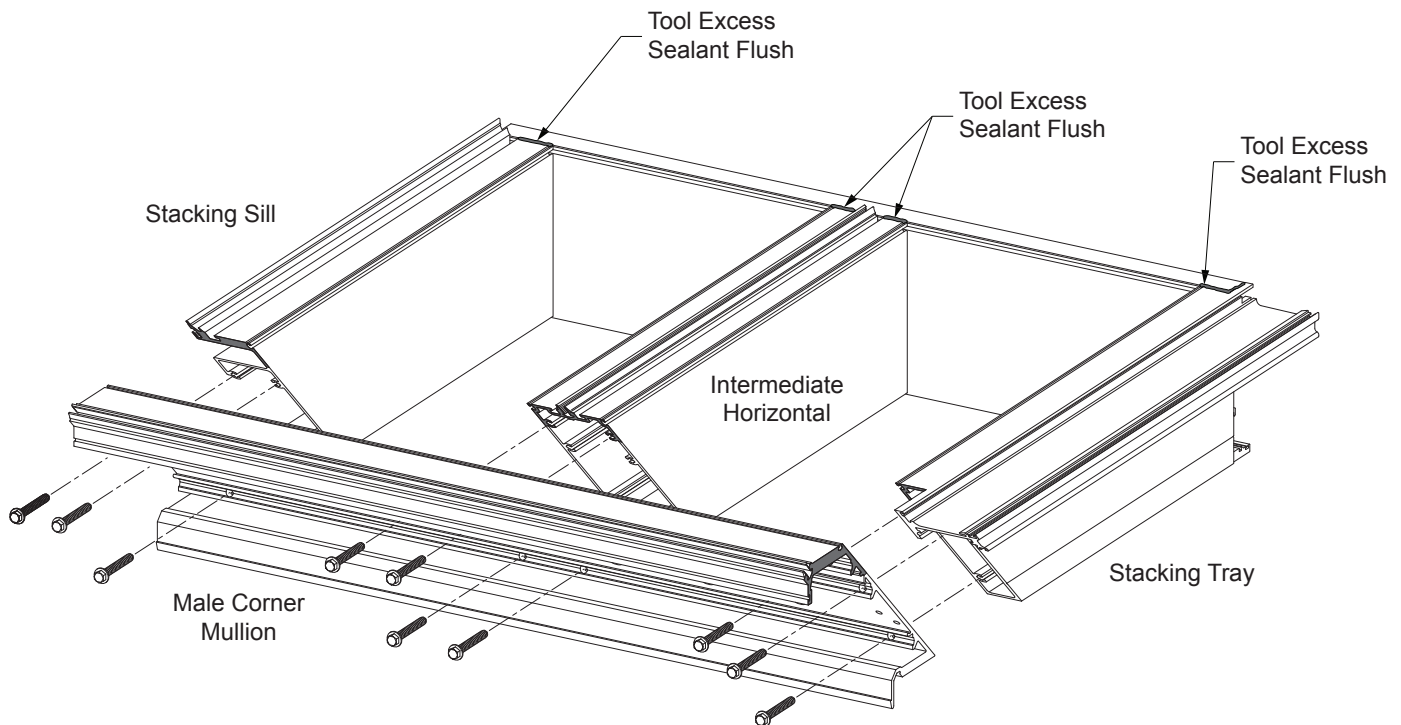

Detail 3-5

STEP 2: CS3 PARTS INSTALLATION

STEP 2a

INSTALL MULLION SLEEVES AND LEVELING ANCHORS

-Using HD-2520-W3 fasteners, install the mullion sleeves as shown in **Detail 3-6**, unless noted otherwise on the approved shop drawings.

Note: HD-2520-W3 fasteners (3 shown per sleeve) are sufficient for units weighing up to 2,350 lbs. Units weighing beyond that will require modifications to the anchor and/or fasteners.

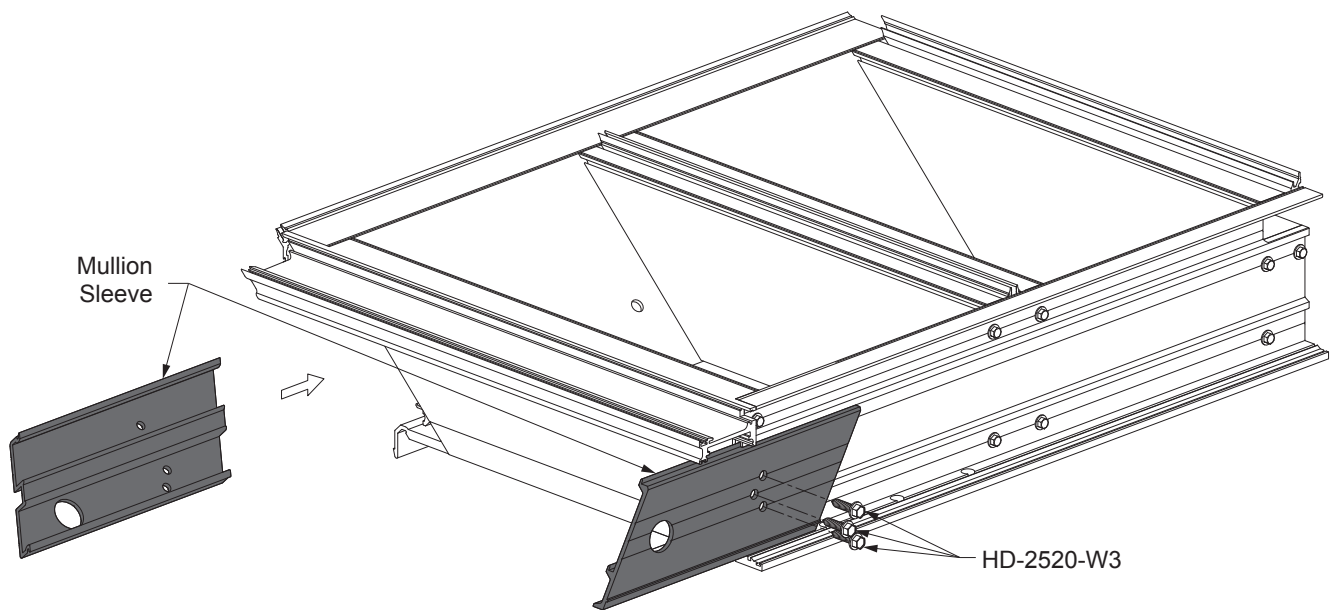

Detail 3-6

STEP 2: CS3 PARTS INSTALLATION**STEP 2a (Continued)****INSTALL MULLION SLEEVES AND LEVELING ANCHORS**

-Place blocks at all four corners of the unit to keep the leveling anchors from coming into contact with the work table and also to maintain a level working surface. Install leveling the anchors for the female mullionu using fasteners as shown in **Detail 3-7**. Refer to shop drawings for leveling bracket locations.

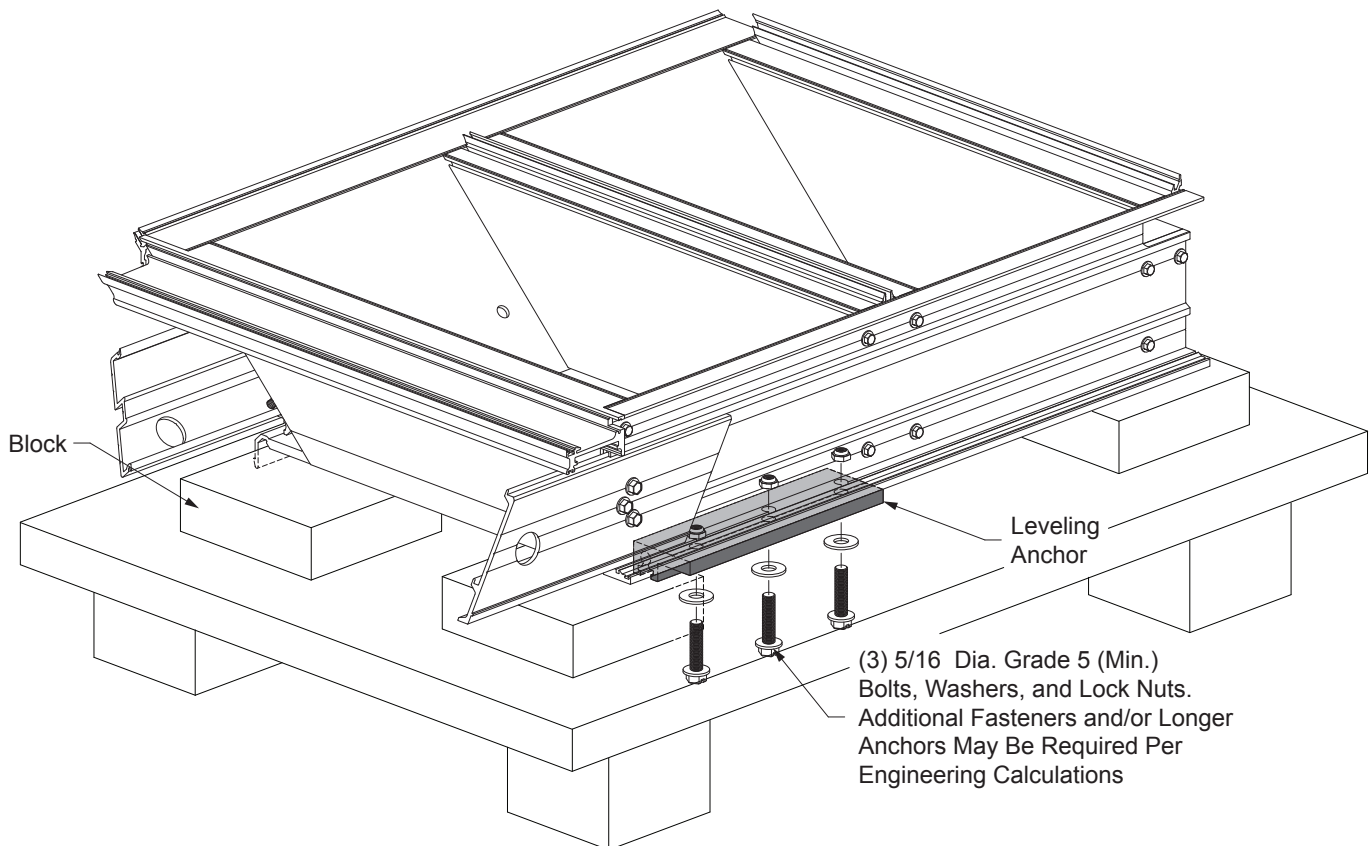
**Detail 3-7**

-The outside corner male mullion requires 3/8" diameter bolts, washers, and lock nuts. Install them as shown in **Detail 3-8** on **Page 41**.

STEP 2: CS3 PARTS INSTALLATION

STEP 2a (Continued)

INSTALL MULLION SLEEVES AND LEVELING ANCHORS

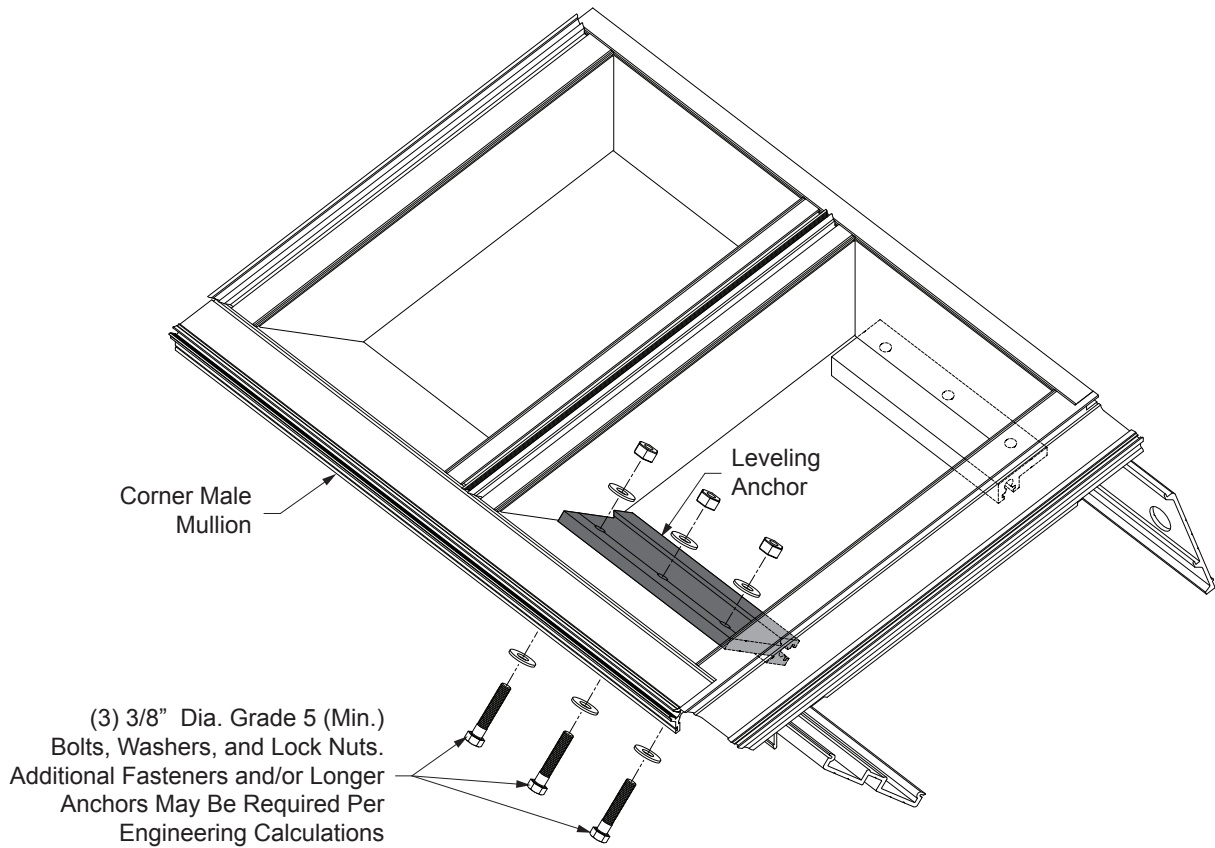

Detail 3-8

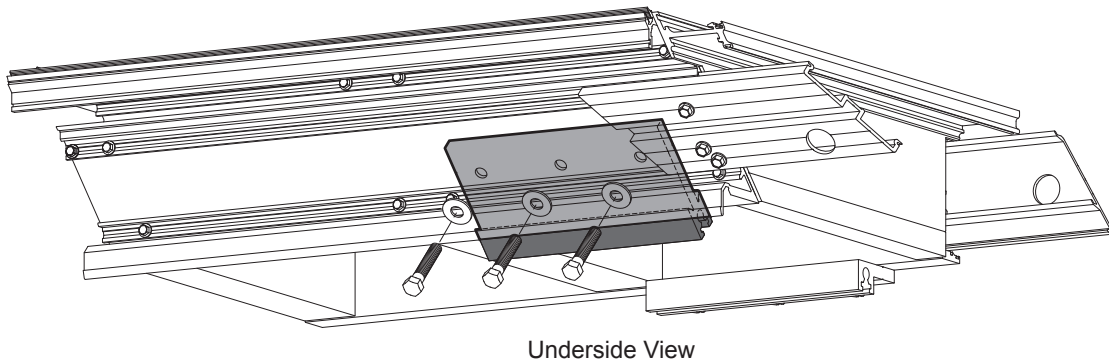

STEP 2: CS3 PARTS INSTALLATION**STEP 2b****INSTALL MULLION INTERLOCKING CLIPS**

-Refer to **CS2 Parts Installation, Step 2b** on **Page 28**.

STEP 2c**INSTALL STEEL REINFORCING (If Required)**

-Install steel or aluminum reinforcing as required to the mullions per approved shop drawings.
Shim and fasten as required. Coordinate installation of steel with anchor lug backup.

See **Detail 3-9**.

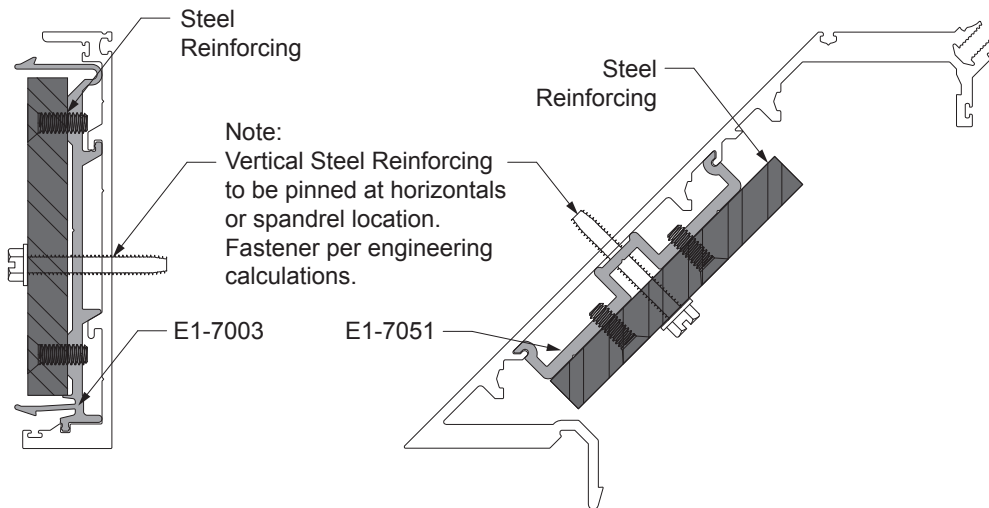

Detail 3-9

STEP 3: CS3 GASKET INSTALLATION

**STEP 3a
INSTALL WEATHER SEAL GASKETS**

- Slide in weather seal gasket at the outer leg gasket raceway of the corner male mullion and into the inner leg gasket raceway of the female mullion as shown in **Detail 3-10**.
- Slide in the air water seal gasket at the outer leg gasket raceway of the female mullion.
- Crimp raceway at both ends of mullion by deforming the retaining leg of the gasket raceway in order to keep the gasket from sliding out during unit installation. Gaskets to run full length of mullion.

Note: Weather seal gasket is handed. Install gasket in the orientation as shown below.

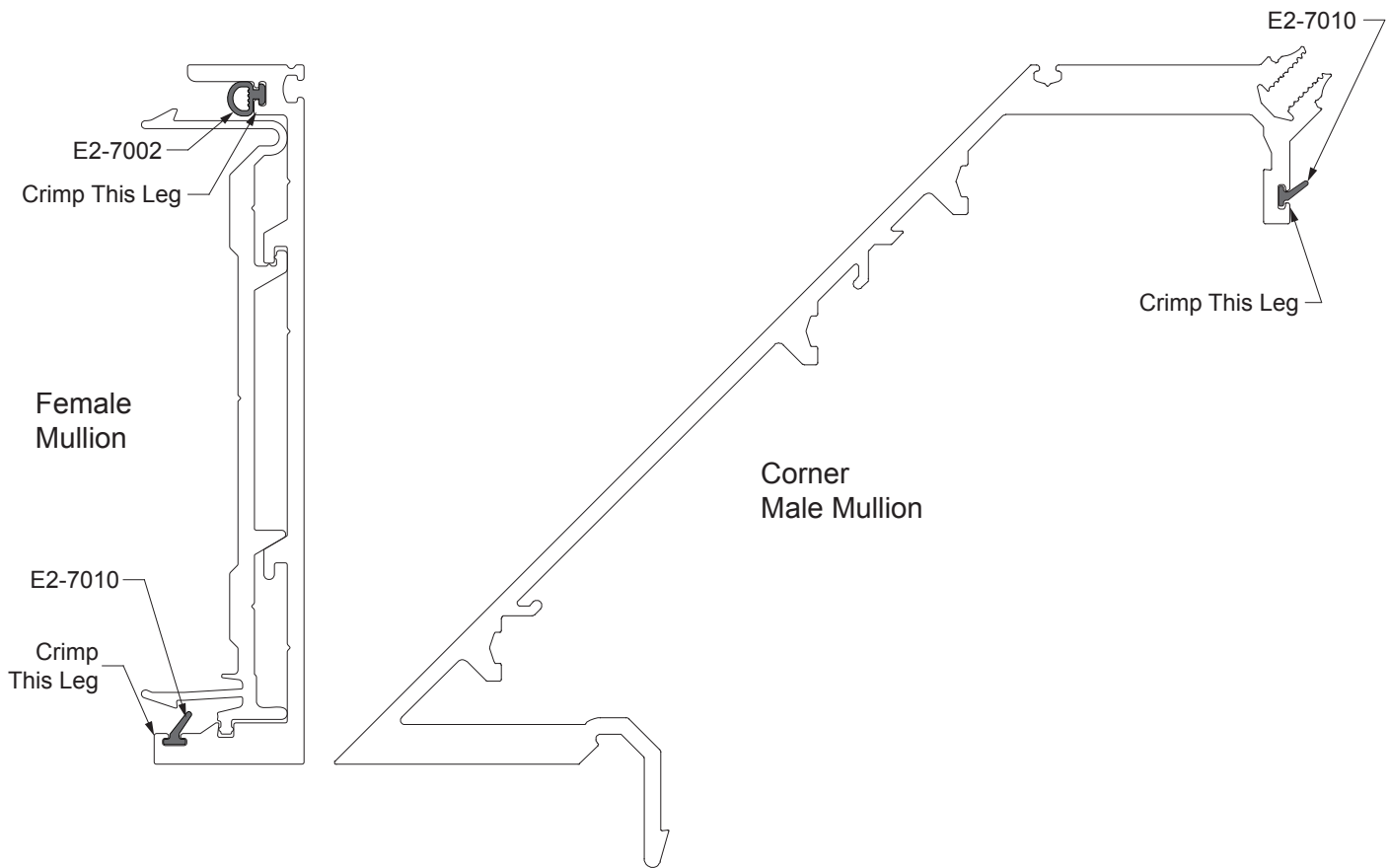

Detail 3-10

**STEP 3b
SEAL HORIZONTAL INTERSECTIONS**

-Refer to **CS1 Gasket Installation, Step 3b** on **Page 11**.

STEP 3: CS3 GASKET INSTALLATION

**STEP 3c
INSTALL INTERIOR GLAZING GASKETS**

-Secure the assembled unit to a flat surface with the exterior facing up. Table must be flat and level, and must support frame at all locations. A unit glazed with any mullion deflection will cause installation problems. Additional bracing under the glass may be required with large glass lites to prevent glass deflection.

-Clean and prepare glass and aluminum surfaces in strict conformity with sealant manufacturer's specifications and requirements.

-Install E2-7001 interior gasket on all horizontals and the female mullion. Install E2-7014 spacer on the corner mullion. Both female and horizontal gaskets are to be cut to D.L.O. Corner spacer is to be cut to D.L.O. + 1-1/2". Vertical gaskets are to be installed first, followed by the horizontal gaskets.

See **Detail 3-11**.

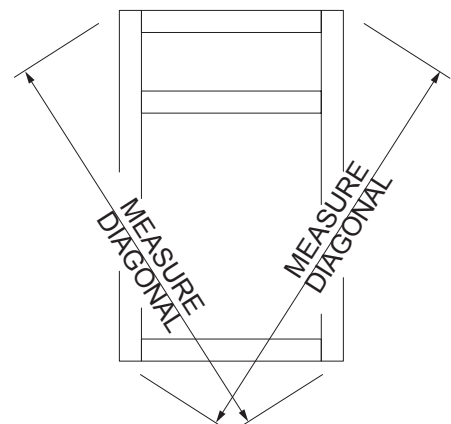
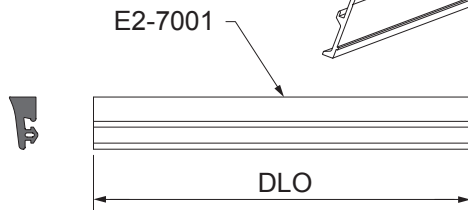
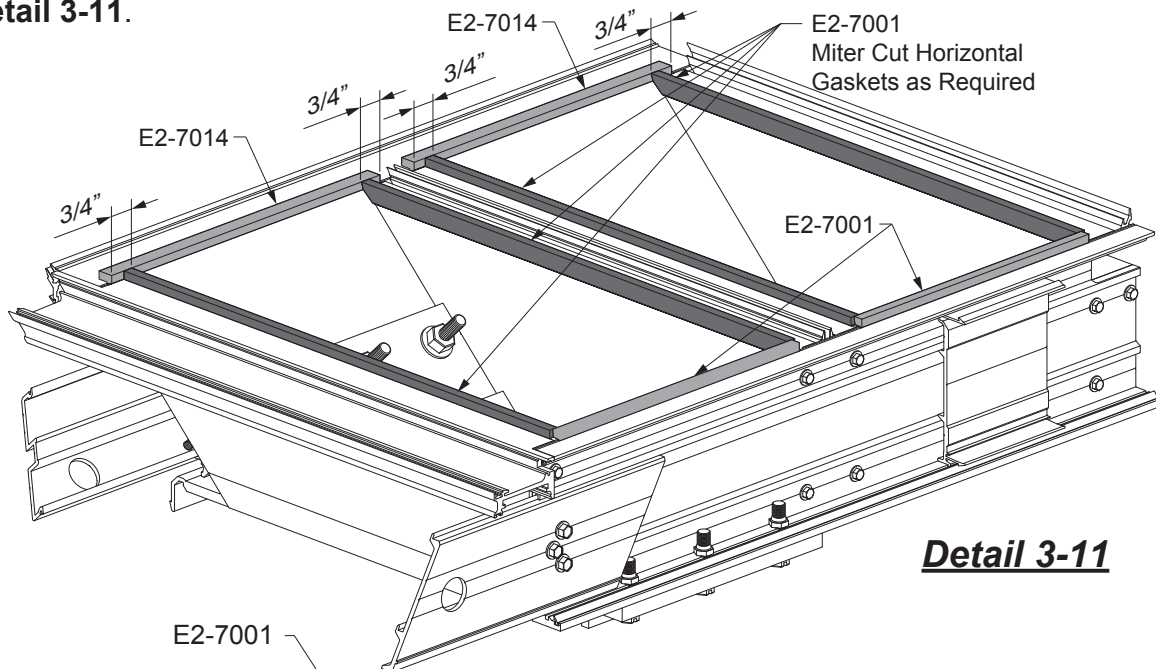

Note:
Before installing the glass, double-check squareness of frame by measuring diagonals. The maximum difference between diagonals is 1/16". Sight down mullions to make sure unit is not bowed. A unit glazed in a "out of square" or "bowed" position will cause installation problems.

STEP 4: CS3 GLASS INSTALLATION

STEP 4a

INSTALL SETTING BLOCK CHAIRS AND SETTING BLOCKS

-Apply setting block chairs and temporarily apply setting blocks oriented outward on setting block chairs placed at 1/4 points of horizontals as shown in **Detail 3-12**.

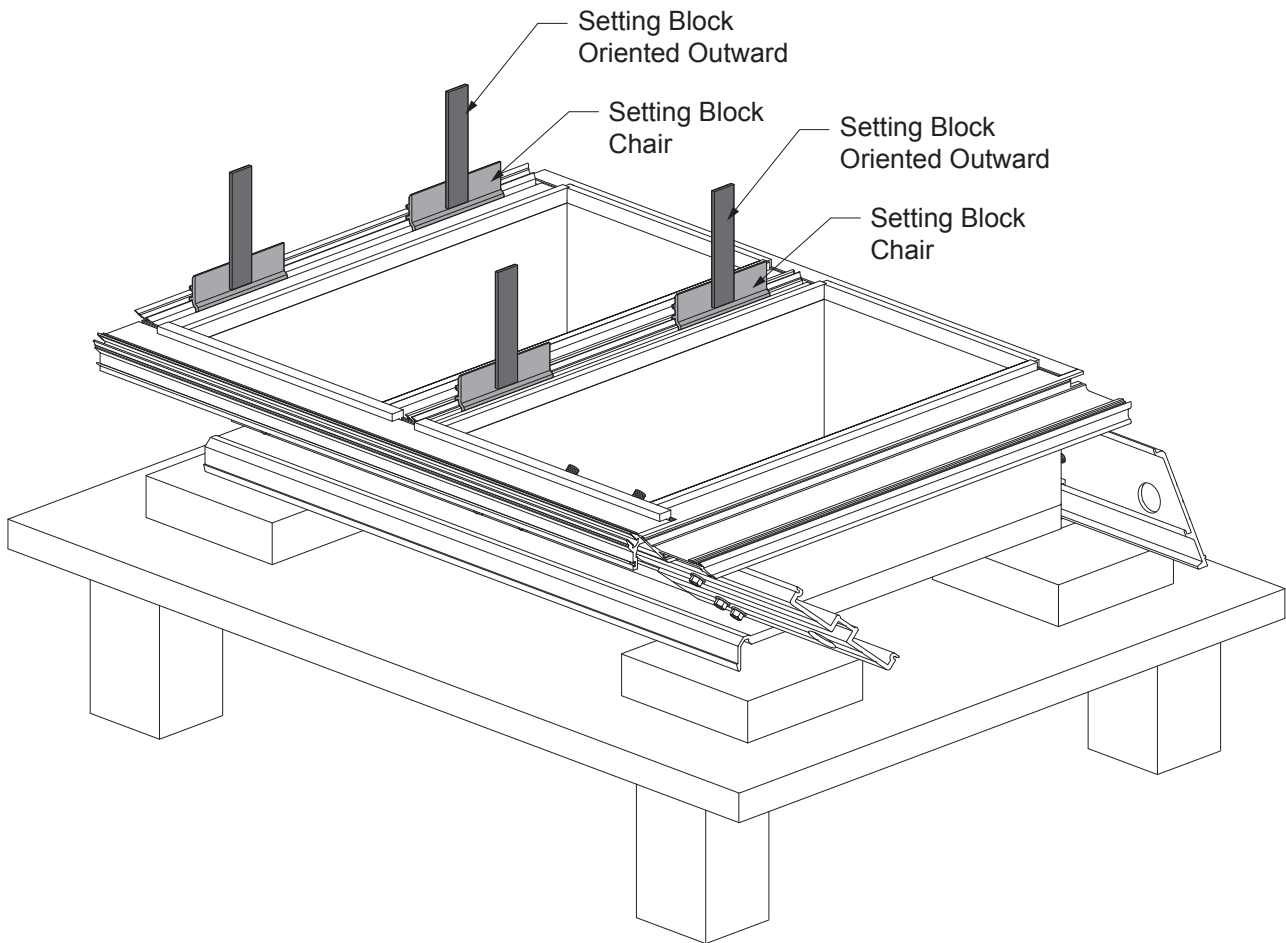

Detail 3-12

STEP 4: CS3 GLASS INSTALLATION

**STEP 4b
INSTALL GLASS**

- Position the glass laterally in the D.L.O. as shown in Detail 3-13.
- Install glass by placing bottom edge against both setting blocks and lower into place.
- When glass is properly positioned, remove setting blocks. Take caution to not move glass during setting block removal.
- Reference shop details and glazing details for non typical conditions.

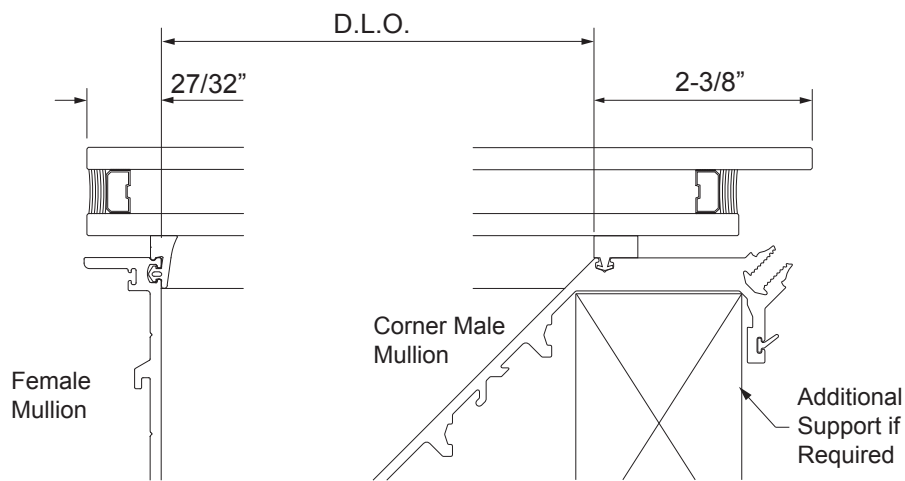

Detail 3-13

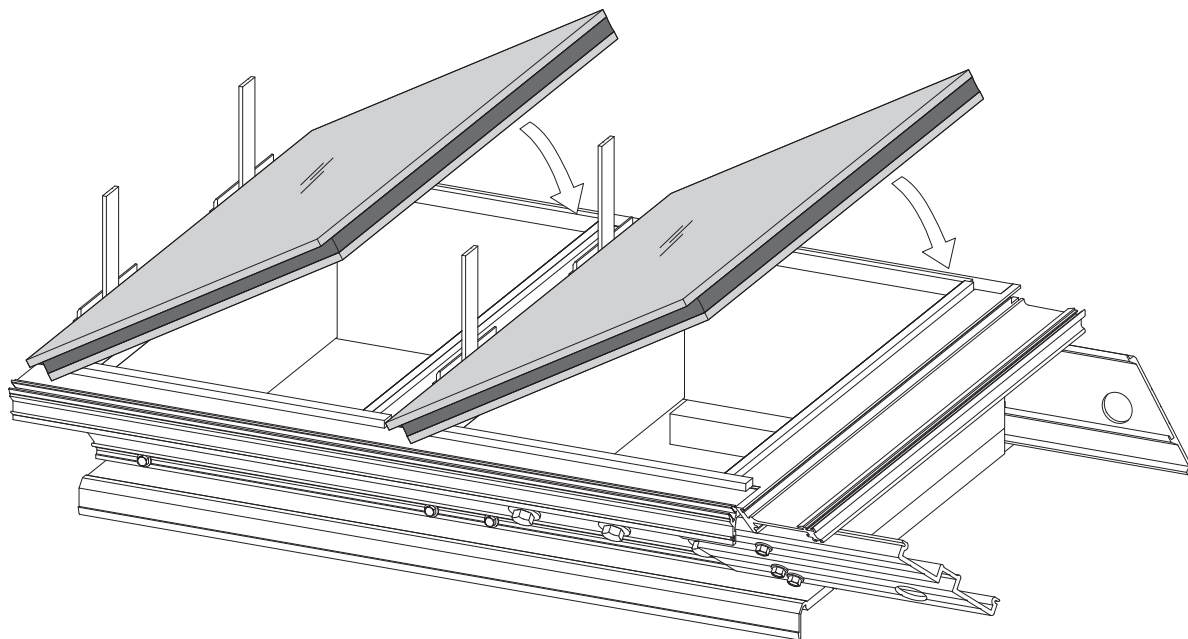

STEP 4: CS3 GLASS INSTALLATION

STEP 4b (Continued) INSTALL GLASS

- Ensure that the glass and metal surfaces are clean and prepared per sealant manufacturer's specifications and recommendations.
- Apply structural silicone sealant completely filling the space between the glass and the mullion. (Slide setting block chairs out of the way temporarily while sealing units.)
- Tool sealant. Clean out any excess sealant in horizontal groove and engagement areas.

See **Detail 3-14**.

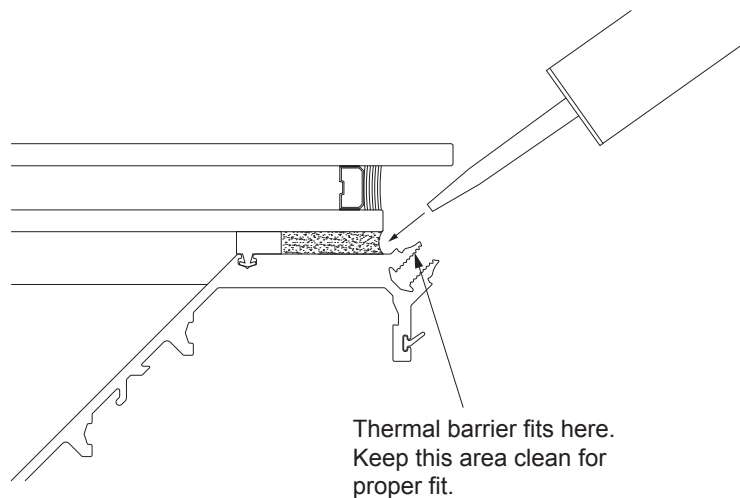

Detail 3-14

STEP 4: CS3 GLASS INSTALLATION

**STEP 4b (Continued)
INSTALL GLASS**

-Apply silicone in I.G.U. cap trace. Rotate and hook in E3-7002 I.G.U. cap. Apply flush with the perimeter edge of the jamb. Tool sealant flush with top of I.G.U. cap.

See **Detail 3-15**.

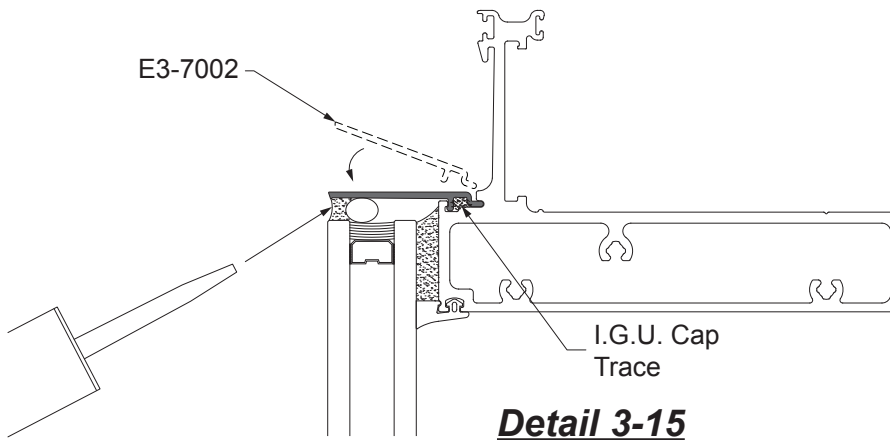

-Push in 3/8" backer rod and seal around the glass and under the I.G.U. cap as shown in **Detail 3-16**. Tool sealant.

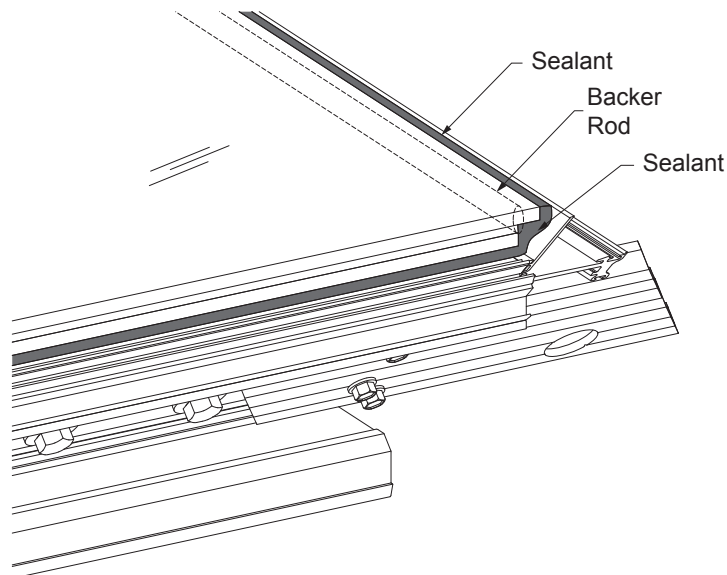

STEP 4: CS3 GLASS INSTALLATION

STEP 4c

INSTALL THERMAL SHIELD

- Before installing the thermal shield, apply a few dabs of sealant to keep it in place.
 - Snap thermal shield into the front of the stacking sill, centered on the D.L.O. See **Detail 3-17**.
 - Install backer rods to the joint and completely fill intermediate horizontal and stacking sill joints with sealant as shown on **Detail 3-18**.
- Tool excess sealant to ensure a complete seal. Be sure to keep sealant out of horizontal groove and engagement areas.

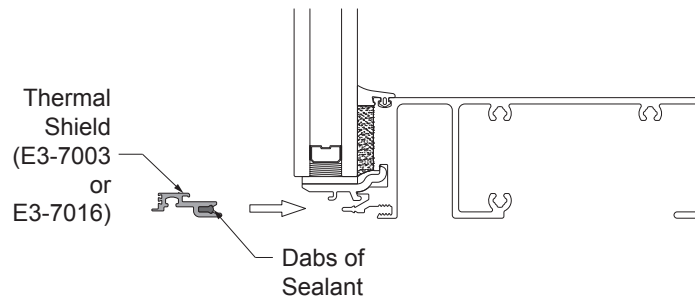

Detail 3-17

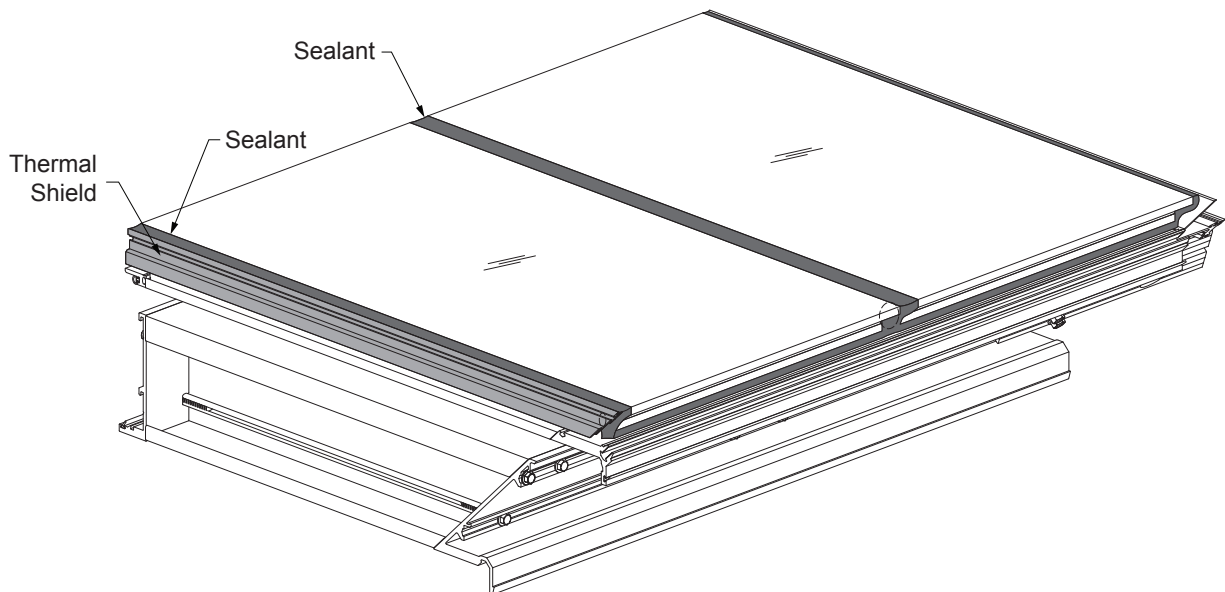

Detail 3-18

STEP 5: CS3 THERMAL BARRIER & WEATHERSEAL INSTALLATION

STEP 5a

INSTALL SSG THERMAL BARRIER & GASKET

- Snap in SSG Thermal Barrier into the corner mullion raceway.
- Push in the SSG Wiper Gasket E2-7015 into the SSG thermal barrier. Align according to unit module.

See **Detail 3-19**.

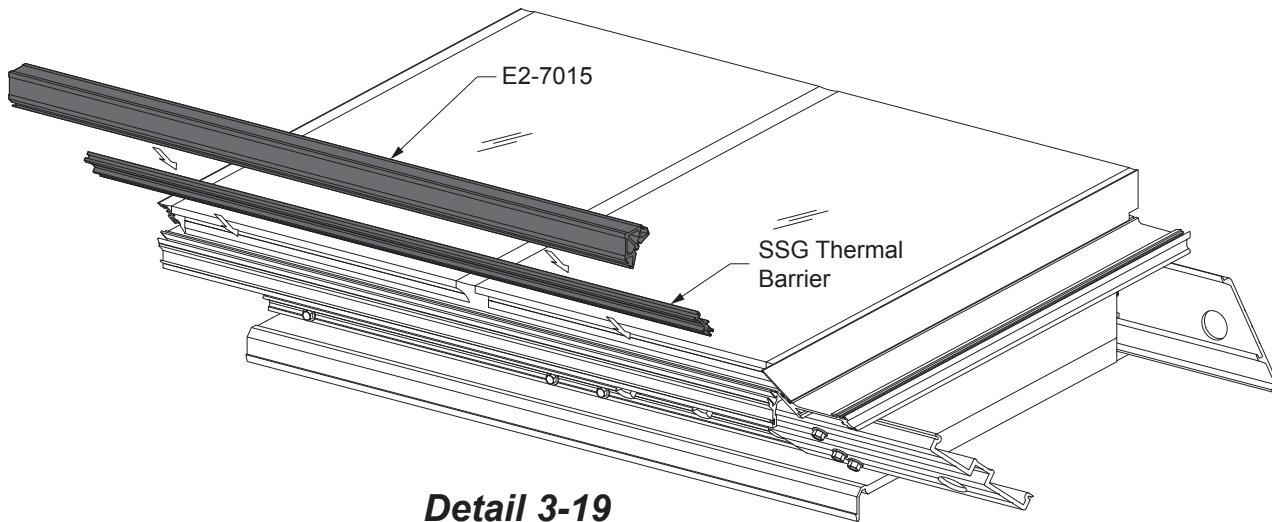

Detail 3-19

- Apply a dab of sealant at both ends of the gasket and thermal barrier to hold them in place.

See **Detail 3-20**.

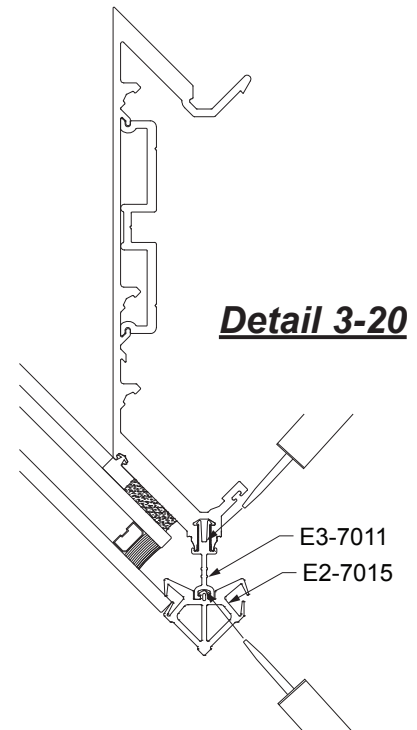

Detail 3-20

STEP 5b

INSTALL STACKING SILL WEATHER SEAL

- Refer to **CS1 Thermal Barrier & Cover Installation, Step 5c on Page 20**.

STEP 5: CS3 THERMAL BARRIER & COVER INSTALLATION

STEP 5c

INSTALL STACKING TRAY ACCESSORIES

- Slide in E2-3906 stack isolator into stacking tray as shown in **Detail 3-21**.
- Slide in E2-7004 air/water seal gasket positioned starting at 2" from the perimeter edge of the female mullion and extending 6" beyond the corner male mullion as shown in **Detail 3-22**. Affix the gasket with a small amount of silicone.

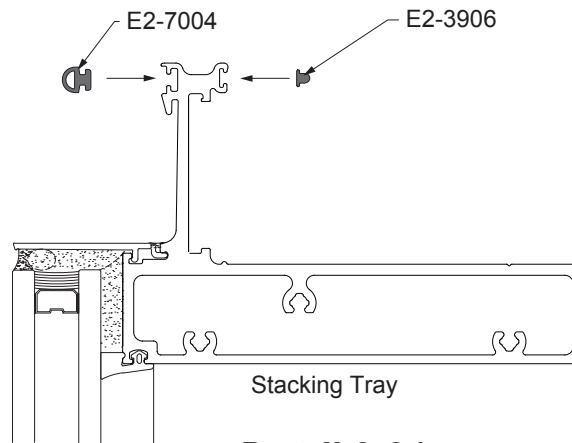

Detail 3-21

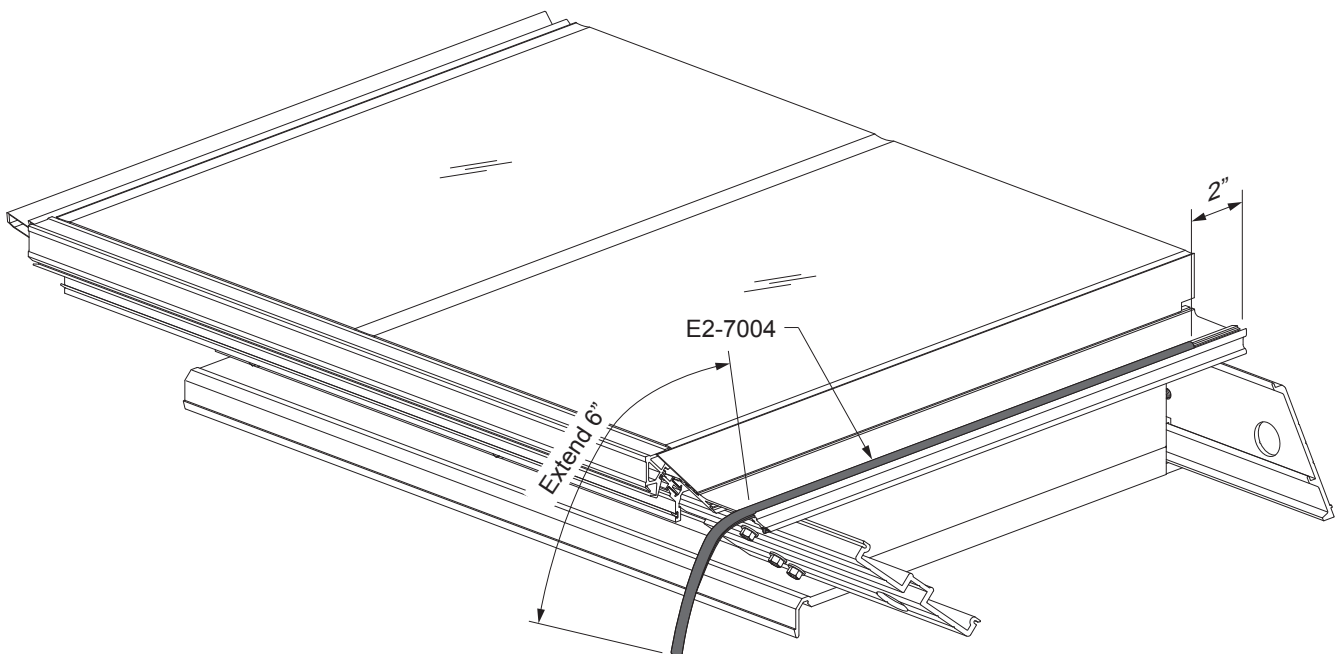

Detail 3-22

CS4 TABLE OF CONTENTS

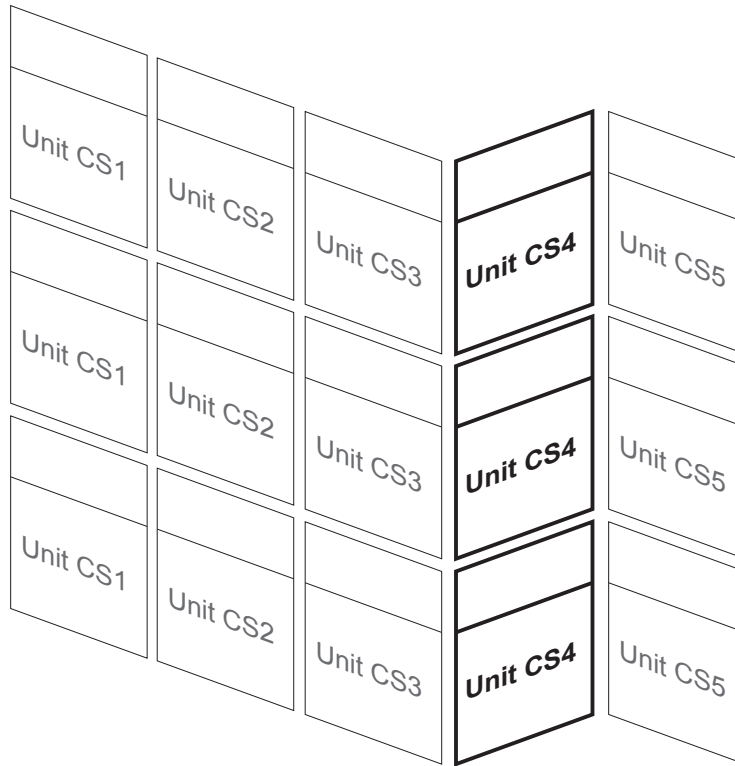

The following is intended for use as a guide for assembly of **Unit CS4** of the **YUW 750 XT 4-Sided SSG Curtain Wall System**. It is organized into five steps which will take you from assembly of parts to completed units.

Step 1: CS4 Unit Assembly	Pages 53 to 57
Step 2: CS4 Parts Installation	Pages 58 to 61
Step 3: CS4 Gasket Installation	Pages 62 & 63
Step 4: CS4 Glass Installation	Pages 64 to 68
Step 5: CS4 Thermal Barrier & Weatherseal Installation.....	Pages 69 & 70

Care should be taken to ensure you have inventory of all items required to complete this assembly. We recommend you refer to the parts list (pages iv - viii) as a reference and compare it to your specific project to ensure you have all the correct parts and tools required to complete the assembly.

STEP 1: CS4 UNIT ASSEMBLY

MAJOR COMPONENTS

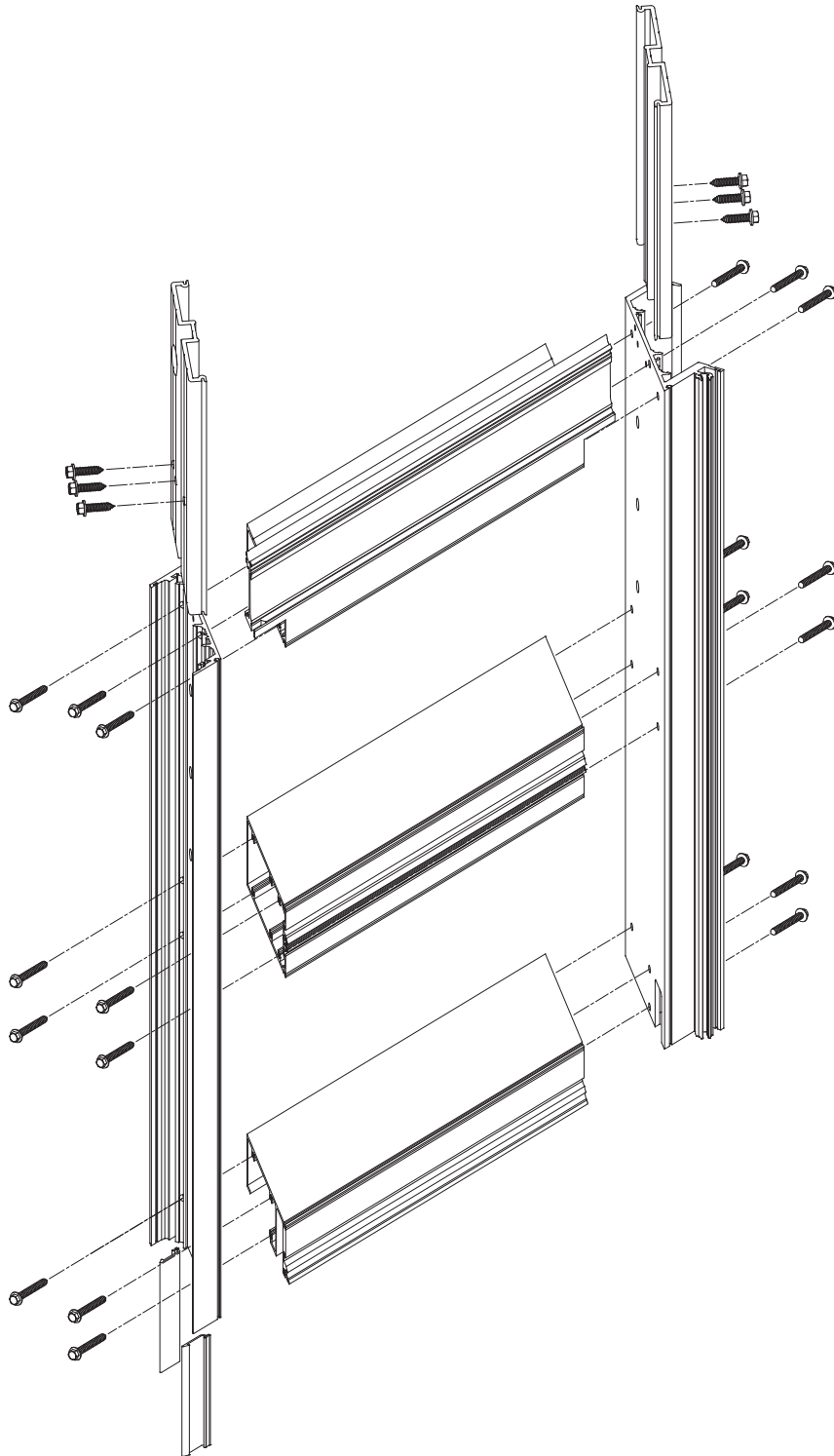

STEP 1: CS4 UNIT ASSEMBLY

**STEP 1a
APPLY SEALANT TO FRAMING MEMBERS**

-Clean, prime and apply sealant to both ends of horizontals and tops of verticals per typical unit detail and approved shop drawings.

See **Detail 4-1**.

Stacking Tray: seal at the front wall and bottom wall back to 1st screw spline.

Intermediate Horizontals: seal at the front of tube back to 1st screw spline.

Stacking Sill: seal at the front leg, 1" back along top of sill.

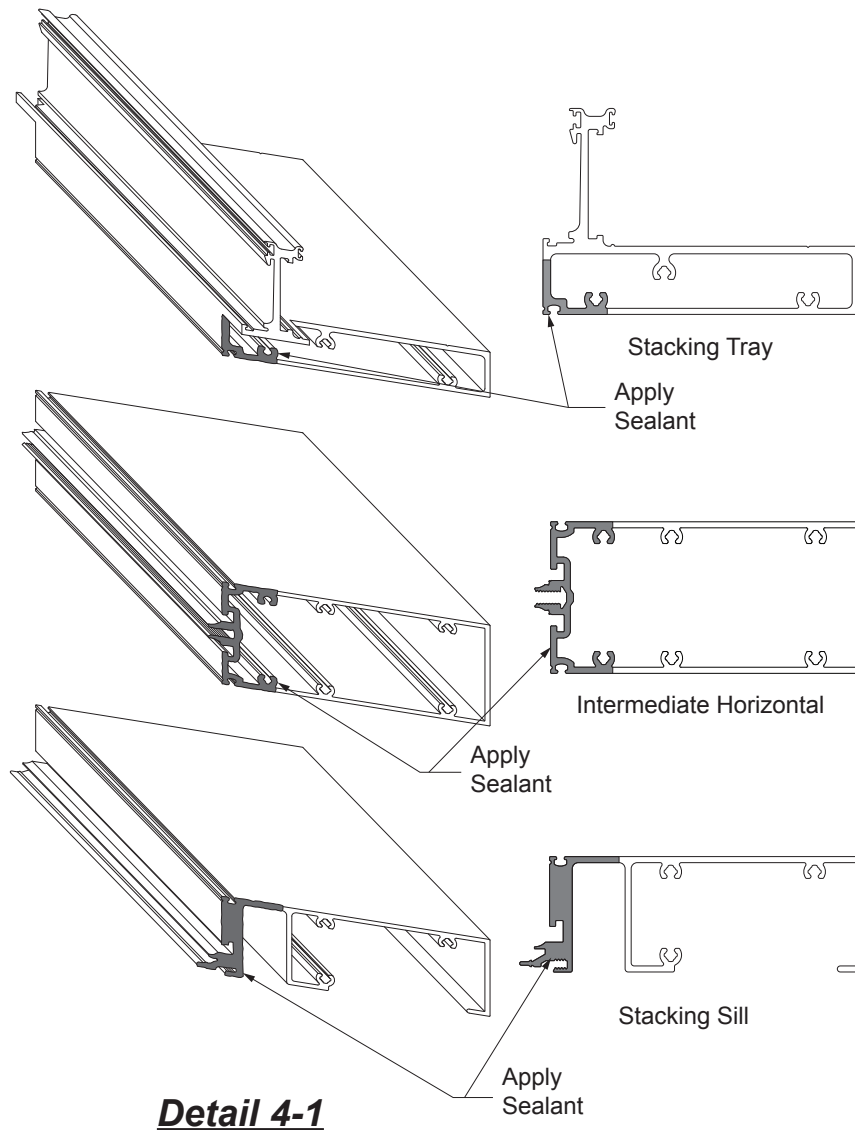

STEP 1: CS4 UNIT ASSEMBLY

STEP 1a (Continued)

APPLY SEALANT TO FRAMING MEMBERS

Vertical Mullions: seal top of outside corner female mullion and inside corner male mullion as shown in **Detail 4-2**.

Note: Apply sealant in groove from the bottom of the inside male corner mullion up 4" minimum and tool flush. See **Detail 4-3**.

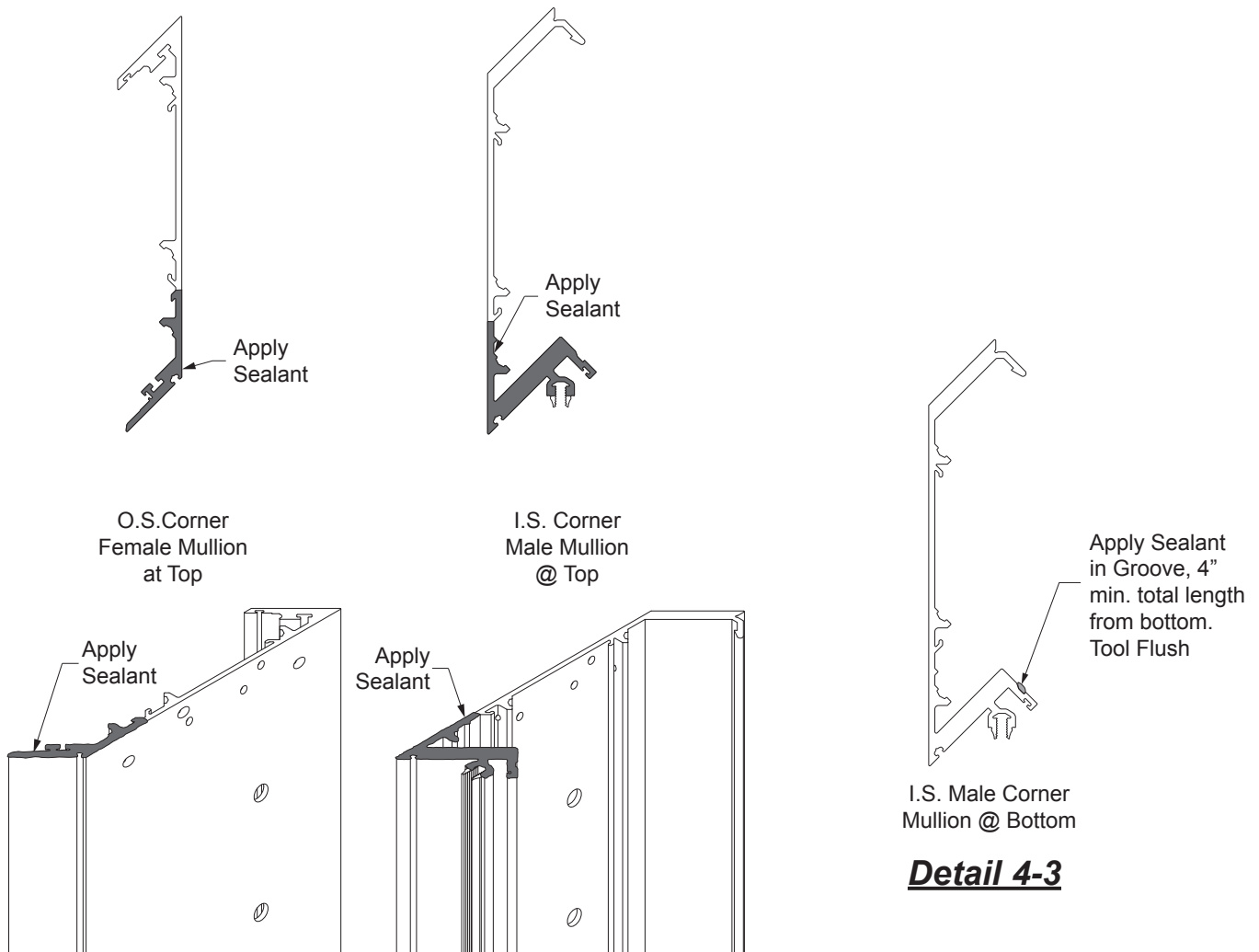

Detail 4-2

Detail 4-3

STEP 1: CS4 UNIT ASSEMBLY

**STEP 1b
ATTACH VERTICAL MULLIONS TO HORIZONTALS**

-Position horizontal members aligning splines with screw holes in the outside corner female mullion and assemble with HC-1228-SS fasteners as shown in **Detail 4-4**. Wipe off excess sealant.

Note: Take care to keep sealant from getting into gasket raceways, setting block chair pockets and around stems.

-Tool all excess sealant flush.

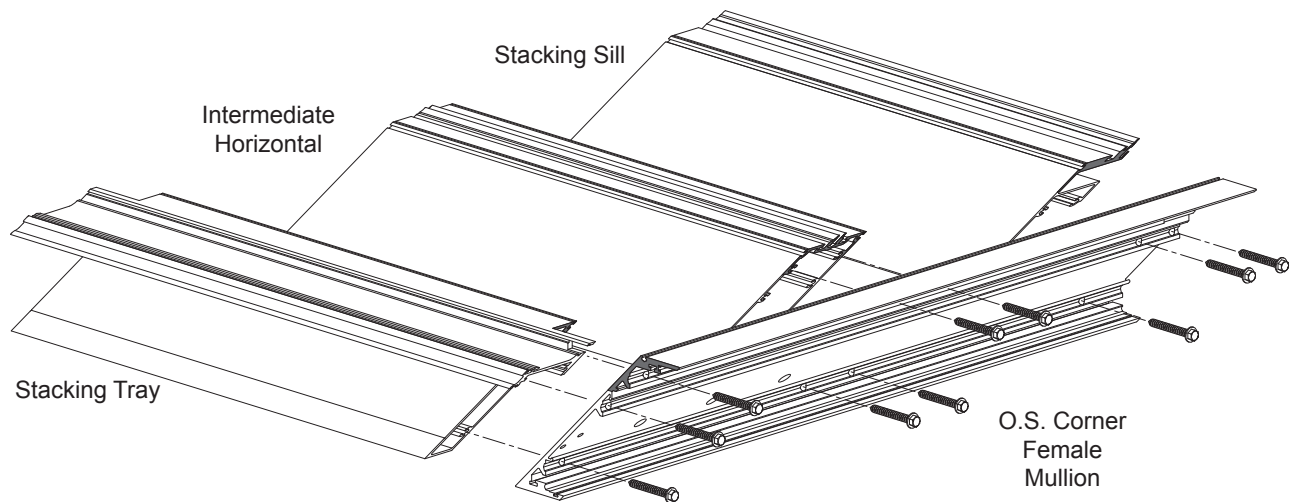

Detail 4-4

STEP 1: CS4 UNIT ASSEMBLY

STEP 1b (Continued)

ATTACH VERTICAL MULLIONS TO HORIZONTALS

-Position horizontal members aligning splines with screw holes in the inside corner male mullion and assemble with HC-1228-SS fasteners as shown in **Detail 4-5**. Wipe off excess sealant.

Note: Take care to keep sealant from getting into gasket raceways, setting block chair pockets and around stems.

-Tool all excess sealant flush.

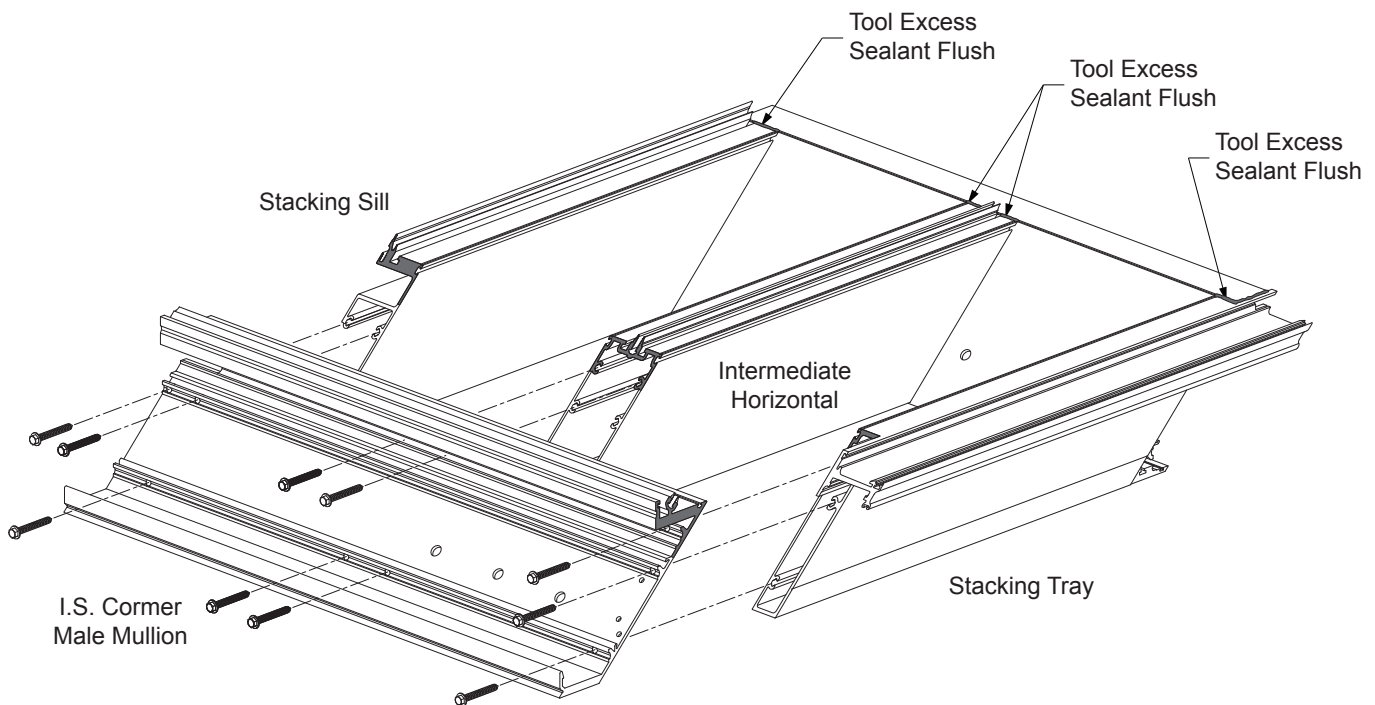

Detail 4-5

STEP 2: CS4 PARTS INSTALLATION

STEP 2a

INSTALL MULLION SLEEVES AND LEVELING ANCHORS

-Using HD-2520-W3 fasteners, install the mullion sleeves as shown in **Detail 4-6**, unless noted otherwise on the approved shop drawings.

Note: HD-2520-W3 fasteners (3 shown per sleeve) are sufficient for units weighing up to 2,350 lbs. Units weighing beyond that will require modifications to the anchor and/or fasteners.

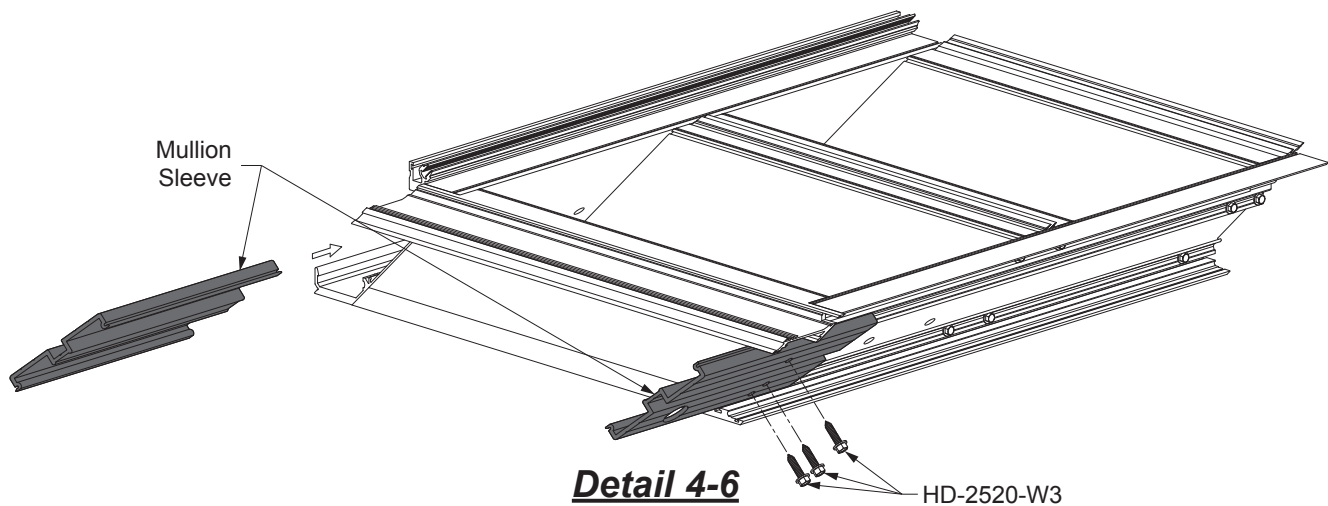

INSTALL MULLION SLEEVES AND LEVELING ANCHORS

-Place blocks at all four corners of the unit to keep the leveling anchors from coming into contact with the work table and also to maintain a level working surface. Install leveling the anchors for the mullions using fasteners as shown in **Detail 4-7** on **Page 59**. Refer to shop drawings for leveling bracket locations.

STEP 2: CS4 PARTS INSTALLATION

STEP 2a (Continued)

INSTALL MULLION SLEEVES AND LEVELING ANCHORS

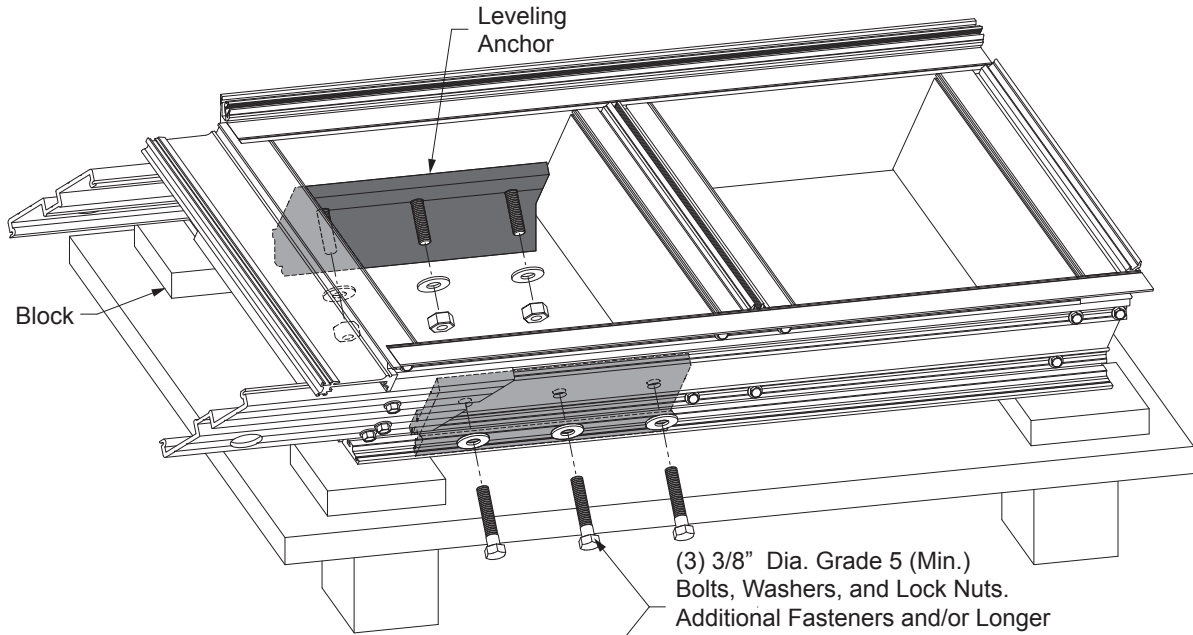

Detail 4-7

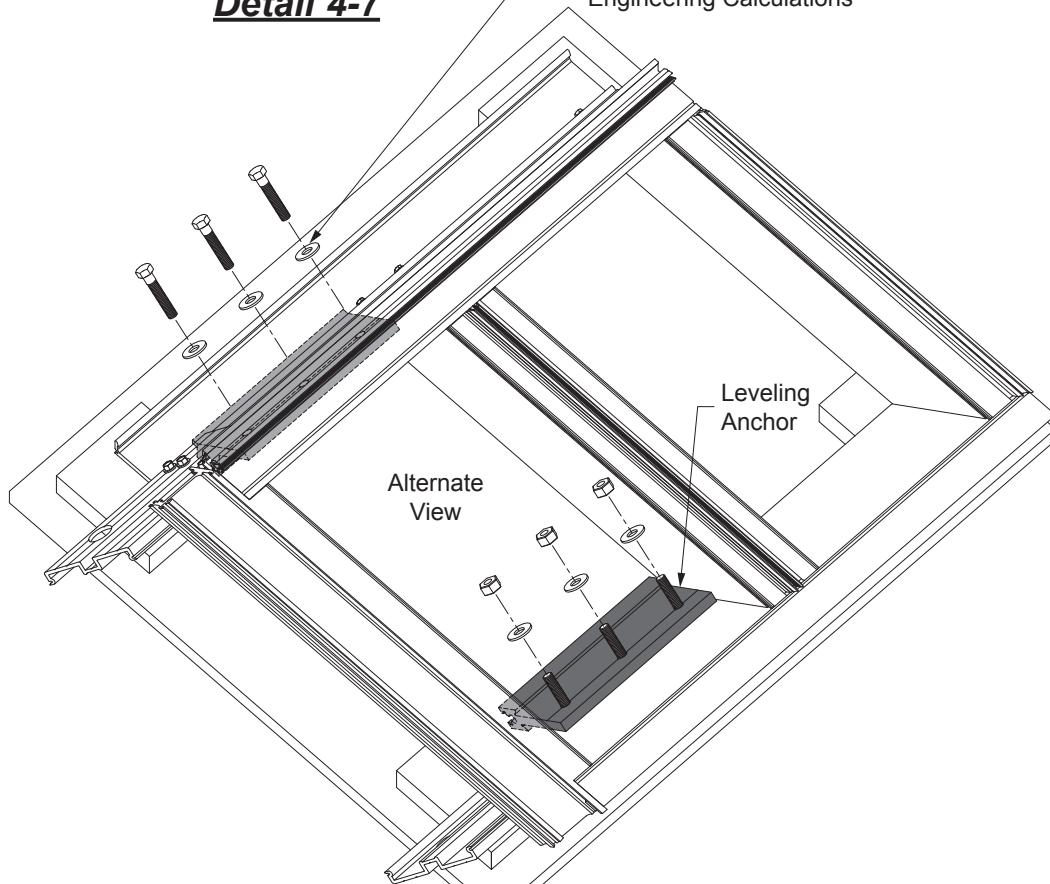

STEP 2: CS4 PARTS INSTALLATION

**STEP 2b
INSTALL MULLION INTERLOCKING CLIPS**

Mullion interlock clips are required. Refer to approved shop drawings / engineering calculations for location and quantity.

-Install mullion interlock clips into the outside corner female mullion and secure the clips in place with tape and sealant.

See **Detail 4-8** and **Detail 4-9**.

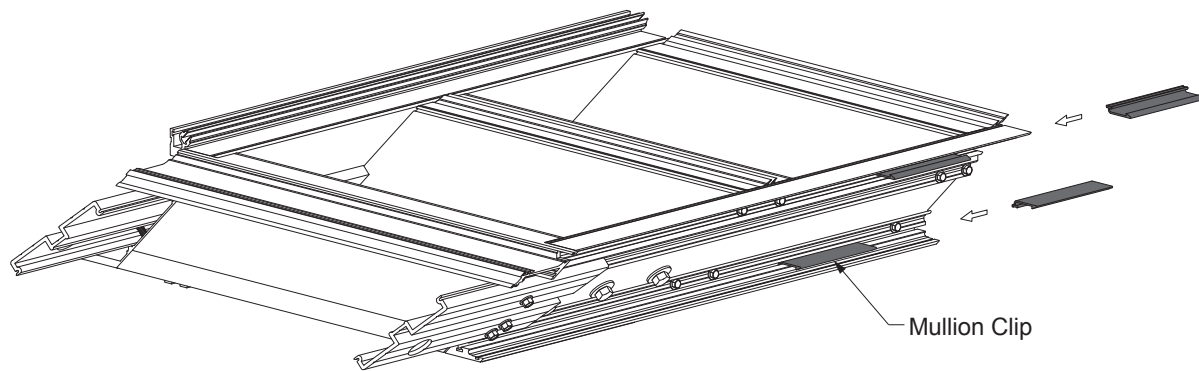

Detail 4-8

NOTE: If clip location coincides with an anchor lug or horizontal location, secure clips in place with sealant and tape just above or below to allow for tapping bar or screw installation.

****REVIEW WITH PROJECT ENGINEER TO MAKE SURE IF ADDITIONAL INTERLOCKING CLIPS ARE REQUIRED.

If steel is being installed in mullion, mullion interlock clips will have to be installed with steel after bay assembly to allow access to fasten horizontal mullions.

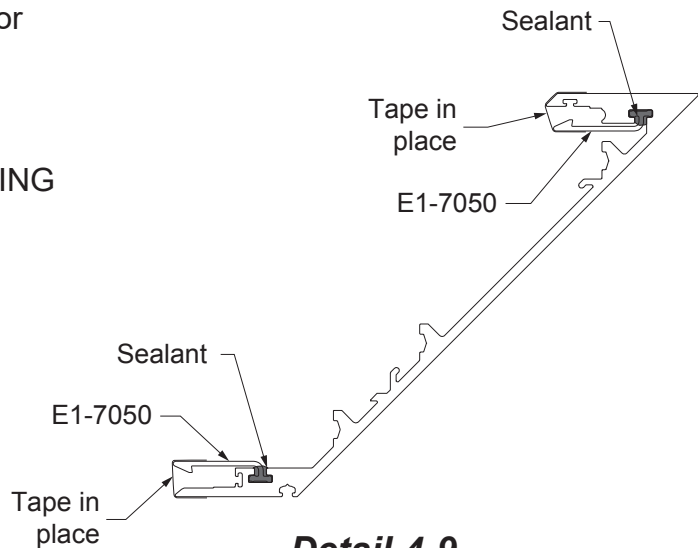

Detail 4-9

STEP 2: CS4 PARTS INSTALLATION

STEP 2c

INSTALL STEEL REINFORCING (If Required)

-Install steel or aluminum reinforcing as required to the mullions per approved shop drawings. Shim and fasten as required. Coordinate installation of steel with anchor lug backup.

See **Detail 4-10**.

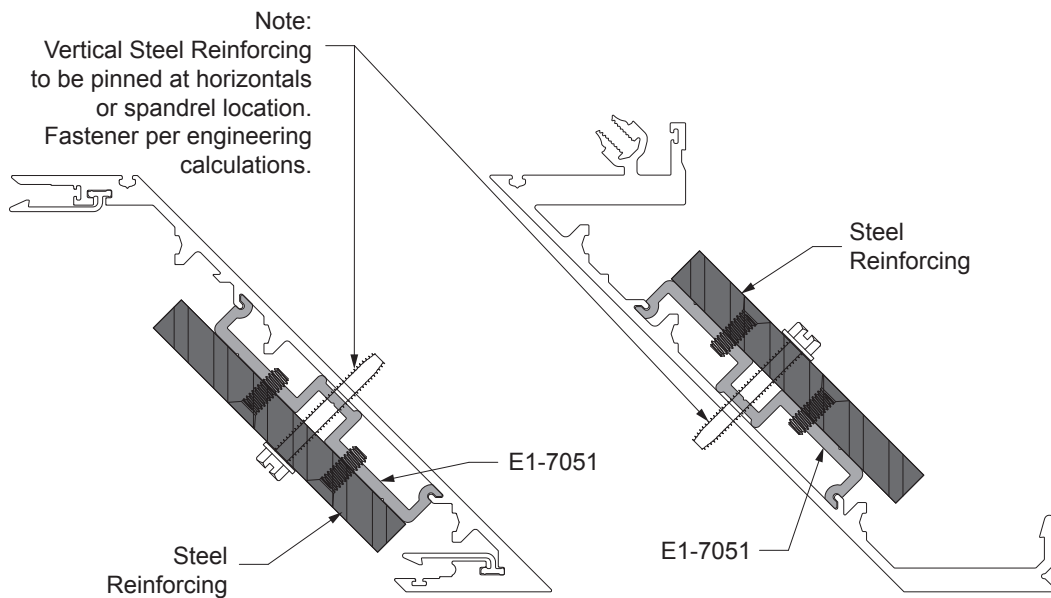

Detail 4-10

STEP 3: CS4 GASKET INSTALLATION**STEP 3a****INSTALL WEATHER SEAL GASKETS**

- Slide in weather seal gasket at the outer leg gasket raceway of the inside corner male mullion and into the inner leg gasket raceway of the outside corner female mullion as shown in **Detail 4-11**.
- Slide in the air water seal gasket at the outer leg gasket raceway of the outside corner female mullion.
- Crimp raceway at both ends of mullion by deforming the retaining leg of the gasket raceway in order to keep the gasket from sliding out during unit installation. Gaskets to run full length of mullion.

Note: Weather seal gasket is handed. Install gasket in the orientation as shown below.

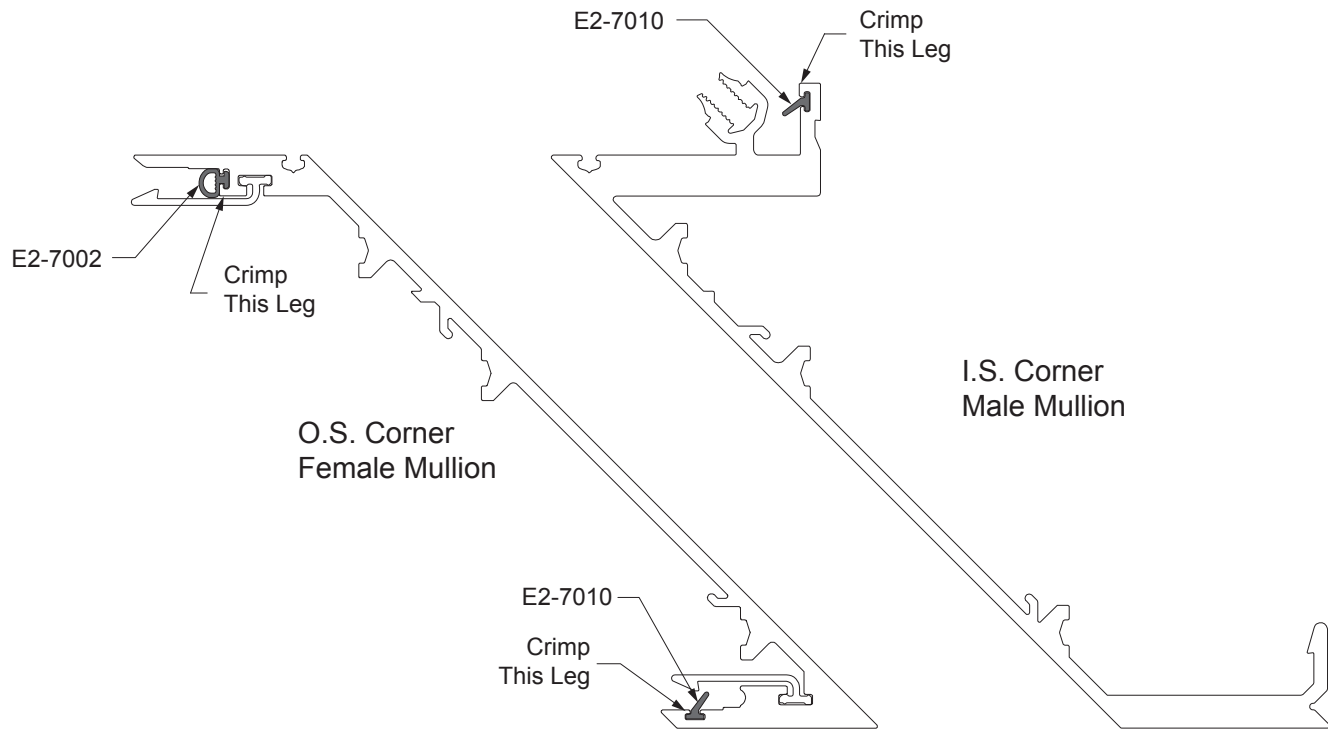

Detail 4-11

STEP 3: CS4 GASKET INSTALLATION

STEP 3b

INSTALL INTERIOR GLAZING GASKETS

- Secure the assembled unit to a flat surface with the exterior facing up. Table must be flat and level, and must support frame at all locations. A unit glazed with any mullion deflection will cause installation problems. Additional bracing under the glass may be required with large glass lites to prevent glass deflection.
- Clean and prepare glass and aluminum surfaces in strict conformity with sealant manufacturer's specifications and requirements.
- Install E2-7001 interior gasket on all horizontals. Install E2-7014 spacer on the corner mullions (except for impact systems where E2-0724 is used on the inside corner male mullion). Horizontal gaskets are to be cut to D.L.O. Corner spacer is to be cut to D.L.O. + 1-1/2". Vertical gaskets are to be installed first, followed by the horizontal gaskets.

See **Detail 4-12**.

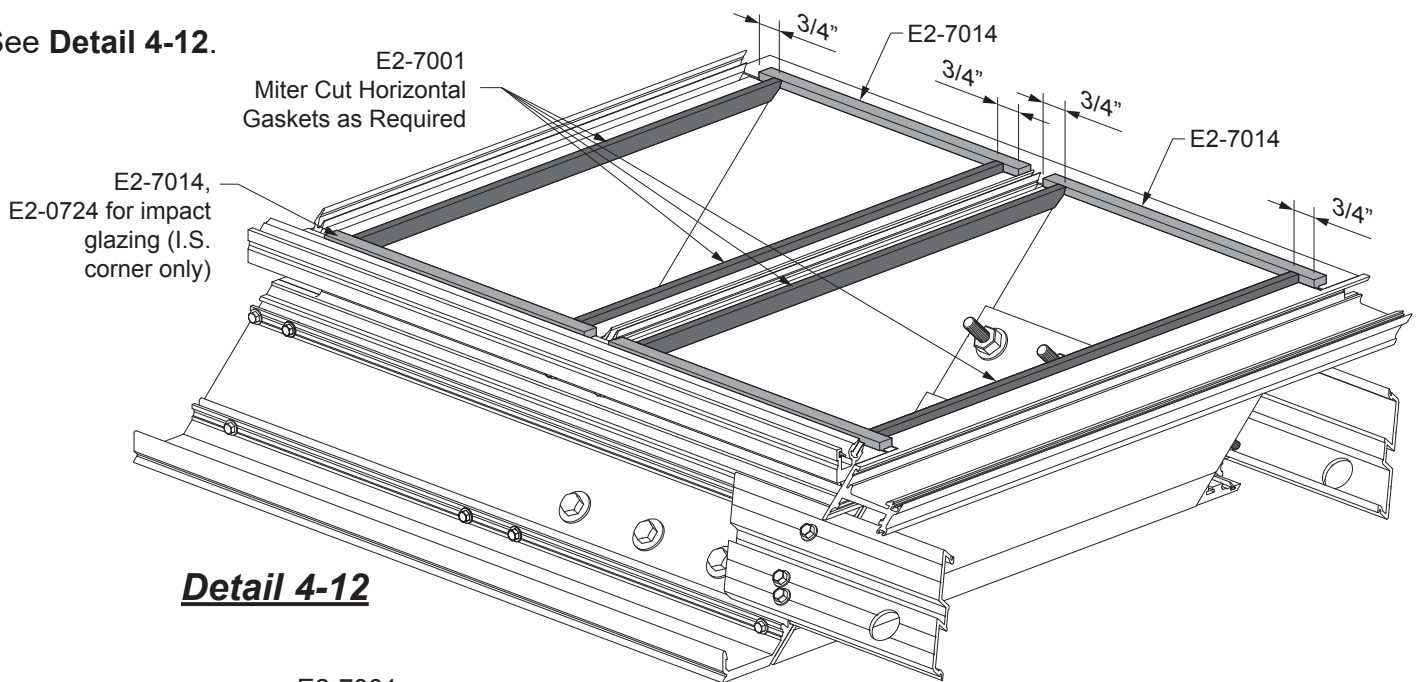

Detail 4-12

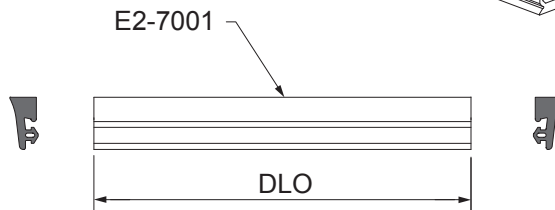

Note:

Before installing the glass, double-check squareness of frame by measuring diagonals. The maximum difference between diagonals is 1/16". Sight down mullions to make sure unit is not bowed. A unit glazed in a "out of square" or "bowed" position will cause installation problems.

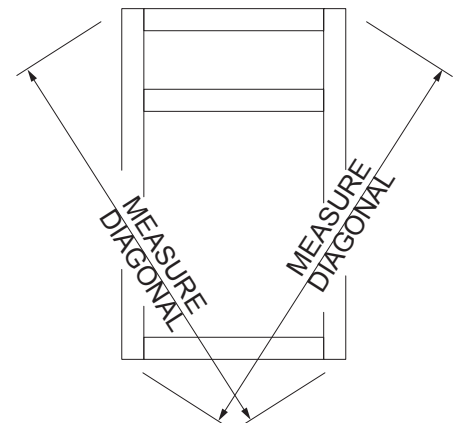

STEP 4: CS4 GLASS INSTALLATION**STEP 4a****INSTALL SETTING BLOCK CHAIRS AND SETTING BLOCKS**

-Apply setting block chairs and temporarily apply setting blocks oriented outward on setting block chairs placed at 1/4 points of horizontals as shown in **Detail 4-13**.

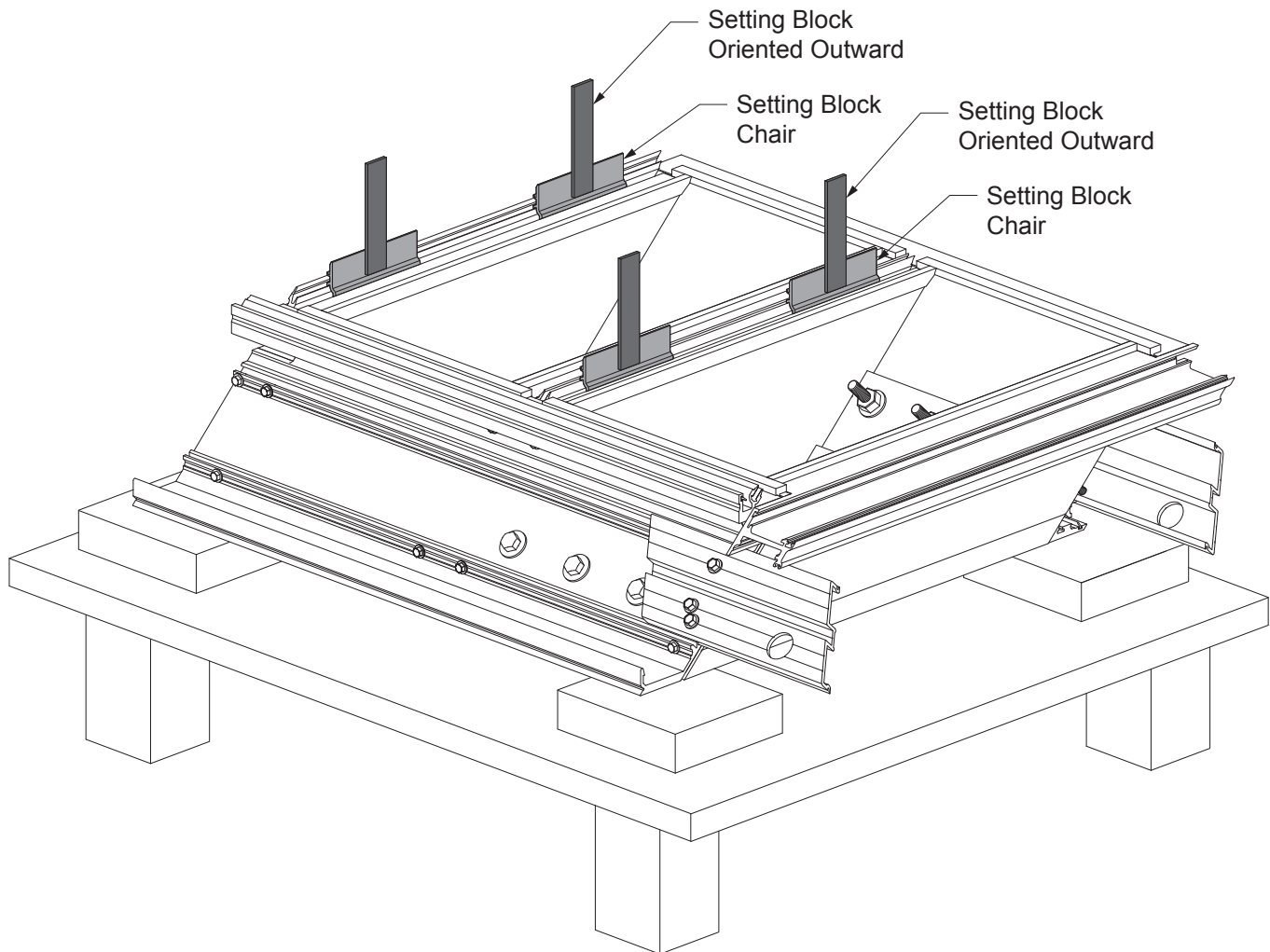
**Detail 4-13**

STEP 4: CS4 GLASS INSTALLATION

**STEP 4b
INSTALL GLASS**

- Position the glass laterally in the D.L.O. as shown in Detail 4-14.
- Install glass by placing bottom edge against both setting blocks and lower into place.
- When glass is properly positioned, remove setting blocks. Take caution to not move glass during setting block removal. Large units may require additional support at the corner mullion to prevent distortion under the weight of the glass.
- Reference shop details and glazing details for non typical conditions.

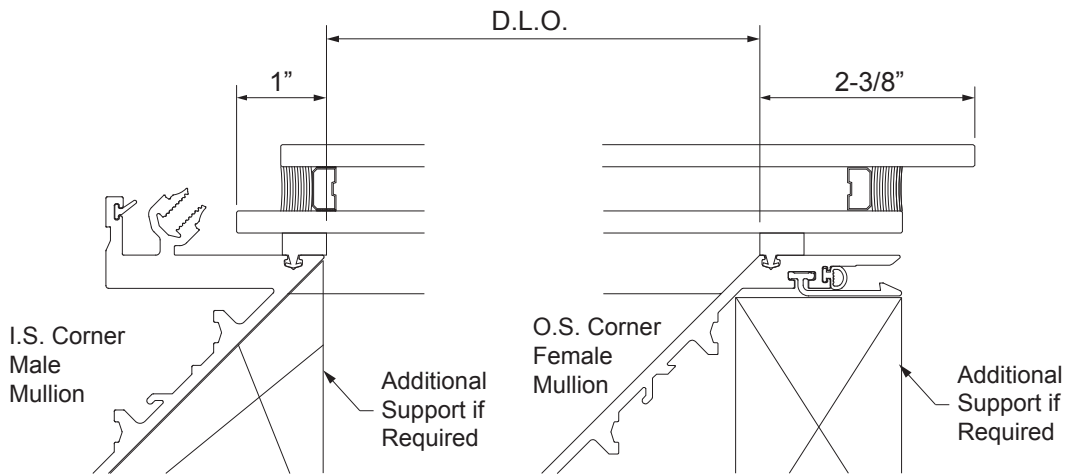

Detail 4-14

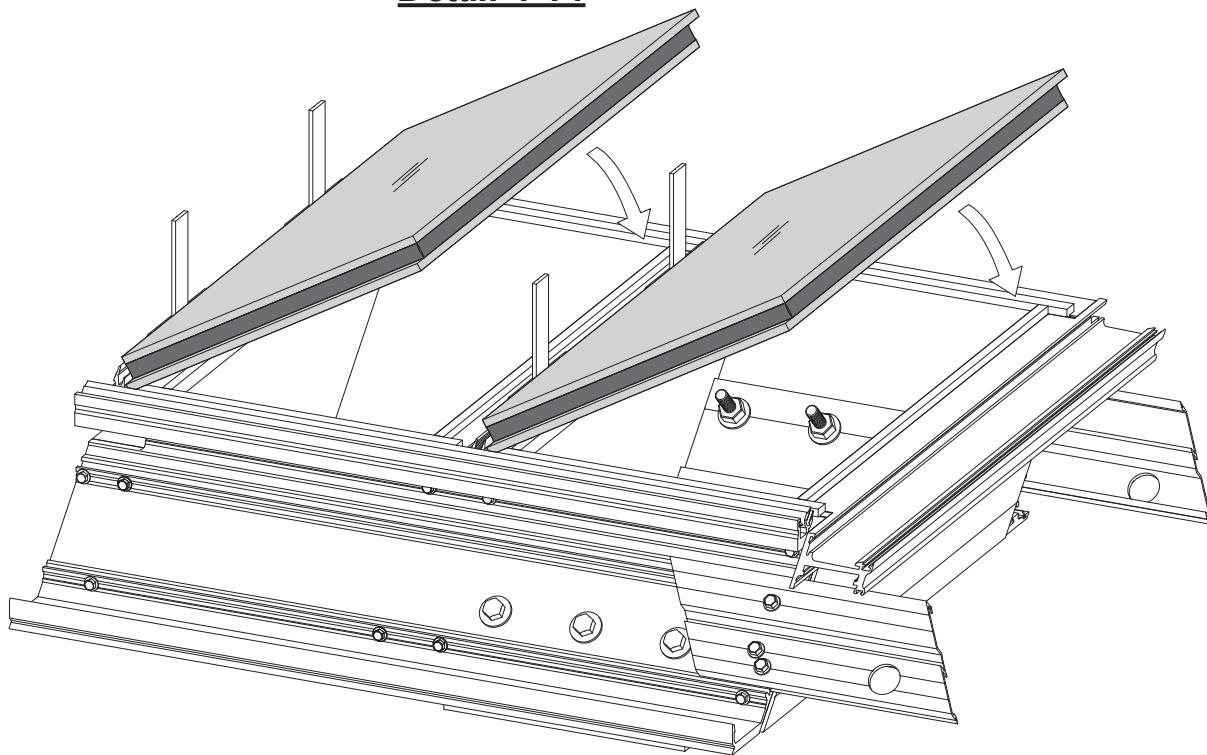

STEP 4: CS4 GLASS INSTALLATION**STEP 4b (Continued)
INSTALL GLASS**

- Ensure that the glass and metal surfaces are clean and prepared per sealant manufacturer's specifications and recommendations.
- Apply structural silicone sealant completely filling the space between the glass and the mullion. (Slide setting block chairs out of the way temporarily while sealing units.)
- Tool sealant. Clean out any excess sealant in horizontal groove and engagement areas.

See **Detail 4-15**.

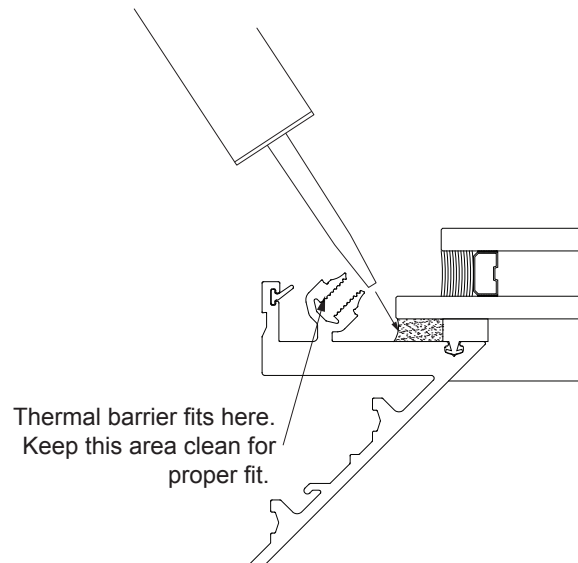

Detail 4-15

STEP 4: CS4 GLASS INSTALLATION

STEP 4b (Continued)
INSTALL GLASS

-Apply silicone in I.G.U. cap trace. Rotate and hook in E3-7002 I.G.U. cap. Apply flush with the perimeter edge of the jamb. Tool sealant flush with top of I.G.U. cap.

See **Detail 4-16**.

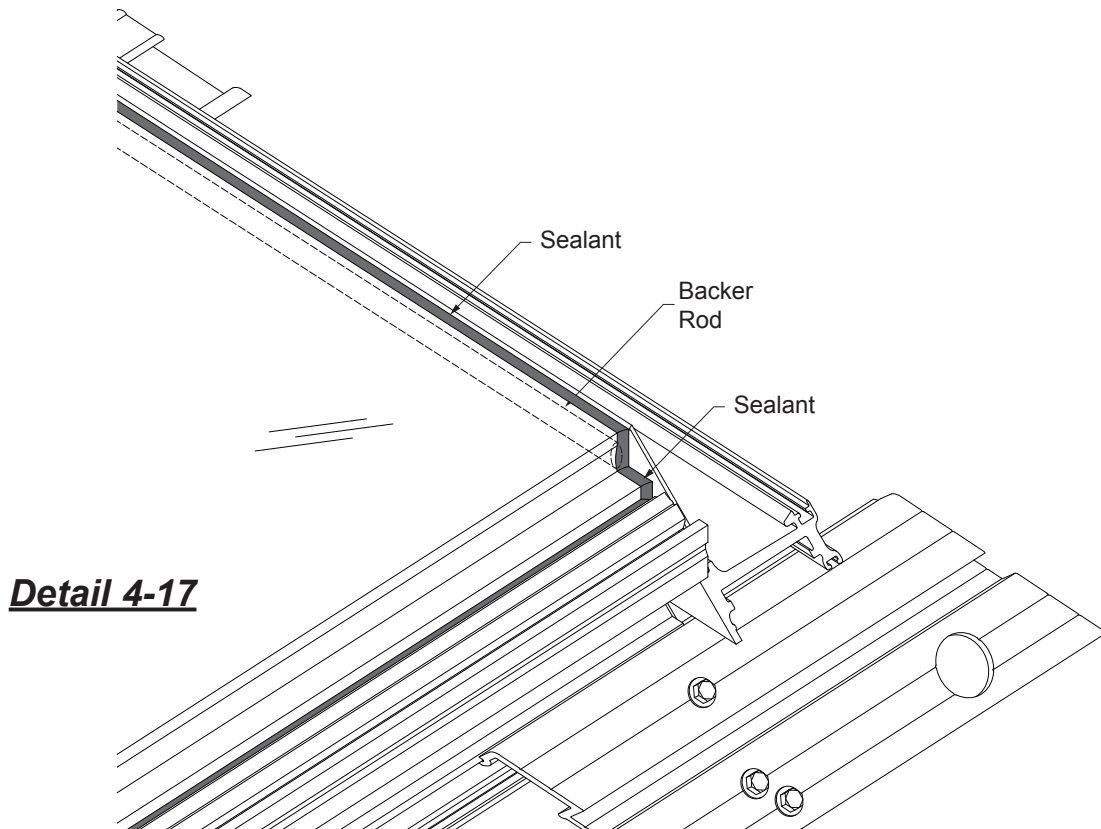
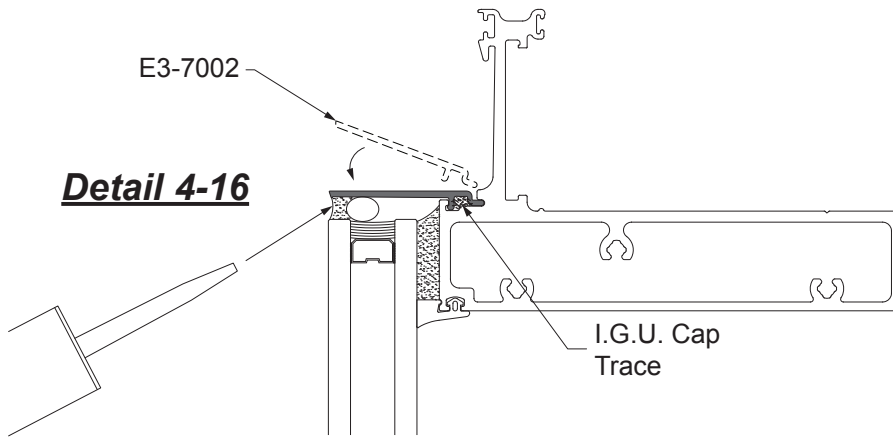

STEP 4: CS4 GLASS INSTALLATION

**STEP 4c
INSTALL THERMAL SHIELD**

- Before installing the thermal shield, apply a few dabs of sealant to keep it in place.
 - Snap thermal shield into the front of the stacking sill, centered on the D.L.O. See **Detail 4-18**.
 - Install backer rods to the joint and completely fill intermediate horizontal and stacking sill joints with sealant as shown on **Detail 4-19**.
- Tool excess sealant to ensure a complete seal. Be sure to keep sealant out of horizontal groove and engagement areas.

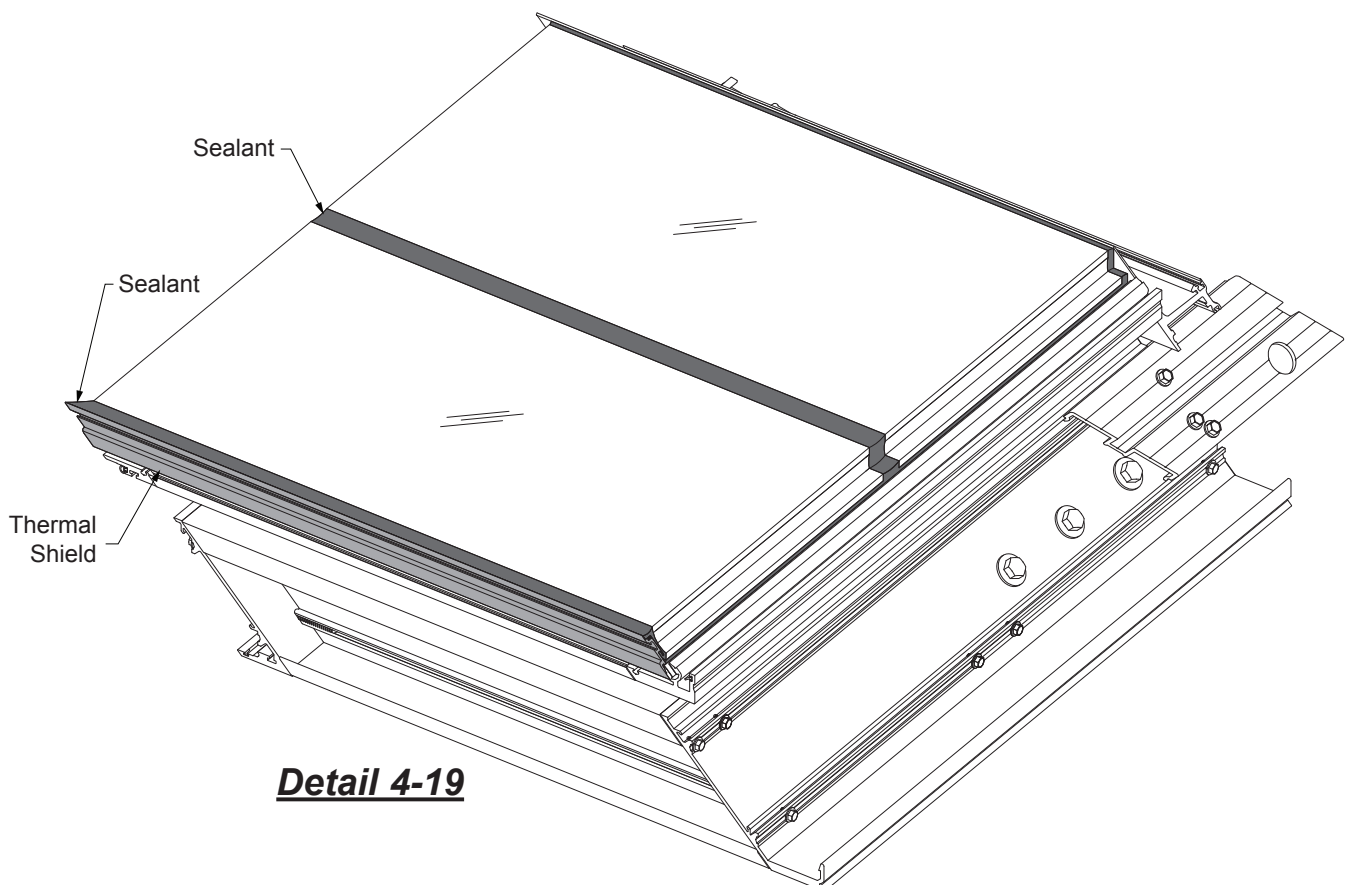
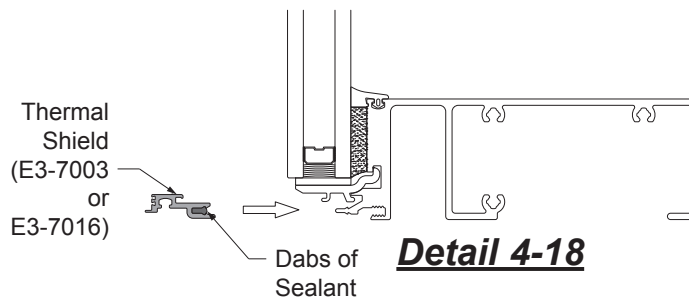

STEP 5: CS4 THERMAL BARRIER & WEATHERSEAL INSTALLATION

STEP 5a

INSTALL SSG THERMAL BARRIER & GASKET

-Snap in SSG Thermal Barrier into the corner mullion raceway.

-Push in the SSG Wiper Gasket E2-7015 into the SSG thermal barrier. Align according to unit module.

See **Detail 4-20**.

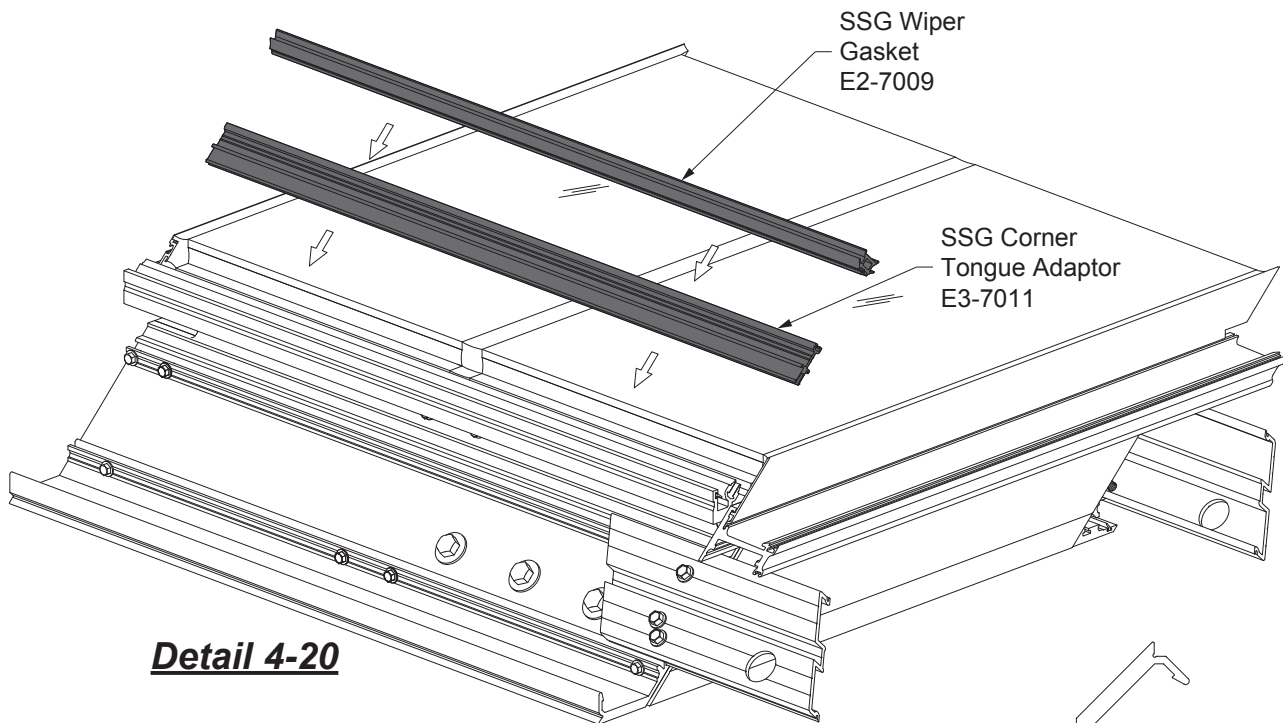

-Apply a dab of sealant at both ends of the gasket and thermal barrier to hold them in place.

See **Detail 4-21**.

Detail 4-21

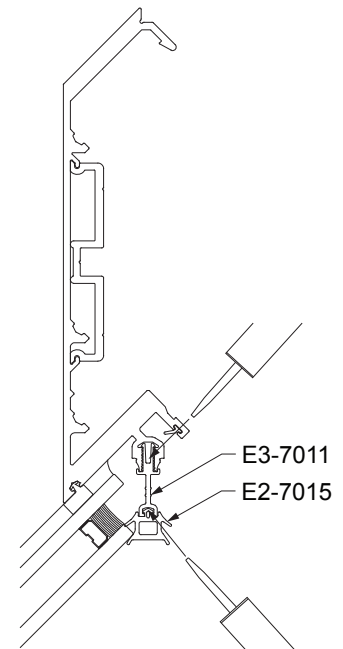

STEP 5b

INSTALL STACKING SILL WEATHER SEAL

-Refer to **CS1 Thermal Barrier & Cover Installation, Step 5c on Page 20**.

STEP 5: CS4 THERMAL BARRIER & COVER INSTALLATION

STEP 5c

INSTALL STACKING TRAY ACCESSORIES

- Slide in E2-3906 stack isolator into stacking tray as shown in **Detail 4-22**.
- Slide in E2-7004 air/water seal gasket positioned starting at 2" from the perimeter edge of the female mullion and extending 6" beyond the corner male mullion as shown in **Detail 4-23**. Affix the gasket with a small amount of silicone.

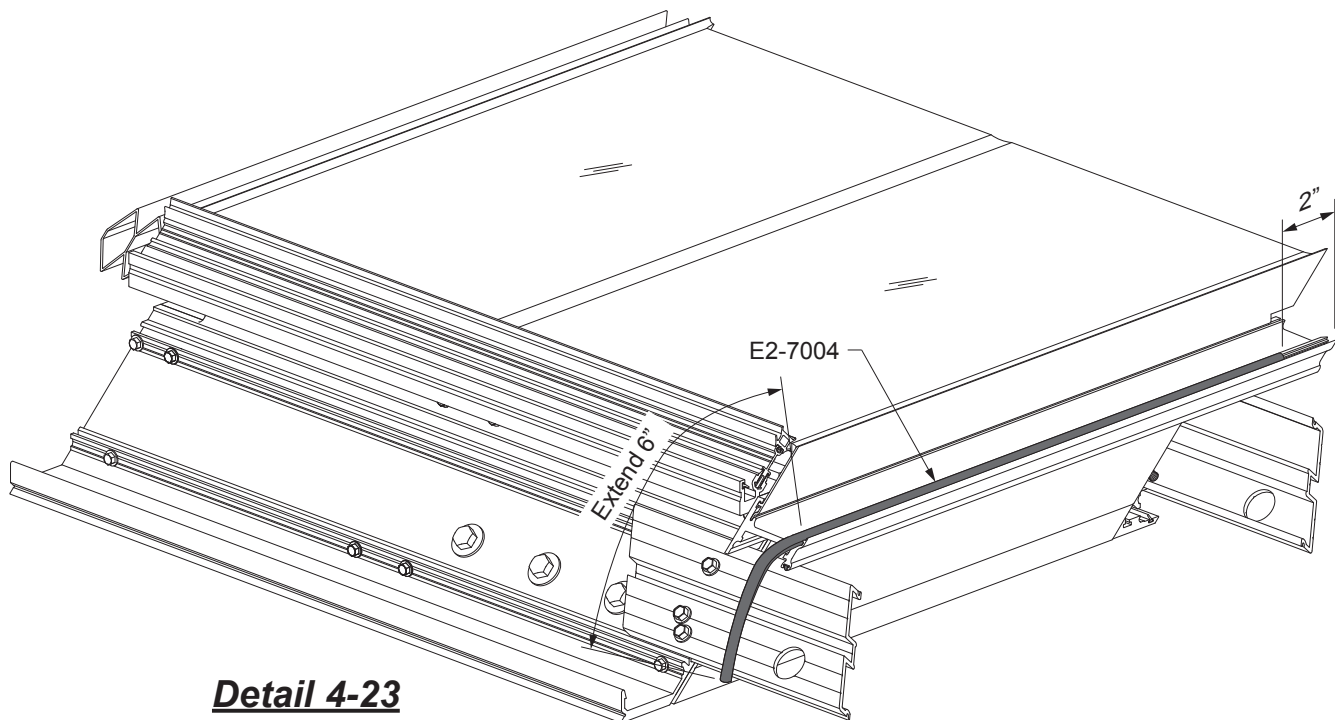
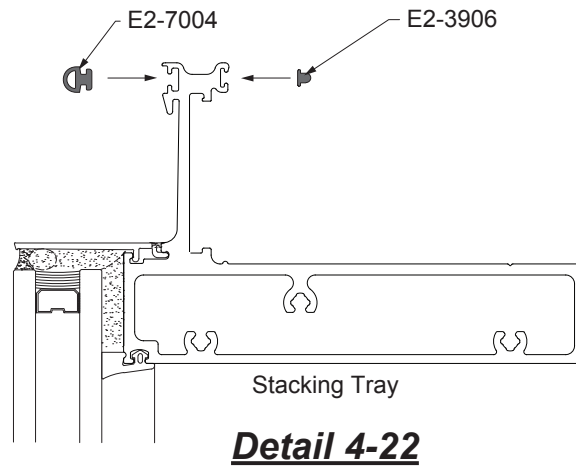

CS5 TABLE OF CONTENTS

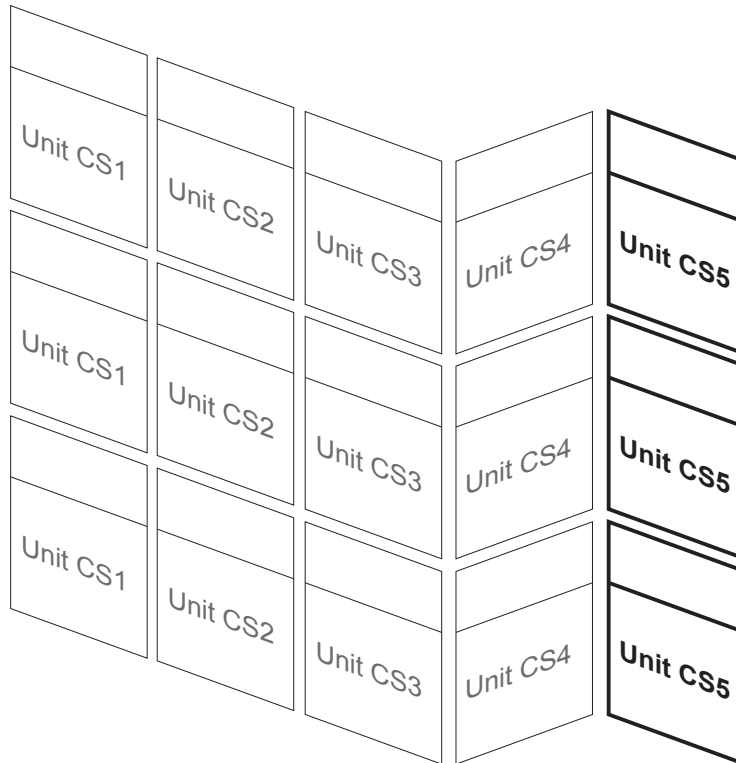

The following is intended for use as a guide for assembly of **Unit CS5** of the **YUW 750 XT 4-Sided SSG Curtain Wall System**. It is organized into five steps which will take you from assembly of parts to completed units.

Step 1: CS5 Unit Assembly	Pages 72 to 76
Step 2: CS5 Parts Installation	Pages 77 to 80
Step 3: CS5 Gasket Installation	Pages 81 & 82
Step 4: CS5 Glass Installation	Pages 83 to 87
Step 5: CS5 Thermal Barrier & Weatherseal Installation.....	Pages 88 to 90

Care should be taken to ensure you have inventory of all items required to complete this assembly. We recommend you refer to the parts list (pages iv - viii) as a reference and compare it to your specific project to ensure you have all the correct parts and tools required to complete the assembly.

STEP 1: CS5 UNIT ASSEMBLY

MAJOR COMPONENTS

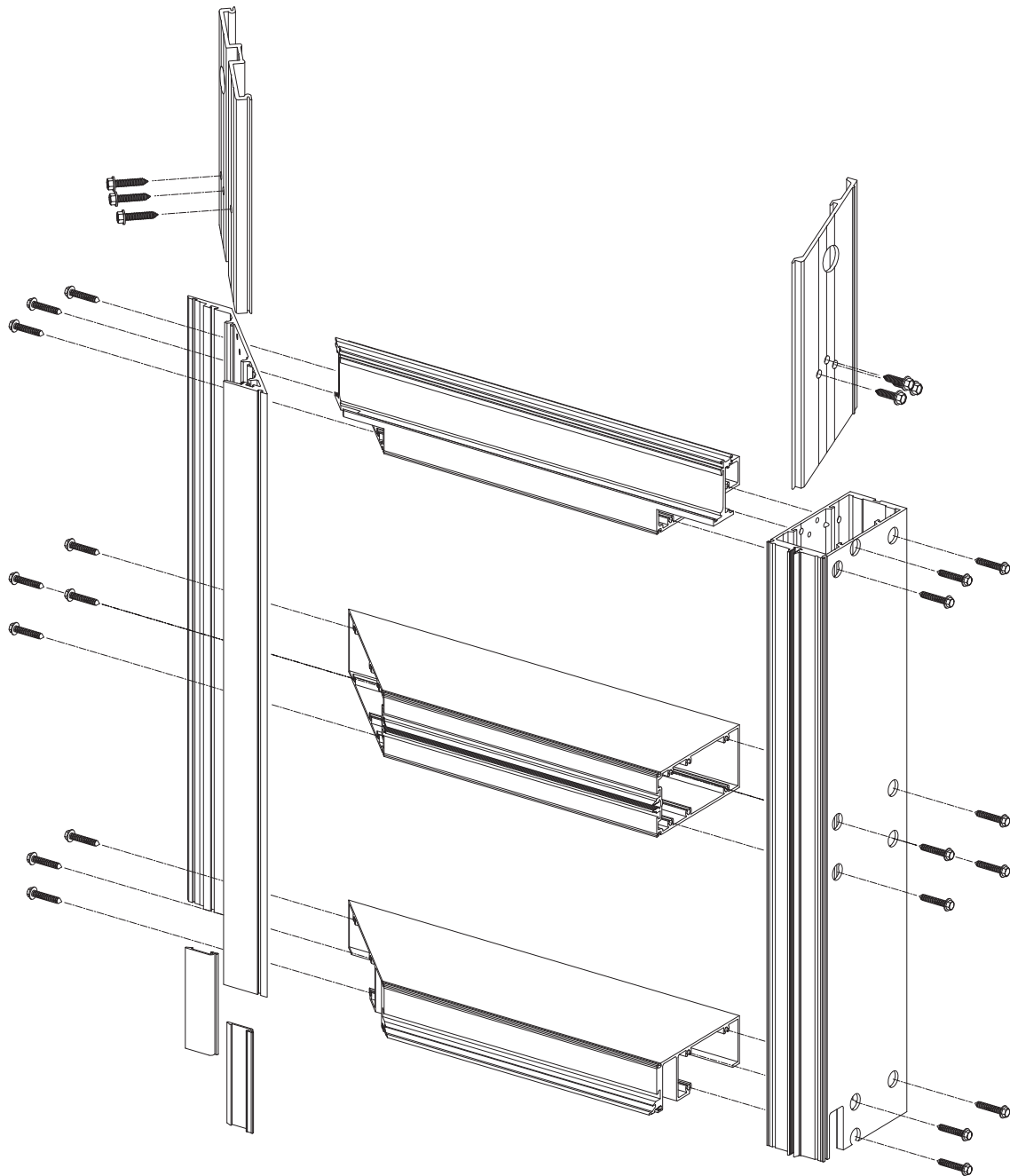

STEP 1: CS5 UNIT ASSEMBLY

STEP 1a

APPLY SEALANT TO FRAMING MEMBERS

-Clean, prime and apply sealant to both ends of horizontals and tops of verticals per typical unit detail and approved shop drawings.

See **Detail 5-1**.

Stacking Tray: seal at the front wall and bottom wall back to 1st screw spline.

Intermediate Horizontals: seal at the front of tube back to 1st screw spline.

Stacking Sill: seal at the front leg, 1" back along top of sill.

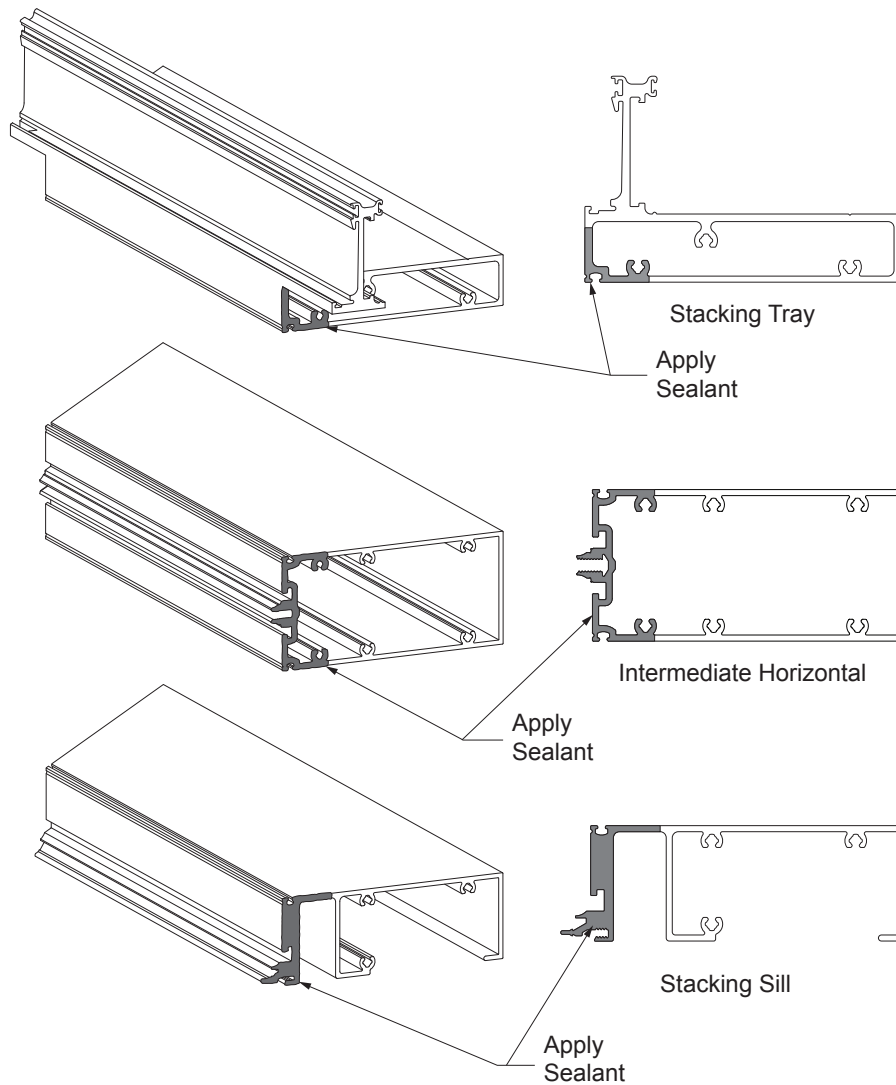

Detail 5-1

STEP 1: CS5 UNIT ASSEMBLY

**STEP 1a (Continued)
APPLY SEALANT TO FRAMING MEMBERS**

Vertical Mullions: seal top of inside corner female mullion and jamb mullion as shown in **Detail 5-2**.

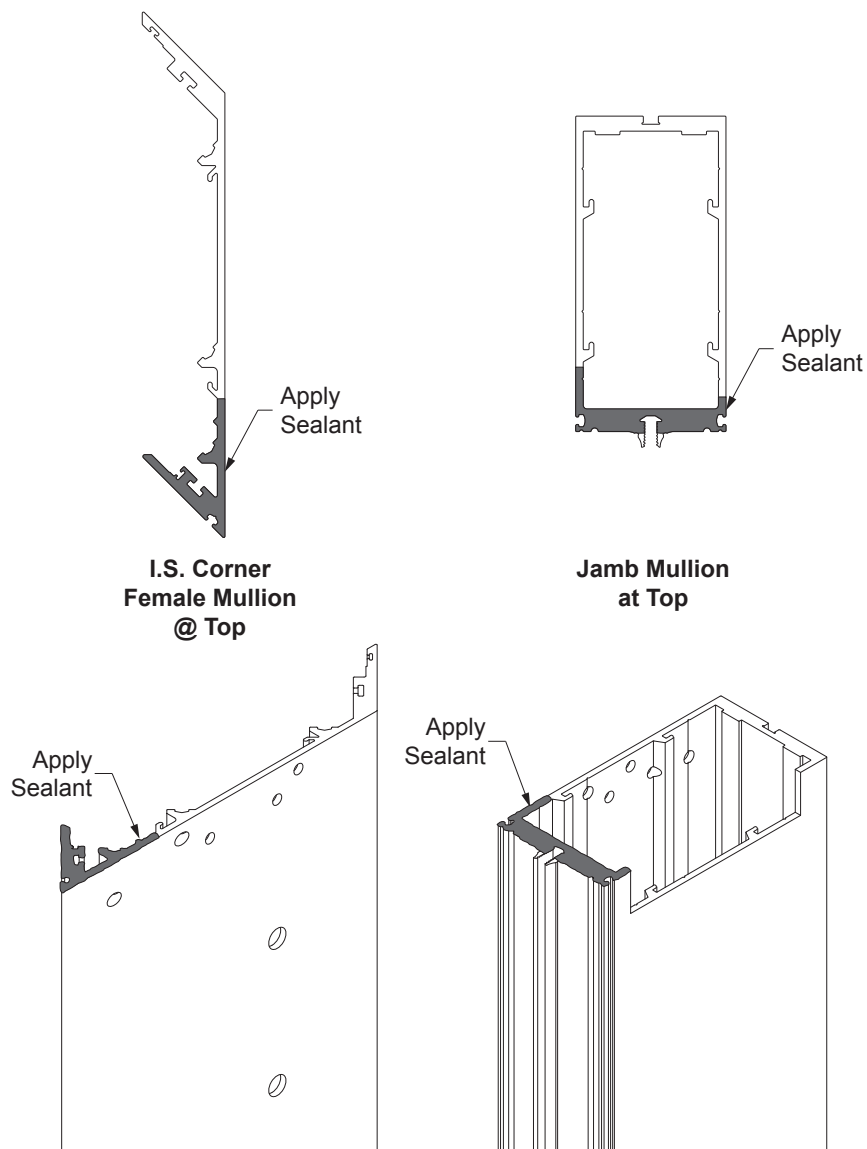

Detail 5-2

STEP 1: CS5 UNIT ASSEMBLY

STEP 1b

ATTACH VERTICAL MULLIONS TO HORIZONTALS

-Position horizontal members aligning splines with screw holes in the jamb mullion and assemble with HC-1220-SS fasteners as shown in **Detail 5-3**. Wipe off excess sealant.

Note: Take care to keep sealant from getting into gasket raceways, setting block chair pockets and around stems.

-Tool all excess sealant flush.

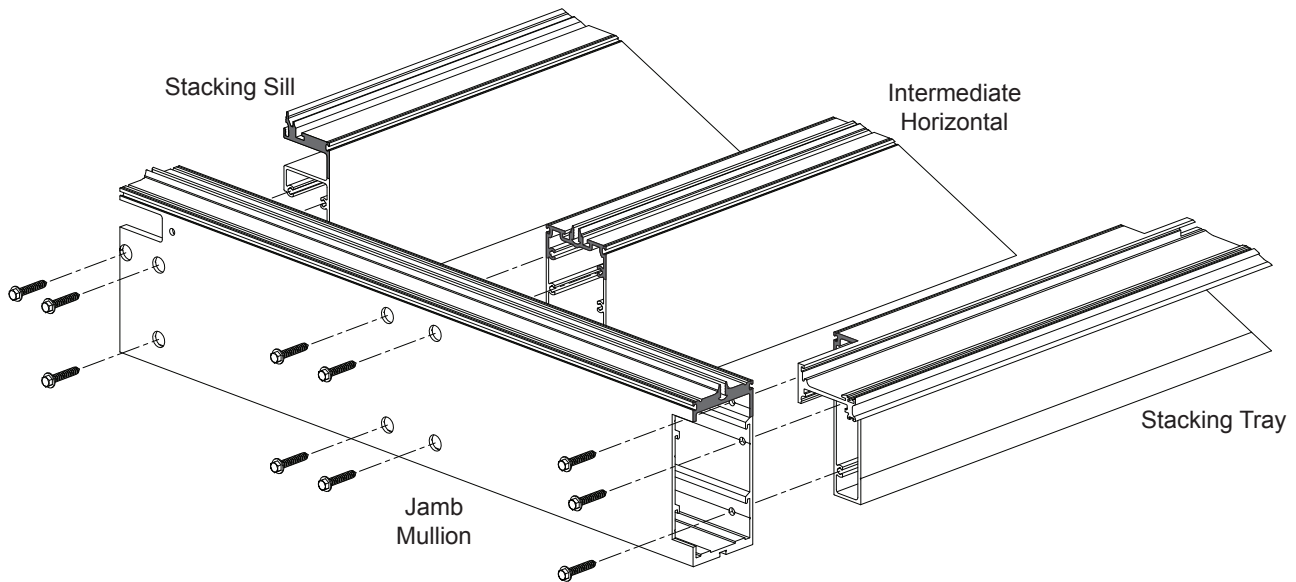

Detail 5-3

STEP 1: CS5 UNIT ASSEMBLY**STEP 1b (Continued)****ATTACH VERTICAL MULLIONS TO HORIZONTALS**

-Position horizontal members aligning splines with screw holes in the inside corner female mullion and assemble with HC-1228-SS fasteners as shown in **Detail 5-4**. Wipe off excess sealant.

Note: Take care to keep sealant from getting into gasket raceways, setting block chair pockets and around stems.

-Tool all excess sealant flush.

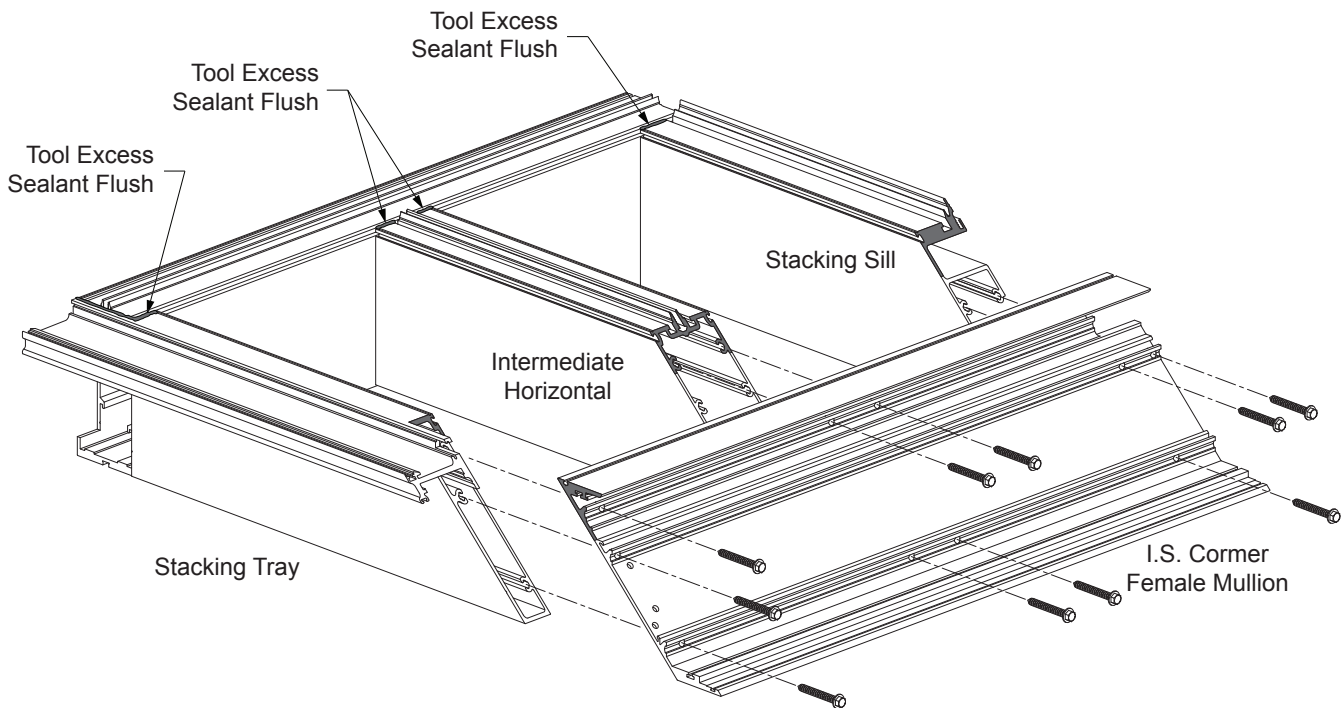
**Detail 5-4**

STEP 2: CS5 PARTS INSTALLATION

STEP 2a

JAMB PREPARATION

-Refer to **CC1 Parts Installation, Step 2a** on **Page 7**.

STEP 2b

INSTALL MULLION SLEEVES AND LEVELING ANCHORS

-Using HD-2520-W3 fasteners, install the mullion sleeves as shown in **Detail 5-5**, unless noted otherwise on the approved shop drawings.

Note: HD-2520-W3 fasteners (3 shown per sleeve) are sufficient for units weighing up to 2,350 lbs. Units weighing beyond that will require modifications to the anchor and/or fasteners.

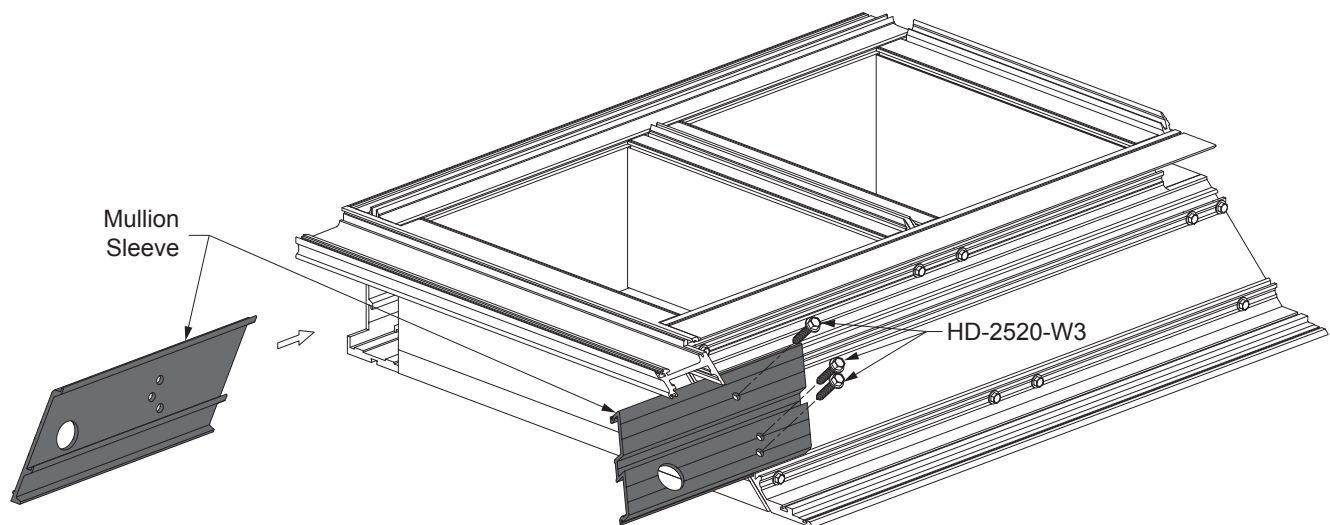

Detail 5-5

STEP 2: CS5 PARTS INSTALLATION**STEP 2b (Continued)****INSTALL MULLION SLEEVES AND LEVELING ANCHORS**

-Place blocks at all four corners of the unit to keep the leveling anchors from coming into contact with the work table and also to maintain a level working surface. Install leveling the anchors for the mullions using fasteners as shown in **Detail 5-6**. Refer to shop drawings for leveling bracket locations.

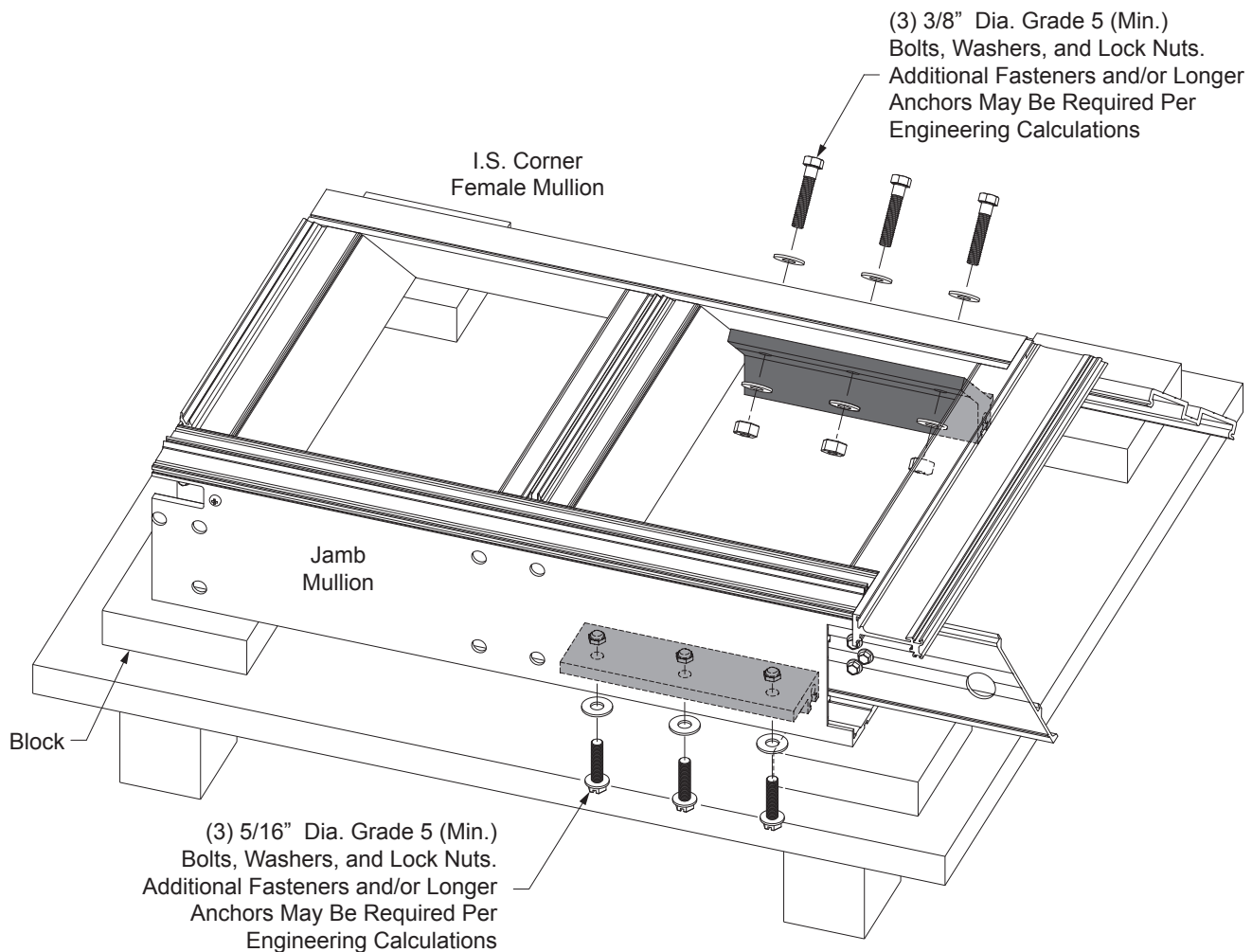
**Detail 5-6**

STEP 2: CS5 PARTS INSTALLATION

STEP 2c

INSTALL MULLION INTERLOCKING CLIPS

Mullion interlock clips are required. Refer to approved shop drawings / engineering calculations for location and quantity.

-Install mullion interlock clips into the inside corner female mullion and secure the clips in place with tape and sealant.

See **Detail 5-7** and **Detail 5-8**.

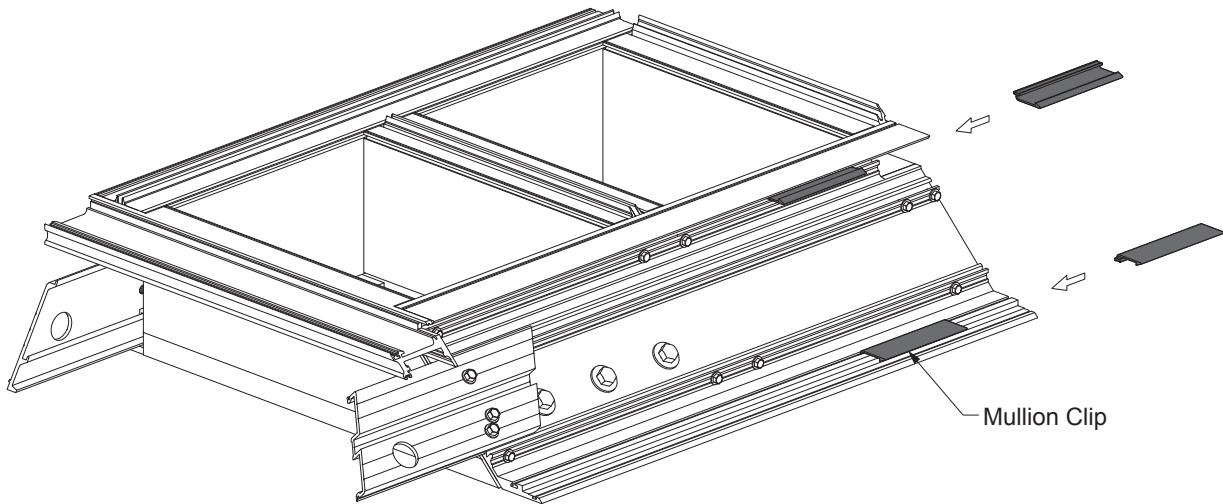

Detail 5-7

NOTE: If clip location coincides with an anchor lug or horizontal location, secure clips in place with sealant and tape just above or below to allow for tapping bar or screw installation.

****REVIEW WITH PROJECT ENGINEER TO MAKE SURE IF ADDITIONAL INTERLOCKING CLIPS ARE REQUIRED.

If steel is being installed in mullion, mullion interlock clips will have to be installed with steel after bay assembly to allow access to fasten horizontal mullions.

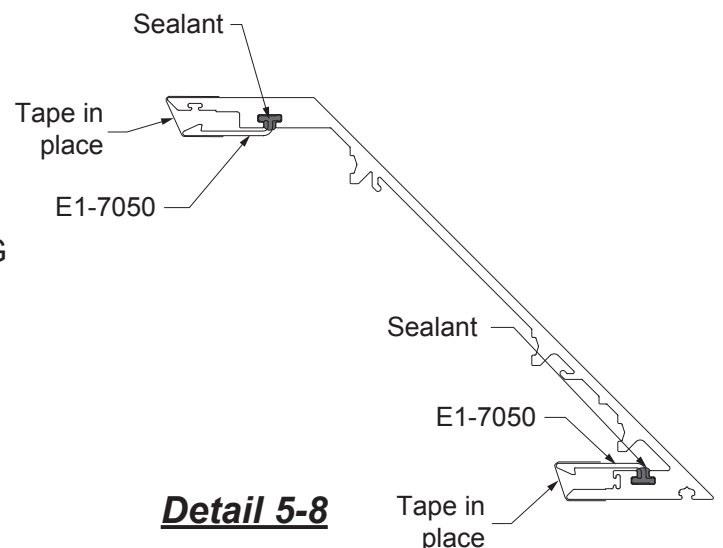

Detail 5-8

STEP 2: CS5 PARTS INSTALLATION**STEP 2c****INSTALL STEEL REINFORCING (If Required)**

-Install steel or aluminum reinforcing as required to the mullions per approved shop drawings. Shim and fasten as required. Coordinate installation of steel with anchor lug backup.

See **Detail 5-9**.

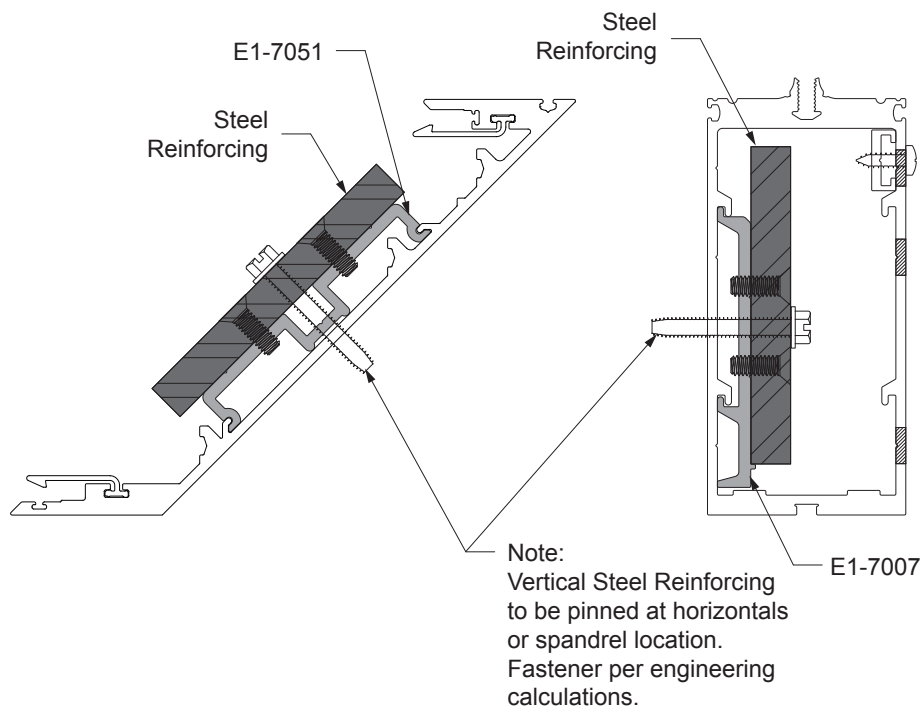

Detail 5-9

STEP 3: CS5 GASKET INSTALLATION

STEP 3a

INSTALL WEATHER SEAL GASKETS

- Slide in the air water seal gasket at the outer leg gasket raceway of the inside corner female mullion as shown in **Detail 5-10**.
- Crimp raceway at both ends of mullion by deforming the retaining leg of the gasket raceway in order to keep the gasket from sliding out during unit installation. Gaskets to run full length of mullion.

Note: Weather seal gasket is handed. Install gasket in the orientation as shown below.

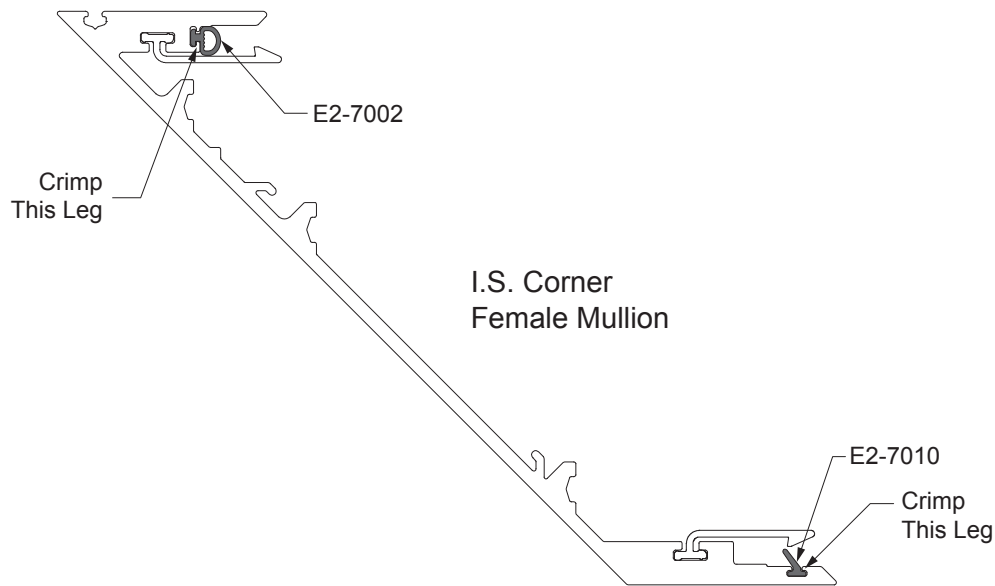

Detail 5-10

STEP 3b

SEAL HORIZONTAL INTERSECTIONS

- Refer to **CS1 Gasket Installation, Step 3b** on **Page 11**.

STEP 3: CS5 GASKET INSTALLATION

**STEP 3c
INSTALL INTERIOR GLAZING GASKETS**

- Secure the assembled unit to a flat surface with the exterior facing up. Table must be flat and level, and must support frame at all locations. A unit glazed with any mullion deflection will cause installation problems. Additional bracing under the glass may be required with large glass lites to prevent glass deflection.
- Clean and prepare glass and aluminum surfaces in strict conformity with sealant manufacturer's specifications and requirements.
- Install E2-7001 interior gasket on all horizontals and the jamb mullion. Install E2-7014 spacer on the inside corner female mullion (except for impact systems where E2-0724 is used on the inside corner male mullion). Horizontal gaskets are to be cut to D.L.O. Corner spacer is to be cut to D.L.O. + 1-1/2". Vertical gaskets are to be installed first, followed by the horizontal gaskets.

See **Detail 5-11**.

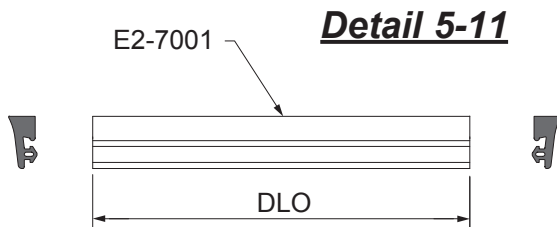
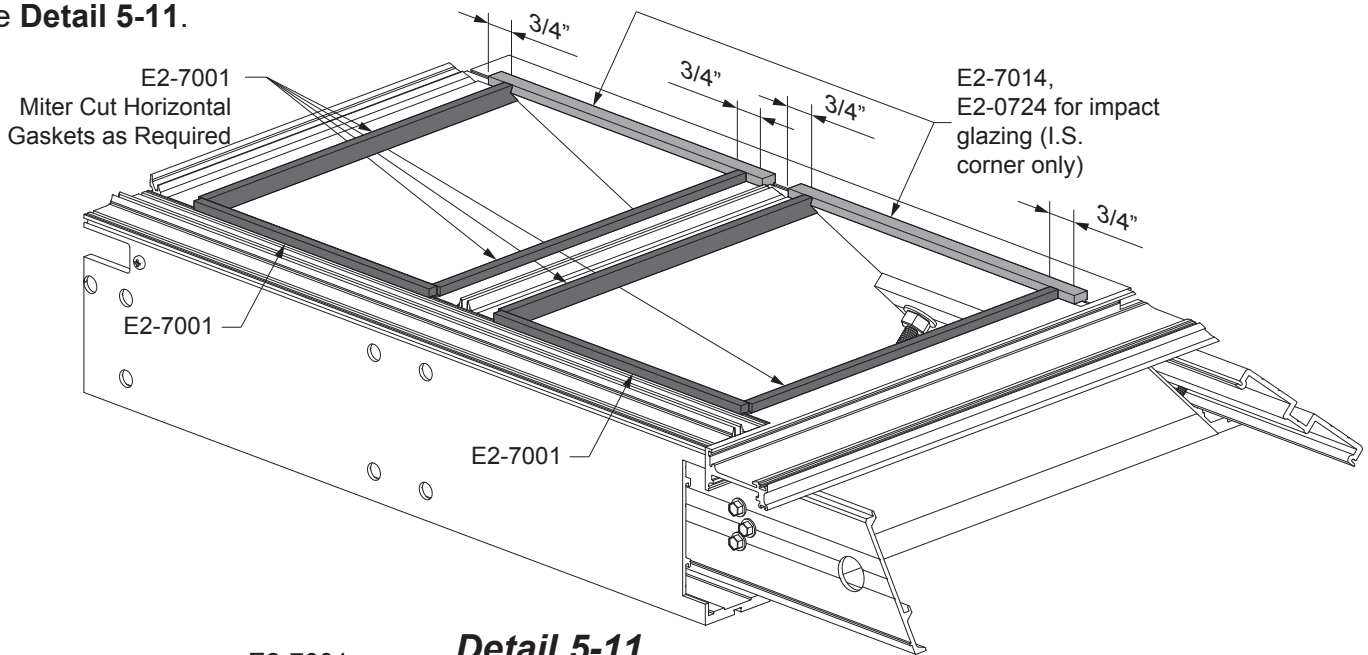

Note:
Before installing the glass, double-check squareness of frame by measuring diagonals. The maximum difference between diagonals is 1/16". Sight down mullions to make sure unit is not bowed. A unit glazed in a "out of square" or "bowed" position will cause installation problems.

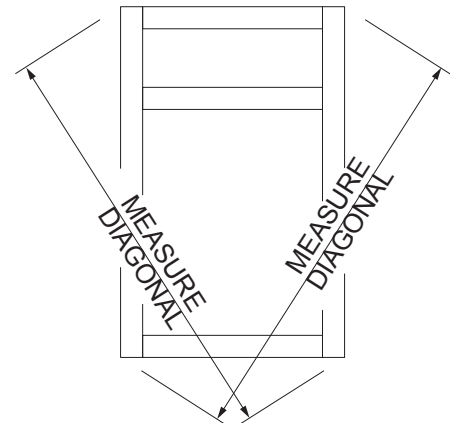

STEP 4: CS5 GLASS INSTALLATION

STEP 4a

INSTALL SETTING BLOCK CHAIRS AND SETTING BLOCKS

-Apply setting block chairs and temporarily apply setting blocks oriented outward on setting block chairs placed at 1/4 points of horizontals as shown in **Detail 5-12**.

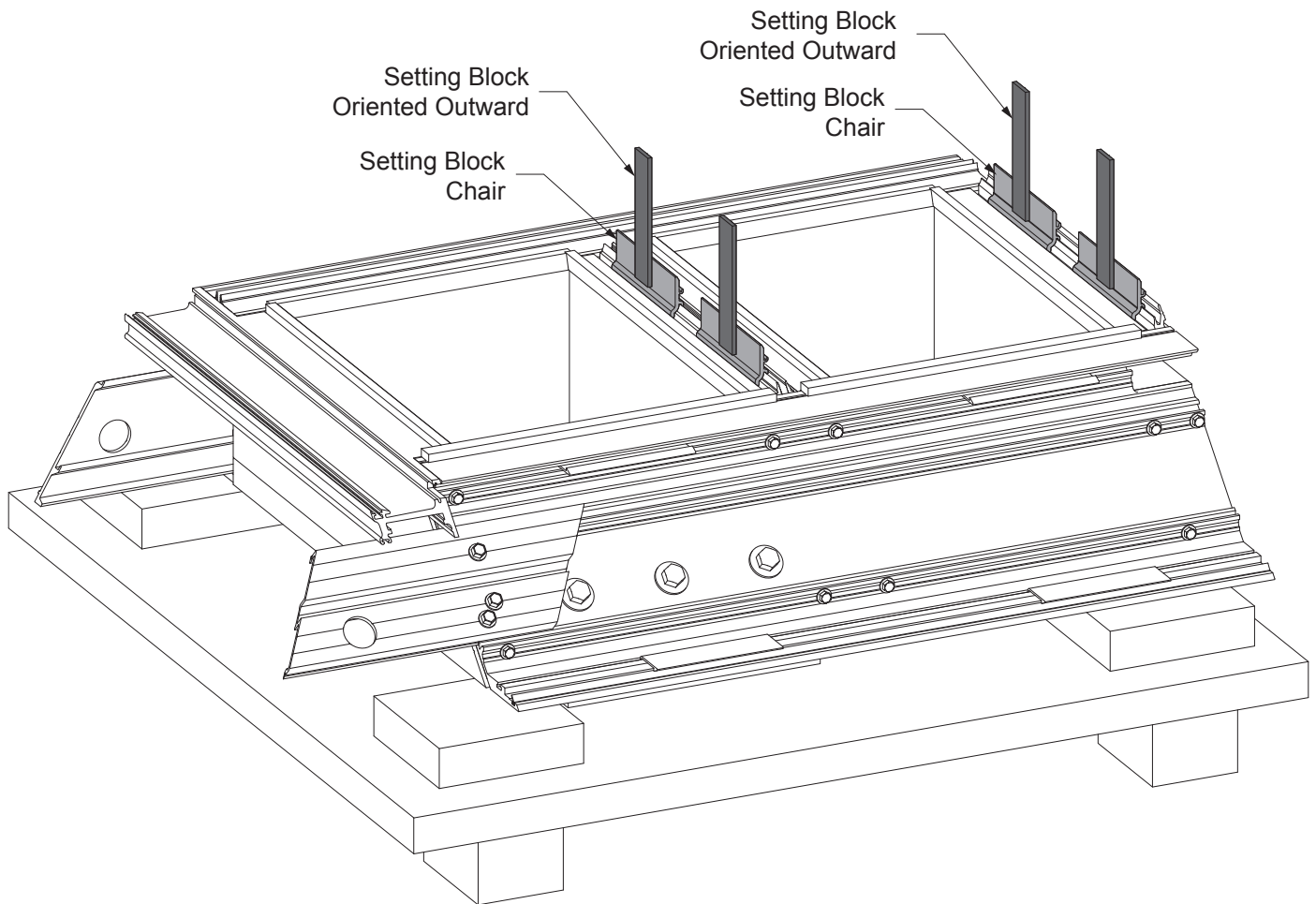

Detail 5-12

STEP 4: CS5 GLASS INSTALLATION

**STEP 4b
INSTALL GLASS**

- Position the glass laterally in the D.L.O. as shown in Detail 5-13.
- Install glass by placing bottom edge against both setting blocks and lower into place.
- When glass is properly positioned, remove setting blocks. Take caution to not move glass during setting block removal. Large units may require additional support at the corner mullion to prevent distortion under the weight of the glass.
- Reference shop details and glazing details for non typical conditions.

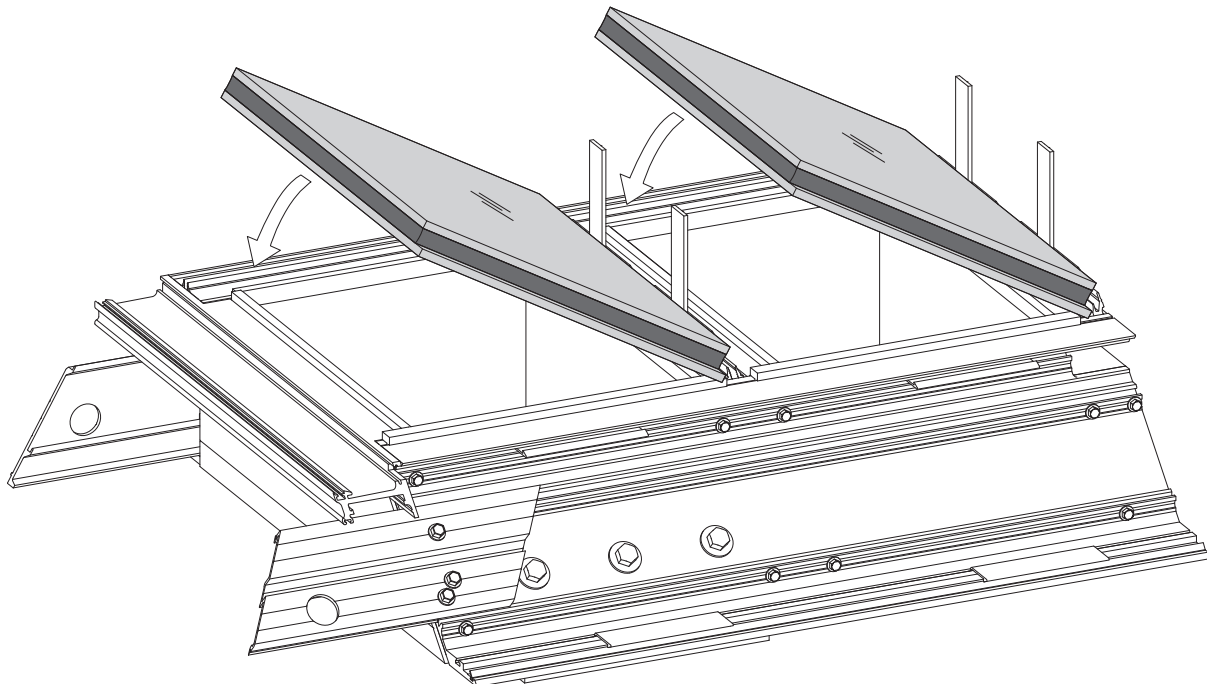
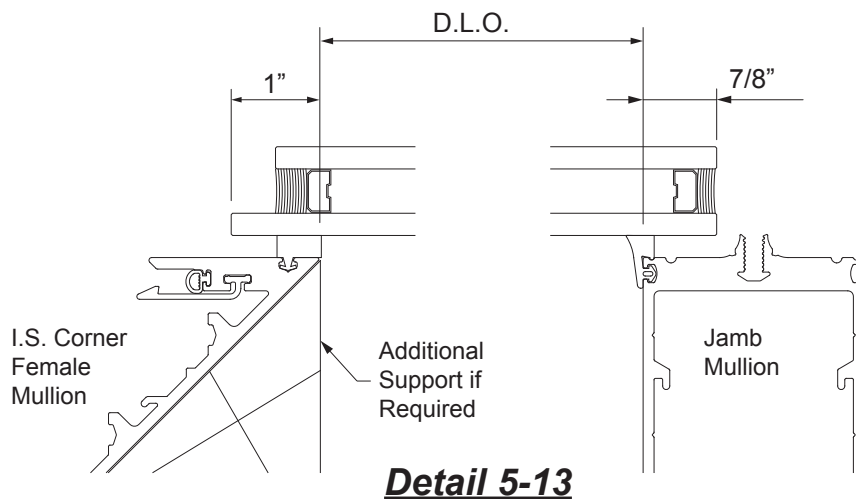

STEP 4: CS5 GLASS INSTALLATION

STEP 4b (Continued) INSTALL GLASS

- Ensure that the glass and metal surfaces are clean and prepared per sealant manufacturer's specifications and recommendations.
- Apply structural silicone sealant completely filling the space between the glass and the mullion. (Slide setting block chairs out of the way temporarily while sealing units.)
- Tool sealant. Clean out any excess sealant in horizontal groove and engagement areas.

See **Detail 5-14**.

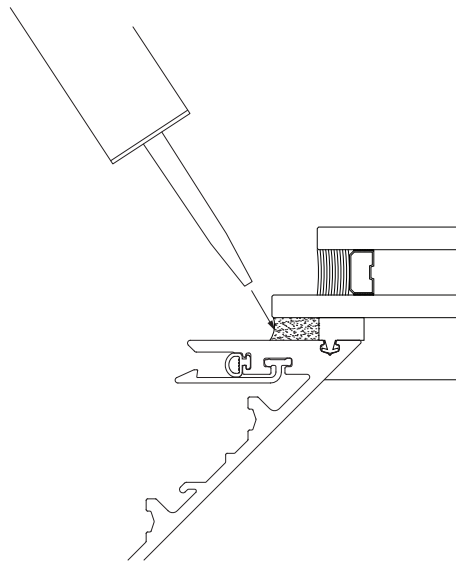

Detail 5-14

STEP 4: CS5 GLASS INSTALLATION

**STEP 4b (Continued)
INSTALL GLASS**

-Apply silicone in I.G.U. cap trace. Rotate and hook in E3-7002 I.G.U. cap. Apply flush with the perimeter edge of the jamb. Tool sealant flush with top of I.G.U. cap.

See **Detail 5-15**.

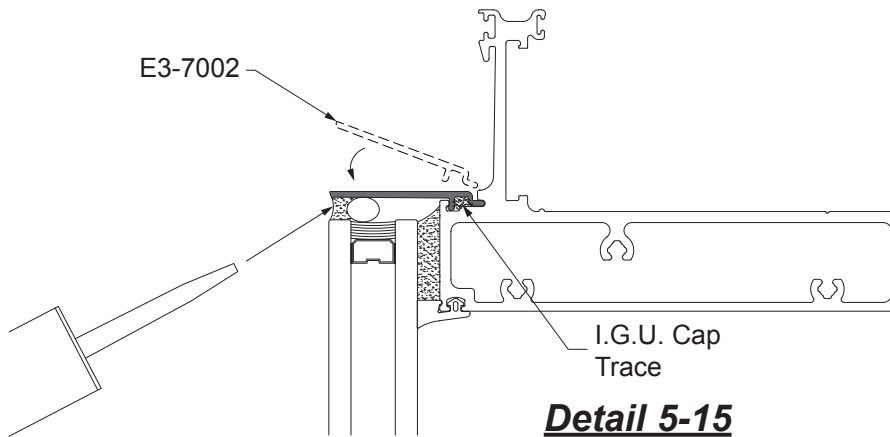

-Push in 3/8" backer rod and seal around the glass and under the I.G.U. cap as shown in **Detail 5-16**. Tool sealant.

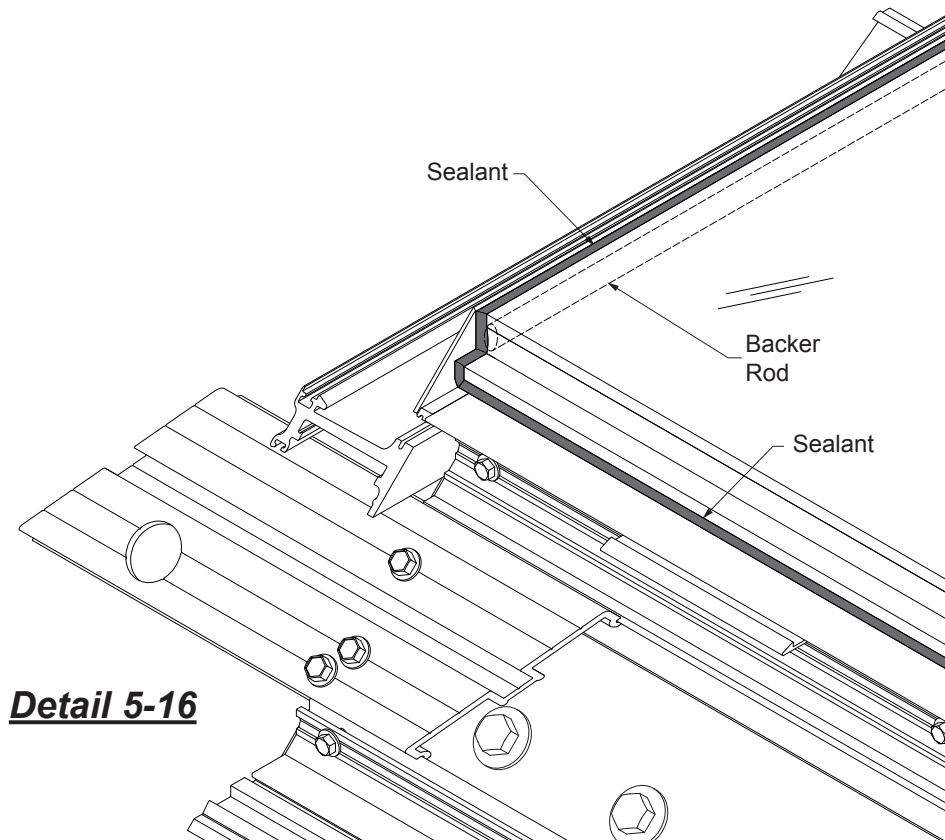

STEP 4: CS5 GLASS INSTALLATION

STEP 4c

INSTALL THERMAL SHIELD

-Before installing the thermal shield (E3-7003 or E3-7016), apply a few dabs of sealant to keep it in place.

-Snap thermal shield into the front of the stacking sill, centered on the D.L.O. See **Detail 5-17**.

-Install backer rods to the joint and completely fill intermediate horizontal and stacking sill joints with sealant as shown on **Detail 5-18**.

Tool excess sealant to ensure a complete seal. Be sure to keep sealant out of horizontal groove and engagement areas.

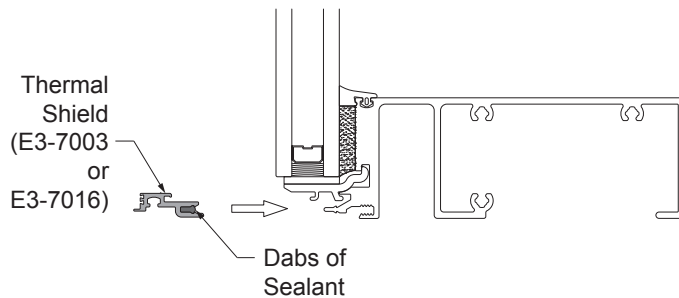

Detail 5-17

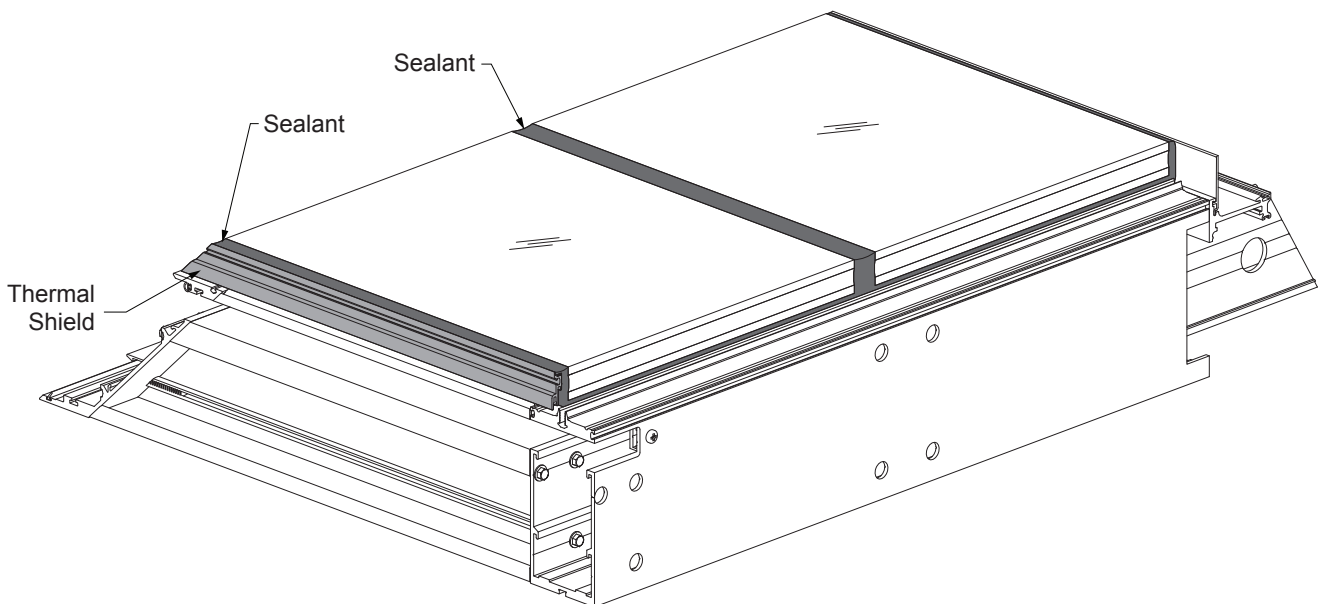

Detail 5-18

STEP 5: CS5 THERMAL BARRIER & WEATHERSEAL INSTALLATION

**STEP 5a
INSTALL JAMB ADAPTOR**

-Refer to **CS1 Thermal Barrier & Cover Installation, Step 5a on Page 18.**

**STEP 5b
INSTALL SSG THERMAL BARRIER & GASKET**

-Snap in SSG Thermal Barrier into the jamb raceway.
-Push in the SSG Wiper Gasket E2-7009 into the SSG thermal barrier. Align according to unit module.
See **Detail 5-19.**

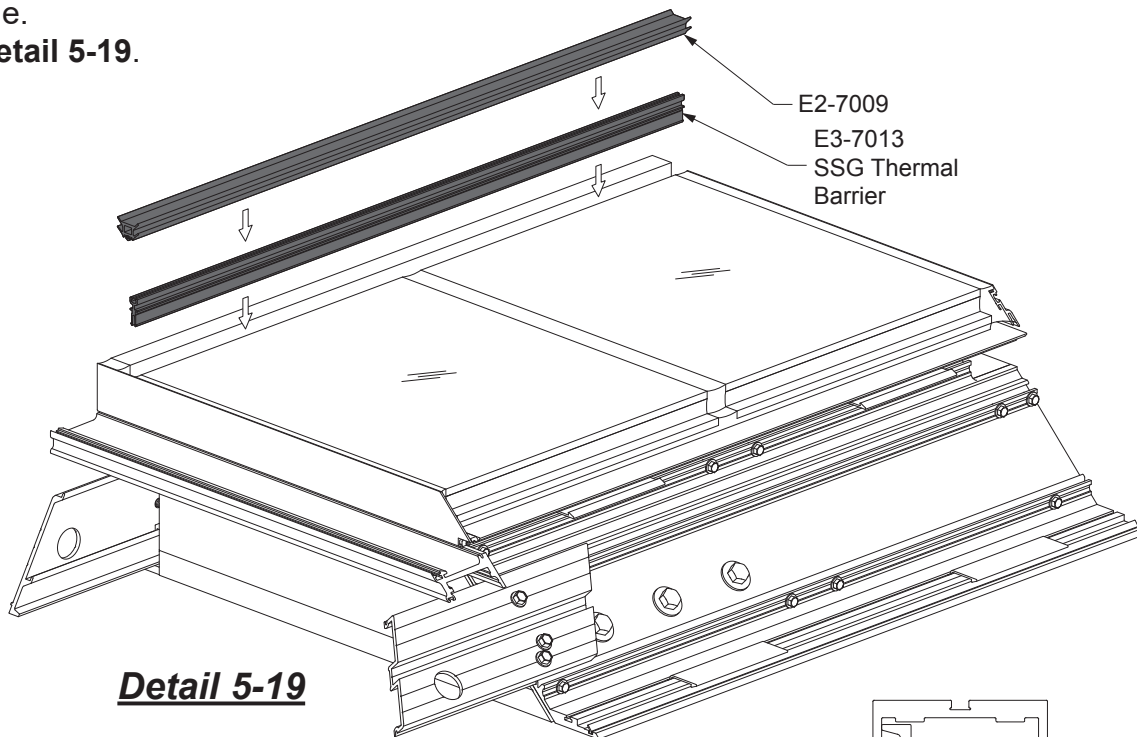

-Apply a dab of sealant at both ends of the gasket and thermal barrier to hold them in place.

See **Detail 5-20.**

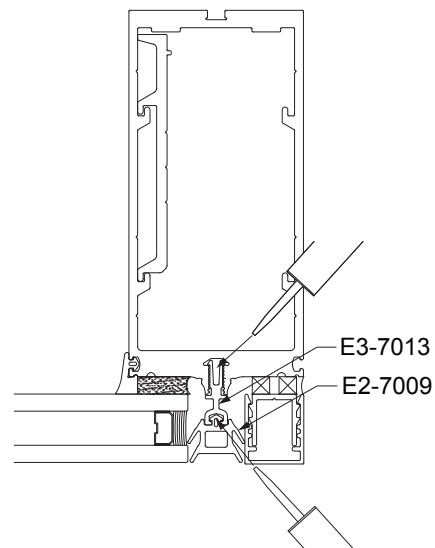

STEP 5: CS5 THERMAL BARRIER & WEATHERSEAL INSTALLATION

STEP 5c

INSTALL STACKING SILL WEATHER SEAL

-Refer to **CS1 Thermal Barrier & Cover Installation, Step 5c** on **Page 20**.

STEP 5: CS5 THERMAL BARRIER & WEATHERSEAL INSTALLATION

STEP 5d

INSTALL STACKING TRAY ACCESSORIES

- Slide in E2-3906 stack isolator into stacking tray as shown in **Detail 5-21**.
- Slide in E2-7004 air/water seal gasket positioned starting at 2" from the perimeter edge of the female mullion and extending flush at the jamb as shown in **Detail 5-22**. Affix the gasket with a small amount of silicone.

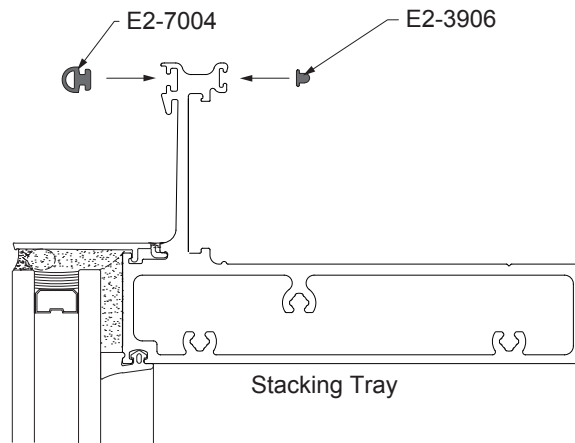

Detail 5-21

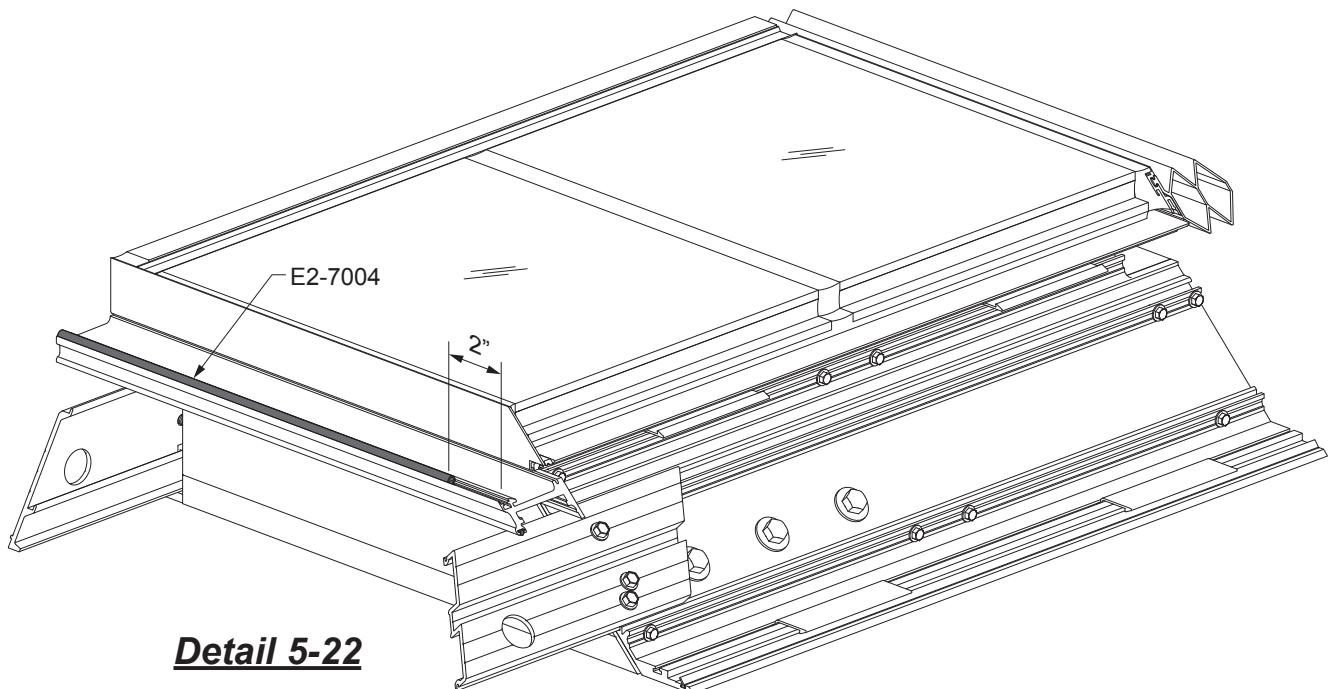

Detail 5-22

 **YKK AP America Inc.**

101 Marietta Street NW

Suite 2100

Atlanta, Georgia 30303

www.ykkap.com