

YCW 752 OGP Outside Glazed Curtain Wall System

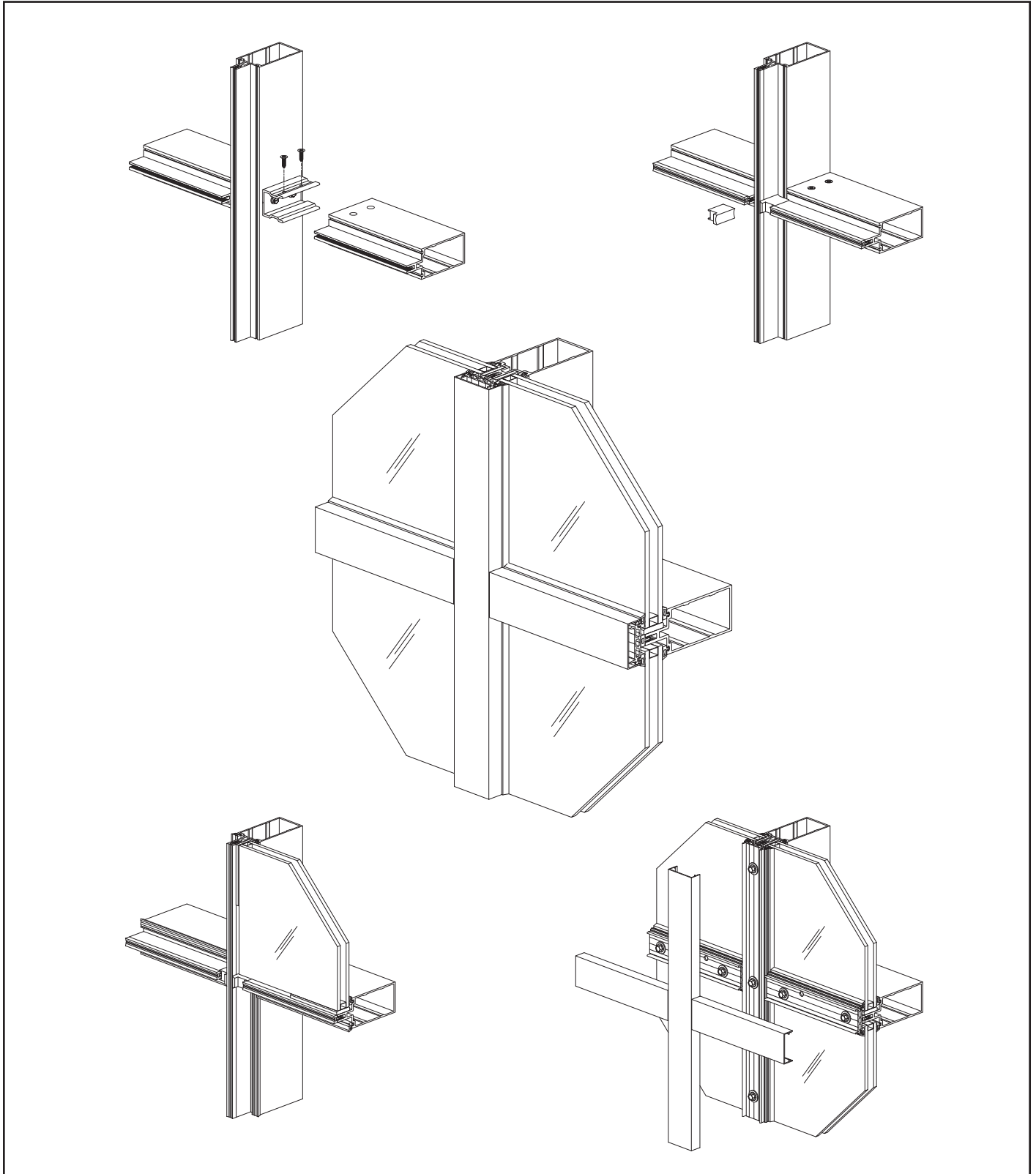

Installation Manual

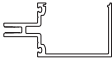

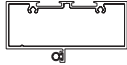







TABLE OF CONTENTS

Installation Notes	Page ii
PARTS DESCRIPTION	
YCW 752 Framing Members	Page 1
YCW 752 Accessories	Pages 2 & 3
YCW 752 Accessories	Page 4
FRAME FABRICATION	
Anchoring Methods/Framing Types	Pages 5 & 6
Fabricate Mullions	Pages 7 to 9
Using Alternate Reinforcing	Page 10
Attach Shear Blocks/Clips for Horizontals	Pages 11 & 12
Fabricate Horizontal Members	Pages 13 to 15
Fabricate Pressure Plates	Page 16
Fabricate Face Covers	Page 17
FRAME INSTALLATION	
Typical Splice	Pages 18 & 19
Install Continuous Perimeter Anchor	Page 20
Jamb/Vertical Installation With Perimeter Anchors	Page 21
Jamb/Vertical Installation With Mullion End Anchors	Pages 22 & 23
Install Wind Load / Dead Load Anchors	Pages 24 to 26
Attach Horizontal Members	Pages 27 to 30
Install Door Subframes	Page 31
Apply Perimeter Sealant	Page 32
Install Thermal Isolator	Page 33
Install Joint Plugs	Page 34
GLAZING	
Install Glazing Adaptors	Page 35
Install Interior Glazing Gaskets	Page 36
Install Setting & Side Blocks	Page 37
Install Perimeter PVC Fillers	Page 38
Install Exterior Glazing Gaskets	Page 38
Install Glass	Page 39
Install Vertical Pressure Plates and Vertical Face Covers	Page 40
Pressure Plate Layout and Assembly	Page 41
Install Exterior Face Covers	Page 42











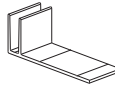

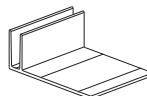

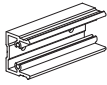
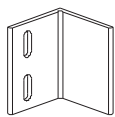

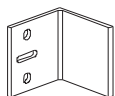

Installation Notes

1. Do not drop, roll or drag boxes of aluminum framing. Move and stack boxes with proper support to prevent distortion. If fork lifts are used be especially careful about striking the boxes when lifting or moving.
2. Store in a dry, out of the way area. If rain exposure, condensation or any water contact is likely, then all packaging material should be removed. Wet packaging materials will discolor and may stain aluminum finishes and paints.
3. All materials should be checked for quality and quantity upon receipt, YKK AP must be notified immediately of any discrepancies in shipment. Check to make sure that you have the required shims, sealants, supplies and tools necessary for the installation.
4. Carefully check the openings and surrounding conditions that will receive your material. Remember, if the construction is not per the construction documents, it is your responsibility to notify the general contractor in writing. Any discrepancies must be brought to the general contractor's attention before you proceed with the installation.
5. Gather your shop drawings, materials, packing list, and this installation manual. Carefully review parts location, the sequence it goes therein, when you glaze it and how you seal it. Installation instructions are of a general nature and may not cover every condition you will encounter. The shop drawings and/or installation manuals were prepared specifically for the product.
6. Any material substitutions must be of equal or greater quality.
7. Make certain that material samples have been sent for compatibility testing for all manufacturer's sealants involved. Make certain sealants have been installed in strict accordance with the manufacturer's recommendations and specifications.
8. Remember to isolate, in an approved manner, all aluminum from uncured masonry or other incompatible materials.
9. System-to-structure fasteners are not supplied by YKK AP. Fasteners called out on shop drawings are to indicate minimum sizes for design loading.
10. If any questions arise concerning YKK AP products or their installation, contact YKK AP for clarification before proceeding.
11. YKK AP storefront and/or curtain wall framing is typically completed before drywall, flooring and other products which may still be in process. Take the extra time to wrap and protect the work produced.
12. Cutting tolerances are plus zero, minus one thirty second unless otherwise noted.
13. Check our website, www.ykkap.com, for the latest installation manual update prior to commencing work.

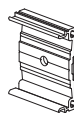

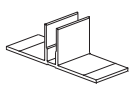
FRAMING MEMBERS

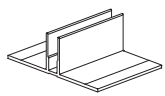
 <p>Mullion / Horizontal 2" x 2-3/4" For 1" Glazing</p>	E9-1612	 <p>Face Cover 2" x 3/4"</p>	E9-7338
 <p>Open Back Head/Sill 2" x 2-3/4" For 1" Glazing</p>	E9-1671	 <p>Glazing Adaptor For 1/4" Glazing of 1" Glazing Pockets</p>	E9-1604
 <p>Flush Filler For E9-1671</p>	E9-1672	 <p>Single Acting Transom Bar Elastomer Weathering E2-0052 Included</p>	AS-0402
 <p>Mullion / Horizontal 2" x 5-1/4" For 1" Glazing</p>	E9-1613	 <p>Door Jamb For 1" Glazing Use with AS-0417</p>	E9-3513
 <p>Open Back Head/Sill 2" x 5-1/4" For 1" Glazing</p>	E9-1670	 <p>Door Jamb For 1/4" Glazing Use with AS-0417</p>	E9-3218
 <p>Flush Filler For E9-1670</p>	E3-3162	 <p>Snap-In Door Stop Elastomer Weathering E2-0051 Included, Use with E9-3513 or E9-3218</p>	AS-0417
 <p>Polyamide Pressure Plate For 1" Glazing</p>	AS-3618	 <p>Perimeter Anchor For 1" Glazing</p>	E9-1642
 <p>PVC Perimeter Adaptor For 1" Glazing</p>	E3-3665	 <p>Perimeter Channel For 1" Glazing</p>	E9-1643





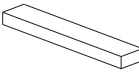
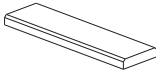

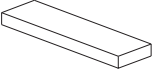



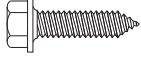

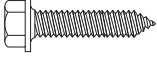

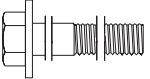
ACCESSORIES

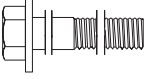
	Shear Block For E9-1612 Use (2) HF-2510-W1 & (2) FC-1212	E1-1262		Jamb Mullion End Anchor For E9-1612	E1-3557
	Shear Block For E9-1613 & E9-1659 Use (2) HF-2510-W1 & (2) FC-1212	E1-1250		Jamb Mullion End Anchor For E9-1613 & E9-1659	E1-1296
	Optional Concealed Fastener Shear Block For E9-1612, Use (2) HF-2510-W1 & (2) FC-1220	E1-3537		Mullion End Cap 2" x 2-3/16" x 0.050"	E1-1290
	Optional Concealed Fastener Shear Block For E9-1613 & E9-1659, Use (2) HF-2510-W1 & (2) FC-1220	E1-3538		Wind Load Anchor Steel with Zinc Oxide Paint Refer to Shop Drawings for Anchor Dimensions	E1-1204* Project Specific
	Shear Clip For E9-1612 (End Anchors) Use (2) HF-2510-W1 & (2) FC-1212	E1-3554		Dead Load Anchor Steel with Zinc Oxide Paint Refer to Shop Drawings for Anchor Dimensions	E1-1205* Project Specific
	Shear Clip For E9-1613 & E9-1659 (End Anchors), Use (2) HF-2510-W1 & (2) FC-1212	E1-1264		Jamb Anchor Tap Plate 3" x 6" x 5/16" Thk.	E1-3536
	Mullion Joint Sleeve For E9-1612	E1-3558		Anchor Slip Pad For Dead Load & Wind Load Anchors	E3-0103
	Mullion Joint Sleeve For E9-1613 & E9-1659	E1-1251		Temporary Glass Retainer	E1-3012
	Face Cover Splice Sleeve For E9-7338	E1-1274		Thermal Isolator Use with Polyamide Pressure Plate	E2-0266
	Intermediate Vertical Mullion End Anchor For E9-1612	E1-3556		Standard Joint Plug For 1" Glazing	E2-0138
	Intermediate Vertical Mullion End Anchor For E9-1613 & E9-1659	E1-1295		Joint Plug For Slide-In Mullion 1" Glazing Use with E2-0146 E-Slot Plug	E2-0149

ACCESSORIES

 <p>E-Slot Plug For Slide-In Mullion 1" & 1/4" Glazing</p>	<p>E2-0146</p>	 <p>Setting Block For 1/4" Glazing With Pressure Sensitive Adhesive</p>	<p>E2-0623</p>
 <p>Setting Block For 1" Glazing With Pressure Sensitive Adhesive</p>	<p>E2-0134</p>	 <p>Glazing Gasket</p>	<p>E2-0120</p>
 <p>Side Block For 1" Glazing With Pressure Sensitive Adhesive</p>	<p>E2-0133</p>		

FASTENERS

	#8 x 3/8" PHSMS Type AB, Zinc Plated Steel For Attachment of Glazing Adaptor E9-1604	PC-0806		1/4"-20 x 1" HWHS Type CA, Stainless Steel, For Attachment of Temporary Glass Retainer	HD-2516 -W3-SS
	#8 x 1/2" PHSMS Type F Stainless Steel For Securing of Vertical Face Covers to Pressure Plates	PF-0808 -SS		1/4"-20 x 1-1/4" HWMS Type CA, Stainless Steel For Attachment of Pressure Plate to Mullion	HD-2520 -W3-SS
	#8 x 1/2" FHSMS Type AB, Zinc Plated Steel Undercut For Attachment of Face Cover Splice Sleeve	FC-0808		1/2"-13 x 2" HWMS Zinc Plated Steel, For Attachment of Windload/ Deadload Anchor at Jamb	HM-5032
	#12 x 3/4" FHSMS Type AB, Zinc Plated Steel For Attachment of Horizontal to Shear Block/Clip	FC-1212		1/2"-13 x 4-1/2" HWMS Zinc Plated Steel, For Attachment of Windload/ Deadload Anchor at Mullion	HM-5072
	#12 x 1-1/4" FHSMS Type AB, Zinc Plated Steel For Attachment of Horizontal to Concealed Shear Block	FC-1220		1/2"-13 Nut HHMS Zinc Plated Steel For Attachment of Mid-Anchors (Wind Load / Dead Load)	HM-5000
	#14 x 5/8" FHSMS Type AB, Zinc Plated Steel For Attachment of Mullion End Cap E1-1290	FC-1410		1/2" Flat Washer Zinc Plated Steel, For Attachment of Mid-Anchors (Wind Load / Dead Load)	WW-5000
	1/4"-20 x 5/8" HWHS Type F, Zinc Plated Steel For Attachment of Shear Block/Clip to Vertical	HF-2510 -W1		1/2" Lock Washer Zinc Plated Steel, For Attachment of Mid-Anchors (Wind Load / Dead Load)	WS-5000
	1/4"-20 x 1" HWHS Type F, Zinc Plated Steel For Shear Block/Clip Attachment w/ Steel Reinf.	HF-2516 -W1		1/4" Fender Washer Stainless Steel, Used w/ HD-2520-W3-SS	FW-2500- SS

FRAME FABRICATION

FRAME TYPES / ANCHORING METHODS

The following is a guideline for common types of frames. Refer to shop drawings for exact layout of frames.

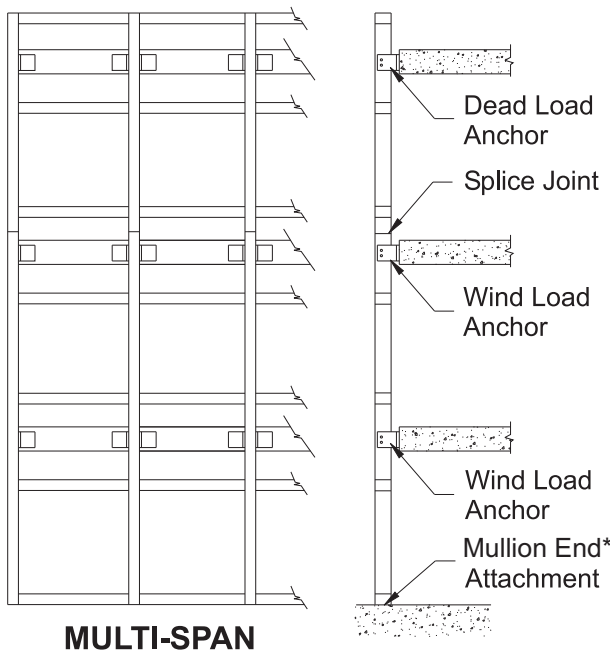
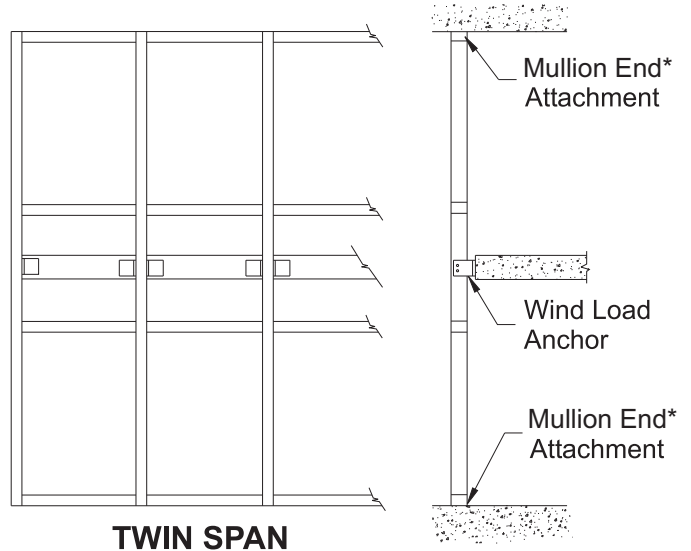
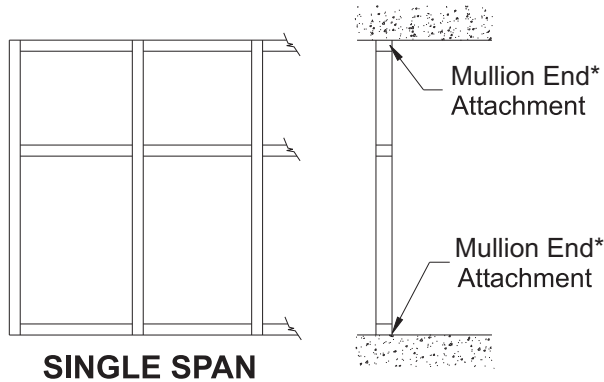

Smaller units may be assembled on the ground and tipped in place. Larger units require being stick assembled in place.

Note: If YKK does not prepare the shop drawings for the project, a qualified engineer must approve all anchors, their arrangement, and mullion selection.

All anchors must be attached to structurally sound material that will accommodate the anchor reactions.

* Mullion end attachment will be continuous perimeter anchor or mullion end anchor.

Fabrication of YCW 752 varies depending on the type of mullion end attachment required for a given project:

Perimeter Anchors are for low load anchoring conditions (maximum 500 lb. end load reaction):
E9-1642, E9-1643, & E9-1644

Mullion End Anchors "F" & "T" are for high load conditions: E1-3556, E1-3513, E1-1295, E1-3557, E1-3514, & E1-1296

FRAME FABRICATION

FRAME TYPES / ANCHORING METHODS

Using Perimeter Anchors:

-Vertical mullions must be notched as shown in **Detail 1** on **Page 7**.

Using Mullion End Anchors:

YCW 752 has two possible end anchoring conditions: "T" and "F".

- "T" anchors are used with intermediate verticals at the head and sill.
- "F" anchors are used with jamb mullions at the head and sill.
- "Door Jamb" anchors are used with mullions at a door jamb and are specified by the approved shop drawings or P.E. calcs.
- Anchor usage depends on end reaction, stress, and attachment.

Mullions should be pre-assembled with shear blocks/clips, end anchors, and steel or aluminum reinforcing if necessary.

Framing Members for Stick Build:

- Head and sill members must be notched as shown in **Detail 7** on **Page 14** to clear the mullion end anchors.
- Intermediate horizontal members at end bays must be E-Slotted to clear shear blocks as shown in **Detail 8** on **Page 15**.

Note: When using stick build construction, check overall frame width every fifth mullion as the wall is installed to prevent the buildup of cumulative tolerance errors.

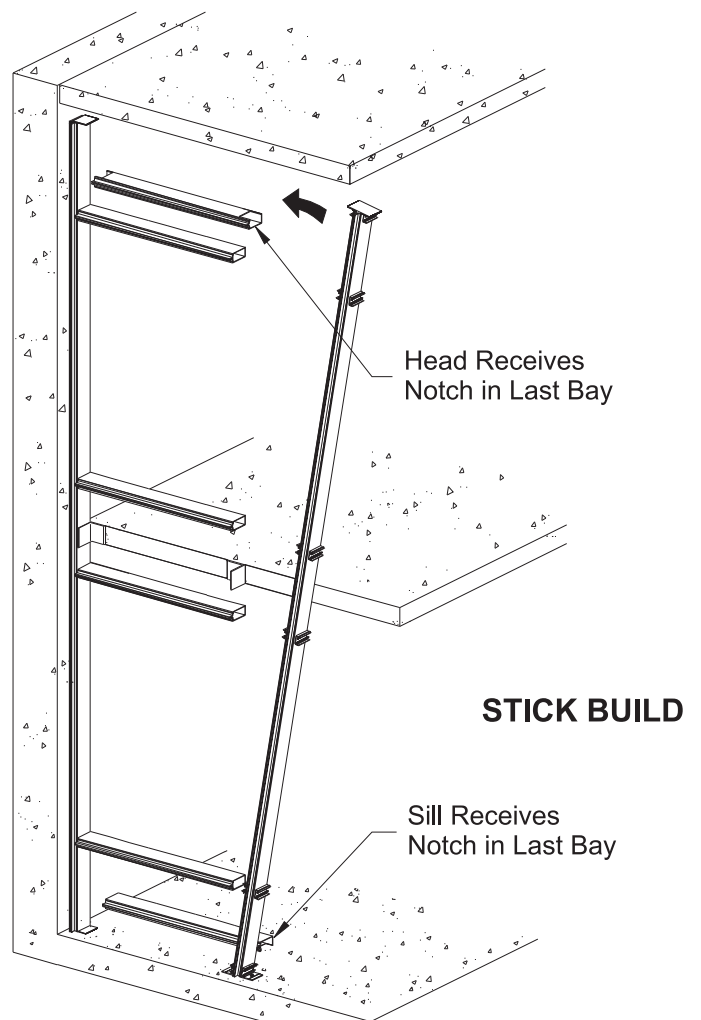

FRAME FABRICATION

FABRICATE MULLIONS

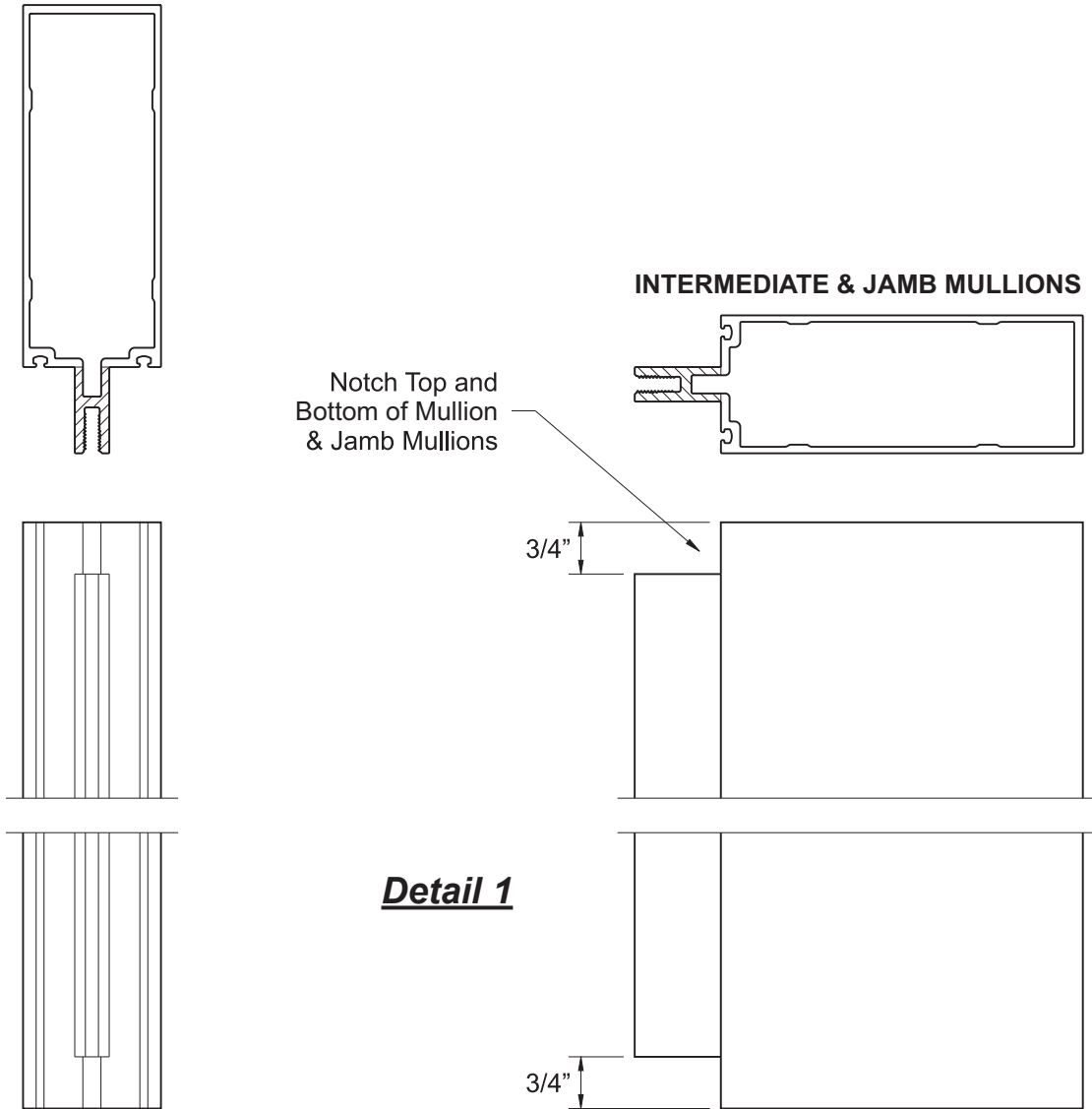

Step 1

-Cut all intermediate and jamb mullions to dimensions as shown on shop drawings. Allow for 1/2" caulk joint around the frame & 1/2" joint at vertical splices.

Note: Mullions at door jambs are sealed against the substrate at the sill without a shim space at that location.

Step 2

-If you are using continuous perimeter anchors, E9-1642 or E9-1643, the top and bottom of mullion and jamb mullions must be notched as shown in **Detail 1**.

Note: Do not notch verticals when using mullion end anchors: "T" or "F".

FRAME FABRICATION

STEP 3 FABRICATE MULLIONS

- Mullion hole locations for shear blocks and shear clips are shown below.
- Drill 0.213" dia. (#3 drill bit) holes for shear block/clip attachment at the locations indicated.

See **Detail 2**.

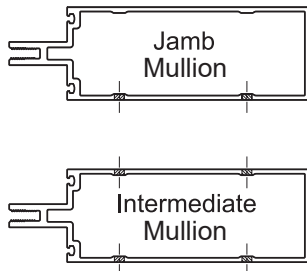

Dim "A"	Dim "B"
5-1/4"	2-3/4"
2-3/4"	1"

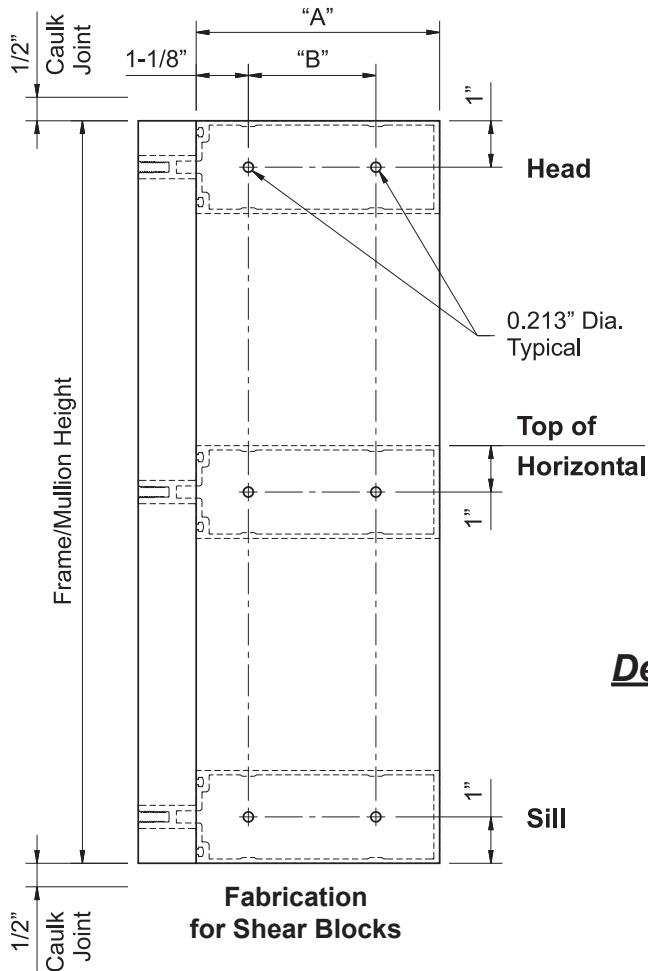
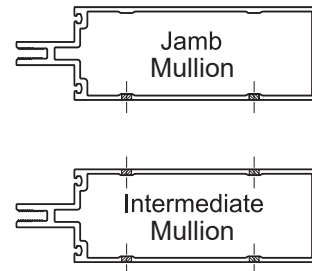

Detail 2

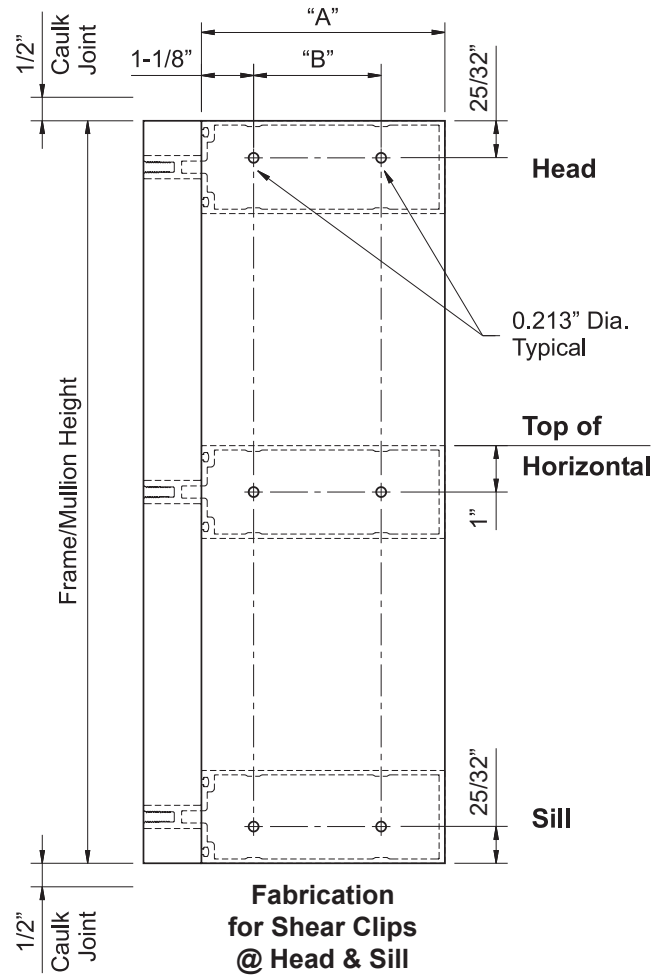

FRAME FABRICATION

STEP 3 (Continued)
FABRICATE MULLIONS

-Mullions used at door jambs require a different fabrication as are sealed flat against the floor.
See **Detail 2A**.

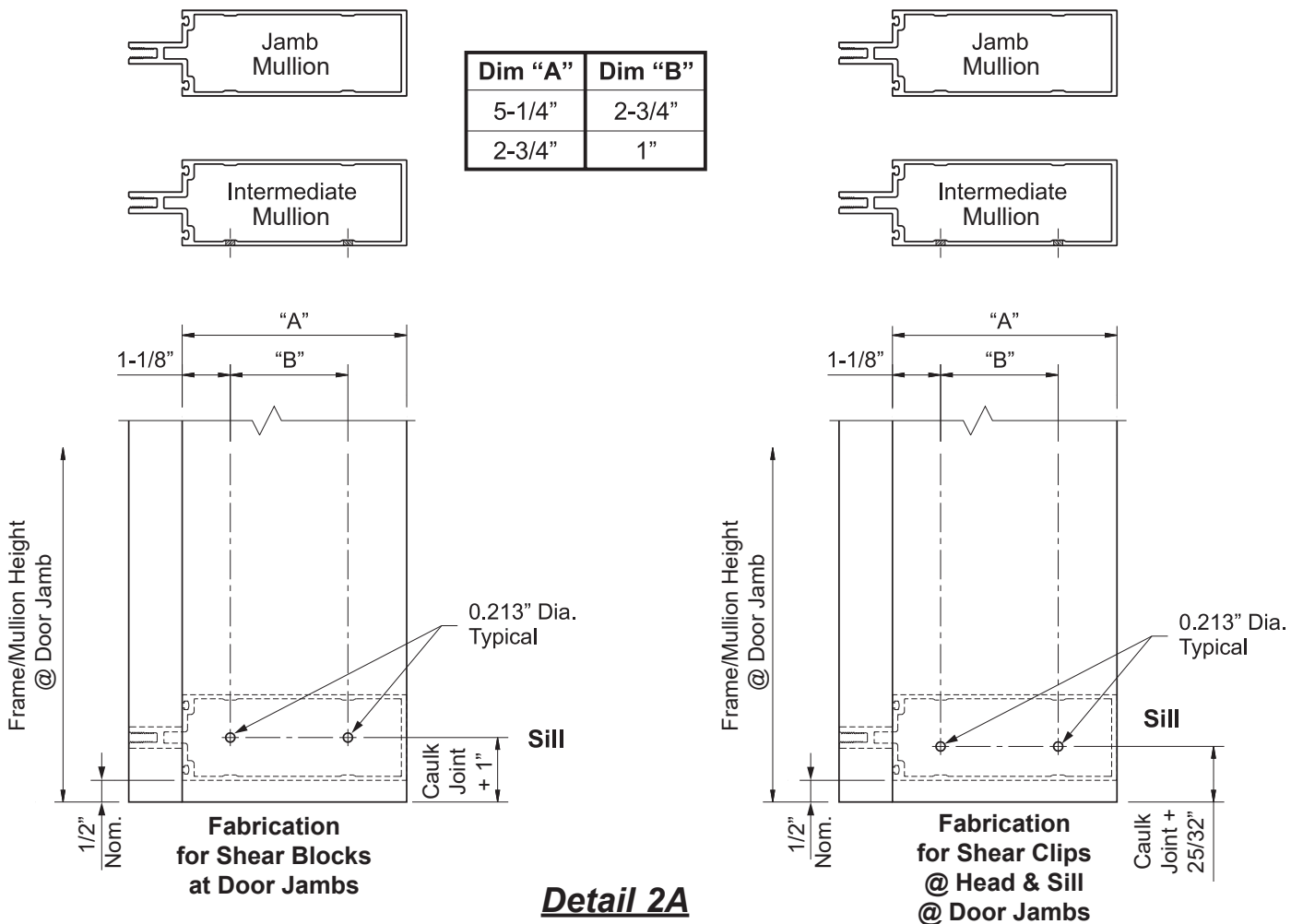

FRAME FABRICATION

STEP 4 USING ALTERNATE REINFORCING

If your engineering calculations require the mullions to be reinforced with either steel or aluminum, secure the reinforcing to the vertical using the appropriate fasteners.

- Start 3" from both ends of the mullion and install a fastener on both sides of the mullion tongue.
- Stagger the fasteners on either side of the tongue going up the vertical.
- Seal all screw heads with sealant.

Note: Exact size of reinforcing, size and location of fasteners to be determined by a qualified engineer.

Optional reinforcing is also attached on the sides of the mullion with the attachment of shear blocks.

- Drill 0.281" dia. (9/32 bit) clear holes in the mullion only.
- Match drill 0.213 dia. (#3 bit) tap holes in the reinforcing only.
- Attach the shear blocks with HF-2516-W1 fasteners.

See **Detail 3**.

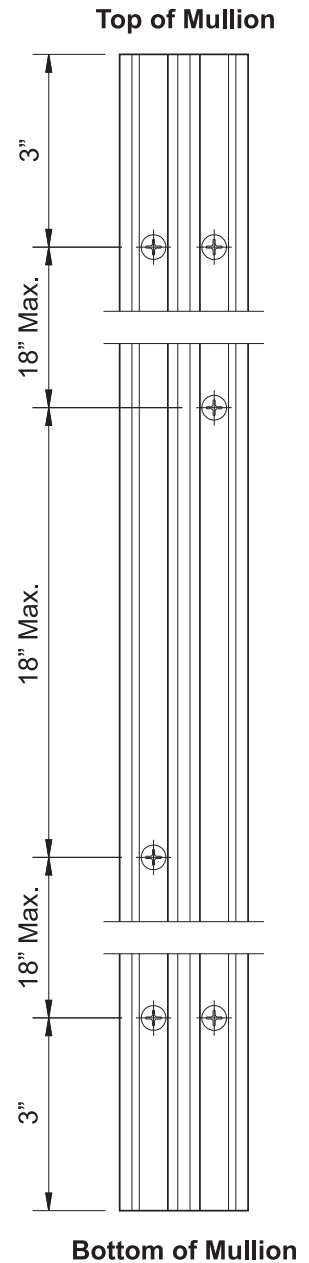
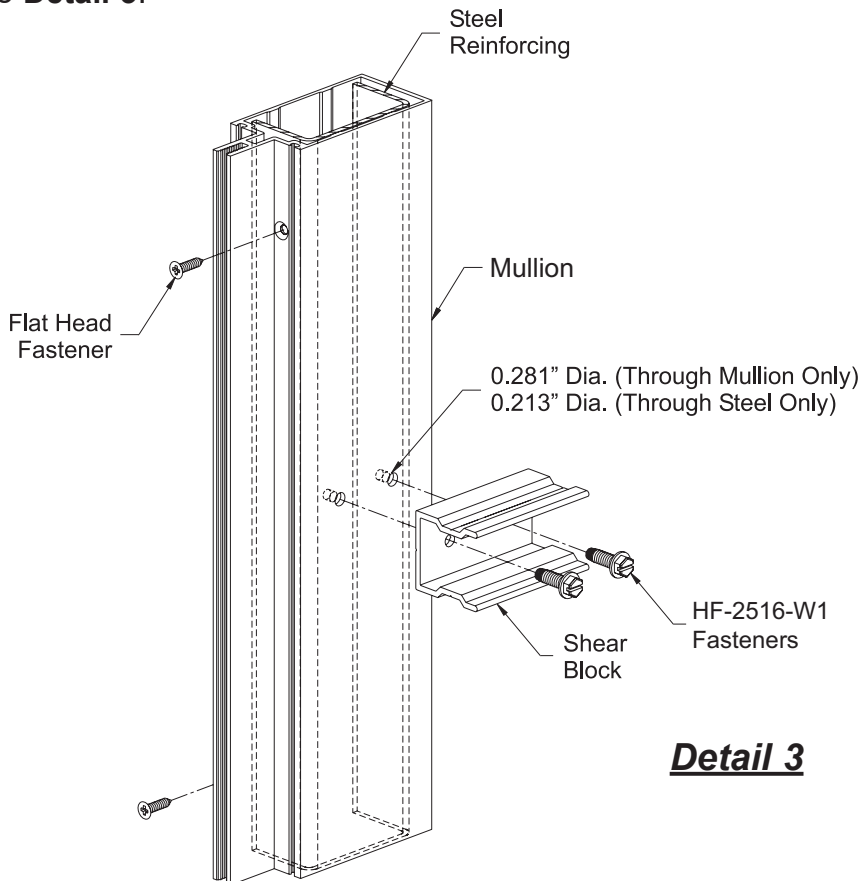

FRAME FABRICATION

STEP 5

ATTACH SHEAR BLOCKS/CLIPS TO HORIZONTALS

-Attach the shear blocks/clips to jambs and verticals with two HF-2510-W1 fasteners per block. Refer to the chart below for the proper part numbers to be used for the given mullions.

Note: See **Step 4** on the previous page when using alternate reinforcing.

For Frames With Perimeter Anchors:

-Head, intermediate horizontal, and sill members are attached using shear blocks.

For Frames With Mullion End Anchors:

-Intermediate horizontal members are attached using shear blocks.

-Head and sill members are attached using shear clips.

See **Detail 4** on the next page.

Note: Optional concealed fastener shear blocks can be used only at the intermediate horizontals.

Mullion	Shear Block	Shear Clip
E9-1613	E1-1250 (E1-3538 optional)	E1-1264
E9-1612	E1-1262 (E1-3537 optional)	E1-3554

FRAME FABRICATION

**STEP 5 (Continued)
ATTACH SHEAR BLOCKS/CLIPS TO HORIZONTALS**

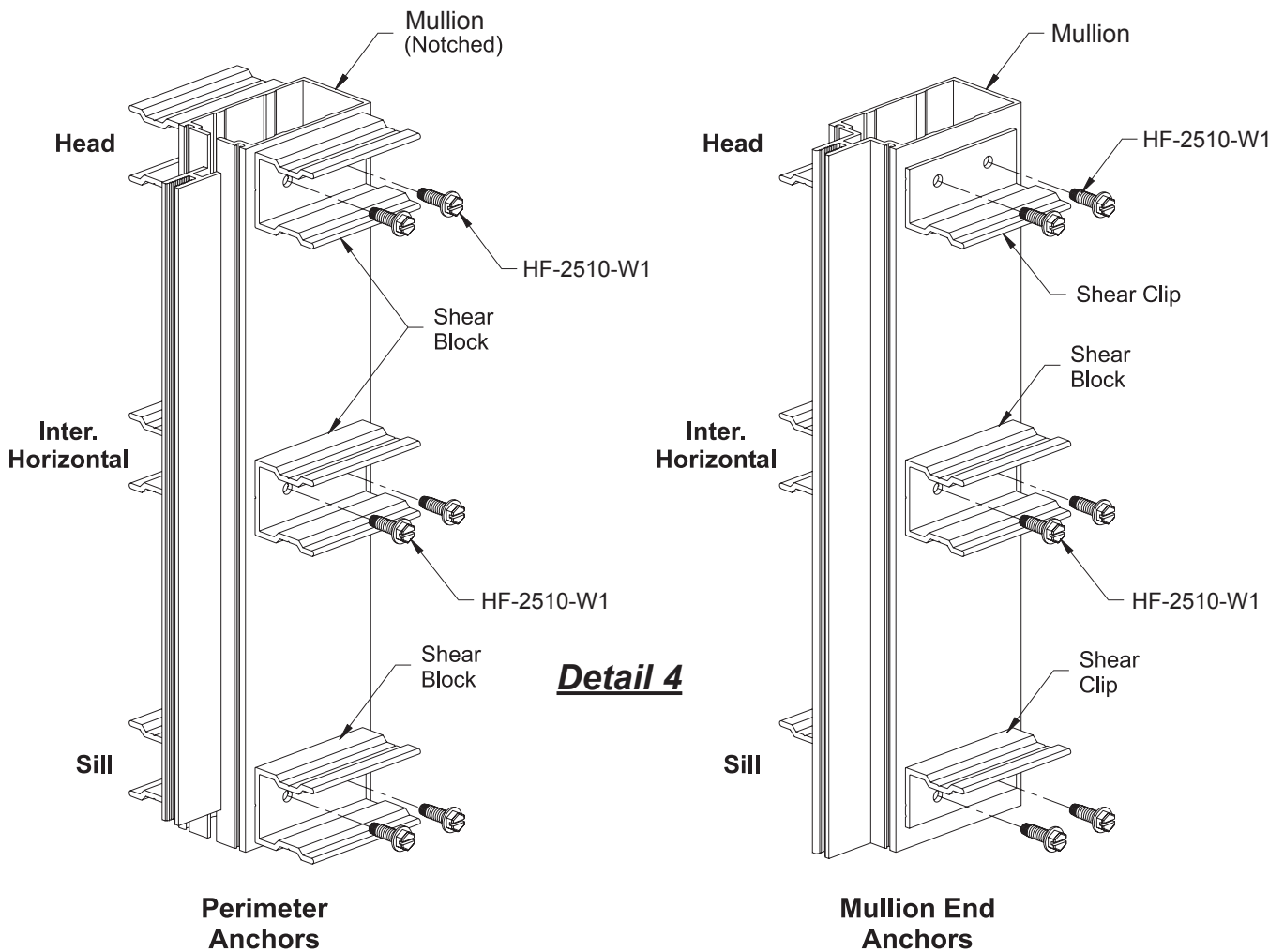

FRAME FABRICATION

STEP 6
FABRICATE HORIZONTAL MEMBERS

- Cut all horizontal members to the daylight opening as shown in shop drawings.
 - Horizontal members must be fabricated as shown below to attach to shear blocks/clips.
 - Layout hole locations on the top of the horizontal at both ends as shown below.
 - Drill 0.236" diameter (#B bit) holes and countersink for #12 flat head fasteners.
- See **Detail 5**.

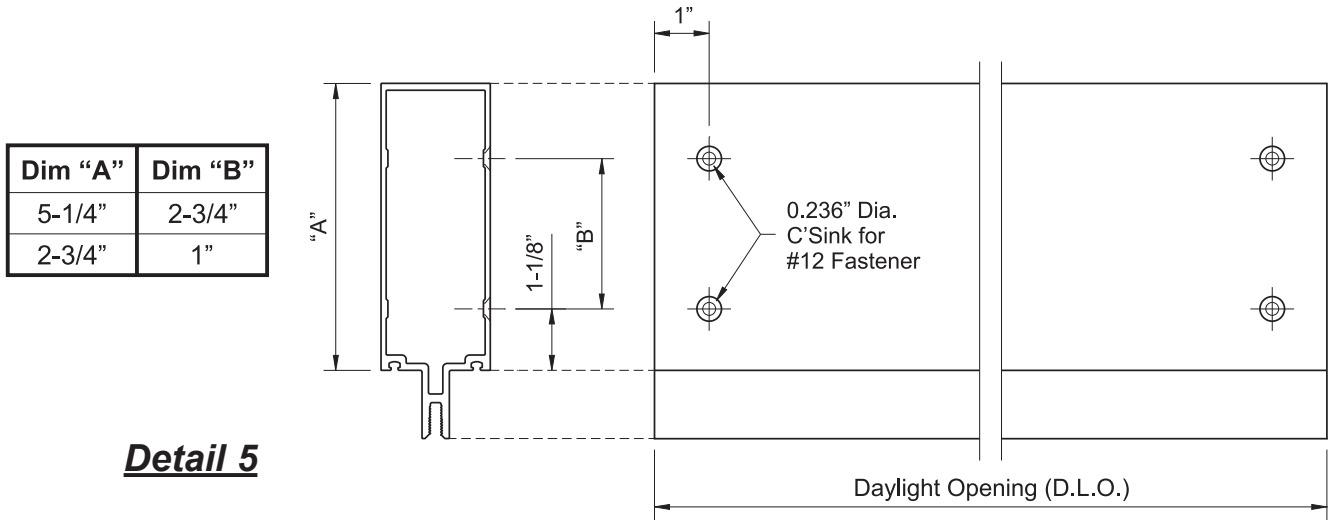

If Optional Concealed Fastener Shear Blocks Are Used:

- Cut all horizontal members to the daylight opening as shown in shop drawings.
- Horizontal members must be fabricated as shown below to attach to shear blocks.
- Layout hole locations on the face of the horizontal at both ends as shown below.
- Drill 0.236" diameter (#B bit) holes and countersink for #12 flat head fasteners.

See **Detail 6**.

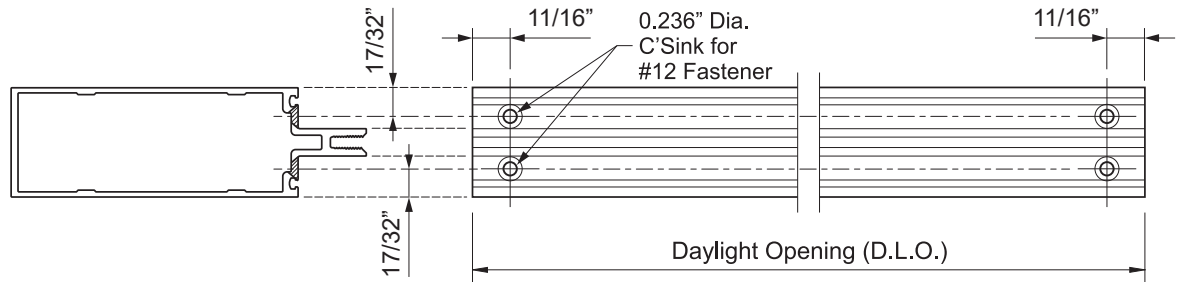

FRAME FABRICATION

**STEP 6 (Continued)
FABRICATE HORIZONTAL MEMBERS**

**If Mullion End Anchors Are Used
Tubular Head and Sill Members Require Additional Fabrication:**

-Head and sill members must be notched out at each end to clear mullion end anchors and anchor bolts.

-See **Detail 7** below for notch dimensions.

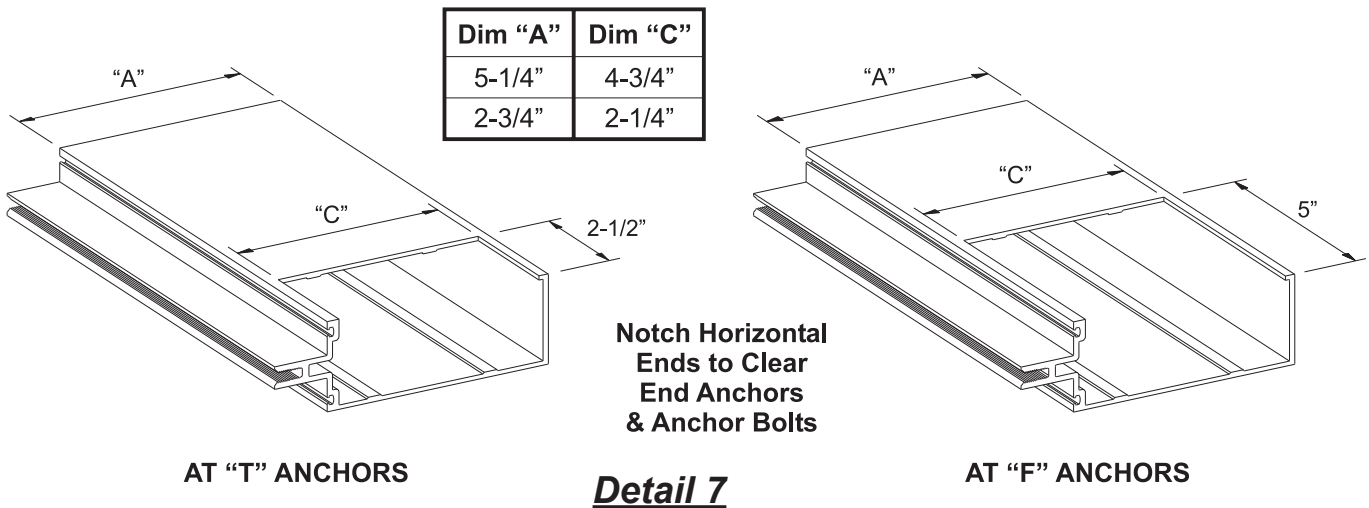

**If Mullion End Anchors Are Used
Open Back Head and Sill Members Require Additional Fabrication:**

-Open back head & sill members require holes to access anchor bolts.
-Drill 1-1/2" diameter holes at anchor locations as required by approved shop drawings or engineering calculations.

-See **Detail 7a** below for notch dimensions.

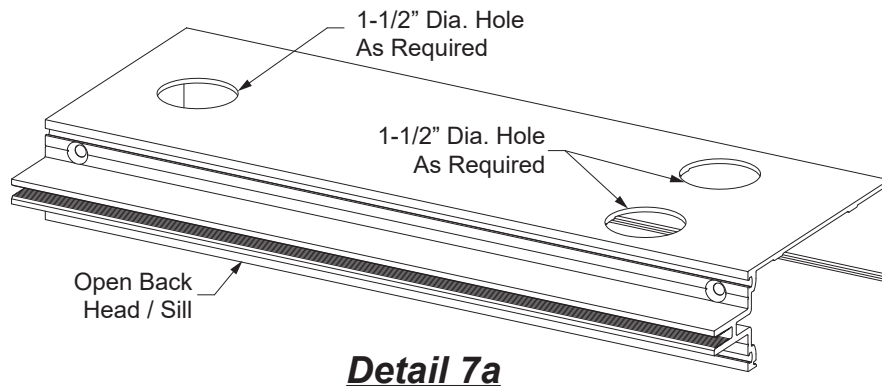

FRAME FABRICATION

STEP 6 (Continued)
FABRICATE HORIZONTAL MEMBERS

Horizontals at End Bays (E-SLOT):

When stick building the frame, horizontals at end bays must slide in from the interior. In order to clear the shear blocks on the verticals:

-Notch the face and tongue of the horizontal at both ends as shown below.

See **Detail 8**.

Note: Optional concealed fastener shear blocks cannot be used at E-slots.

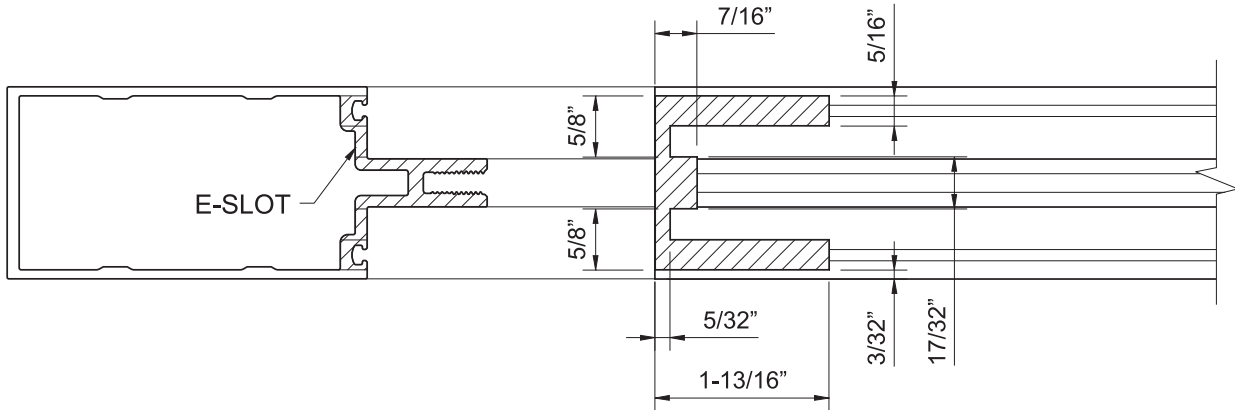

Detail 8

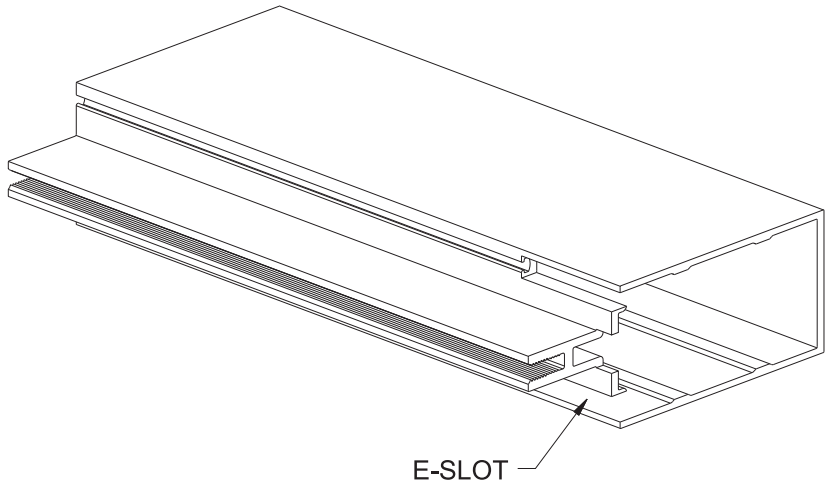

FRAME FABRICATION

STEP 7 FABRICATE PRESSURE PLATES

Horizontal Pressure Plates:

- Cut all head, sill, and intermediate horizontal pressure plates to the daylight opening between verticals minus(-) 1/2".
- Pressure plate stock lengths have 0.281" dia. holes drilled every 8" on center. After cutting, drill additional holes if required to ensure that end holes are 1-1/2" from each end.
- If factory drilled holes are less than 1-1/2" from the ends, interior and exterior holes must be sealed and tooled smooth.

Note: For vertical pressure plates below splice, drill a 0.281" diameter fastener hole 4" from the upper end of the pressure plate. See **Detail 12** on **Page 19** for more information.

- Using a 5/16" dia. spade drill bit, drill two 0.313" (5/16") diameter weep holes 3" from each end and one at the centerline of the pressure plate. If the space between the weep holes exceeds 3', additional weep holes should be drilled to ensure that there is no more than 3' between the weep holes.

See **Detail 9**.

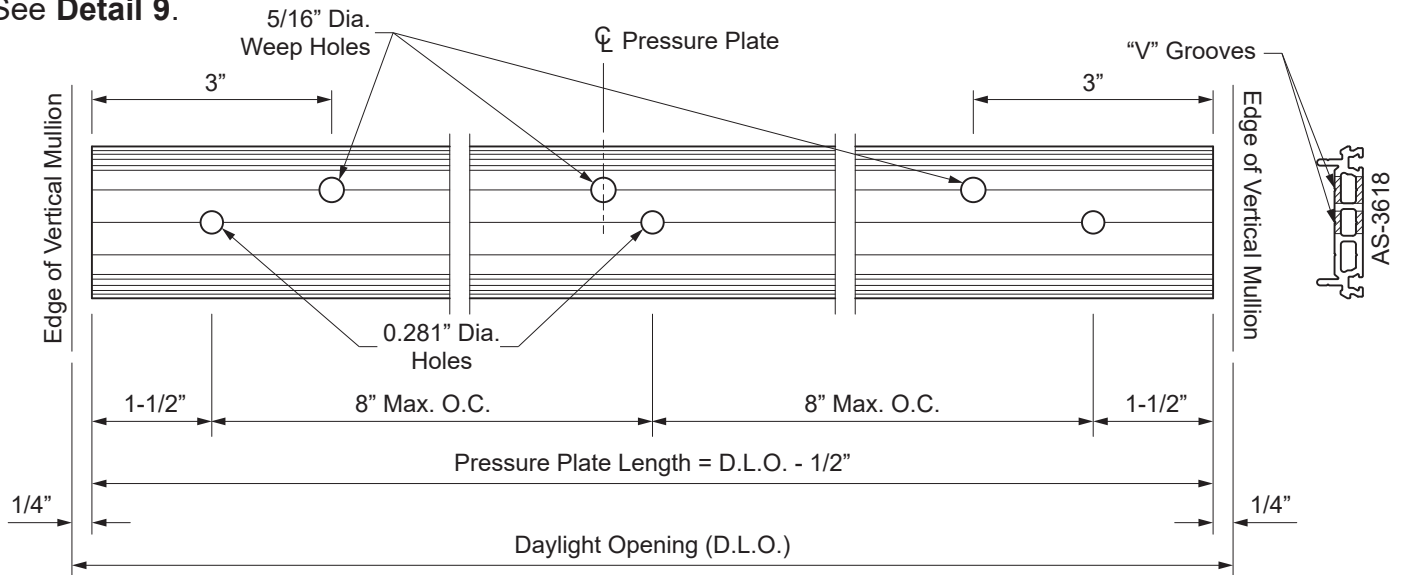

Detail 9

Horizontal Pressure Plates:

- Apply and tool sealant into both ends of pressure plate hollows.
- See **Detail 9a**.

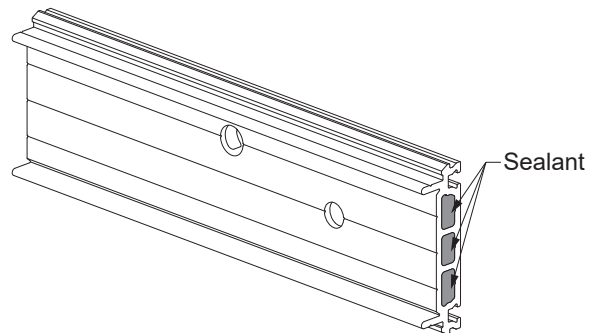

Detail 9a

FRAME FABRICATION

STEP 7 (Continued)
FABRICATE PRESSURE PLATES

Vertical Pressure Plates:

- Cut vertical and jamb pressure plates and thermal isolators to the same length as the vertical mullions.
- If vertical mullions are spliced, cut pressure plates to accommodate for 1/2" expansion joint as shown in **Step 9** on **Pages 18 & 19**. Apply and tool sealant into the hollows of both pressure plates at the splice joint.
- Drill additional attachment holes if required to ensure that end holes are within 1-1/2" of each end.

STEP 8
FABRICATE FACE COVERS

Horizontal Face Covers:

- Cut horizontal face covers to the daylight opening between verticals minus(-) 1/16".
 - Drill two 0.313" diameter weep holes at 1/3 points of cover as shown below.
- See **Detail 10**.

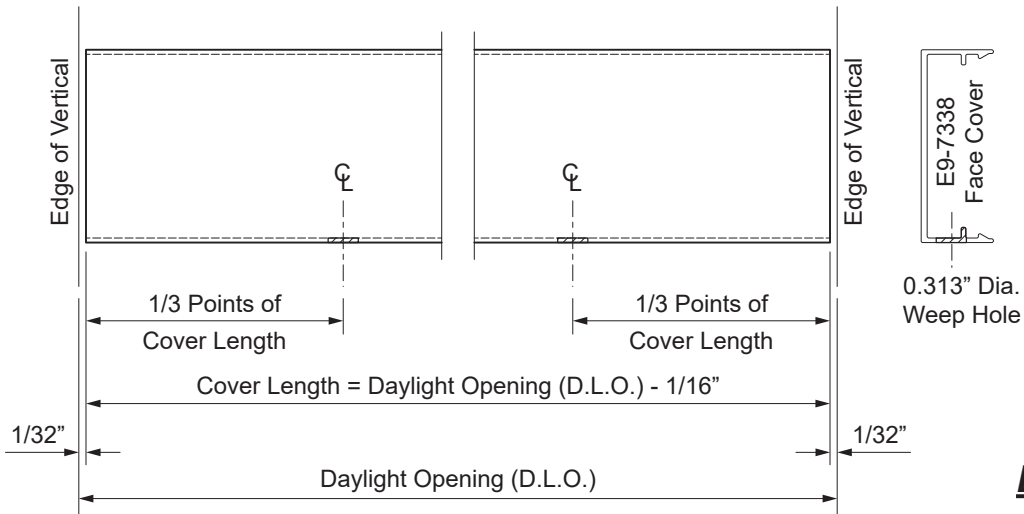

Detail 10

Vertical Face Covers:

- Cut vertical face covers to the same length as the mullions unless the mullions are spliced.
- If mullions are spliced, cut vertical covers to accommodate for the 1/2" expansion joint as shown in **Step 9** on **Pages 18 & 19**.

FRAME INSTALLATION

**STEP 9
TYPICAL MULLION SPLICE**

Stagger Mullion, Pressure Plate, & Cover Splice Joints as Shown Below In Detail 11:

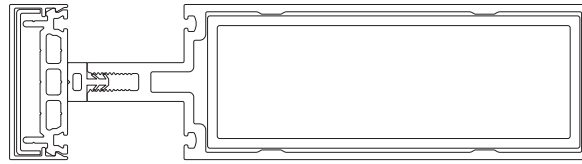
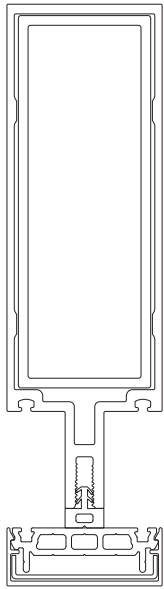

Detail 11

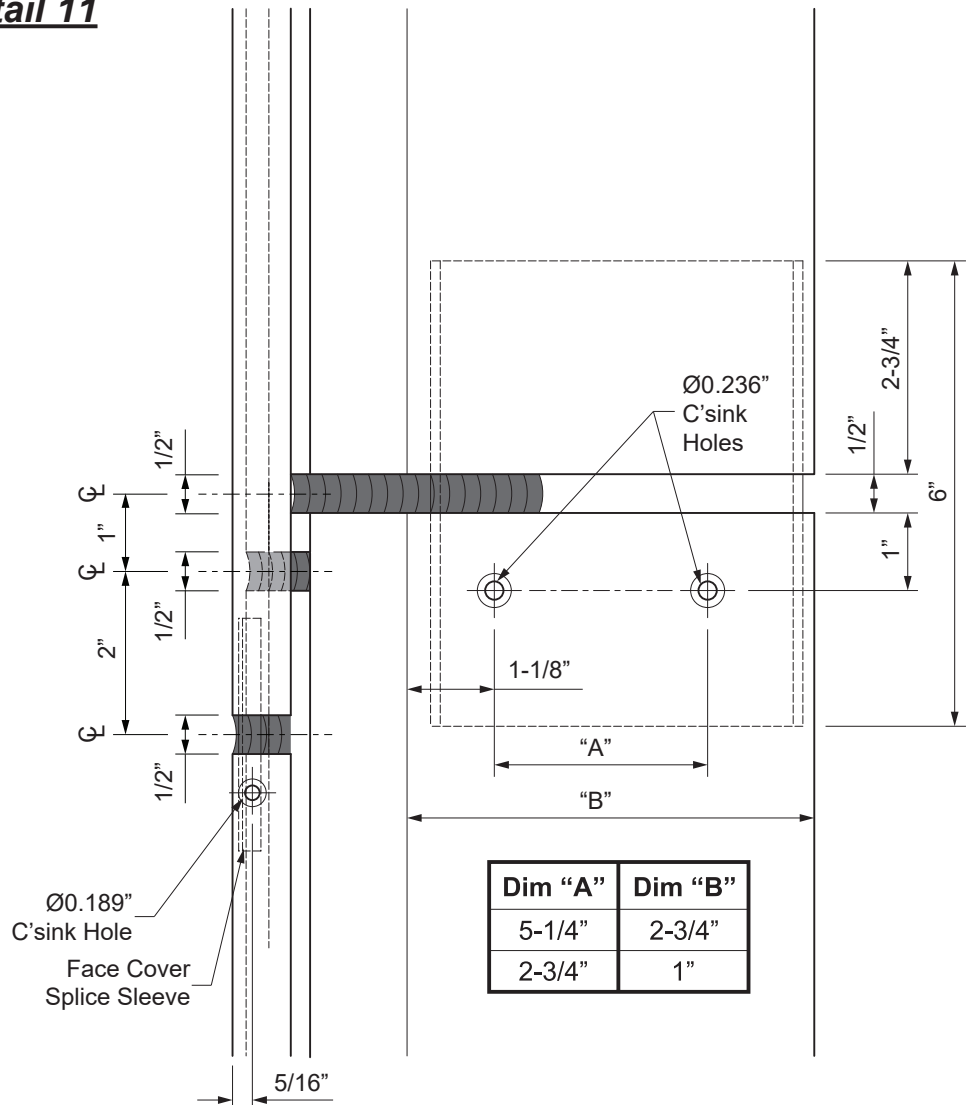
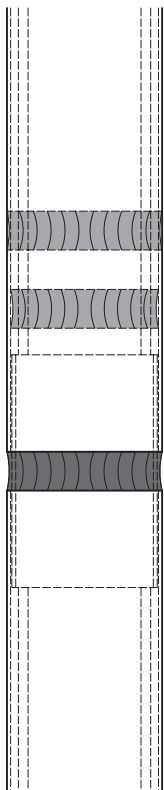

FRAME INSTALLATION

STEP 9 (Continued) TYPICAL VERTICAL SPLICE

- Clean all surfaces as recommended by sealant manufacturer.
- Apply bond breaker tape to the face of the splice sleeve at its midpoint (3" from top or bottom).
- Lower the splice sleeve into top of lower mullion 2-3/4" and attach with two FC-1212 fasteners on both sides of the mullion as shown below in **Detail 12**.
- When using 1" glazing mullions, stuff a small piece of backer rod 1/2" down the cavity behind mullion tongue and pump in sealant to fill the cavity.
- Apply sealant to the face of splice sleeve on the upper half and carefully slide the upper mullion down onto the splice sleeve. Place a 1/2" temporary shim between the mullions to locate them.
- Secure the upper mullion to the mid anchors and remove the temporary shims.
- Apply and tool sealant to the face and sides of the splice sleeve to create a water tight joint.

- Leave a 1/2" expansion joint between vertical pressure plate splices and fill the joint with sealant. Ensure the hollows in the pressure plates are sealed at the splice joint.

- Locate pressure plate fasteners 1-1/2" from the end of the upper pressure plate splice and 4" from the end of the lower pressure plate splice as shown. (This will ensure the fastener will not interfere with the face cover splice sleeve.)

- Install a FC-0808 fastener on each side of the lower face cover just below where the face cover splice sleeve will be positioned.

- Apply bond breaker tape to the face of the cover splice sleeve and slide it down into the lower face cover.

- Prior to snapping on the upper portion of the face cover, apply sealant to the face of the splice.

- Leave a 1/2" expansion joint between face cover splices.

See **Details 11 & 12**.

Note: Face covers, pressure plates, and mullions are staggered at splice locations.

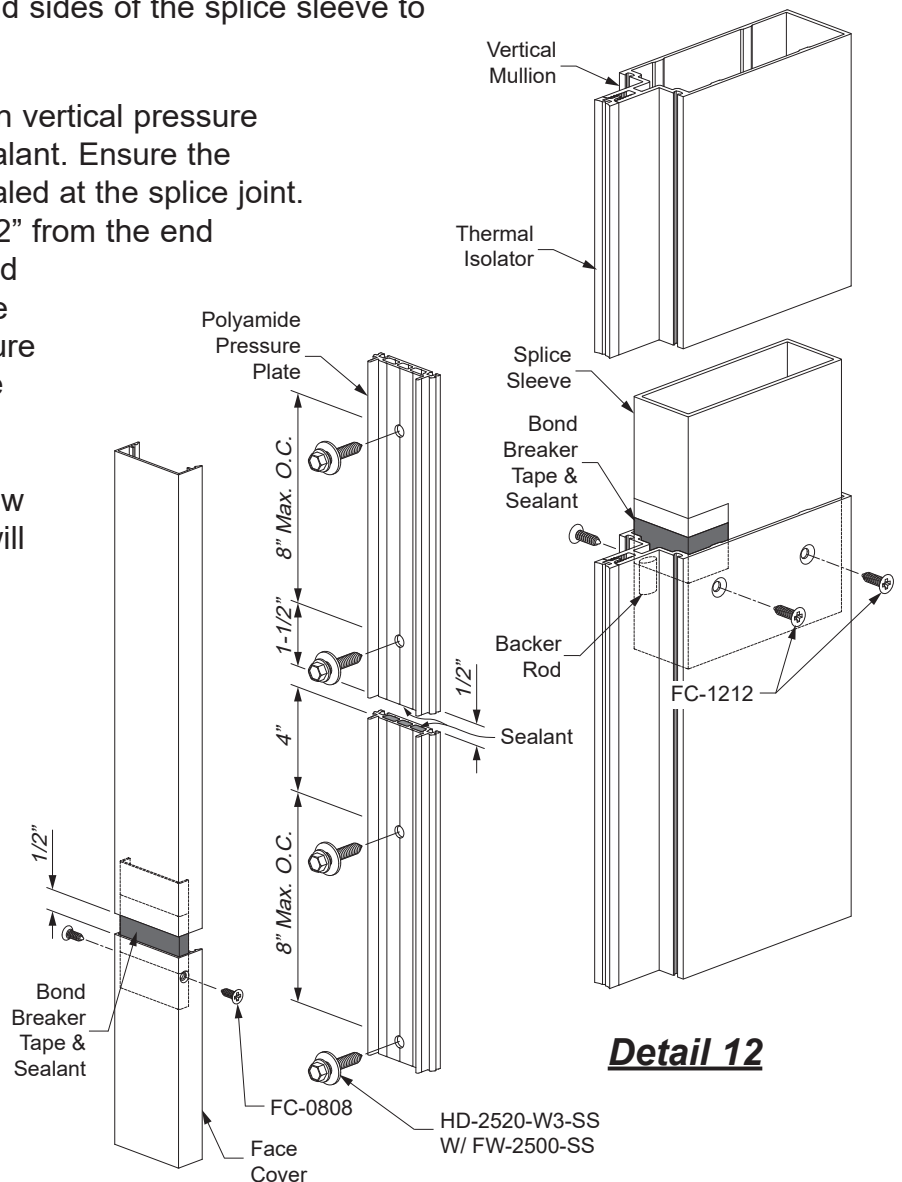

Detail 12

FRAME INSTALLATION

STEP 10 INSTALL CONTINUOUS PERIMETER ANCHOR

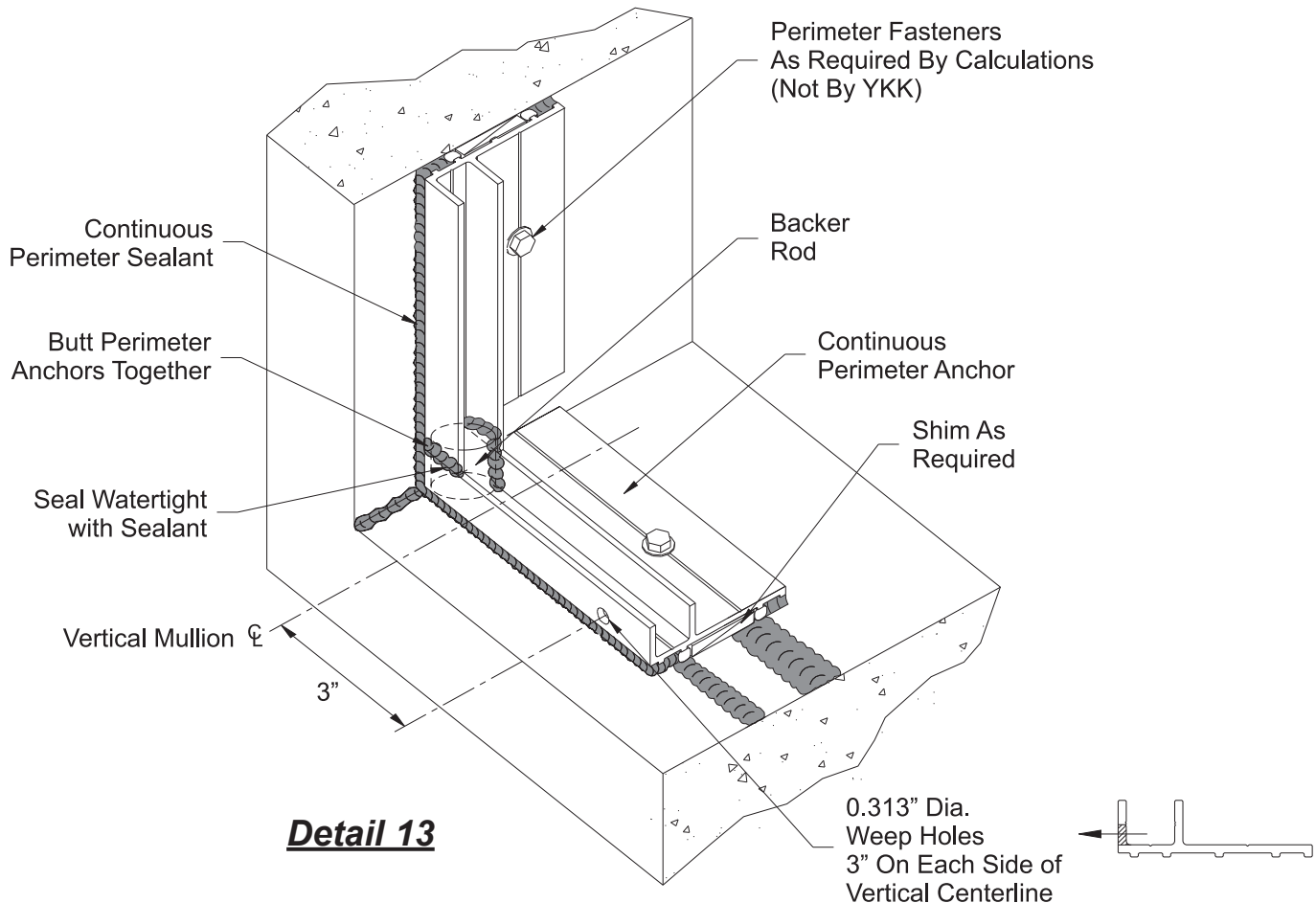

-Cut perimeter anchors to size:

Head and sill anchors stop 1/8" short of the rough opening.

Vertical jamb anchors butt in between head and sill anchors.

-Prepare structure for anchor attachment.

-Install perimeter anchors with appropriate perimeter fasteners. Refer to shop drawings or engineering calculations for type and spacing of fasteners. Shim as required to install anchors level.

-When splicing head and sill pieces together, leave 3/8" joint for expansion and install a small piece of backer rod that has been buttered with sealant on the front, back, and bottom at the joint.

-Run continuous sealant along the perimeter between the anchors and the substrate.

-Seal corners of butted perimeter anchors watertight with sealant.

-Butter a small piece of backer rod with sealant on all sides that touch the anchors. Then push the piece of backer rod into place and tool excess sealant that comes through the cracks.

-Field drill 0.313" diameter weep holes in perimeter anchor (exterior face only) at sill 3" from the center line of the vertical on each side.

See **Detail 13**.

FRAME INSTALLATION

STEP 11
JAMB/VERTICAL INSTALLATION
WITH PERIMETER ANCHORS

- The notched ends of vertical mullions for 1" glazing leaves the interior of the mullion exposed and must be plugged prior to installation.
 - Install a small piece of backer rod into the notched out space directly behind the tongue at the top and bottom of the vertical mullions.
 - Push the backer rod into the opening at the face of the mullion.
 - Apply and tool sealant to seal off the opening made by the notch.

 - Install interior gasket, E2-0120, to jamb mullion (jamb side only) the full length of the mullion.
 - Position jamb into opening as shown in **Detail 14**.
 - Seal the gap between the perimeter anchor and vertical glazing pocket(s) with sealant (one side for jambs - both sides for intermediate verticals).
 - Cut 2" long pieces of pressure plate assembly, AS-1601, and exterior glazing gasket, E2-0120, to use as temporary retainers.
 - Install them at the top and bottom of the mullion with HM-2520-W3-SS fasteners.
 - Repeat this step for all jamb and vertical mullions.
- See **Detail 14**.

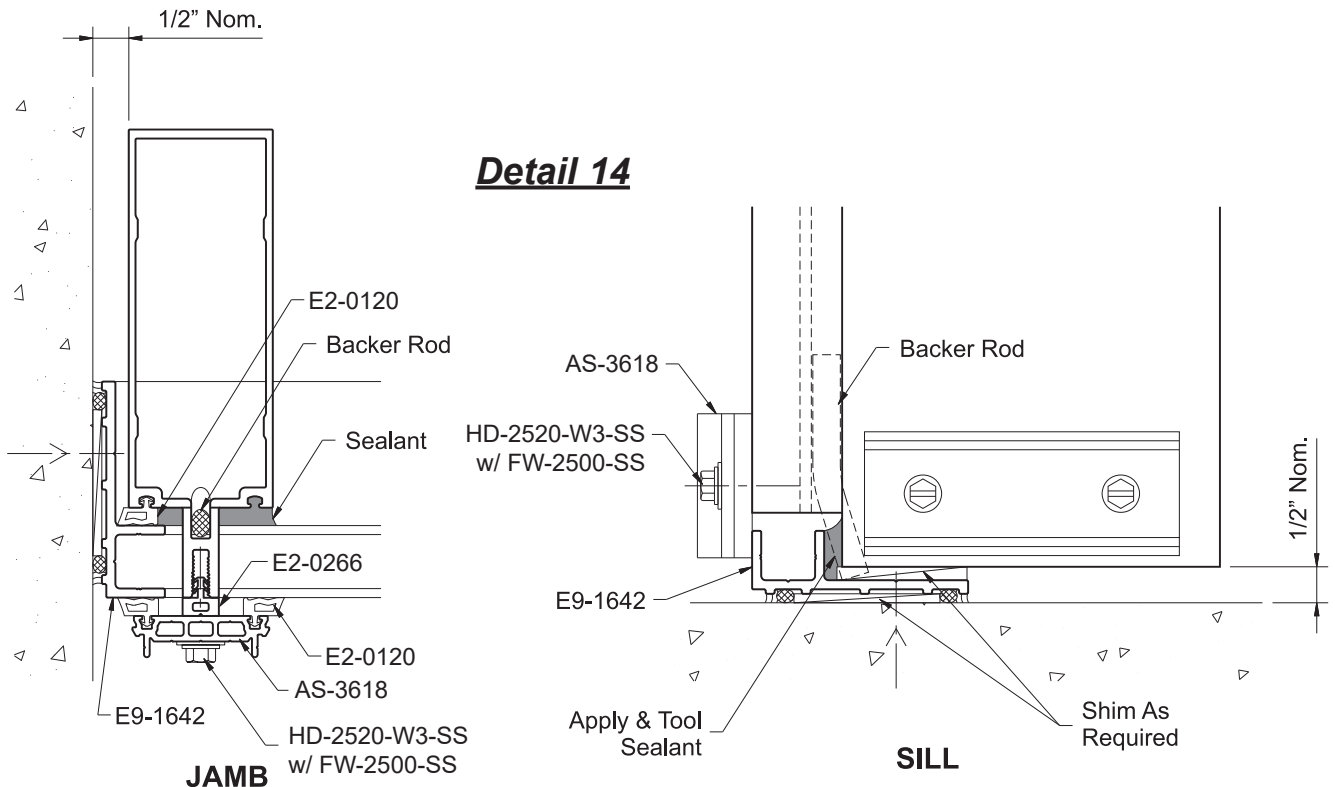

FRAME INSTALLATION

**STEP 12
JAMB/VERTICAL INSTALLATION
WITH MULLION END ANCHORS**

- Clean all contact surfaces as recommended by sealant manufacturer.
 - Apply sealant into the screw raceway and along the front edge of the mullion at each end.
 - Prior to erecting mullions, install mullion end caps, E1-1290, at the top and bottom of the mullions with FC-1410 fasteners.
 - Seal all screw heads with sealant.
- See **Detail 15**.

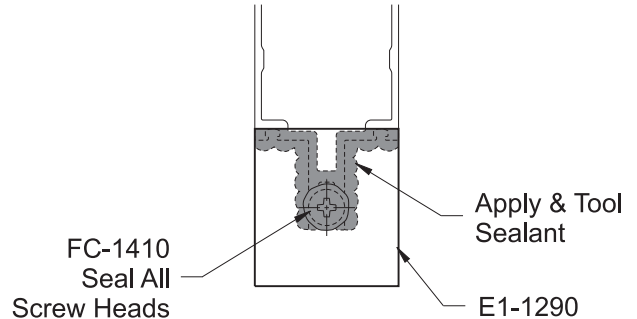

Detail 15

- Insert mullion “T” and “F” anchors into the top and bottom of the mullions before erecting them into the opening.
 - Erect and locate the jamb and mullions and temporarily attach them to the structure. All mullions must be installed plumb and true.
 - Field drill holes in “T” and “F” anchors for the appropriate anchor fasteners according to shop drawings or engineering calculations. Consult YKK if load requirements are in question.
- See **Detail 16**.

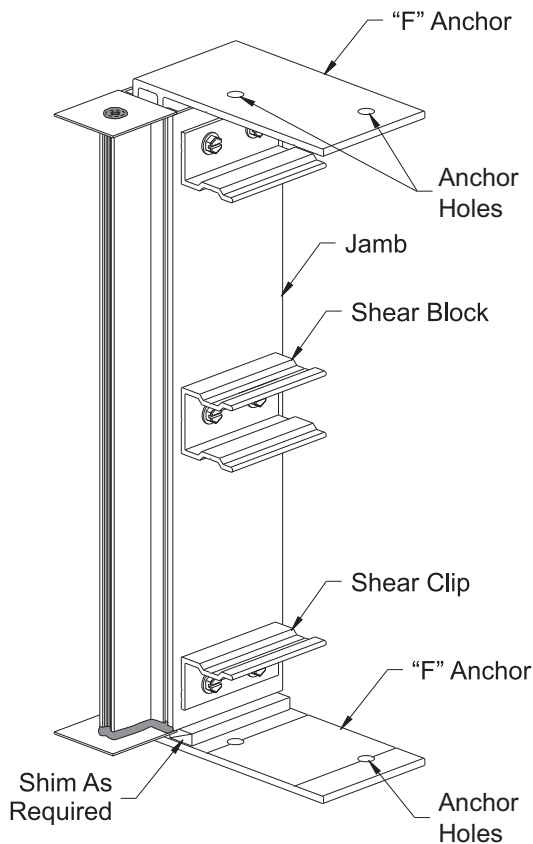

Detail 16

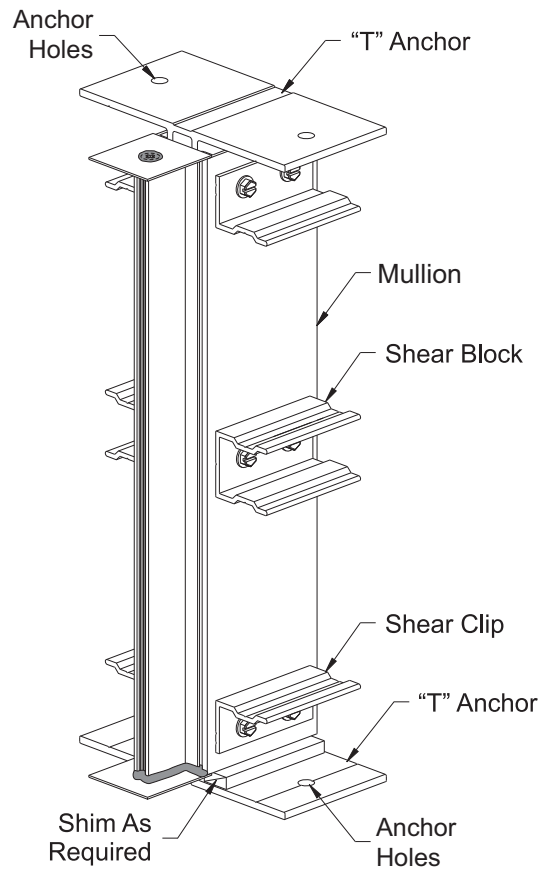

FRAME INSTALLATION

STEP 12A VERTICAL INSTALLATION AT DOOR JAMB END ANCHORS

The mullions at the door jambs are set directly upon the sill substrate without any shims and are sealed against the substrate. The anchors to be used at this location are specified by the approved shop drawings and or P.E. calculations.

-Locate the mullion anchor for the door jamb and install it to the substrate according to the approved shop drawings and P.E. calculations.

Note: if using a shear block as a mullion anchor, check to ensure the sill shear block fasteners will not cause interference. Field modify the shear block anchor as required.

See **Detail 18**.

-Clean all contact surfaces as recommended by sealant manufacturer.

-Set the mullion on the anchor, directly onto the sill substrate in a bed of sealant. Do not use shims at this location.

See **Detail 17**.

-Refer to the approved shop drawings for any additional fasteners required.

-Tool sealant at the bottom of the mullion at the sill substrate around the perimeter of the mullion.

See **Detail 19**.

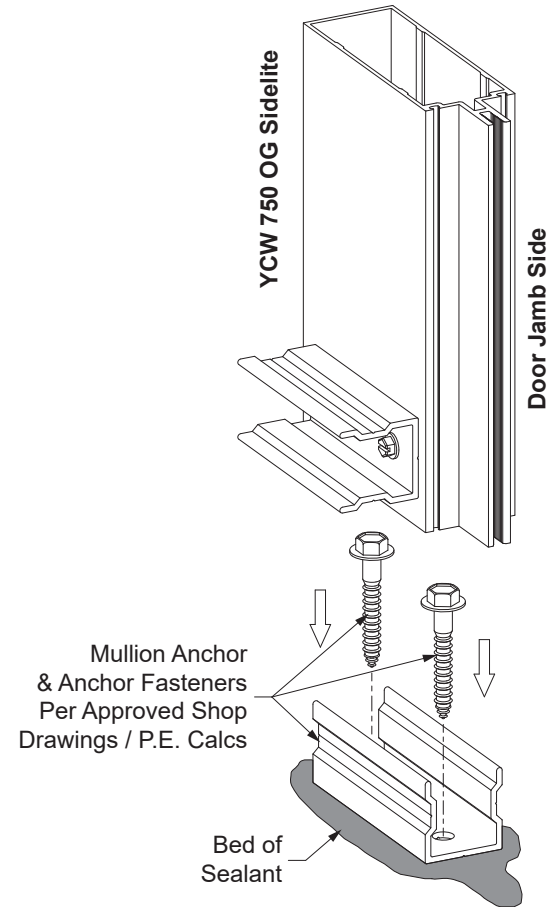

Detail 17

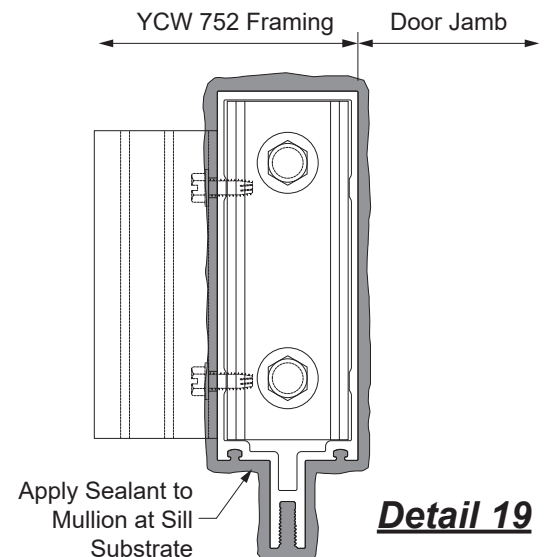
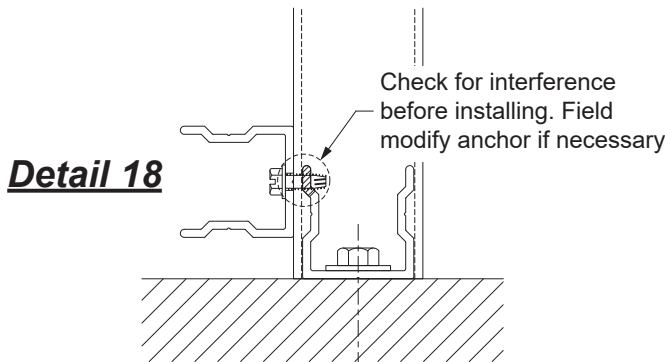

FRAME INSTALLATION

**STEP 13
INSTALL WIND LOAD / DEAD LOAD ANCHORS**

-Install steel wind load and dead load anchor clips. Anchor clips are normally template or line set before mullions are hung. Outstanding leg of clip must be set at 90° to offset line.
The back of the vertical mullion should set 1" from the anchoring substrate.
See **Detail 20**.

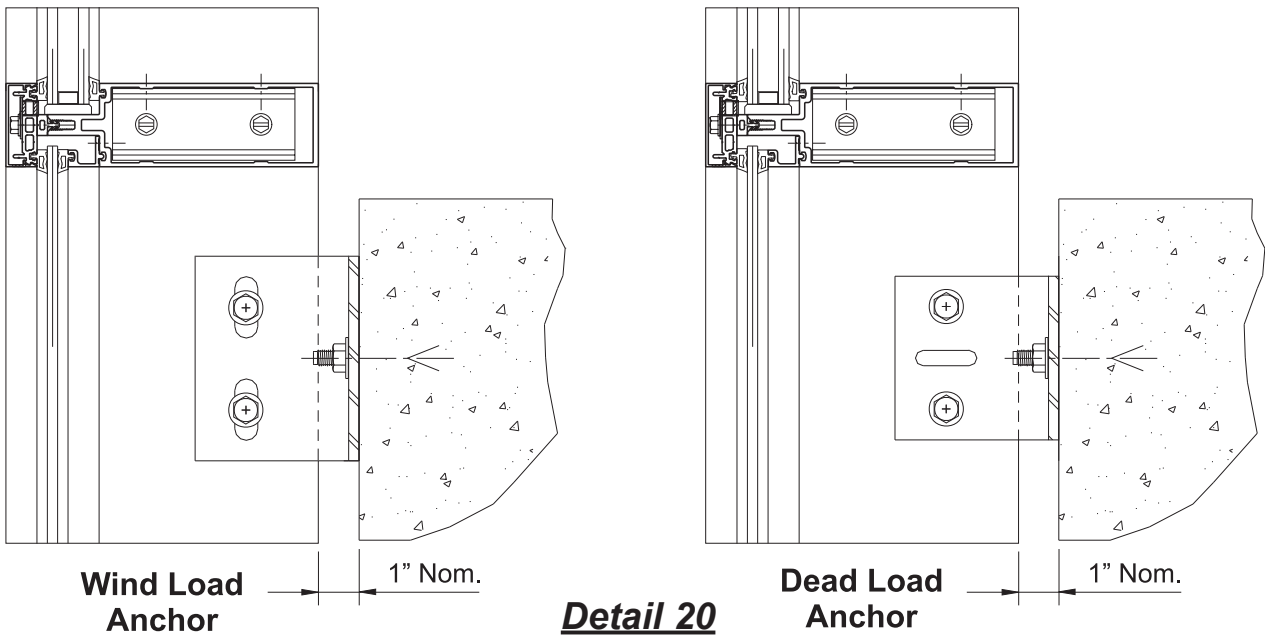

-Install, plumb, and align vertical mullions. Drill and install appropriate diameter anchor bolts. If shop drawings are not prepared by YKK AP, all anchors and bolts must be checked by a qualified engineer.

-Nylon slip pads, E3-0103, must be installed between mullion and anchor.
See **Detail 21**.

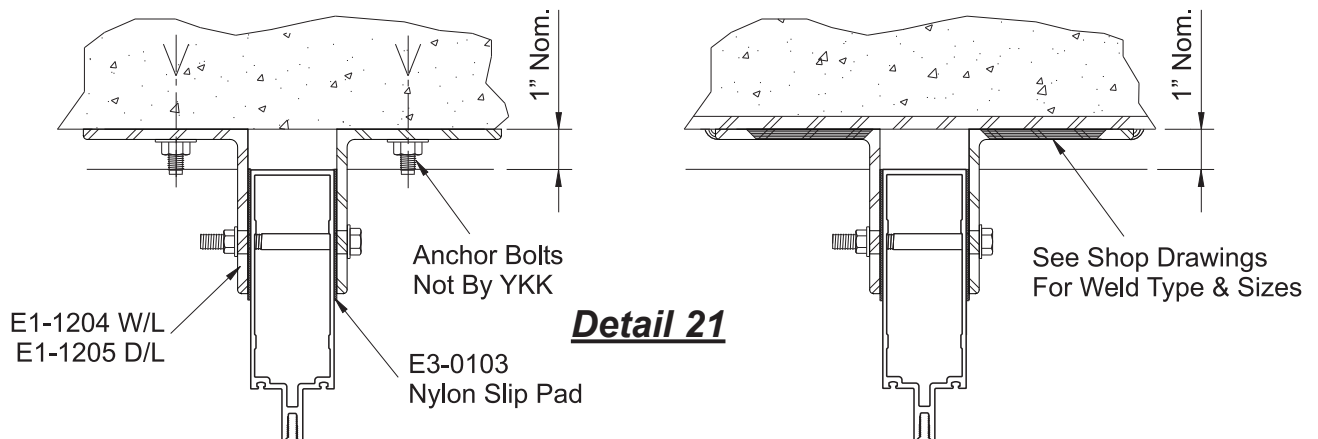

FRAME INSTALLATION

TYPICAL WIND LOAD ANCHOR

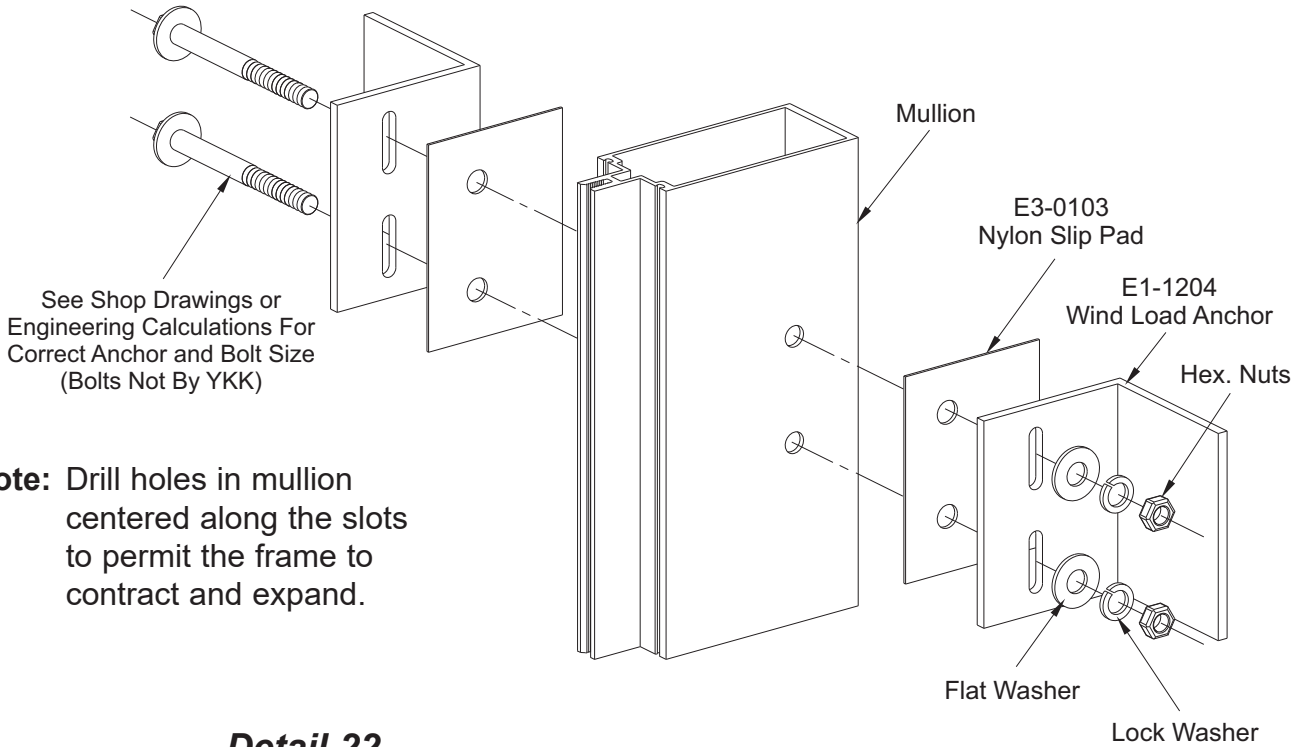

Note: Drill holes in mullion centered along the slots to permit the frame to contract and expand.

Detail 22

TYPICAL DEAD LOAD ANCHOR

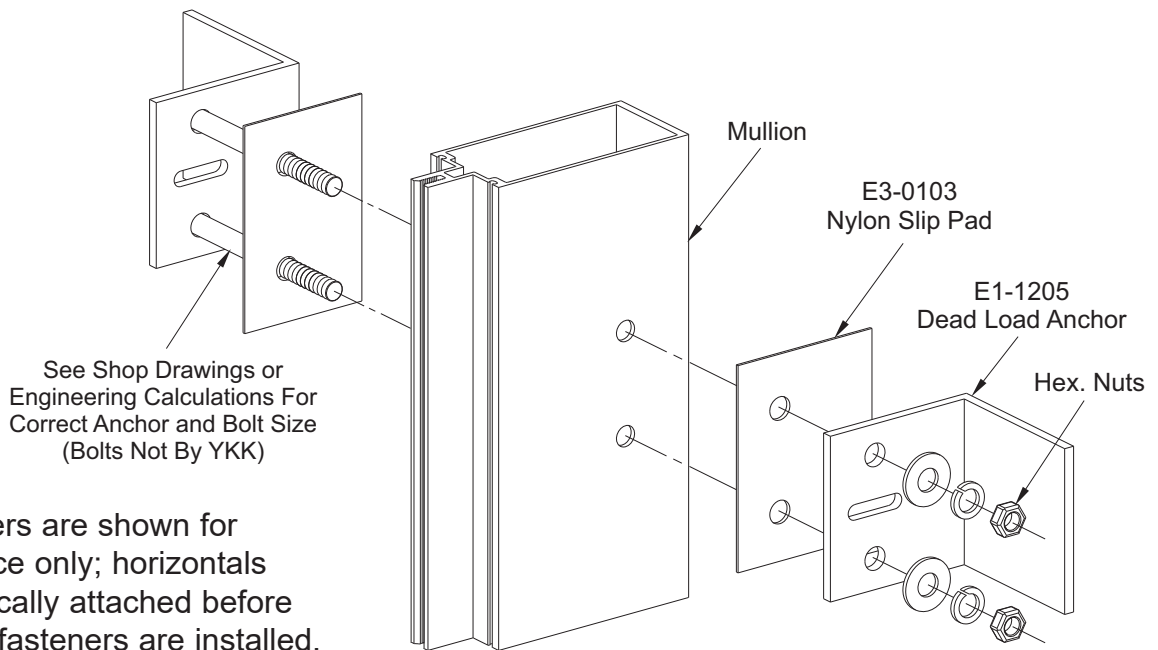

Note: Fasteners are shown for reference only; horizontals are typically attached before anchor fasteners are installed.

FRAME INSTALLATION

JAMB WIND LOAD ANCHOR

Note: Drill holes in mullion centered along the slots to permit the frame to contract and expand.

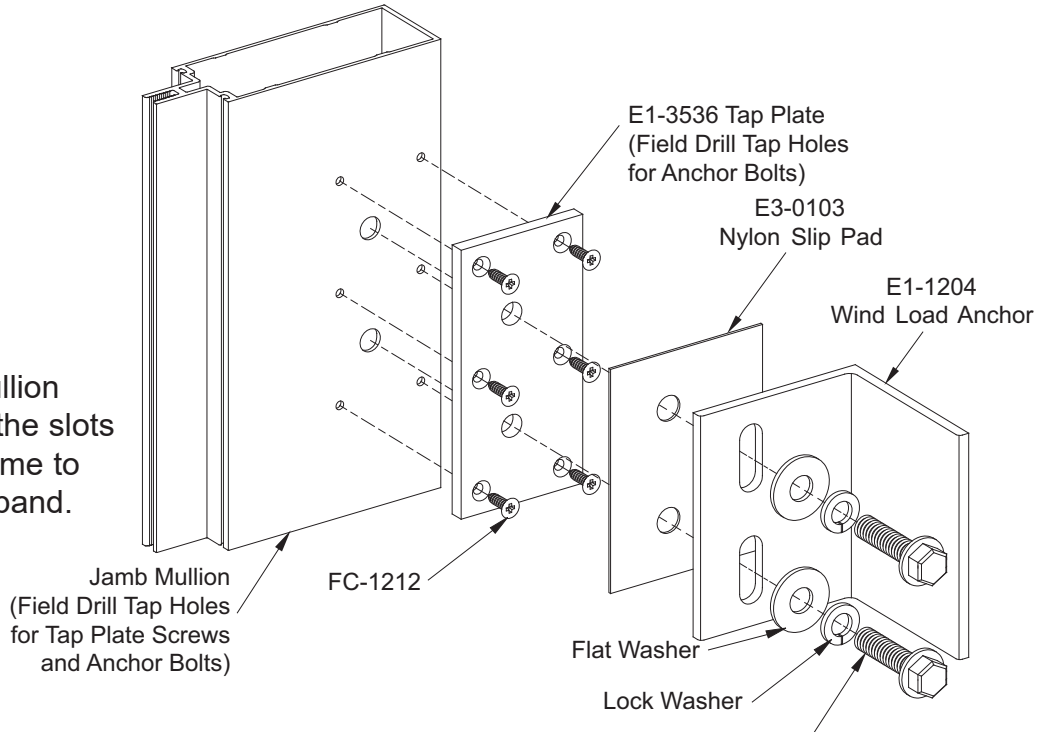

See Shop Drawings or Engineering Calculations For Correct Anchor and Bolt Size (Bolts Not By YKK)

Detail 22A

JAMB DEAD LOAD ANCHOR

Note: Fasteners are shown for reference only; horizontals are typically attached before anchor fasteners are installed.

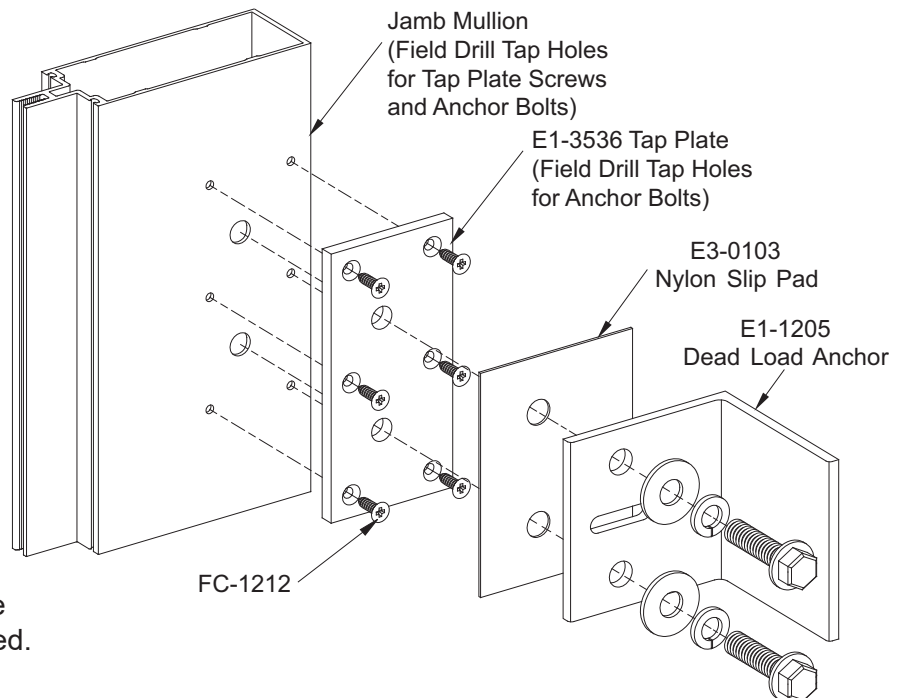

FRAME INSTALLATION

STEP 14

ATTACH HORIZONTAL MEMBERS

- Slide the horizontal members towards the mullions making sure that the glazing pockets line up and transfer the hole locations on top of the horizontal to the shear block.
- Remove the horizontal and drill a 0.189" dia. (#12 bit) hole at each hole location.

-Just prior to attaching the horizontal members to the mullion, apply sealant to the front of the shear block as shown below.

Note: Before applying any sealant, clean aluminum surfaces using cleaner and method approved by sealant manufacturer.

- Slide the horizontal back against the mullion and attach it to the shear block with two FC-1212 fasteners at each end.
- Tool and wipe away any excess sealant at the vertical to horizontal joints.

See **Detail 23**.

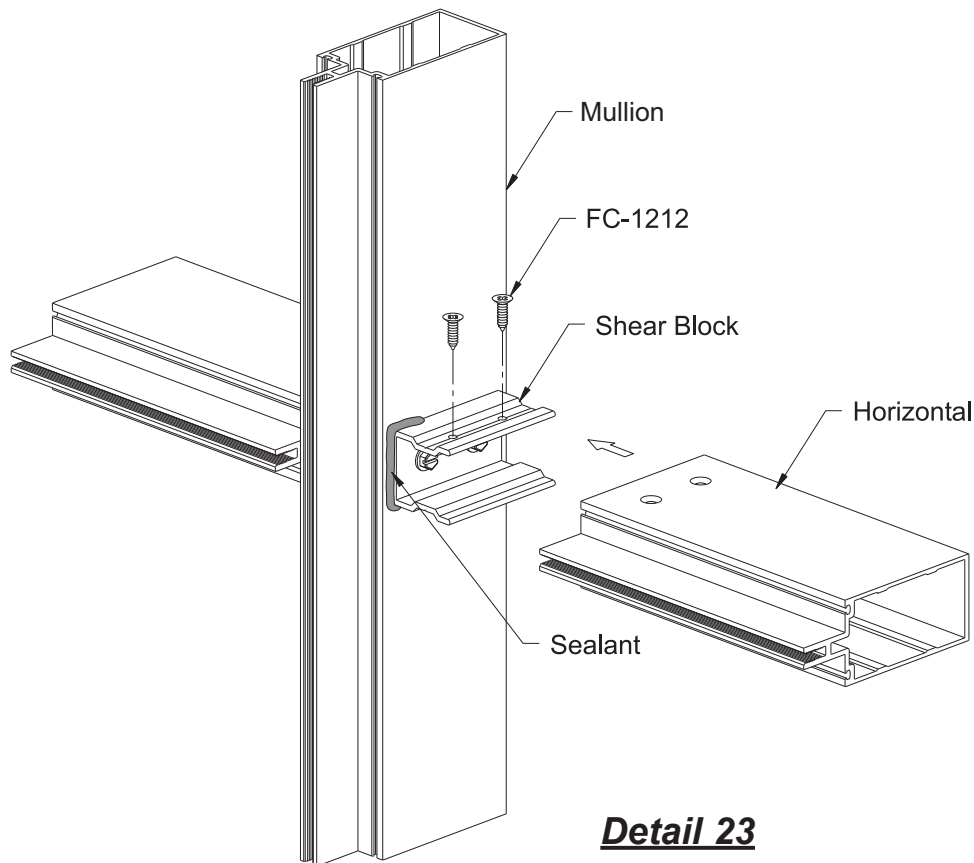

Detail 23

FRAME INSTALLATION**STEP 14 (Continued)
ATTACH HORIZONTAL MEMBERS****If Optional Concealed Fastener Shear Blocks Are Used:**

Attachment of horizontals is similar to that of exposed fasteners, except the horizontals are fastened at the front of the shear blocks with (2) FC-1220 fasteners per shear block.

See **Detail 24**.

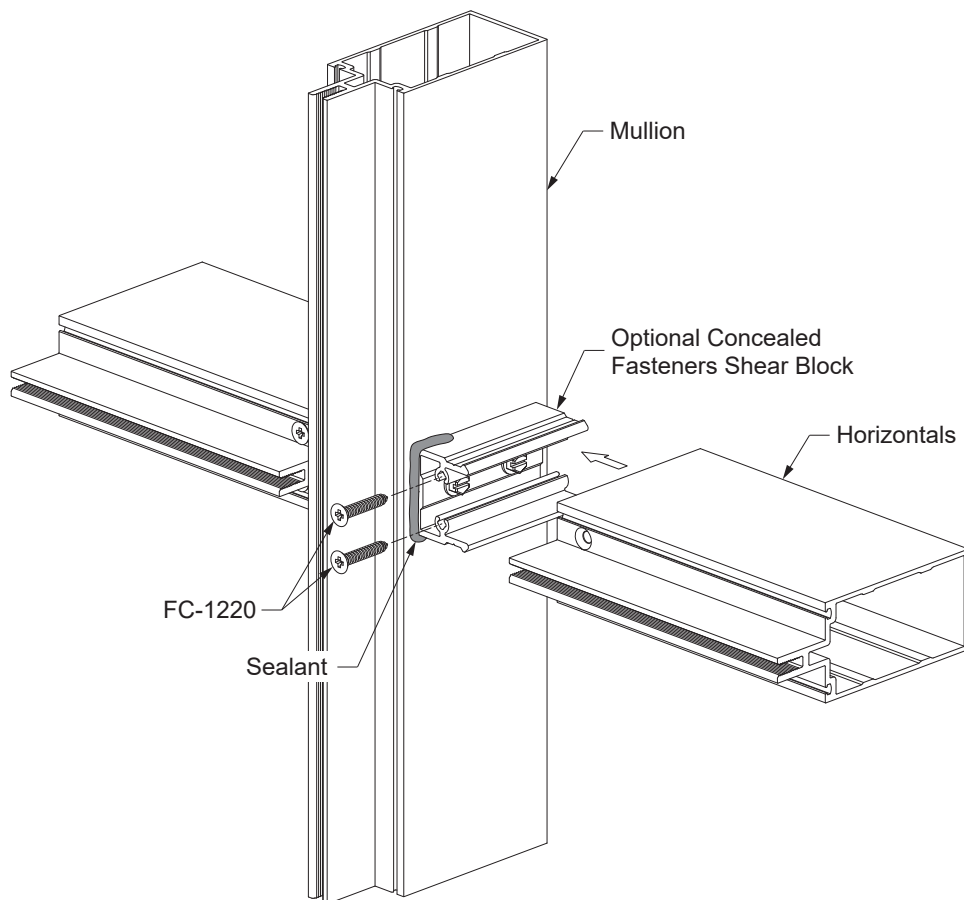

Detail 24

FRAME INSTALLATION

STEP 14 (Continued) ATTACH HORIZONTAL MEMBERS

At Head and Sills:

- Mullion end anchors must be installed before head and sill members are attached.
 - Provide anchor fasteners as per job requirements. See approved shop drawings or engineering calculations for appropriate anchor fasteners.
 - Install the anchor fasteners as recommended by fastener manufacturer.
- Attach head and sill members to the shear clip according to the procedures previously shown in **Detail 23** with the notched out portion facing the anchors.

See **Detail 25**.

Caution: There must always be a shim under the mullion to transfer glazing dead loads to the foundation.

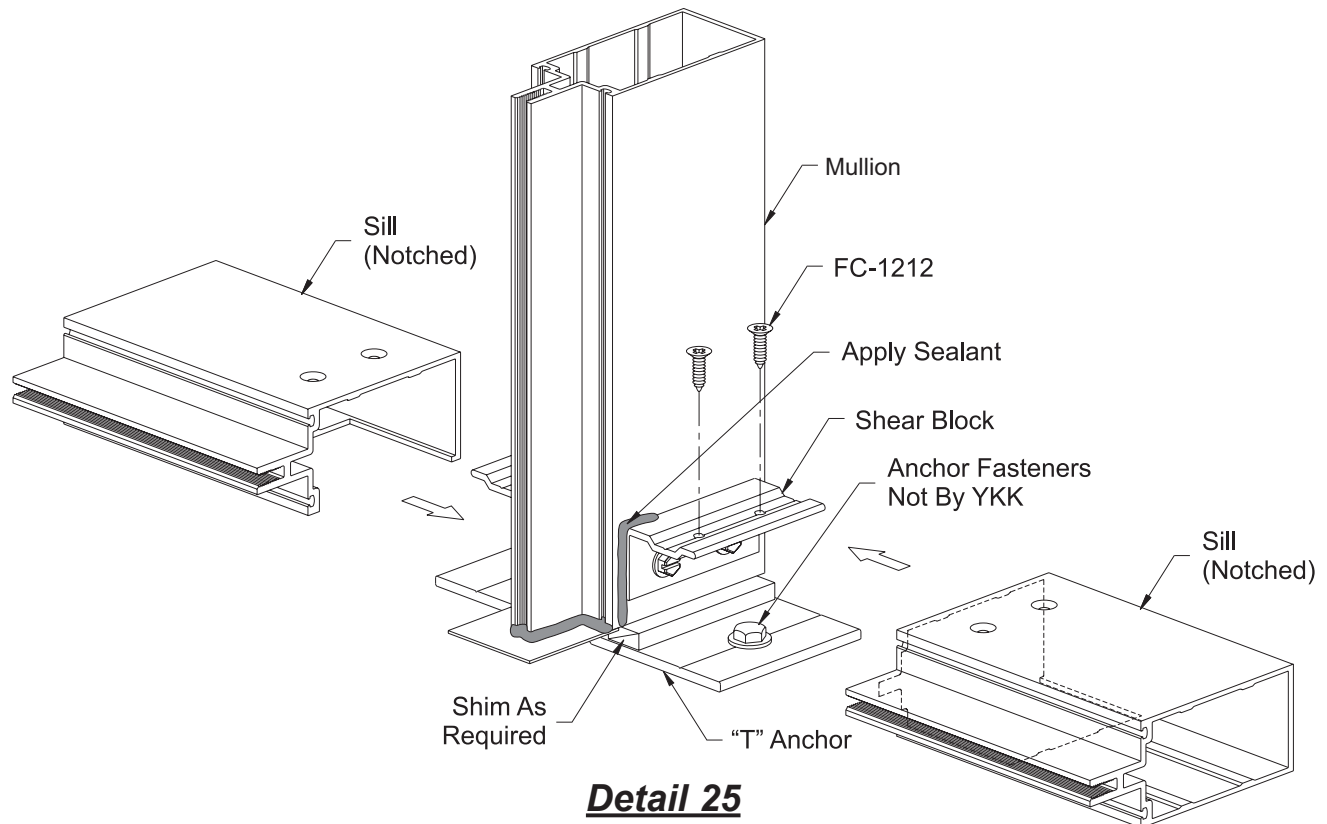

Detail 25

FRAME INSTALLATION

**STEP 14 (Continued)
ATTACH HORIZONTAL MEMBERS**

For One Piece Horizontals at End Bays:

- Slide the horizontal into place from the interior; the shear blocks should easily pass through the E-Slots at the ends of the horizontal.
- Make sure that the glazing pockets are flush.
- Attach the horizontal to the shear block/clip at each end with (2) FC-1212 fasteners as previously instructed.

See **Detail 26**.

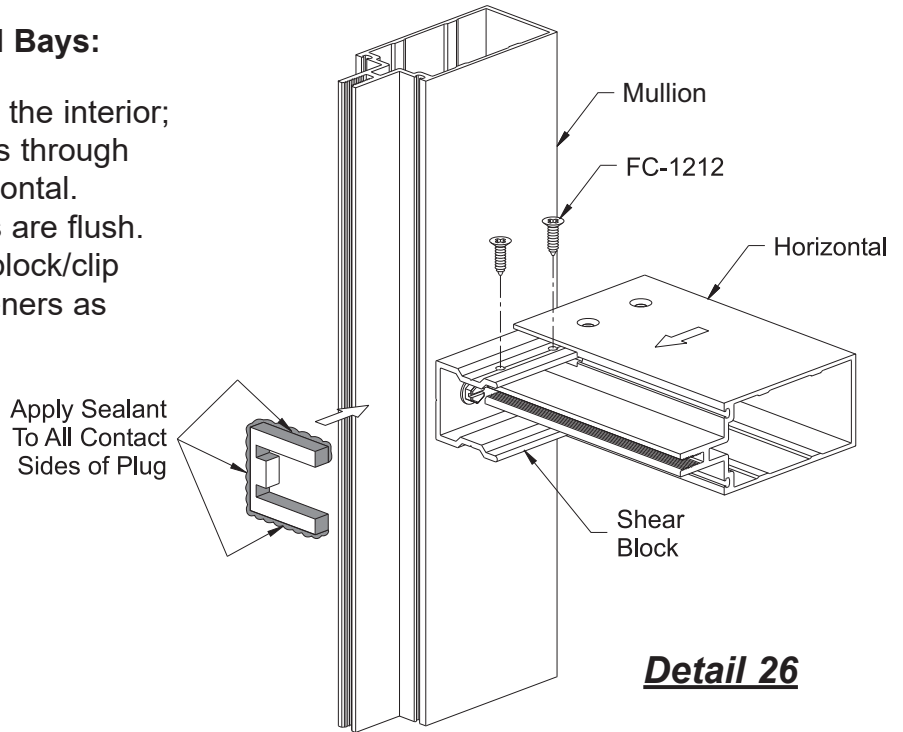

Detail 26

- Apply sealant to all contact sides of the E-Slot plug, E2-0146.
- Insert the E-Slot plugs into place and press them firmly against the shear blocks.
- Cover the entire slot with sealant and tool the sealant to ensure a watertight seal.

See **Detail 27**.

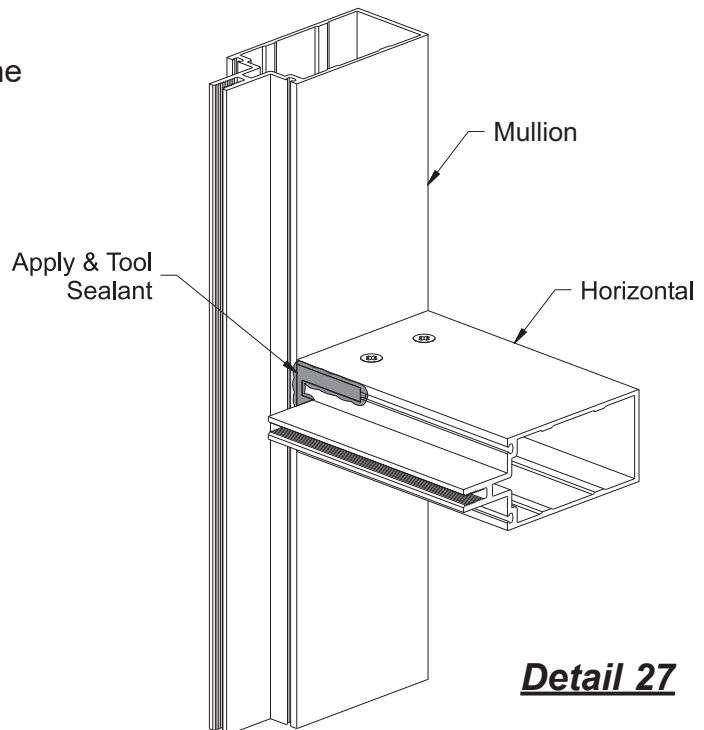

Detail 27

FRAME INSTALLATION

STEP 15 INSTALL DOOR SUBFRAMES

Refer to the **Entrances Installation Manual** for assembly of the door subframes. These subframes are typically glazed into the curtain wall framing at the jambs, and set directly upon the sill substrate without any shims. The subframe members are determined by the approved shop drawings.

-Clean all sealant contact surfaces as recommended by the sealant manufacturer.

-Install the jamb subframe onto the mullion with fasteners according to the approved shop drawings and/or P.E. calculations, setting the subframe jambs in beds of sealant as shown in **Detail 28**.

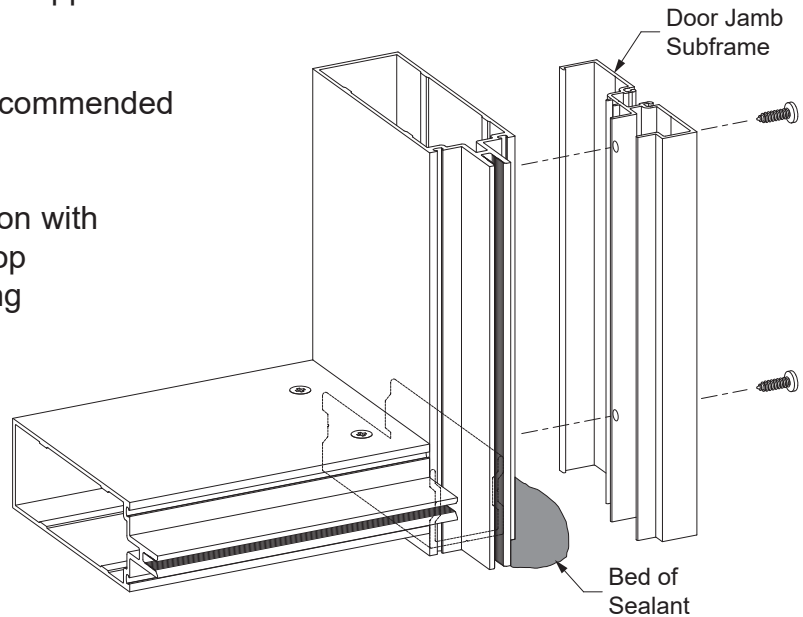

Detail 28

-Apply and tool sealant to the bottom of the jamb subframe as shown in **Detail 29**.

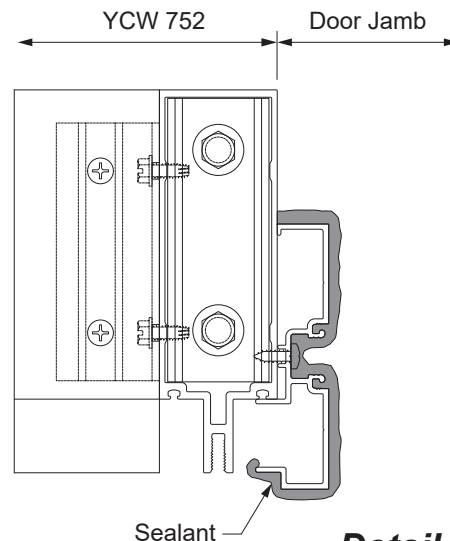

Detail 29

FRAME INSTALLATION

**STEP 15
APPLY PERIMETER SEALANT**

- Clean the area around the perimeter of the frame with cleaner and method approved by sealant manufacturer.
- Push in backer rod between the perimeter of the frame and the substrate about 1/4".
- Apply sealant to the perimeter of the frame.
- Tool the sealant making sure that sealant does not get into the gasket reglets.

See **Detail 30**.

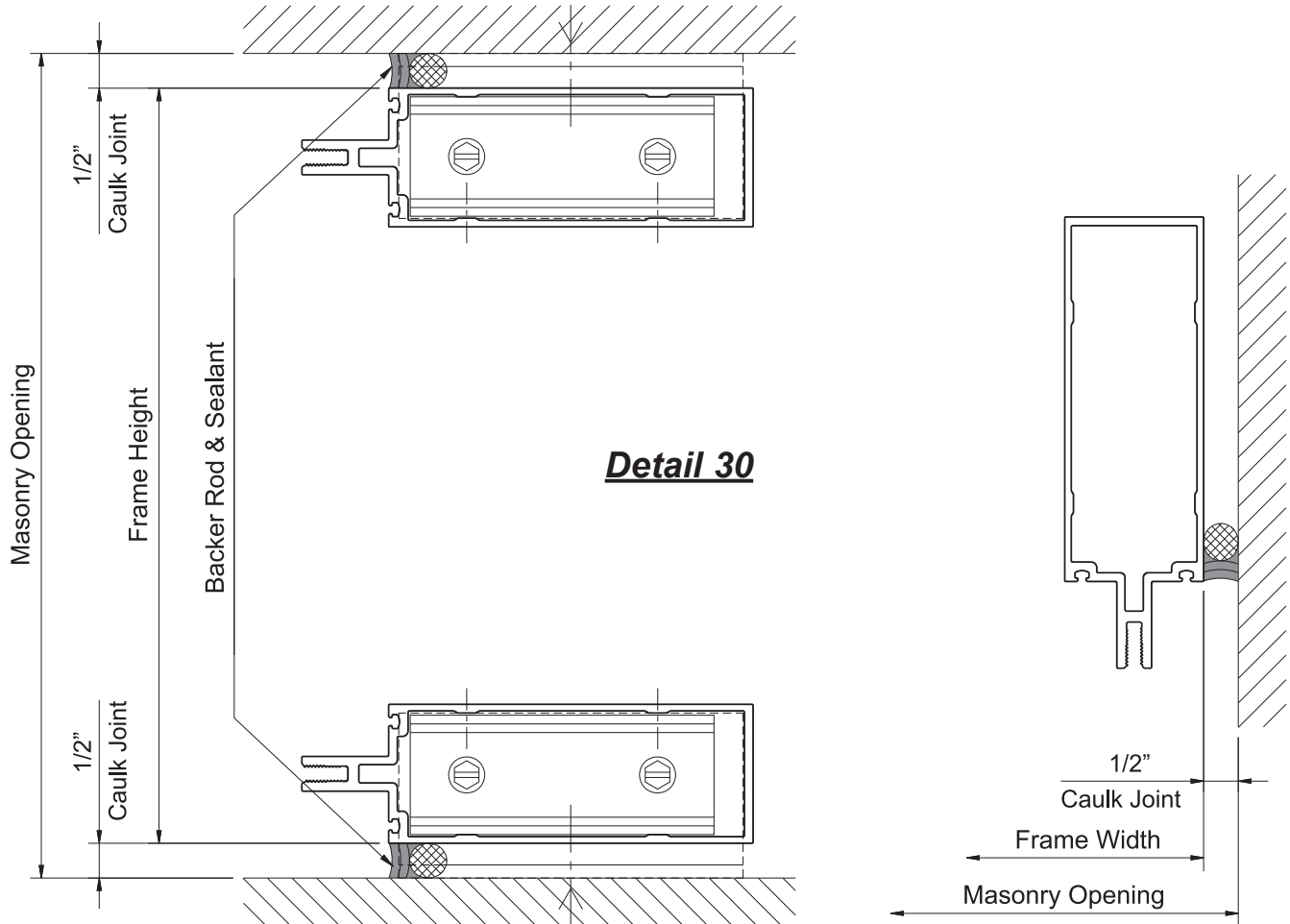

FRAME INSTALLATION

STEP 16
INSTALL THERMAL ISOLATOR

-Install the E2-0266 thermal isolator cut to the full length of the mullion.

See **Detail 31**.

THERMAL ISOLATOR
VERTICAL INSTALLATION

Detail 31

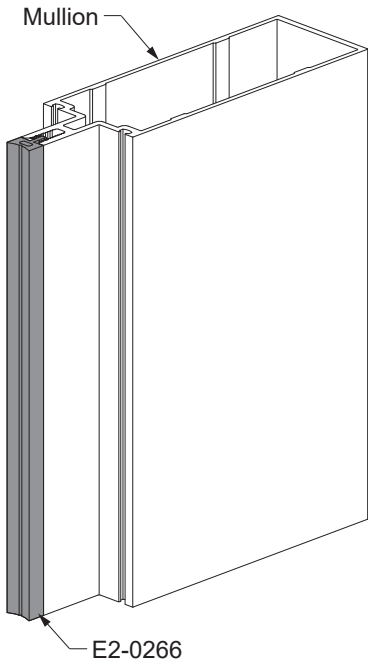

THERMAL ISOLATOR
HORIZONTAL INSTALLATION

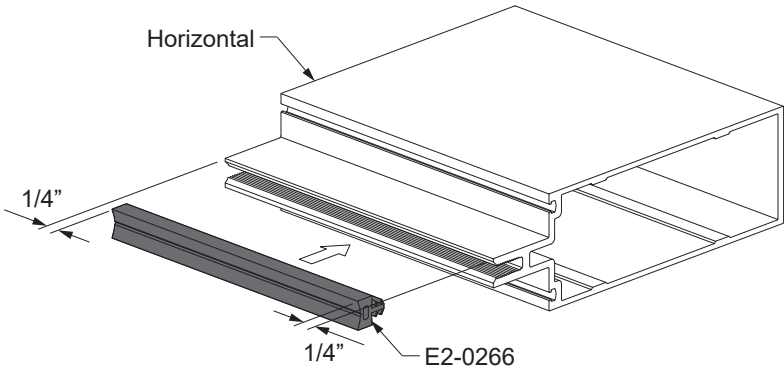

Detail 32

-Cut the thermal isolator to D.L.O. minus(-) 1/2" and center.
-Install the thermal isolator into the horizontals, leaving 1/4" at each end for sealant at joint plugs.
See **Detail 32**.

Note:
-Thermal isolators can be applied in the shop prior to assembly and erection.

FRAME INSTALLATION

**STEP 17
INSTALL JOINT PLUGS**

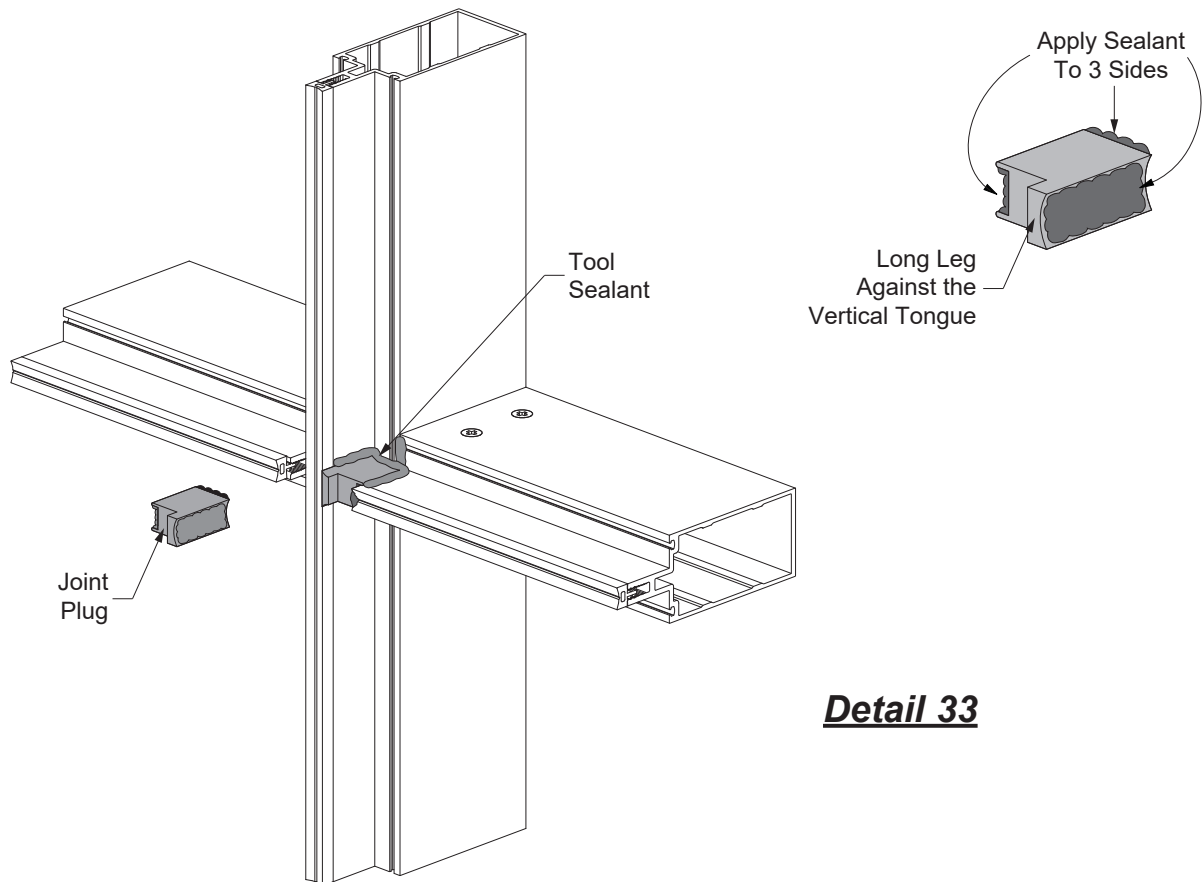

Detail 33

The tongue of each horizontal must be sealed to the tongue of the mullions. The space between the two tongues is closed by using joint plugs, E2-0138 for 1" glazing or E2-0285 for 1/4" glazing.

- Clean the area around the tongue intersection with an approved cleaner.
- Apply and tool sealant to the intersection of the horizontal and vertical.
- Apply sealant to the three contact sides of the joint plug and at the intersection of the mullion and horizontal glazing pocket.
- Install joint plug as shown with the long leg of plug against the vertical tongue.
- Press joint plugs firmly against face of mullion.
- Tool the sealant to ensure a watertight seal.

See **Detail 33**.

GLAZING

STEP 18 INSTALL GLAZING ADAPTORS (When Required)

- Cut glazing adaptors, E9-1604, to size:
 Vertical Cut Length = Daylight Opening plus(+) 1".
 Horizontal Cut Length = Daylight Opening minus(-) 1/32".
- Predrill each adaptor with 0.189" dia. (#12) holes 2" from each end.
- Dry fit adaptors and match drill 0.141" dia. (#28) holes on mullion to receive PC-0806 screws.
- Clean the area around the mullion glazing reglet and the glazing adaptor with a cleaner approved by the sealant manufacturer.
- Apply sealant into the mullion gasket reglets and the ends of the horizontal adaptors.
- Install the adaptors with PC-0806 screws 2" from each end and at the center of the adaptor.
- Install the vertical adaptors first and make sure they are centered along the day light opening.
- Tool sealant at all adaptor intersections and seal all screw heads.

See **Detail 34**.

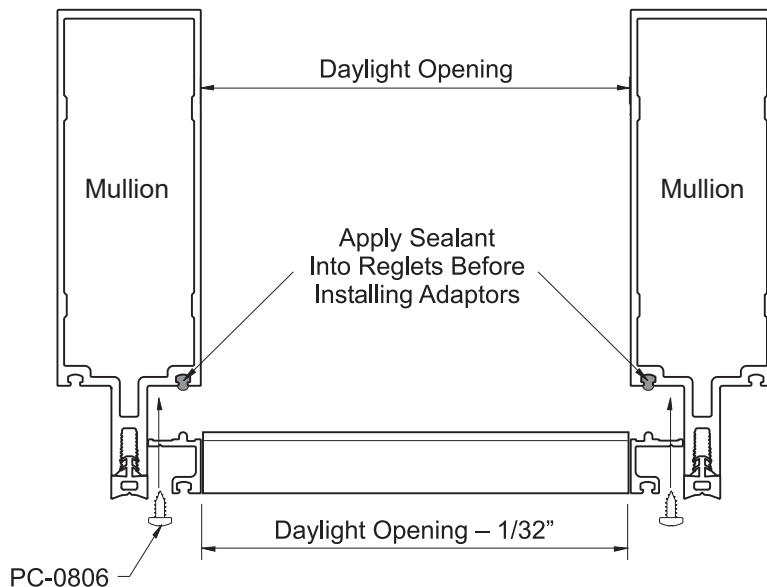
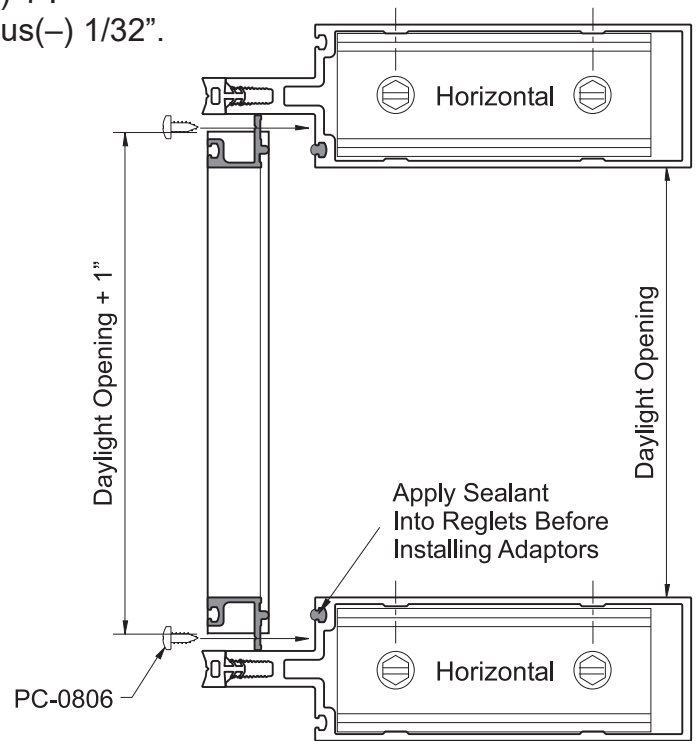

Detail 34

GLAZING

STEP 19 INSTALL INTERIOR GLAZING GASKETS

-Cut interior glazing gaskets to size:

Vertical Gasket = Daylight Opening + 1-1/4".

Horizontal Gasket = Daylight Opening + 3/16" per each foot of opening width.

-Install vertical gaskets first, centered along the daylight opening.

-Install horizontal glazing spacers next.

-Insert the glazing spacer into the reglet at each end first.

-Snap the rest of the glazing spacer into the reglet starting at the center and work towards each end.

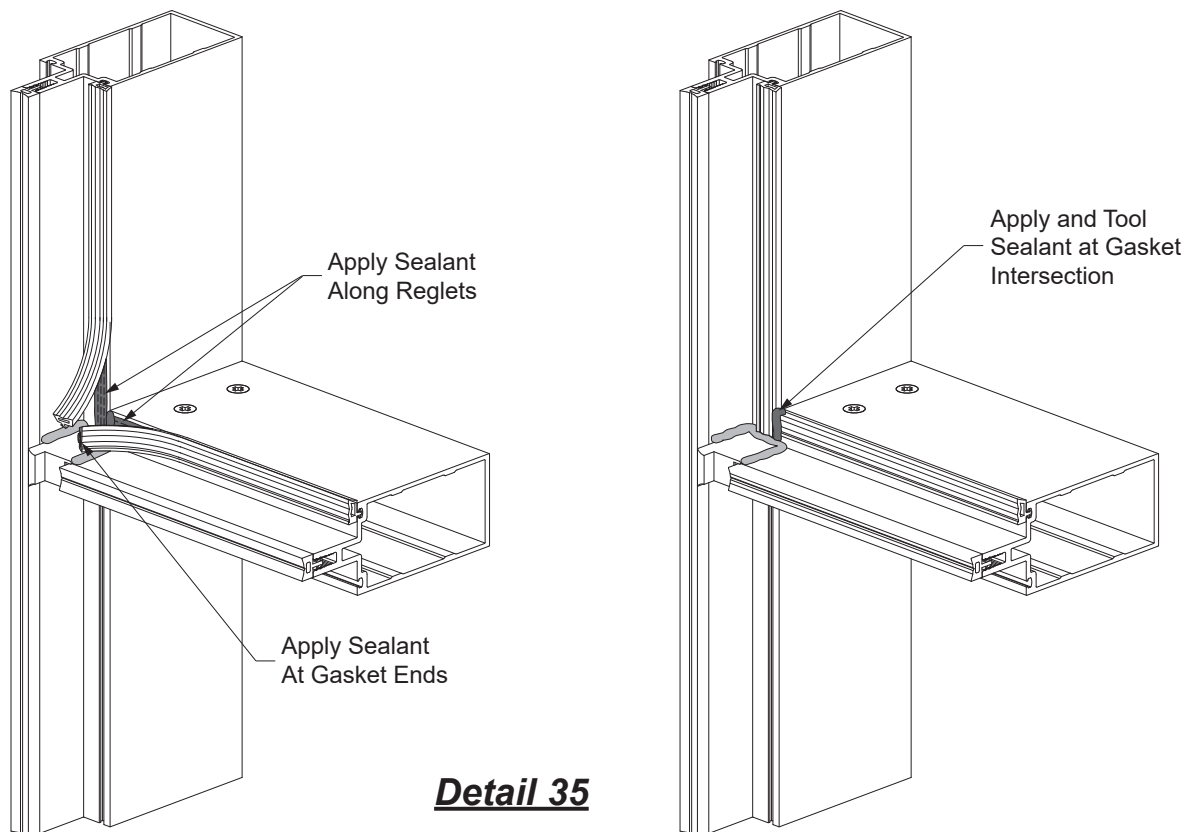

-Pull the last 3" of each gasket away from the reglet.

-With gasket end held out of the way, run a 2-3" bead of sealant into the reglet at the ends.

-Apply sealant at the ends of the horizontal gaskets.

-Reinsert the ends of the gaskets pressing them firmly against the face of the mullions.

-Apply and tool sealant at the intersection of the vertical and horizontal gaskets.

See **Detail 35**.

GLAZING

STEP 20
INSTALL SETTING & SIDE BLOCKS

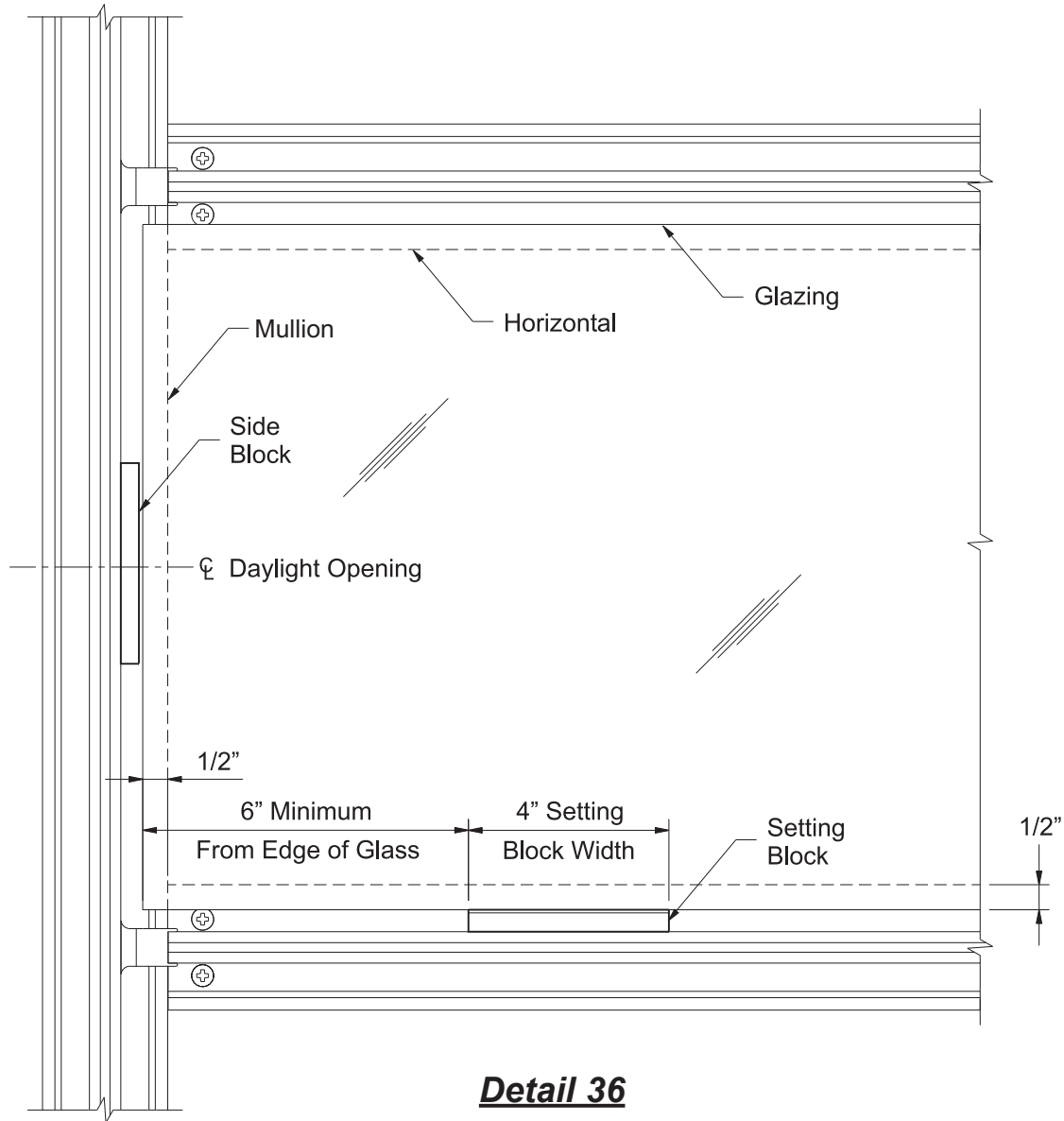

Detail 36

- Install setting blocks, E2-0134 for 1" glazing or E2-0623 for 1/4" glazing, at 1/4 points of D.L.O. or minimum of 6" from edge of glass, whichever is greater. Consult YKK AP for setting block requirements on units that exceed 60" x 90" or 40 sq. ft.
- Install side blocks, E2-0133 for 1" glazing centered along the daylight opening on both sides of glazing material.

See **Detail 36**.

GLAZING

STEP 21 INSTALL PERIMETER PVC FILLERS

- For polyamide pressure plate application, the PVC perimeter filler (E3-3665) must be installed in all perimeter conditions before the pressure plates are installed.
- Apply a thin strip of silicone sealant into the reglet on the jamb million.

Note: Too much silicone will prevent the engagement of the perimeter filler.

- Center and snap the perimeter filler and tap into place.

See **Detail 37**.

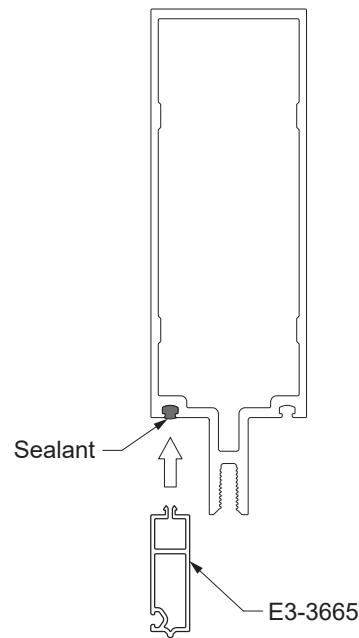

Detail 37

STEP 22 INSTALL EXTERIOR GLAZING GASKETS

- Preload exterior vertical glazing gaskets to the same length as the vertical pressure plates.
- Preload exterior horizontal glazing gaskets to daylight opening plus 1/4" per foot of opening width.
- Install vertical glazing gaskets onto the vertical pressure plates.
- Install horizontal gaskets by pushing each end into the reglet of the pressure plate. Next press center of gasket into reglet; then push gasket into reglet working from center towards the ends.

Caution: Do not stretch the gaskets.

GLAZING

STEP 23
INSTALL GLASS

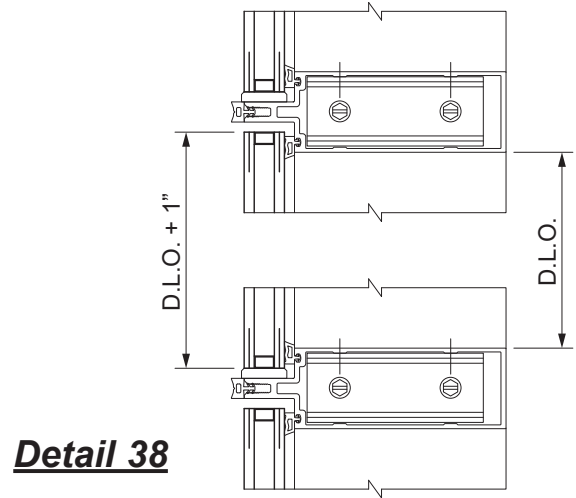
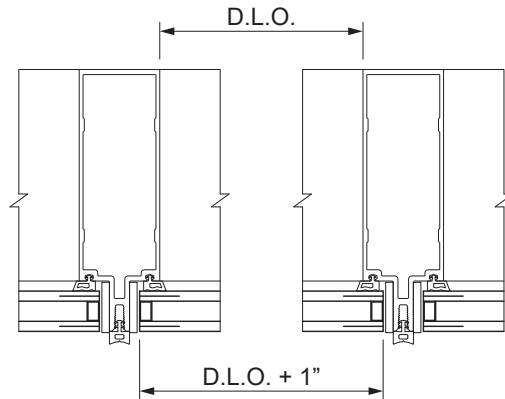

Detail 38

- As each lite is installed, attach a temporary retaining clip, E1-3012, in the middle of each horizontal and 4" from glass edge at each end using HD-2516-W3-SS fasteners.
- Reuse the temporary retaining clips.
- Apply sealant to the face of the joint plugs just prior to installing vertical pressure plates.

Caution: Do not allow sealant to skin over prior to installing pressure plates.

Note: Sealant must form a complete seal between the exterior gasket, pressure plate, thermal isolator, and the joint plug.

See **Details 38 & 39.**

Glass and Spandrel Size = Daylight Opening + 1" horizontally and vertically.

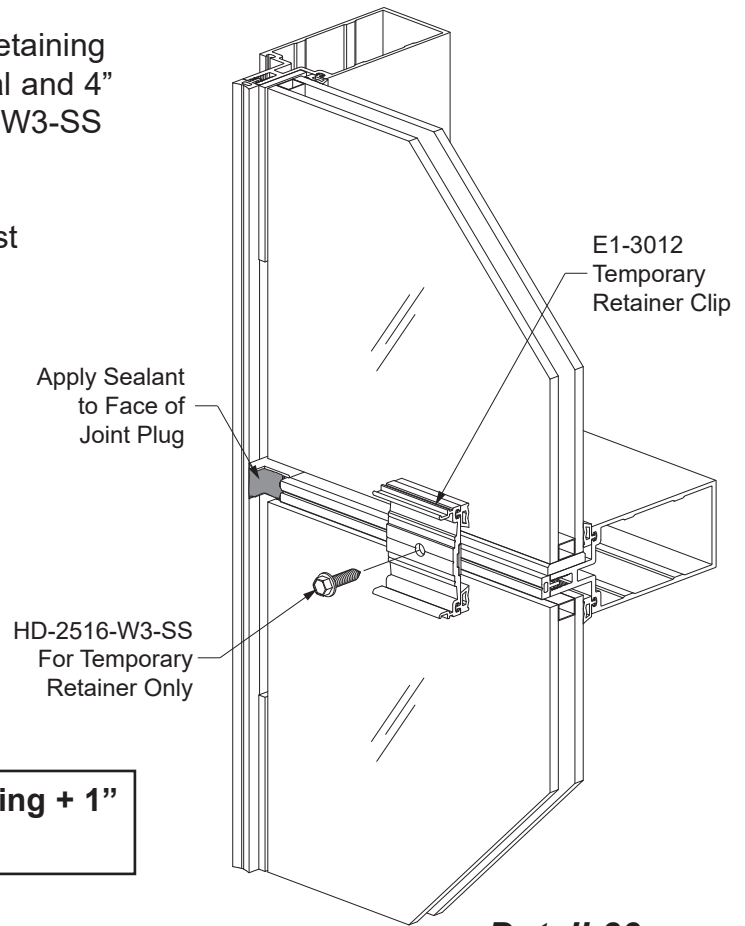

Detail 39

GLAZING

STEP 24

INSTALL VERTICAL PRESSURE PLATES AND VERTICAL FACE COVERS

-Pressure plate stock lengths are drilled with 0.281" diameter holes at 8" O.C. maximum. After cutting, additional holes may be required to have screws 1-1/2" from each end. See **Detail 42** on **Page 41**.

-Working from the bottom up, install vertical pressure plates using HD-2520-W3-SS screws and FW-2500-SS fender washers. Initially torque screws to 30 inch-pounds with a speed wrench or torque limiting screw gun.

-Torque all vertical pressure plate screws to 40 to 45 inch-pounds.

-Snap on exterior vertical face covers using a mallet and a clean scrap piece of lumber. Start at one end and work down the mullion. Avoid hitting the center of the cover. See **Detail 40**.

-Fasten the cover to the pressure plate with one PF-0808-SS screw at the bottom of each vertical cover. See **Detail 41**.

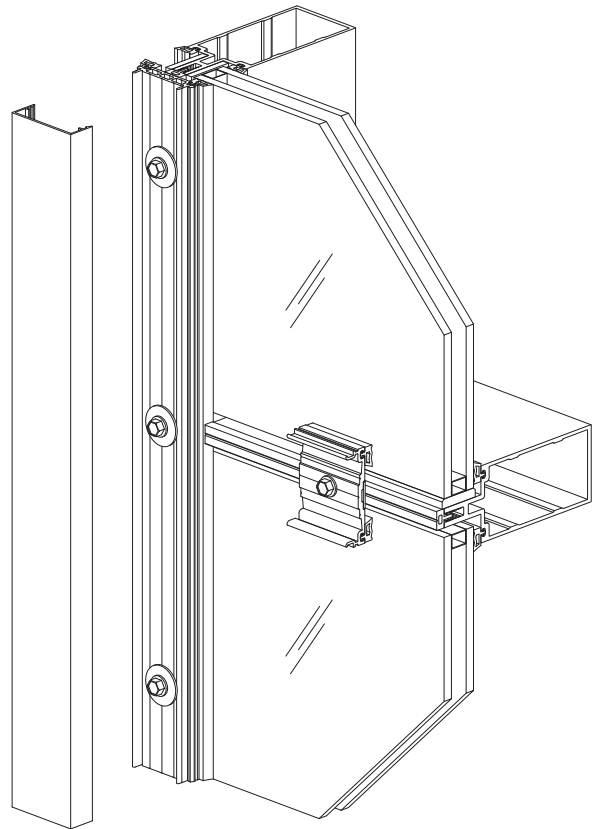

Detail 40

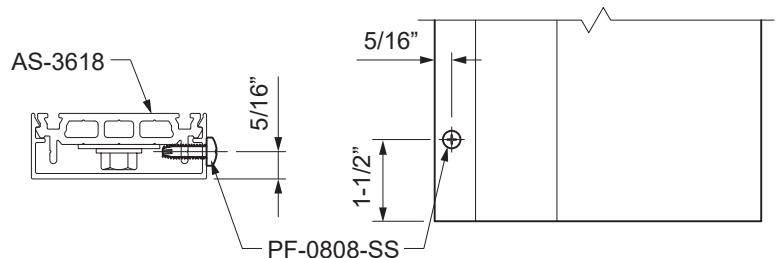

Detail 41

GLAZING

STEP 25
PRESSURE PLATE LAYOUT AND ASSEMBLY

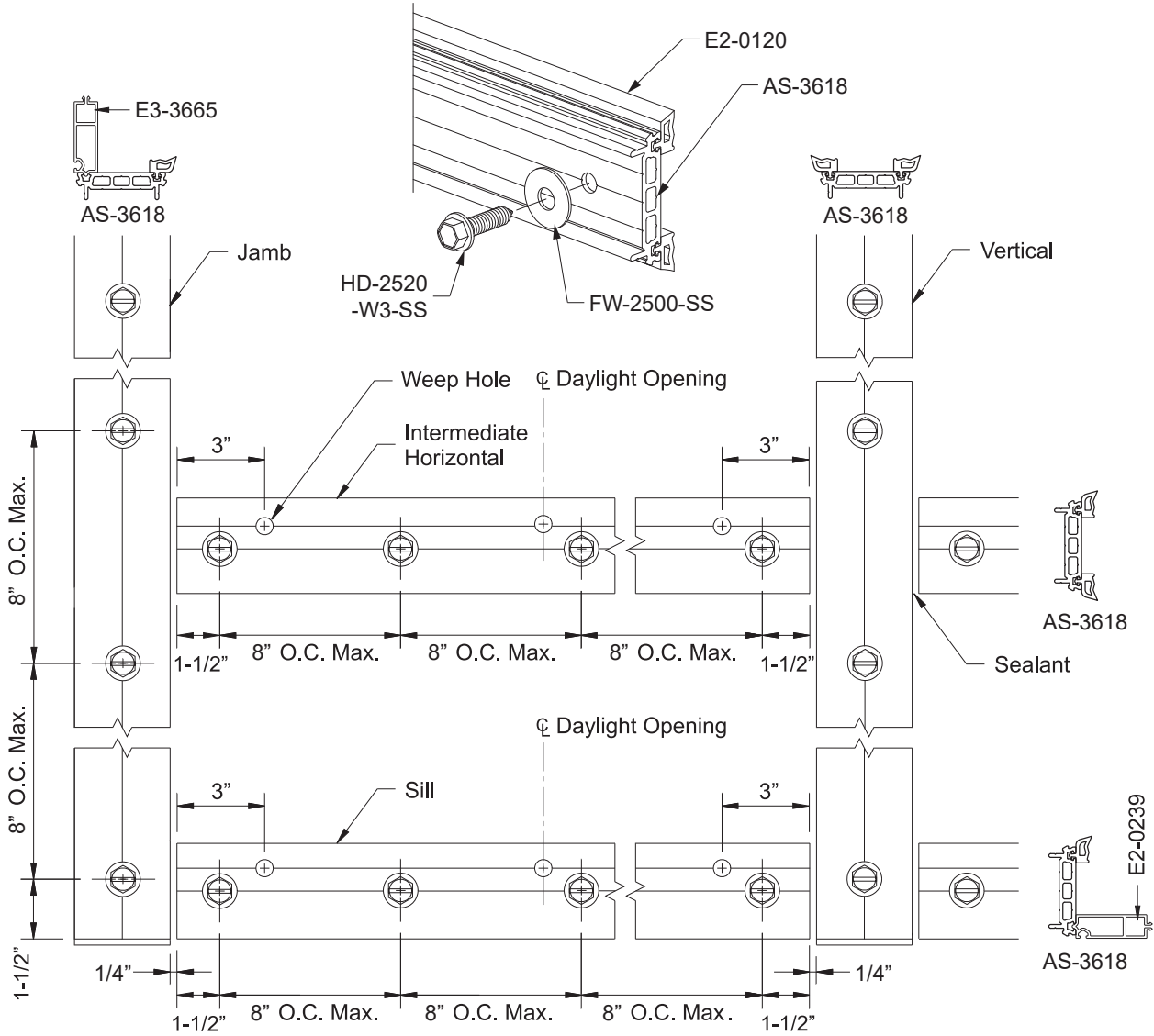

Detail 42

- Center and install horizontal pressure plates in opening, leaving a 1/4" gap at the ends.
- Starting at the center of each pressure plate, tighten each retainer screw to 40 inch-pounds.

See **Detail 42** for pressure plate layout.

GLAZING

**STEP 26
INSTALL EXTERIOR HORIZONTAL FACE COVERS**

- Apply and tool sealant between each end of the horizontal pressure plates and the vertical face cover.
 - Snap on exterior horizontal face covers.
- See **Detail 43**.

Note: Attachment of horizontal face covers with a depth greater than 1-3/4" should be reviewed by a Professional Engineer.

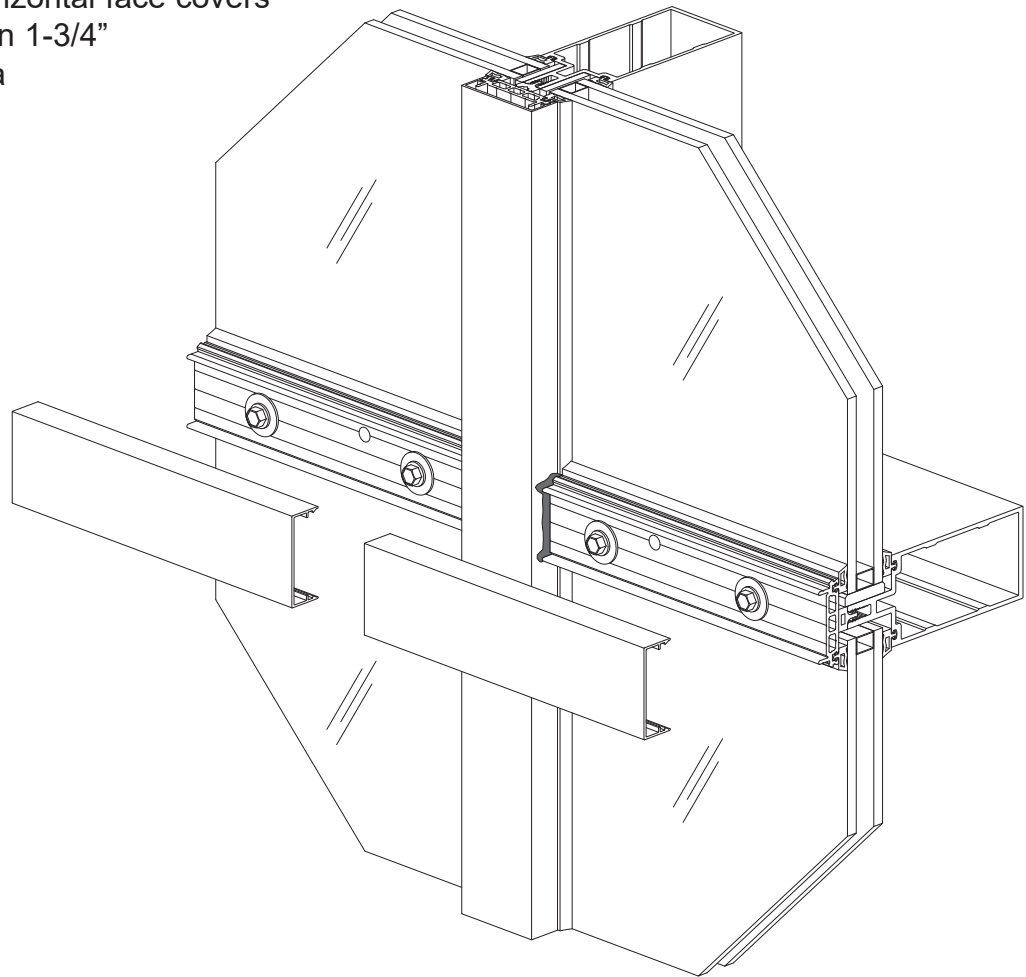

Detail 43

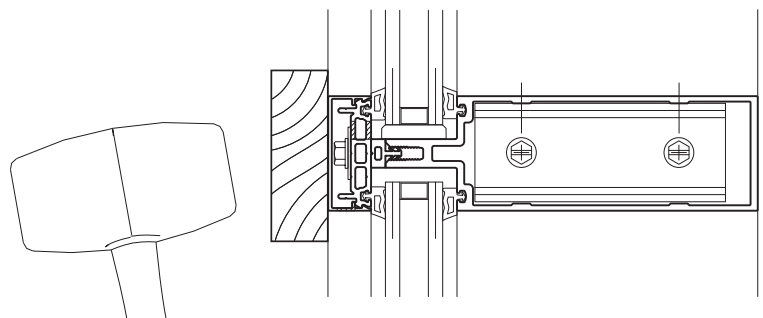



101 Marietta Street NW
Suite 2100
Atlanta, Georgia 30303
www.ykkap.com