

**YCW 750 XT IG Inside Glazed Curtain Wall System
SSG Option**

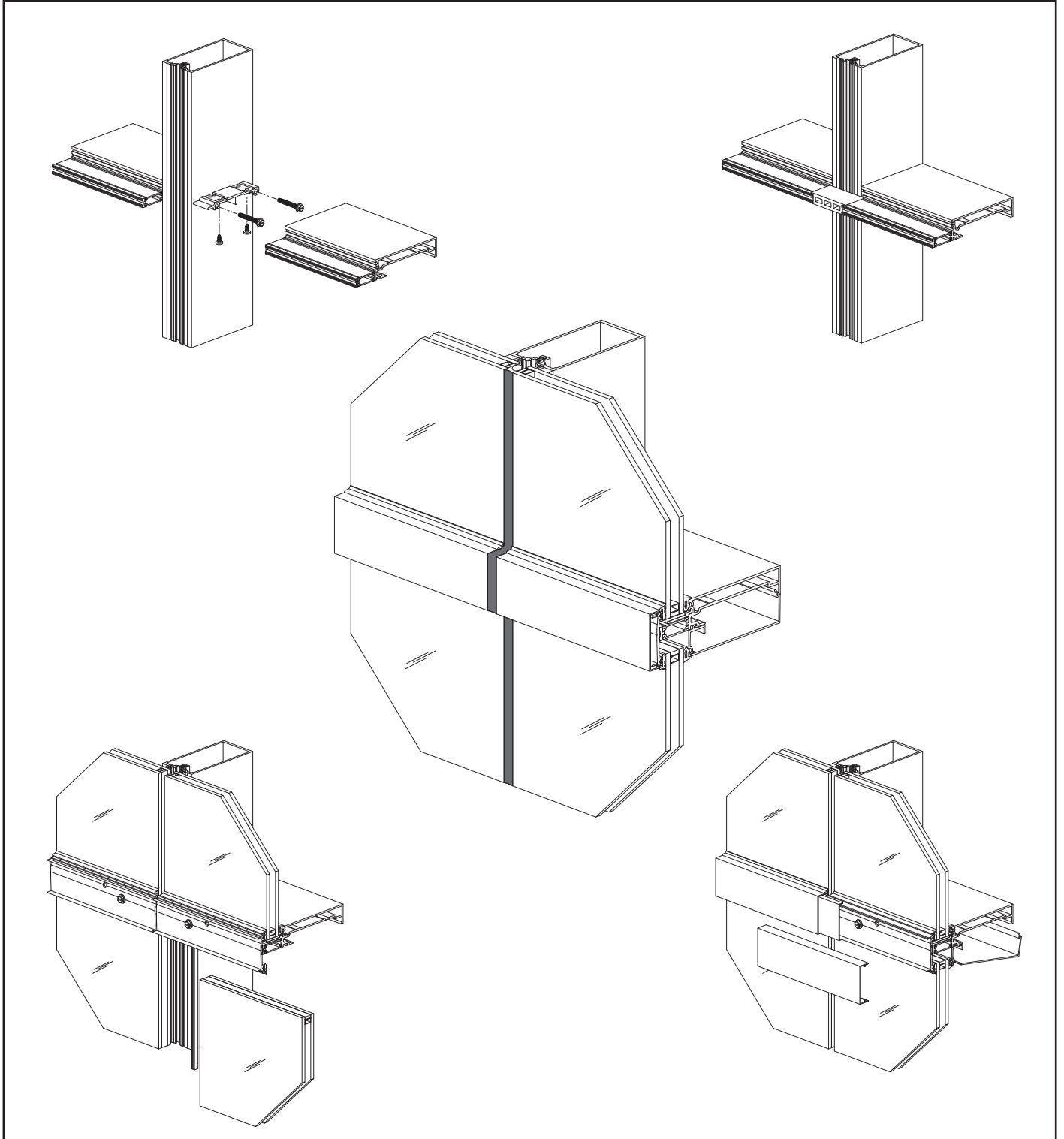

Installation Manual











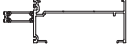
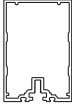









TABLE OF CONTENTS

Installation Notes	Page ii
PARTS DESCRIPTION	
YCW 750 XT IG SSG Framing Members.....	Pages 1 & 2
YCW 750 XT IG SSG Accessories	Pages 2 to 4
FRAME FABRICATION	
Frame Types/Anchoring Methods	Pages 5 to 7
Fabricate Vertical Mullions	Pages 8 & 9
Fabricate Pressure Plates	Page 10
Fabricate Horizontal/Vertical Covers	Page 11
Shear Clips for Horizontals.....	Page 12
Fabricate Head & Sill.....	Pages 13 & 14
Fabricate Intermediate Horizontal	Page 15
Fabricate/Install Mullion Splices	Pages 16 & 17
FRAME INSTALLATION	
Install Vertical Face Covers.....	Page 18
Install Jamb Mullion End Caps.....	Page 19
Attach SSG Mullion End Caps	Page 20
Install Jamb & Vertical Mullions.....	Pages 21 & 22
Install Wind Load / Dead Load Anchors.....	Pages 23 to 25
Head / Horizontal / Sill Attachment	Page 26
Install Door Subframes	Page 27
90° Outside Corner Assembly	Page 28
Perimeter Sealant.....	Page 29
GLAZING	
Install Joint Plugs.....	Pages 30 & 31
Install Pressure Plates & Setting Blocks	Page 32
Install Exterior Gaskets.....	Page 33
Pressure Plate Layout & Assembly	Page 34
Install Glass & Anti-Walk Blocks	Pages 35 & 36
Install Interior Gaskets.....	Pages 37 & 38
Install Interior Covers.....	Page 39
Apply Interior Sealant to SSG Mullion.....	Page 40
Install Exterior Horizontal Face Covers	Page 41
Apply Exterior Weatherseal.....	Page 42











Installation Notes

1. Do not drop, roll or drag boxes of aluminum framing. Move and stack boxes with proper support to prevent distortion. If fork lifts are used be especially careful about striking the boxes when lifting or moving.
2. Store in a dry, out of the way area. If rain exposure, condensation or any water contact is likely, then all packaging material should be removed. Wet packaging materials will discolor and may stain aluminum finishes and paints.
3. All materials should be checked for quality and quantity upon receipt, YKK AP must be notified immediately of any discrepancies in shipment. Check to make sure that you have the required shims, sealants, supplies and tools necessary for the installation.
4. Carefully check the openings and surrounding conditions that will receive your material. Remember, if the construction is not per the construction documents, it is your responsibility to notify the general contractor in writing. Any discrepancies must be brought to the general contractor's attention before you proceed with the installation.
5. Gather your shop drawings, materials, packing list, and this installation manual. Carefully review parts location, the sequence it goes therein, when you glaze it and how you seal it. Installation instructions are of a general nature and may not cover every condition you will encounter. The shop drawings and/or installation manuals were prepared specifically for the product.
6. Any material substitutions must be of equal or greater quality.
7. Make certain that material samples have been sent for compatibility testing for all manufacturer's sealants involved. Make certain sealants have been installed in strict accordance with the manufacturer's recommendations and specifications.
8. Remember to isolate, in an approved manner, all aluminum from uncured masonry or other incompatible materials.
9. System-to-structure fasteners are not supplied by YKK AP. Fasteners called out on shop drawings are to indicate minimum sizes for design loading.
10. Entrances are to be installed plumb, square, level and true.
11. If any questions arise concerning YKK AP products or their installation, contact YKK AP for clarification before proceeding.
12. YKK AP storefront and/or curtain wall framing is typically completed before drywall, flooring and other products which may still be in process. Take the extra time to wrap and protect the work produced.
13. Cutting tolerances are plus zero (0"), minus one thirty second (-1/32") unless otherwise noted.
14. Check our website, www.ykkap.com, for the latest installation manual update prior to commencing work.

FRAMING MEMBERS

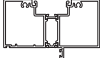



	Vertical Mullion with Integral Cover 2-1/2" x 5-1/4"	BE9-3970		Vertical Mullion 2-1/2" x 3-3/4"	BE9-3362
	Vertical Mullion 2-1/2" x 5-1/4"	BE9-3981		Horizontal (OG) 2-1/2" x 3-3/4"	BE9-3359
	Horizontal (OG) 2-1/2" x 5-1/4"	BE9-3976		Horizontal (OG) 2-1/2" x 3-3/4"	BE9-3366
	Horizontal (OG) 2-1/2" x 5-1/4"	BE9-3986		Head (OG) 2-1/2" x 3-3/4"	BE9-3354
	Head (OG) 2-1/2" x 5-1/4"	BE9-3975		Sill (OG) 2-1/2" x 3-3/4"	BE9-3365
	Sill (OG) 2-1/2" x 5-1/4"	BE9-3984		SSG Mullion 2-1/2" x 3-3/4"	E9-3423
	SSG Mullion 2-1/2" x 5-1/4"	E9-3401		Flush Filler Use With BE9-3364	E9-3336
	Flush Filler Use With BE9-3978, BE9-3983, & BE9-3984	E9-3162		Interior Cover For 3-3/4" Back Depth Only	E9-3335
	Interior Cover For 5-1/4" Back Depth Only	E9-3334		Interior Glass Stop For 3-3/4" Back Depth Only	E9-3996
	Interior Glass Stop For 5-1/4" Back Depth Only	E9-3957		Interior Glass Stop For 1" Glazing	E9-3968
	Vertical Mullion with Integral Cover 2-1/2" x 3-3/4"	BE9-3360		Glazing Adaptor For 1/4" Glazing	E9-7650

FRAMING MEMBERS





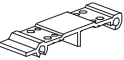

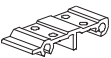
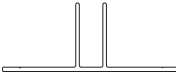









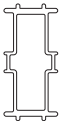

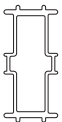
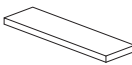
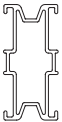

	Face Cover 2-1/2" x 3/4"	E9-1206		Single Acting Transom Bar For 25T/35T/50T Doors E2-0051 Not Included	BE9-2582
	Pressure Plate For OG Option	AS-3958		Door Jamb Flat Subframe For 25T/35T/50T Doors Use with AS-1539	BE9-1526
	PVC Perimeter Filler For 1" Glazing	E3-3665		Door Stop For 25T/35T/50T Doors E2-0051 Included Use with BE9-1526	AS-1539
	Single Acting Transom Bar For 35XT/50XT Doors* Elastomer Weathering E2-0051 Not Included	BE9-1532		1" x 1" x 1/8" Angle	E9-9302
	Door Jamb For 35XT/50XT Doors* Use with BE9-1533	BE9-1540		1-1/2" x 1-1/2" x 1/8" Angle	E9-9303
	Door Stop For 35XT/50XT Doors* Elastomer Weathering E2-0051 Not Included Use with BE9-1540	BE9-1533			

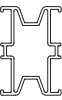
* Note: 35XT/50XT Doors to be discontinued after April 30, 2024.

ACCESSORIES

	Steel Reinf. Tube 2" x 4" x 1/8"	E1-0187		Shear Clip For 3-3/4" Back Depth Head & Sill	E1-1351
	Shear Clip For 5-1/4" Back Depth Head, Horizontal & Sill	E1-3019		Intermediate Mullion "T" Anchor For 5-1/4" Back Depth	E1-1208
	Shear Clip For 3-3/4" Back Depth Horizontal	E1-1350		SSG Mullion "T" Anchor For 5-1/4" Back Depth	E1-1222

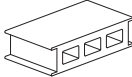
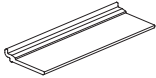











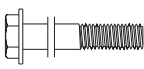

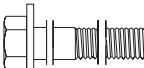

ACCESSORIES (Continued)

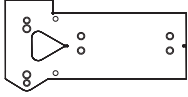
	Jamb Mullion "F" Anchor For 5-1/4" Back Depth	E1-1233		Windload Anchor Refer to Shop Drawings for Anchor Dimensions *	E1-1204
	Jamb Mullion "F" Anchor For 3-3/4" Back Depth	E1-1230		Deadload Anchor Refer to Shop Drawings for Anchor Dimensions *	E1-1205
	Jamb Mullion "T" Anchor For 3-3/4" Back Depth	E1-1229		Jamb Anchor Plate For 1" Glass	E1-3536
	Mullion Reinf. Sleeve For 5-1/4" Back Depth Vertical, 29" Long	E1-1353		Nylon Slip Pad For Windload / Deadload Anchor	E3-0103
	Mullion Splice Sleeve For 5-1/4" Back Depth	E1-1352		Side Block For 1" Glazing	E2-0177
	SSG Mullion Joint Sleeve For 5-1/4" Back Depth	E1-3620		Isolator Tape	E2-0356
	Mullion Splice Sleeve For 3-3/4" Back Depth	E1-1354		Setting Block For 1" Glazing	E2-0513
	SSG Mullion Joint Sleeve For 3-3/4" Back Depth	E1-3421		Setting Block For 1/4" Glazing	E2-9902
	Splice Sleeve For Face Cover	E1-1202		Anti-Walk Block For Deep Pocket	E2-0546
	Mullion End Cap For 1" Glazing	E1-1359		Joint Plug For 1" Glass	E2-3663
	SSG Mullion End Cap 1/4" I.D. x 1" O.D.	FW-2500 -SS		SSG Joint Plug For 1" Glass	E2-3615
	Setting Block Chair For 1" Glazing	E1-3619		Temporary Glass Retainer For 1" Glazing	E3-0001

* Note: Project specific part number.

Exact size of anchors should be determined from loads calculated on each individual curtain wall frame.

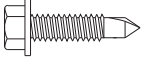
ACCESSORIES (Continued)

	Interior Glazing Gasket (OG) 5/16" Face Clearance	E2-0128		1/2"-13 Nut HHMS Zinc Plated Steel For Attachment of Mid-Anchors	HM-2500
	Push-In Glazing Gasket For SSG Elevations	E2-9914		1/2"-13 x 2" HHMS Zinc Plated Steel For Attachment of Mid-Anchors @ Jamb	HM-5032
	Exterior Glazing Gasket (IG) For SSG Elevations	E2-9801		1/2"-13 x 4-1/2" HHMS Zinc Plated Steel For Attachment of Mid-Anchors	HM-5072
	Arrow Spacer For SSG Mullions	E2-0535		#10 x 5/8" PHSMS Type AB, Zinc Plated Steel	PC-1010
	Elastomer Weathering Used with BE9-1532 & BE9-1533	E2-0051		#12 x 1/2" PHSMS Type AB, Zinc Plated Steel	PC-1208
	Drill Fixture	H-7216		#12 x 5/8" PHSMS Type AB, Zinc Plated Steel	PC-1210
	#10 x 3/4" FHSMS Type AB, Zinc Plated Steel For attachment of face cover splice	FC-1012		#12 x 1/2" PHSMS Type F, Stainless Steel	PF-0808-SS
	#12 x 3/4" FHSMS Type AB, Zinc Plated Steel For attachment of Corner Shear Clip	FC-1212		1/2" Lock Washer Zinc Plated Steel For Attachment of Mid-Anchors	WS-5000
	#14-20 x 1" TEK HWHS , Zinc Plated Steel For Attachment of Press. Plate	TEK-1416		1/2" Flat Washer Zinc Plated Steel For Attachment of Mid-Anchors	WW-5000
	1/4"-20x1-3/4" HWHS Type F, Zinc Plated Steel, For Attachment of Shear Block	HR-2528-W1			

FRAME FABRICATION

FRAME TYPES / ANCHORING METHODS:

Note: The following is a guideline for types of frames. Refer to the shop drawings or consult YKK AP for exact layout of frames.

These installation instructions are to be used in conjunction with approved shop drawings. Consult shop drawings for anchorage of mullions to structure.

Larger units require being stick assembled in place.

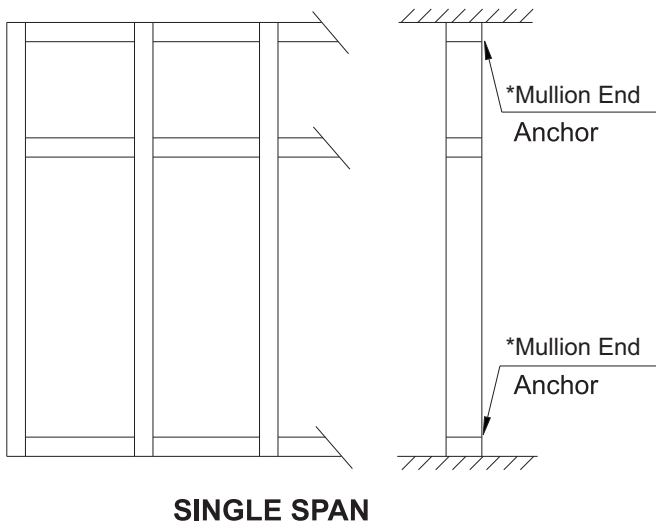

Smaller units may be assembled on the ground and tipped in place.

Note: If YKK does not prepare the shop drawings for the project, a qualified engineer must approve all anchors and mullions for wind load and dead load.

*Mullion end attachment will be “F” and/or “T” anchors. Refer to shop drawings or consult YKK AP.

Note: Structure must be capable of resisting all loads imposed by anchor reactions.

Fabrication of YCW 750 IG varies depending on which anchors are required for a given project.

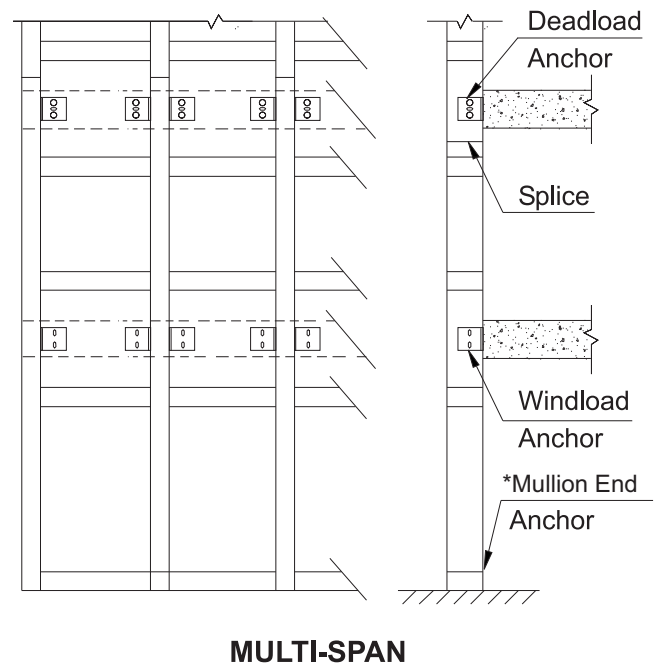
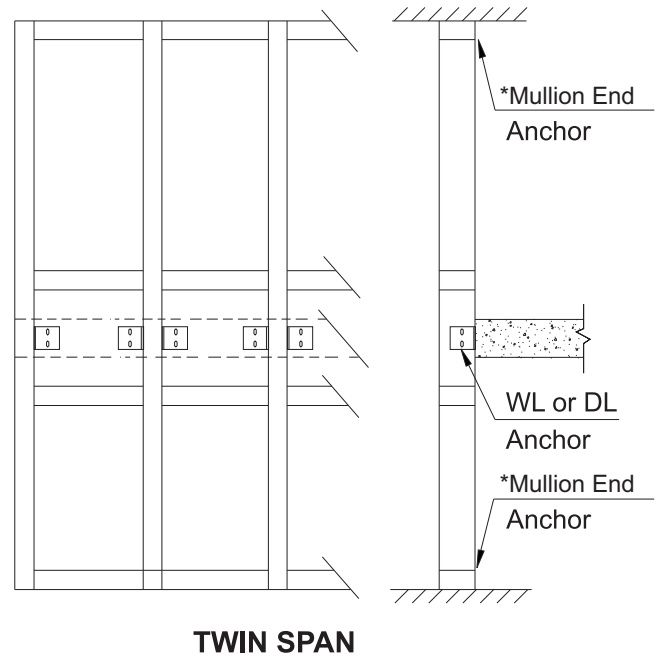

FRAME FABRICATION

Using mullion end anchors:

YCW 750 XT IG has two possible end anchoring conditions: "T" for intermediate mullions and "F" for jamb mullions.

Jamb and intermediate mullions should be pre-assembled with shear clips, end anchors, and steel or aluminum reinforcing if necessary.

Framing members:

-Open back members are used for all head, horizontal and sill members to slide over the shear clips.

Head Members (1" Glazing):
 BE9-3354 for 3-3/4" back depth
 BE9-3977 for 5-1/4" back depth

Horizontal Members (1" Glazing):
 BE9-3359 for 3-3/4" back depth
 BE9-3986 for 5-1/4" back depth

Sill Members (1" Glazing):
 BE9-3365 for 3-3/4" back depth
 BE9-3984 for 5-1/4" back depth

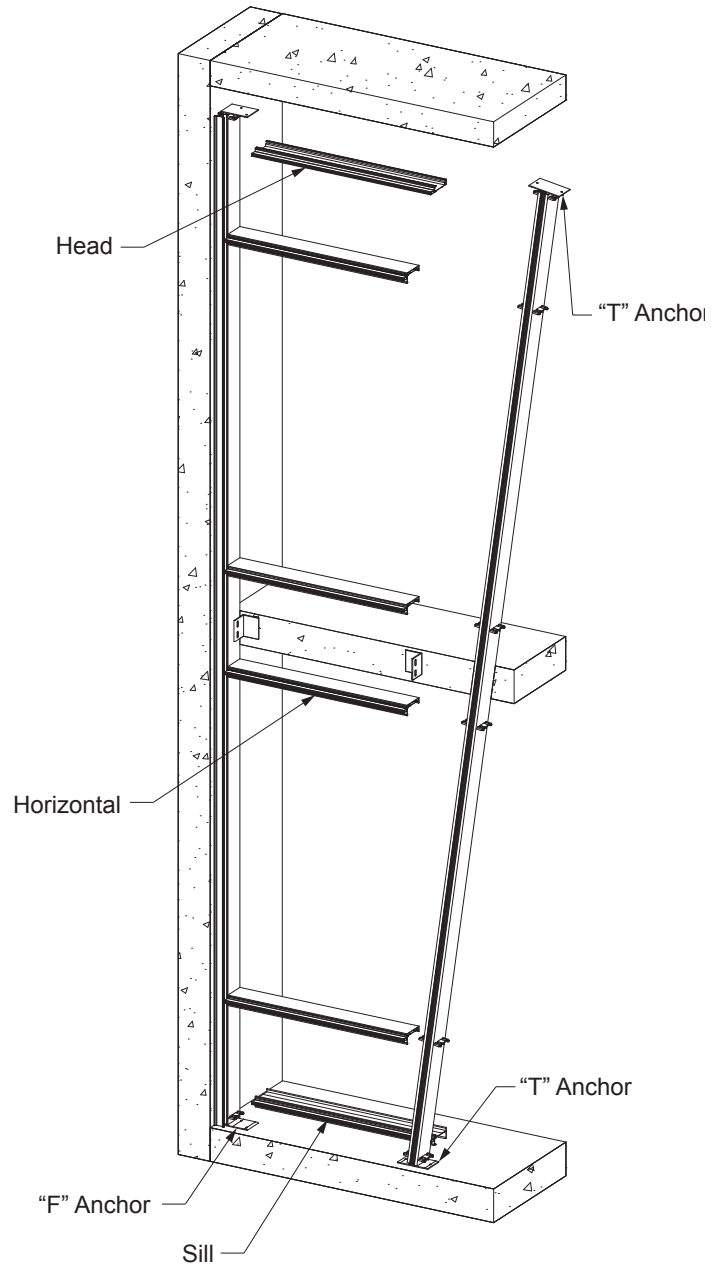

Note: When using stick built construction, check for plumb, level, and overall frame width every fifth mullion. This helps to avoid the build up of cumulative tolerance errors. Also check that all anchors are secure and firmly attached to the building.

FRAME FABRICATION

FABRICATE MULLIONS FOR 3-3/4" BACK DEPTH

STEP 1

-Cut all intermediate and jamb mullions to dimensions as shown on shop drawings.
Allow 1/2" for splices and 3/4" caulk joint around the perimeter of the frame.

STEP 2

-Mullion hole locations for attachment of shear clips, E1-1350 & E1-1351, are shown below:
E1-1351 for head & sill and E1-1350 for intermediate horizontals.
-Locate and drill 0.213" diameter (#3 drill bit) holes in the locations indicated in **Detail 1**, or use a short piece of head, horizontal and sill with shear clip attached as a template.

Note: Hole locations for shear clips vary for head, horizontal and sill conditions.
Also note that the holes for the head and sill shear clips **do not** line up.

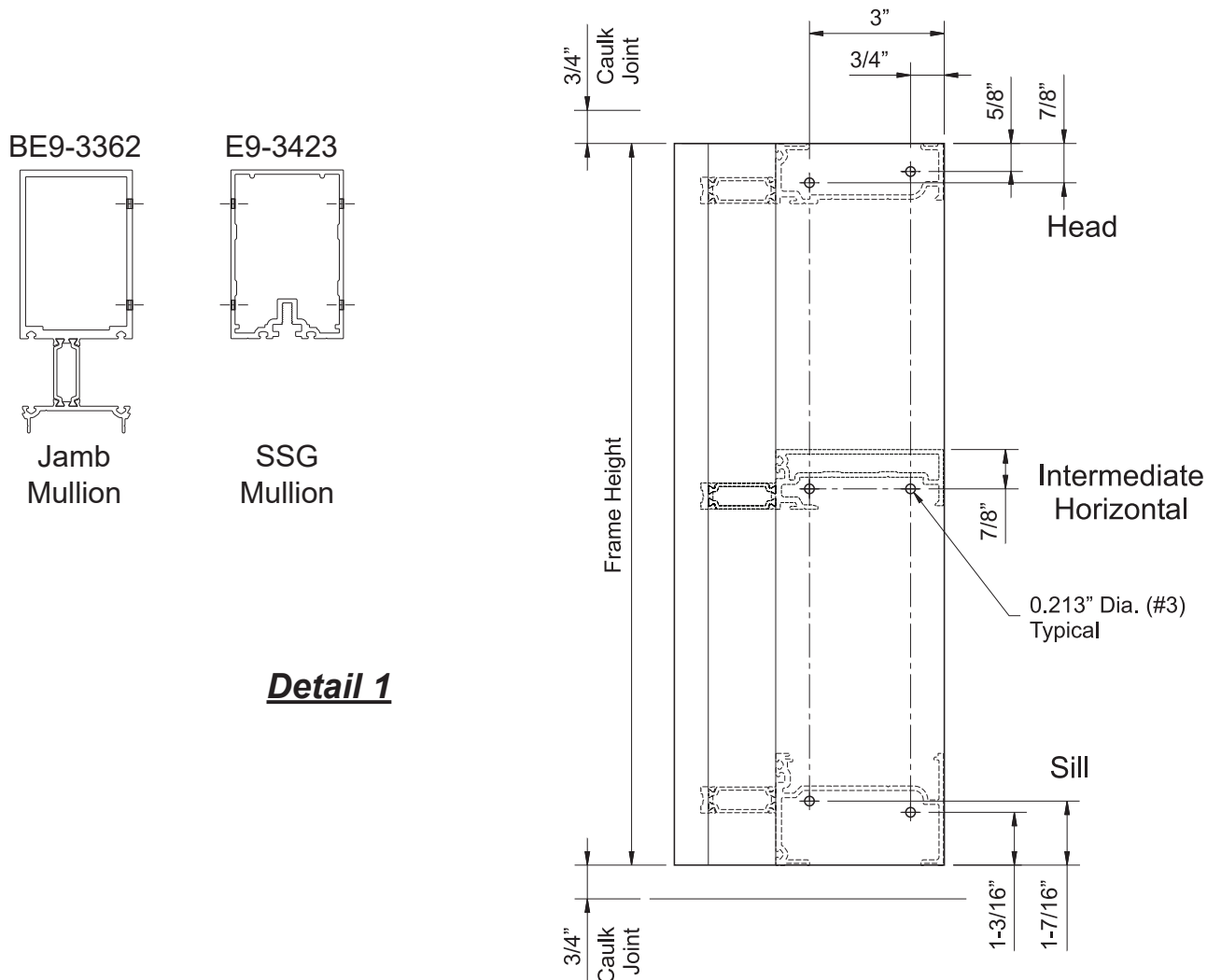

FRAME FABRICATION

FABRICATE MULLIONS FOR 5-1/4" BACK DEPTH

STEP 1

-Cut all intermediate and jamb mullions to dimensions as shown on shop drawings.
Allow 1/2" for splices and 3/4" caulk joint around the perimeter of the frame.

STEP 2

-Mullion hole locations for shear clips, E1-3019, are shown below:
-Locate and drill 0.213" (#3) dia. holes for HF-2528-W1 screws in the locations indicated in **Detail 2**, or by using the drill fixture.

Note: Hole locations for shear clips vary for head, horizontal and sill conditions.

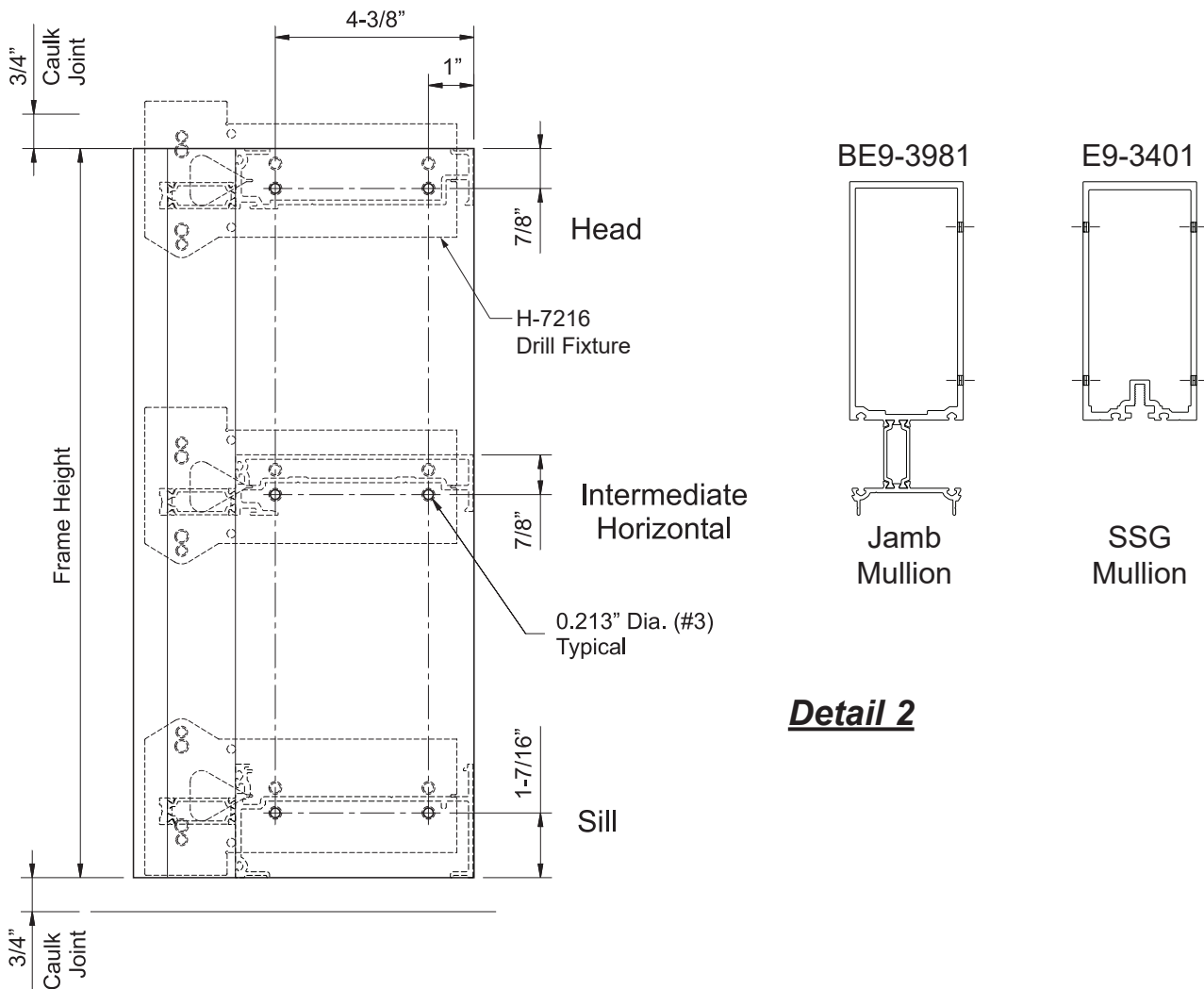

FRAME FABRICATION

FABRICATE MULLIONS FOR DOOR JAMB APPLICATION

Door jambs must use the YCW 750 XT IG captured mullion.

STEP 1

-Cut all intermediate and jamb mullions to dimensions as shown on shop drawings.
Allow 1/2" for splices and 3/4" caulk joint at the top of the frame.

STEP 2

-Mullion hole locations for attachment of shear clips are shown below:
E1-1351 for head & sill and E1-1350 for intermediate horizontals.
-Locate and drill 0.213" (#3) dia. holes for HF-2528-W1 screws in the locations indicated in **Detail 3**, or by using the drill fixture.

Note: Hole locations for shear clips vary for head, horizontal and sill conditions.
Also note that the holes for the head and sill shear clips **do not** line up.

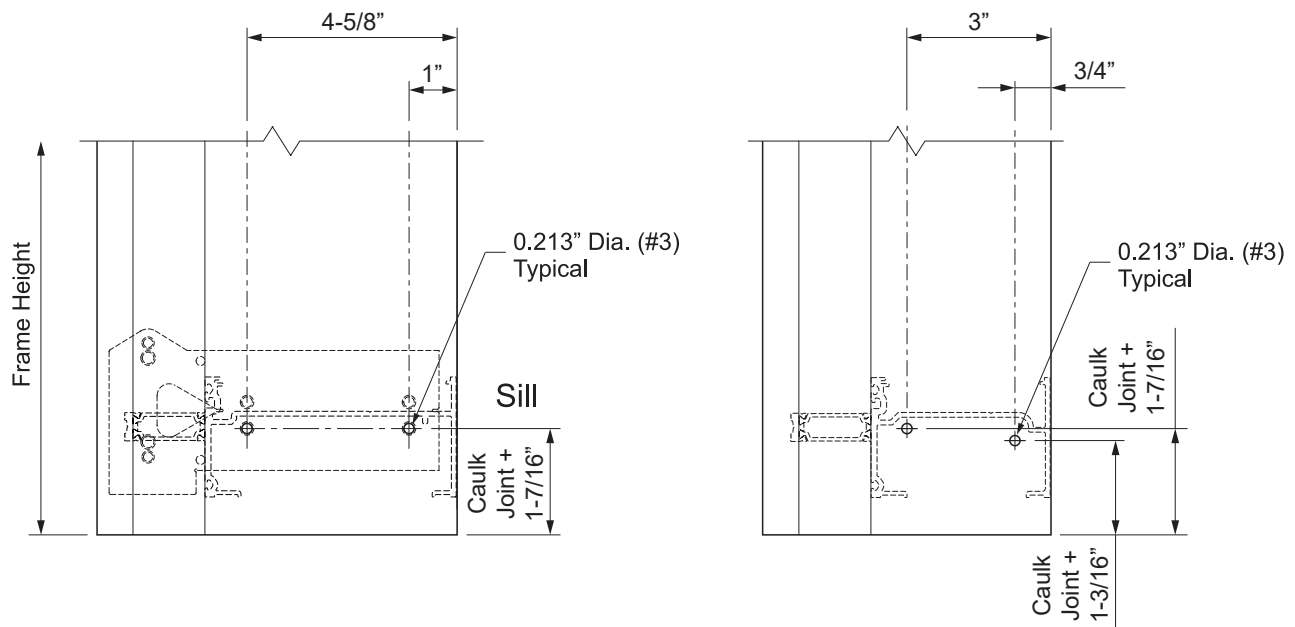

Detail 3

FRAME FABRICATION

STEP 3 FABRICATE PRESSURE PLATES

Note: In order to glaze from the interior, the minimum horizontal Daylight Opening must be 24" or greater.

-Cut horizontal pressure plates as shown in **Detail 4**.

-Cut pressure plates between jamb and intermediate mullions to D.L.O. plus(+) 1-1/16".

-Cut pressure plates between intermediate verticals to D.L.O. plus(+) 2-3/8".

-For pressure plates spanning more than one bay, cut them to the centerline to centerline dimension between mullions minus(-) 1/8".

-Pressure plate stock lengths have 0.281" dia. holes factory punched every 9".

Drill additional holes if required to ensure that end holes are 1-1/2" from the end at the jamb or 2-9/16" from the end at the ssg mullion.

-Drill two 0.313" diameter weep holes 3" from each end and one at the centerline of the pressure plate for each lite of glass. If the space between the weep holes exceeds 3', additional weep holes should be drilled to ensure that there is no more than 3' between the weep holes.

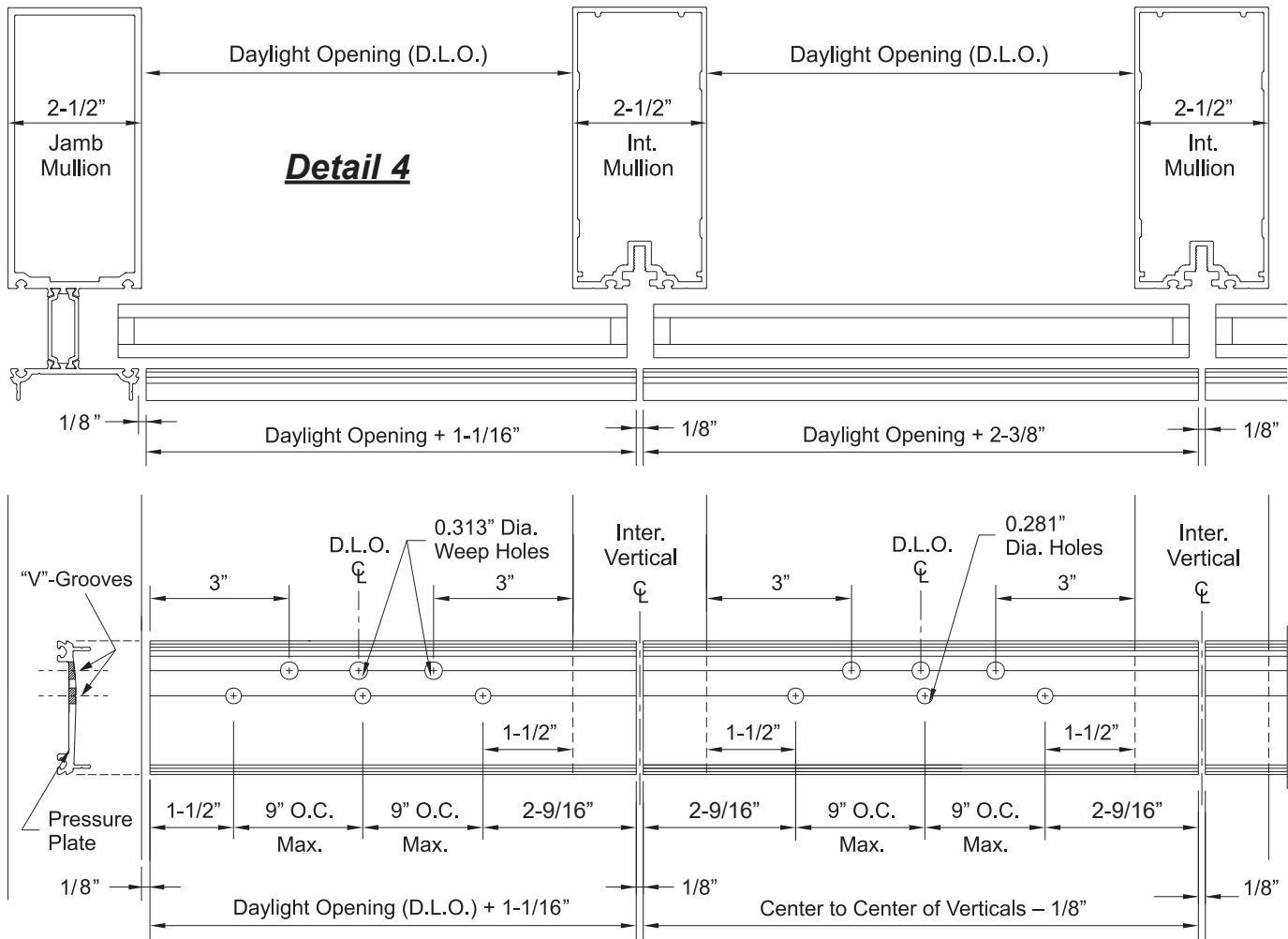

FRAME FABRICATION

STEP 4 FABRICATE FACE COVERS

-Cut jamb face covers to the same length as the jamb mullions unless the mullions are spliced. If jamb mullions are spliced, cut jamb covers to accommodate for the 1/2" expansion joint as shown in **Step 8** on **Pages 16 & 17**.

-Cut horizontal covers 1/32" short of jamb mullion on jamb side of frame. Covers are to be spliced at every third light of glass at the centerline of vertical mullion. Optionally, covers may be spliced at every centerline of vertical mullions.

-Drill two 0.313" diameter weep holes as shown, at 1/3 points of each daylight opening. See **Detail 5**.

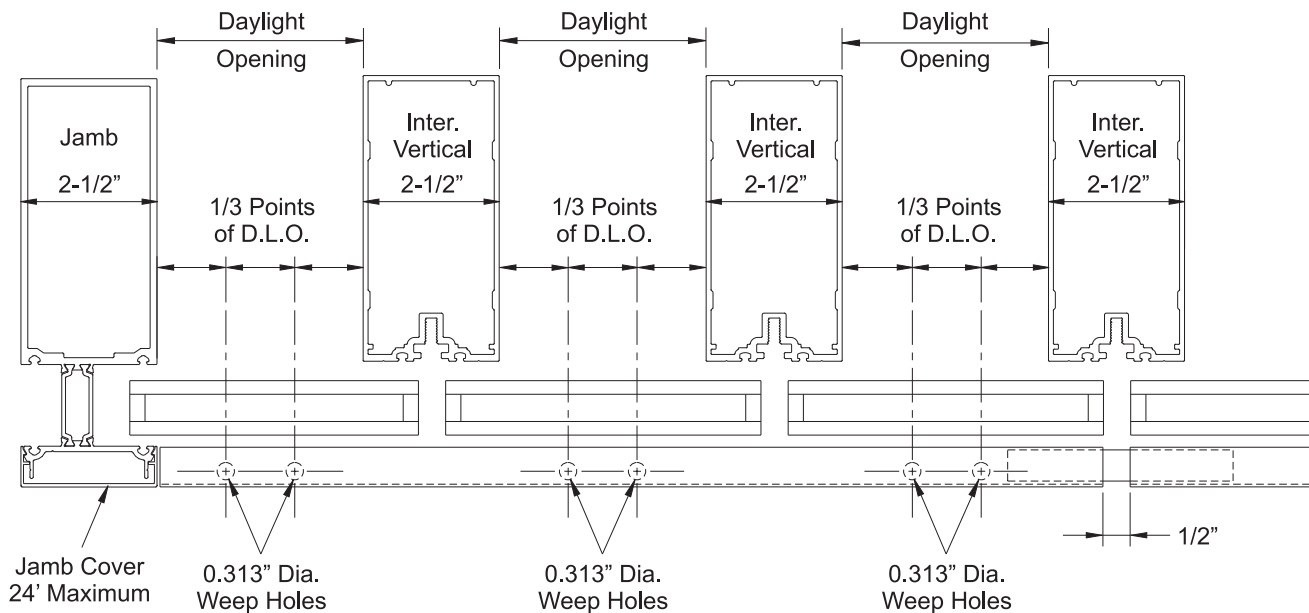

Detail 5

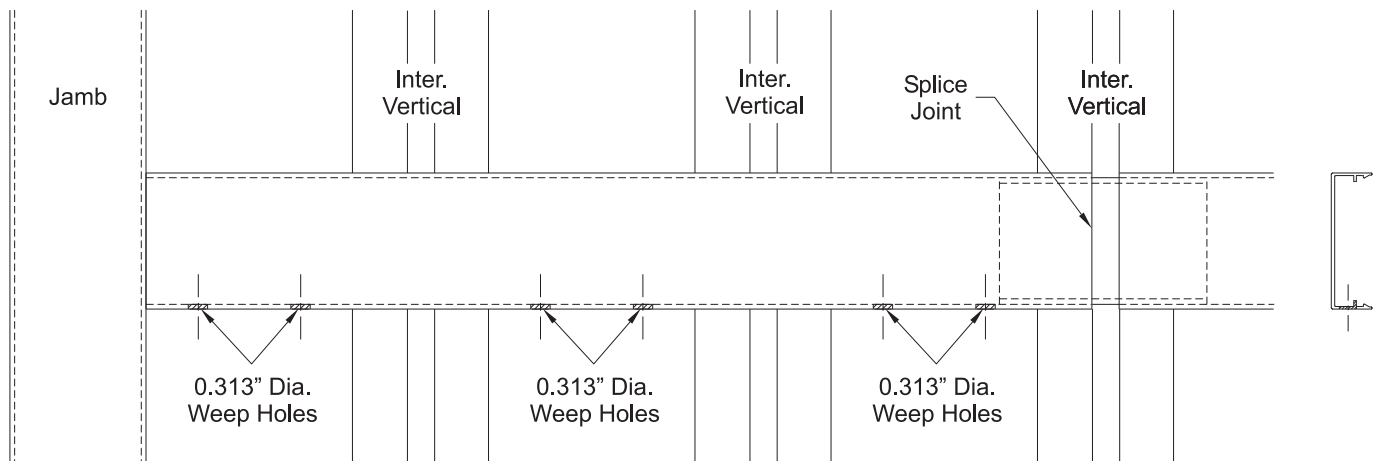

FRAME FABRICATION

**STEP 5
SHEAR CLIPS FOR HORIZONTALS**

- Attach shear clips to the mullions using two HF-2528-W1 screws for each clip:
 - E1-1350 for 3-3/4" back depth intermediate horizontals.
 - E1-1351 for 3-3/4" back depth head and sill members.
 - E1-3019 for all 5-1/4" back depth horizontal members.

See **Detail 6**.

3-3/4" BACK DEPTH

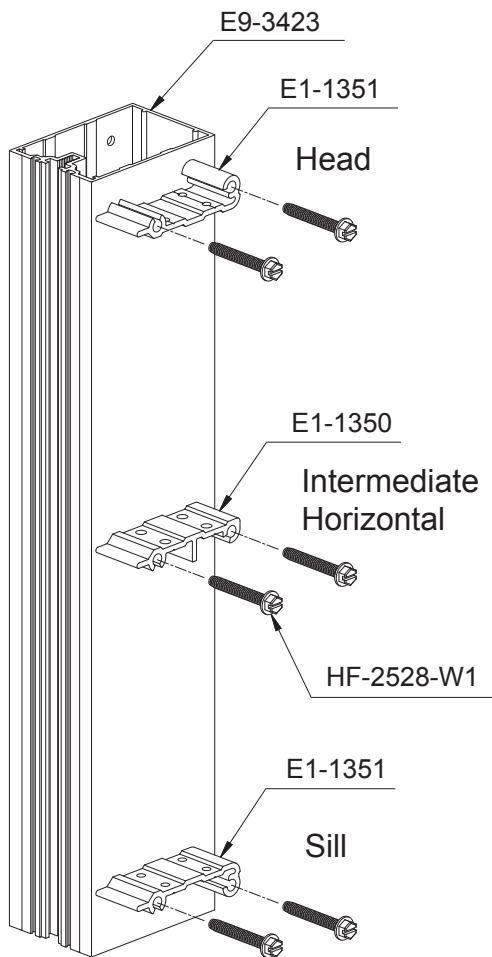

5-1/4" BACK DEPTH

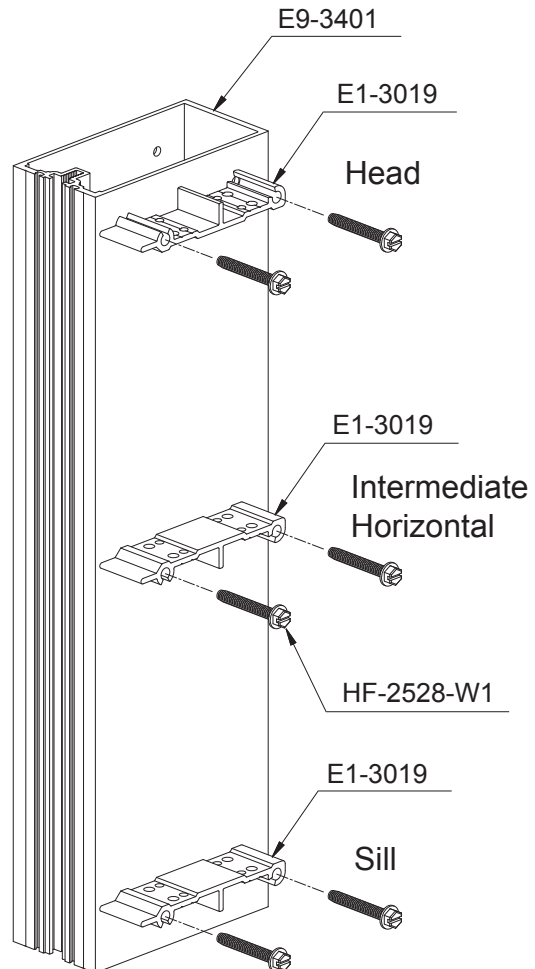

Detail 6

FRAME FABRICATION

STEP 6 FABRICATE OF HEAD & SILL MEMBERS

- Cut head and sill members to the daylight opening between verticals.
- Cut all glass stops, flush fillers and interior covers to the daylight opening minus(-) 1/32". Interior covers, E9-3334 & E9-3335, and flush fillers, E9-3162, are only required in vision areas.
- Drill 0.236" diameter (#B drill bit) holes 1" from each end of the head and sill members along the "V"-grooves.
- Weep holes must be drilled for head and sill members:
- Drill 0.313" diameter (#O drill bit) weep holes 3" from each end and one in the middle of the mullion along the "V"-groove on the outside face of the sill member.

Note: The head member must be turned over so that the "V"-grooves are facing up.
Drill appropriate size clearance holes at each end of the mullion according to shop drawings or engineering calculations to clear anchor bolts and nuts.

See **Detail 7 & 7A**.

Fabrication of Head Member

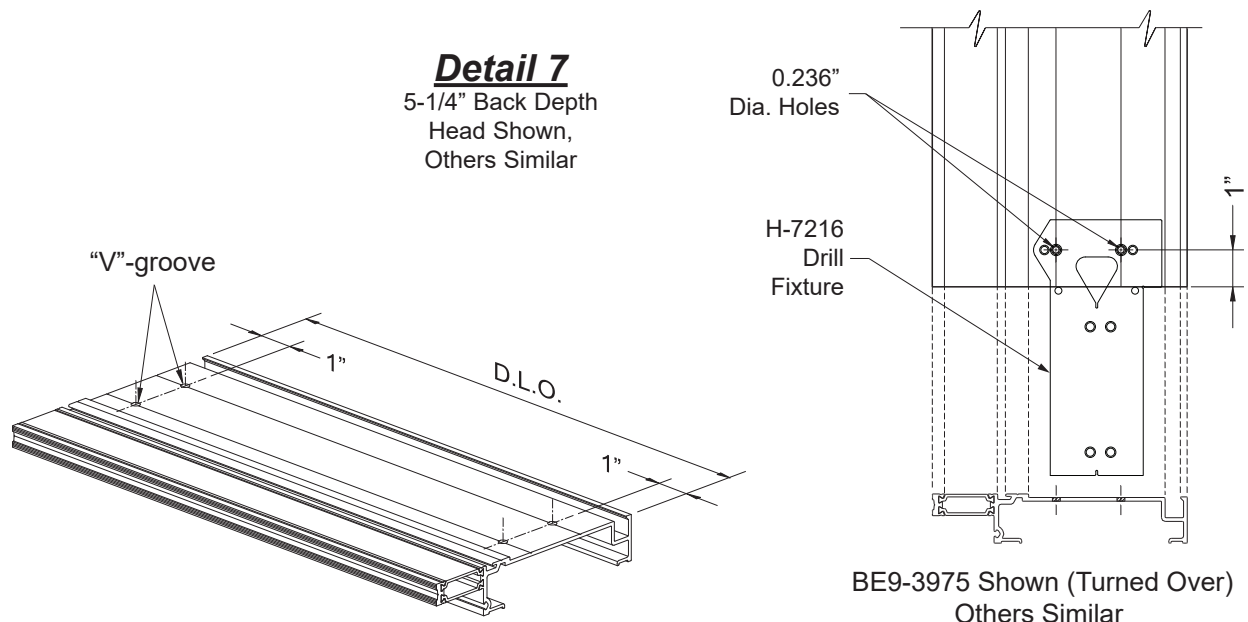

FRAME FABRICATION

**STEP 6 (Continued)
FABRICATE OF HEAD & SILL MEMBERS**

Fabrication of Sill Member

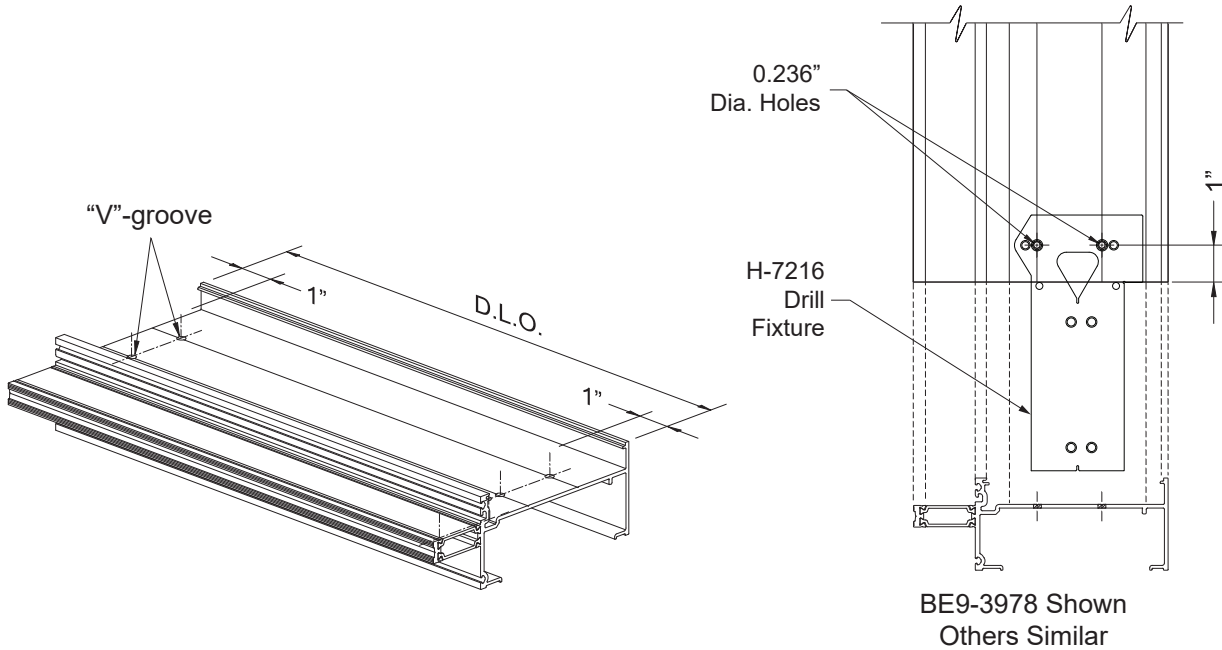

Detail 7A
5-1/4" Back Depth
Sill Shown,
Others Similar

FRAME FABRICATION

STEP 7
FABRICATE OF INTERMEDIATE HORIZONTALS

- Cut horizontal members to the daylight opening between verticals.
- Cut all glass stops, flush fillers and interior covers to the daylight opening minus(-) 1/32". Interior covers, E9-3334 & E9-3335, are only required in vision areas.
- Drill 0.189" diameter (#12 drill bit) holes 1" from each end of the horizontal members along the "V"-grooves.

Caution: Holes drilled to attach intermediate horizontals are smaller than those drilled to attach head & sill members.

Note: The horizontal member must be turned over so that the "V"-grooves are facing up.

- Weep holes must be drilled for the intermediate horizontal members:
- Drill 0.313" diameter (#0 drill bit) weep holes 3" from each end and one in the middle of the mullion along the "V"-groove on the outside face of the horizontal member.

See **Detail 8**.

Fabrication of Horizontal Member

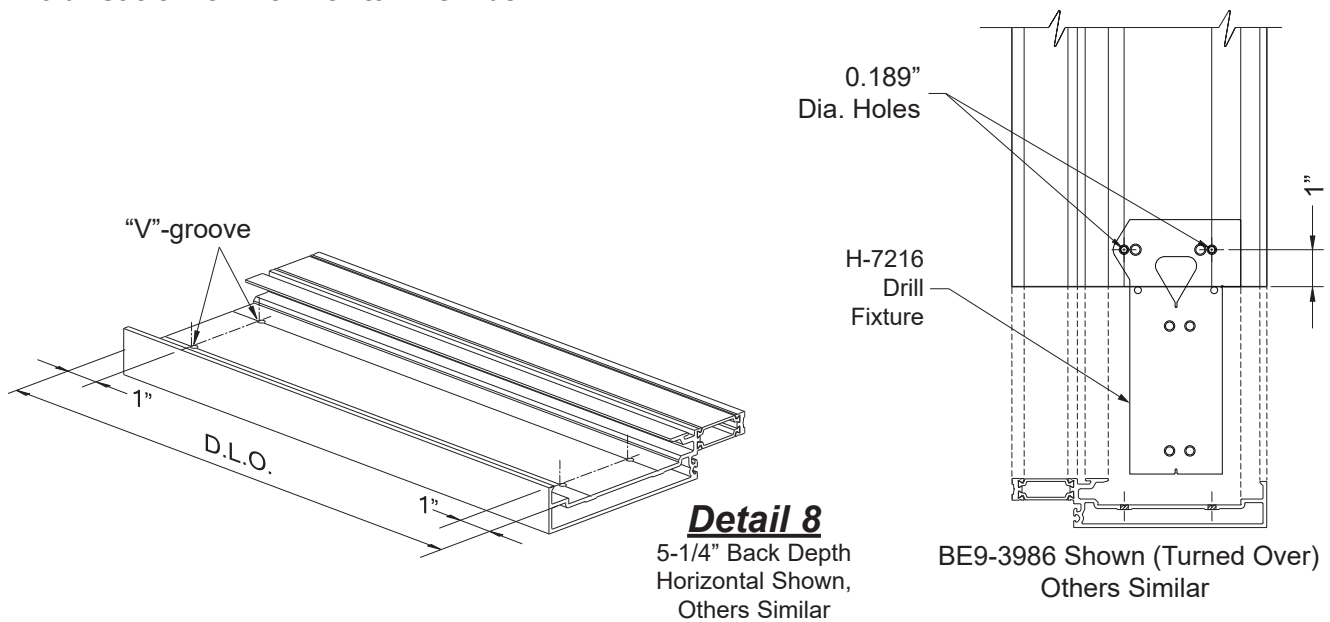

FRAME FABRICATION

STEP 8

FABRICATE/INSTALL MULLION SPLICES (SSG MULLION)

Drill holes for splice attachment:

- From the top of the vertical measure down and draw a line from 1" and 2" from the top of the mullion.
- For 5-1/4" deep mullions mark a location along this line 2-9/16" from the back of the mullion.
- Drill a 0.236" dia. (#B drill bit) hole at each location and countersink for a #12 flathead fastener.
- Repeat the previous steps on the other side of the vertical.

- Clean all surfaces as recommended by the sealant manufacturer.
- Apply bond breaker tape to the faces of the splice sleeves.

Install splice sleeve:

- Carefully slide the splice sleeve, E1-3620, down into the end of the mullion.
- Using the holes previously drilled in the mullion, drill 0.189" dia. (#12 drill bit) holes in the splice sleeve.
- Attach the splice sleeve with two FC-1212 fasteners on each side of the mullion.

See **Detail 9**.

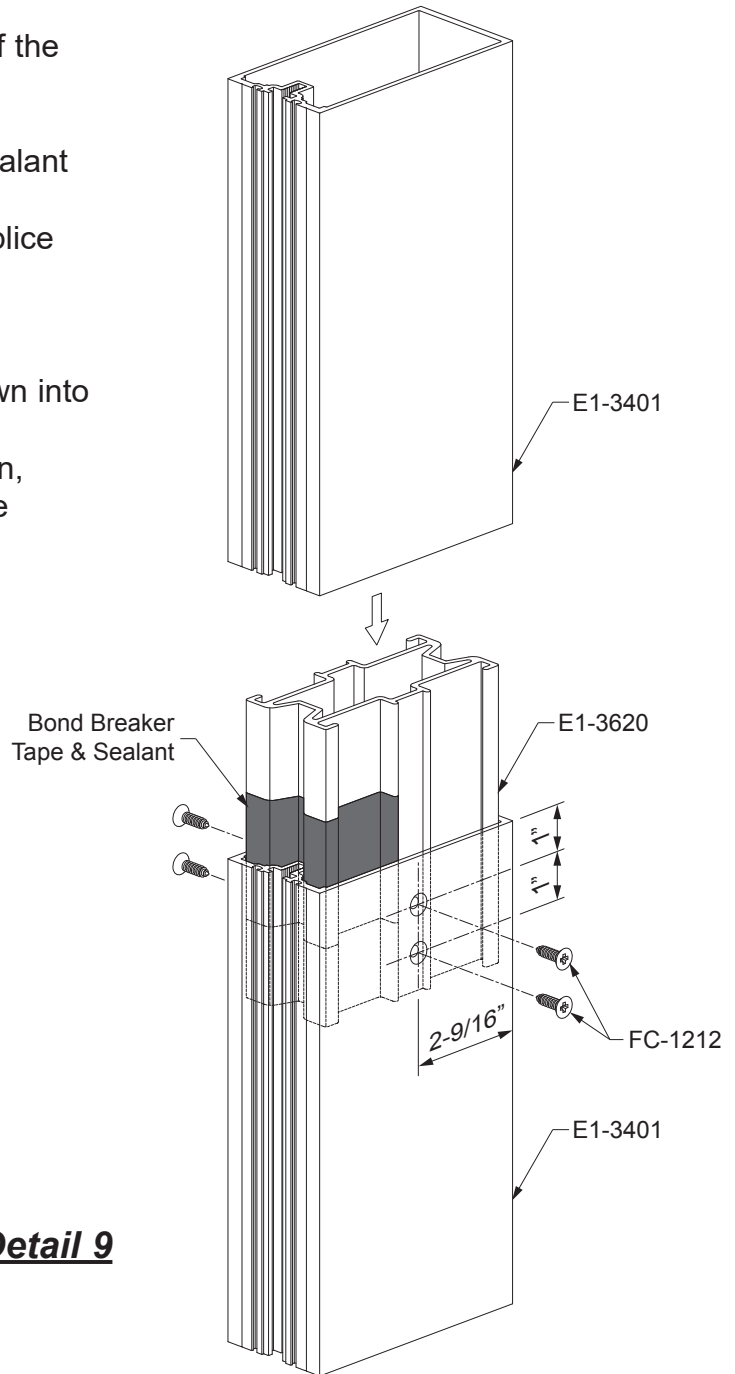

Detail 9

FRAME INSTALLATION

STEP 8 (Continued)

FABRICATE/INSTALL MULLION SPLICES (JAMB)

- Clean all surfaces as recommended by the sealant manufacturer.
- Apply bond breaker tape to the faces of the splice sleeves.

Assemble Mullion Splice:

- Apply sealant to the projected portion of the splice sleeve.
- Carefully slide the next mullion down onto the splice sleeve.
- Use a 1/2" temporary shim to properly locate the upper mullion.
- Secure upper mullion to anchor and remove temporary shim.
- Apply and tool sealant onto the face and sides of the splice sleeve to create a water tight joint.

Install Lower Face Cover:

- Snap lower face cover onto lower mullion.
- Apply bond breaker tape to upper portion of cover splice sleeve only.
- After installing upper cover, apply and tool sealant onto the face and sides of the splice sleeve.

See **Detail 10**.

Note: Mullions and face covers are staggered at splice locations.

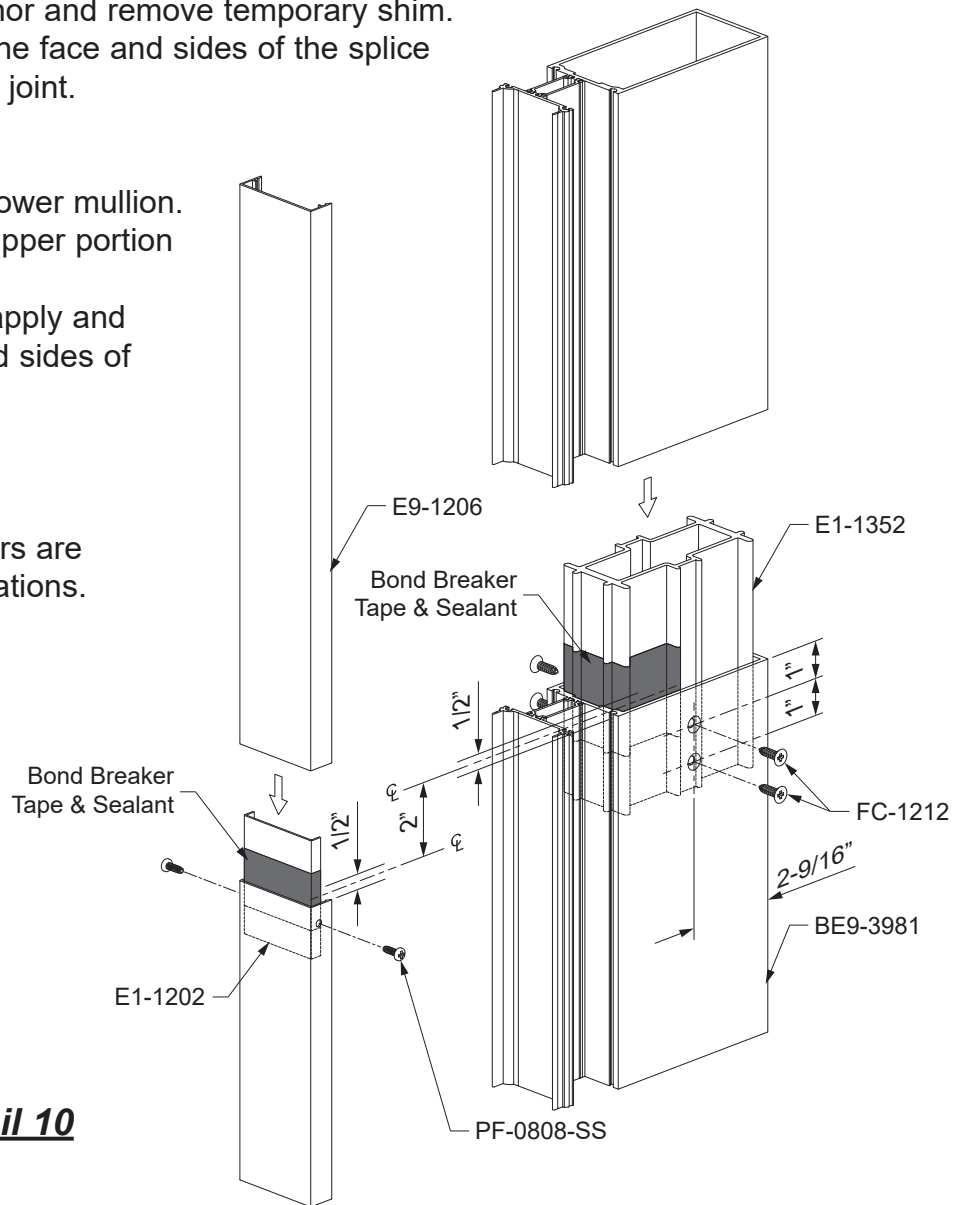

Detail 10

FRAME INSTALLATION

STEP 9 INSTALL VERTICAL FACE COVERS

-Snap on perimeter pocket fillers, E3-3665, into the heads, sills, and jambs.

See **Detail 11**.

-Snap on exterior vertical covers, E9-1206, using a mallet and a clean scrap piece of lumber. Start at one end and carefully tap in the vertical cover working down to the other end.

-To prevent vertical face covers from walking due to thermal expansion and contraction, an anti-walk screw must be installed for each vertical face cover installed.

-Drill a 0.141" dia. hole through the cover and mullion and install a FC-0808 fastener at the center of the intermediate horizontal closest to the midpoint of the vertical face cover.

See **Detail 12**.

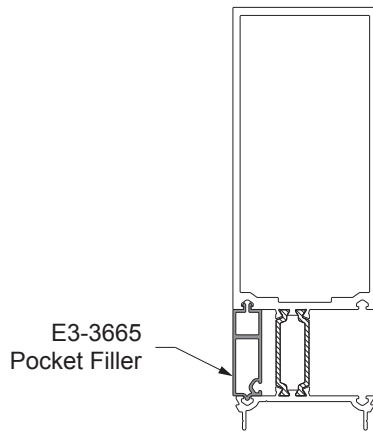

E3-3665
Pocket Filler

Detail 11
5-1/4" Back Depth
Mullion Shown,
Others Similar

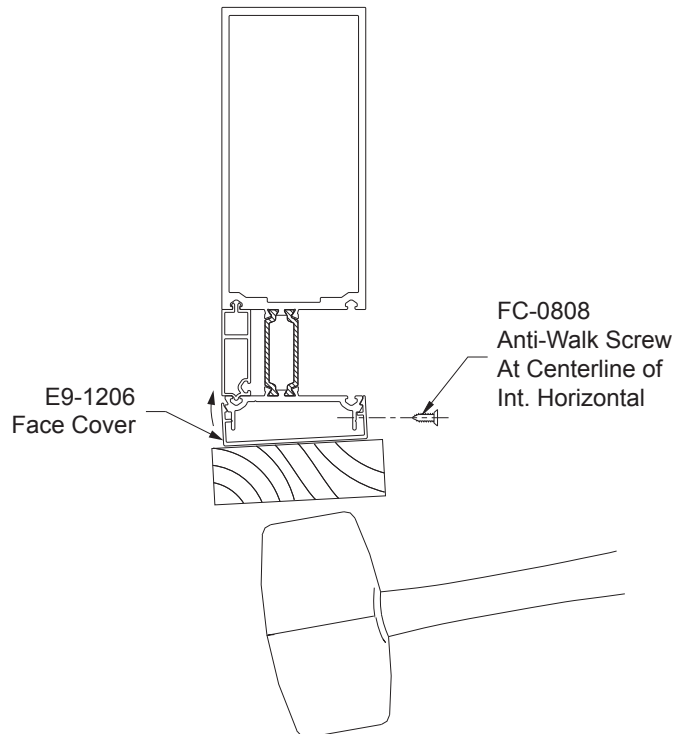

E9-1206
Face Cover

FC-0808
Anti-Walk Screw
At Centerline of
Int. Horizontal

Detail 12
5-1/4" Back Depth
Mullion Shown,
Others Similar

FRAME INSTALLATION

STEP 10 INSTALL JAMB MULLION END CAPS

-Apply sealant at the top and bottom of mullions and jambs along the back face from reglet to reglet and along the mullion web prior to installing the mullion end caps:

E1-1359 for 1" glazing.

-Install the mullion end caps onto the mullion at the top and bottom using two PC-1010 fasteners prior to erecting the verticals.

-Seal all screw heads.

-Apply and tool sealant along the intersection of the end cap and vertical at the top and bottom of the mullion.

See **Detail 13**.

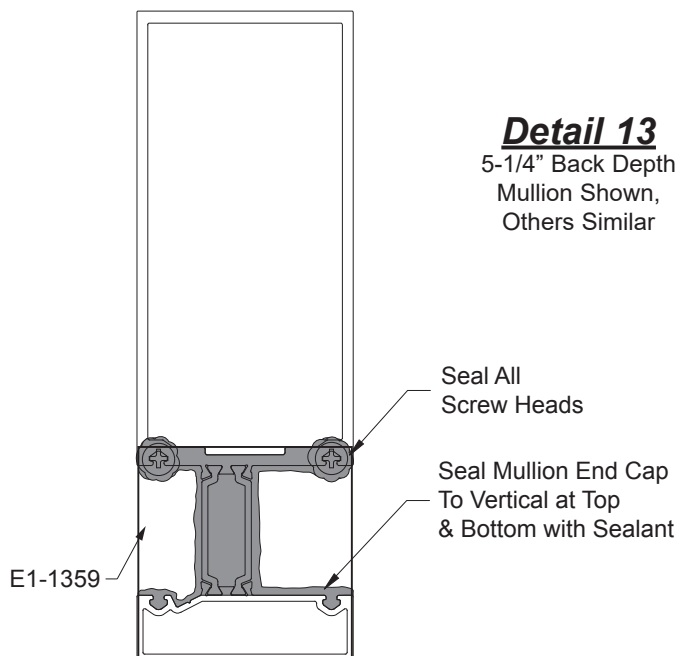
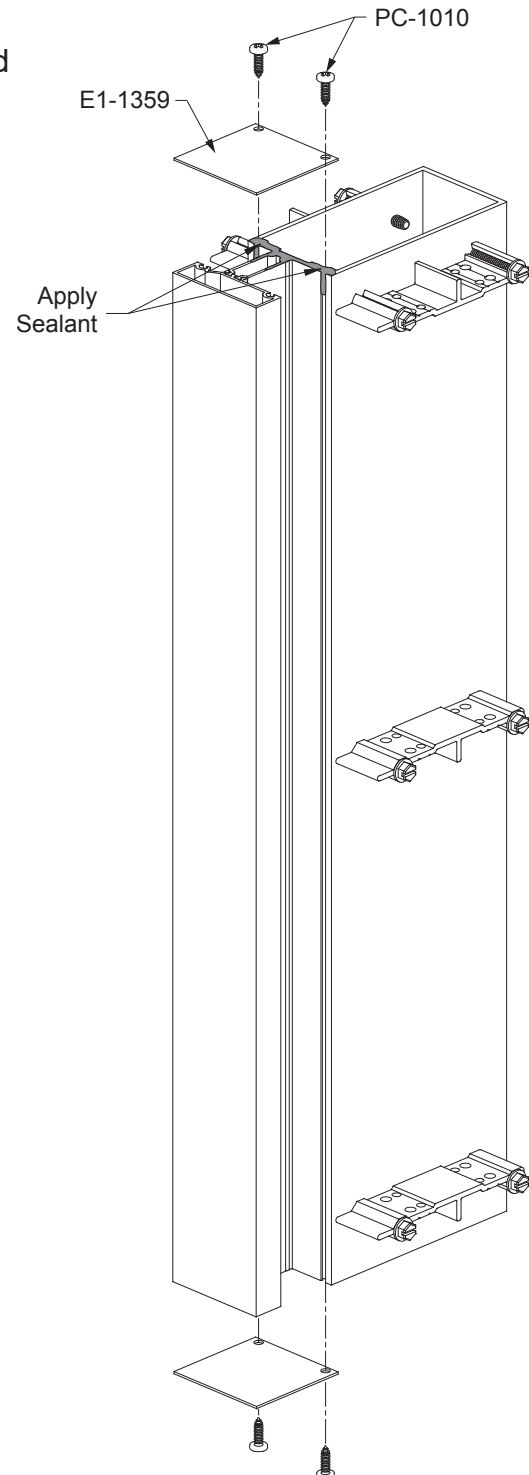

FRAME INSTALLATION

STEP 11 ATTACH SSG MULLION END CAPS

Mullion end caps are required at the head and sill of jamb and mullions.

- Clean the mullion ends and mullion end caps with a cleaner and method approved by the sealant manufacturer.
 - Apply sealant to the spline cavity and along the front of the mullions on both ends prior to installing mullion end caps, FW-2500-SS. Also apply sealant to the reglets at both ends of the mullion.
 - Attach the mullion end caps to each end of the mullion with FC-1410-SS fasteners as shown in **Detail 14**.
 - Tool the excess sealant flush between the mullion end cap and the mullion and at the reglets.
 - Seal over all screw heads.
 - At the bottom of the mullions, apply sealant to the center cavity to a height of 1/2".
- See **Detail 15**.

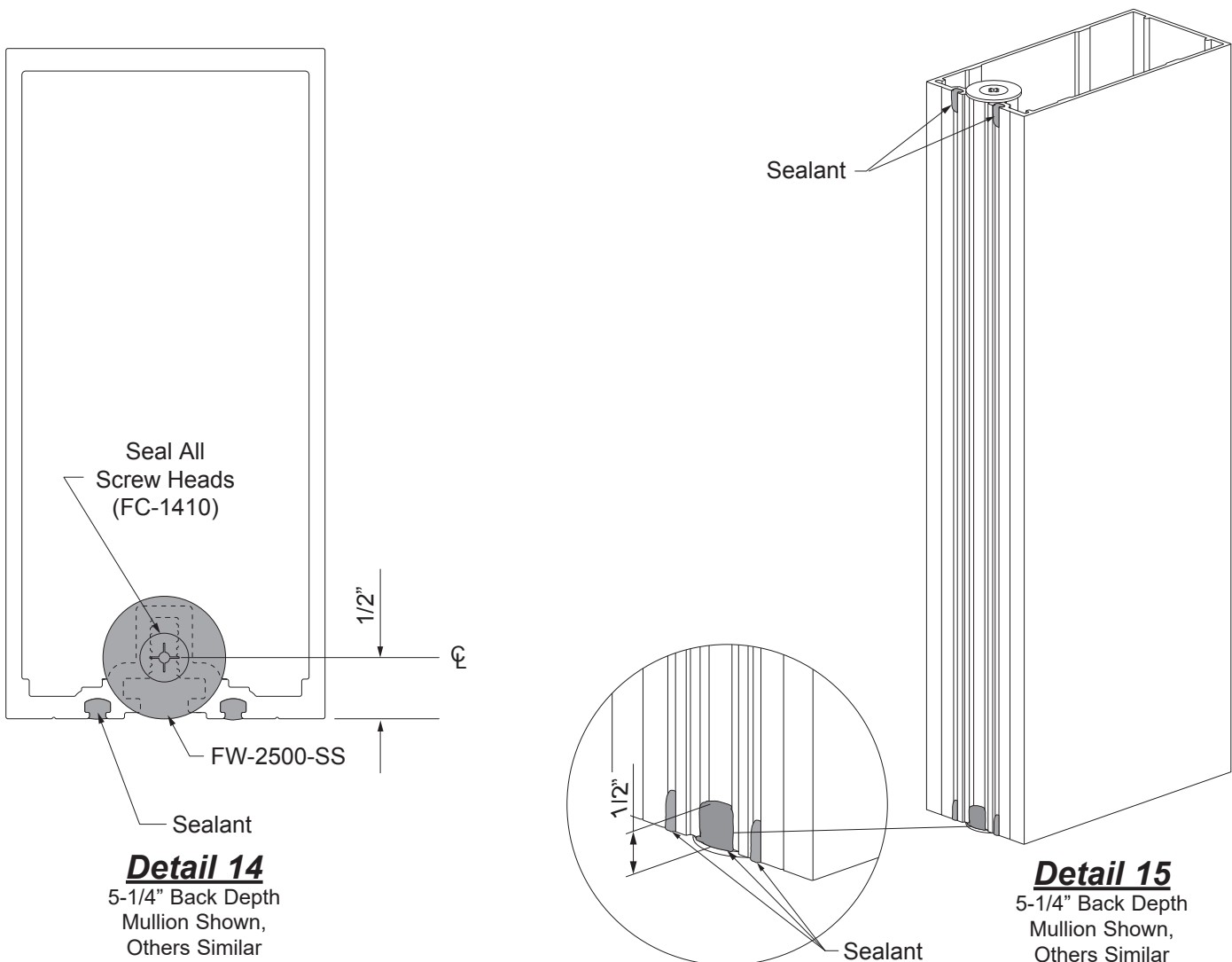

Detail 14

5-1/4" Back Depth Mullion Shown, Others Similar

Detail 15

5-1/4" Back Depth Mullion Shown, Others Similar

FRAME INSTALLATION

STEP 12 INSTALL JAMB & VERTICAL MULLIONS

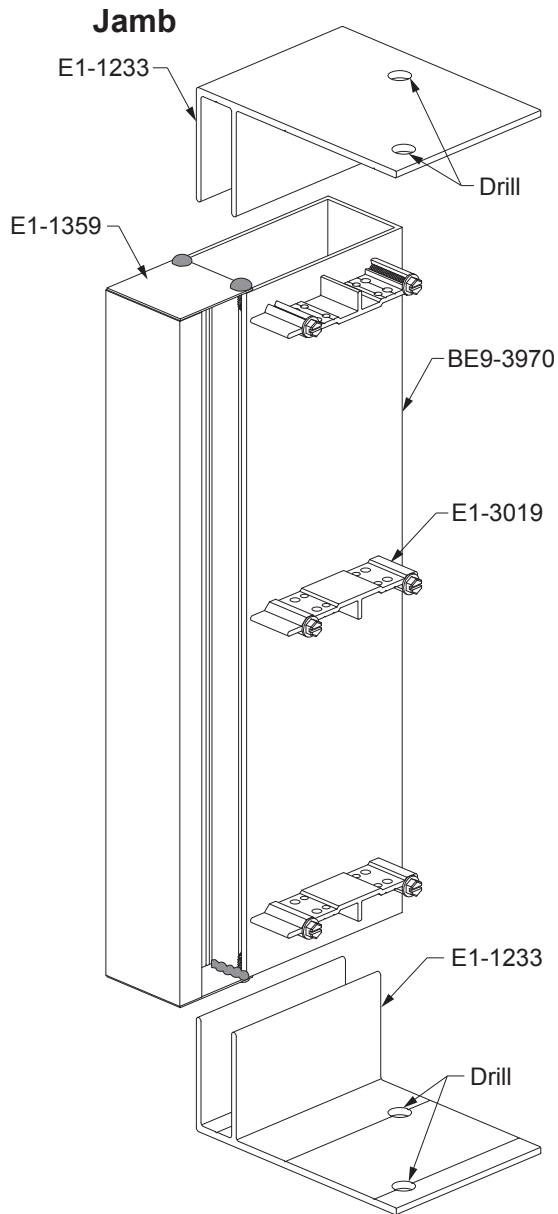

-Insert mullion “T” anchors, E1-1208 (5-1/4” back) or E1-1229 (3-3/4” back), and “F” anchors, E1-1233 (5-1/4” back) or E1-1230 (3-3/4” back), into the top and bottom of intermediate and jamb mullions before erecting the mullion into the opening.

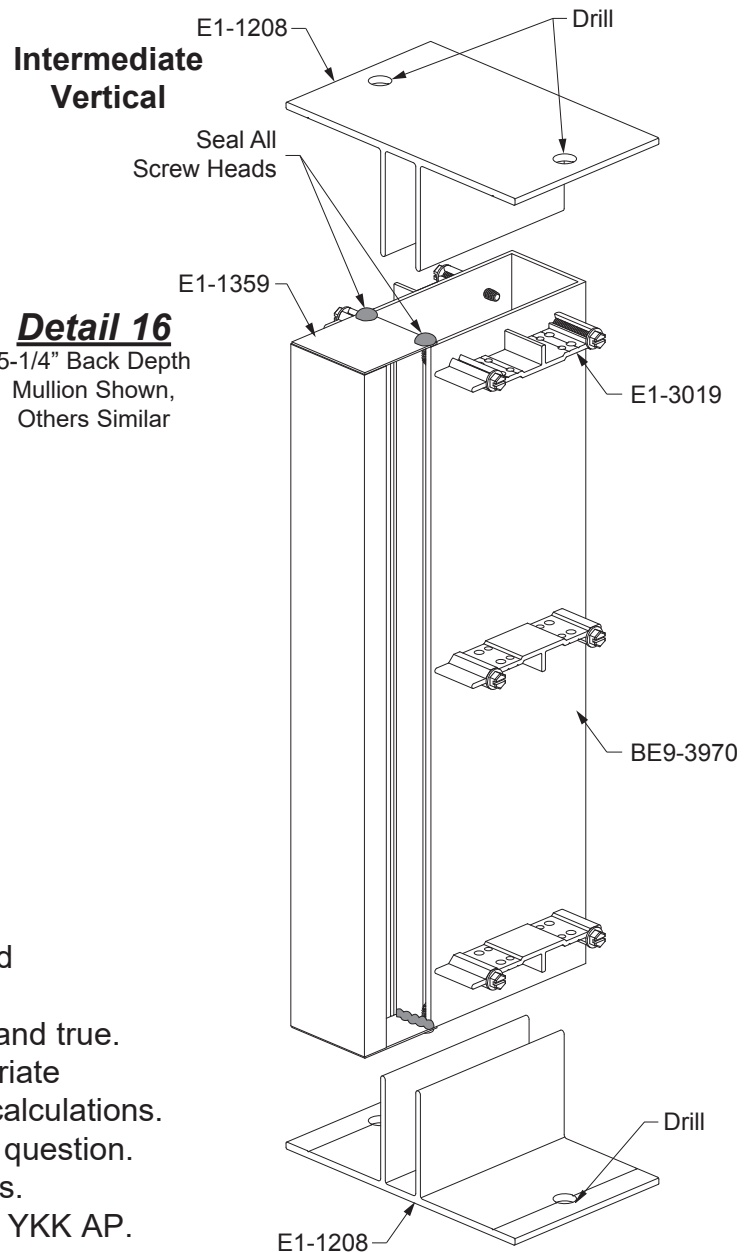

- Erect and locate the jambs and verticals and temporarily attach them to the structure.
- Note:** All mullions must be installed plumb and true.
- Drill holes in “T” and “F” anchors for appropriate anchor fasteners according to engineering calculations. Consult YKK AP if load requirements are in question.
- Install anchor fasteners per job requirements.
- Note:** Anchor fasteners are not supplied by YKK AP. See **Detail 16**.

FRAME INSTALLATION

STEP 12A VERTICAL INSTALLATION AT DOOR JAMB END ANCHORS

The mullions at the door jambs are set directly upon the sill substrate without any shims and are sealed against the substrate. The anchors to be used at this location are specified by the approved shop drawings and or P.E. calculations.

-Locate the mullion anchor for the door jamb and install it to the substrate according to the approved shop drawings and P.E. calculations.

-Clean all contact surfaces as recommended by sealant manufacturer.

-Set the mullion on the anchor, directly onto the sill substrate in a bed of sealant. Avoid using shims at this location.

See **Detail 17**.

-Refer to the approved shop drawings for any additional fasteners required.

-Tool sealant at the bottom of the mullion at the sill substrate around the perimeter of the mullion.

See **Detail 18**.

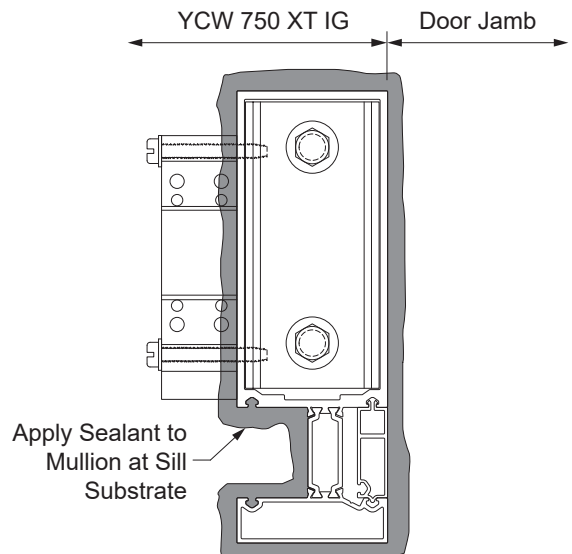
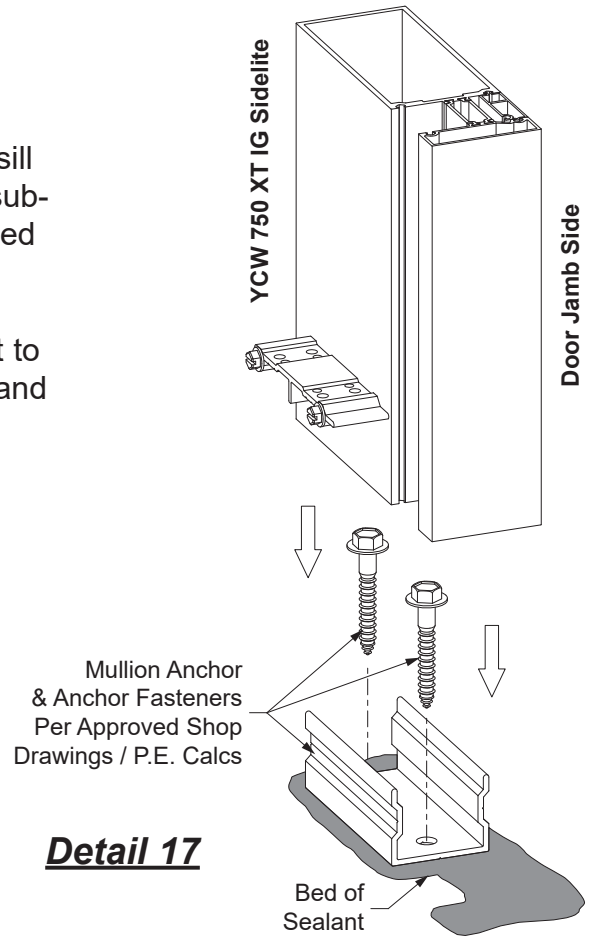

FRAME INSTALLATION

STEP 13 INSTALL WIND LOAD / DEAD LOAD ANCHORS

- Install steel mullion mid anchors:
Wind load anchor, E1-1204. See **Detail 19**.
Dead load anchor, E1-1205. See **Detail 20**.

Note: Required anchors and bolt size will vary based on project requirements. Consult a qualified engineer or YKK AP.

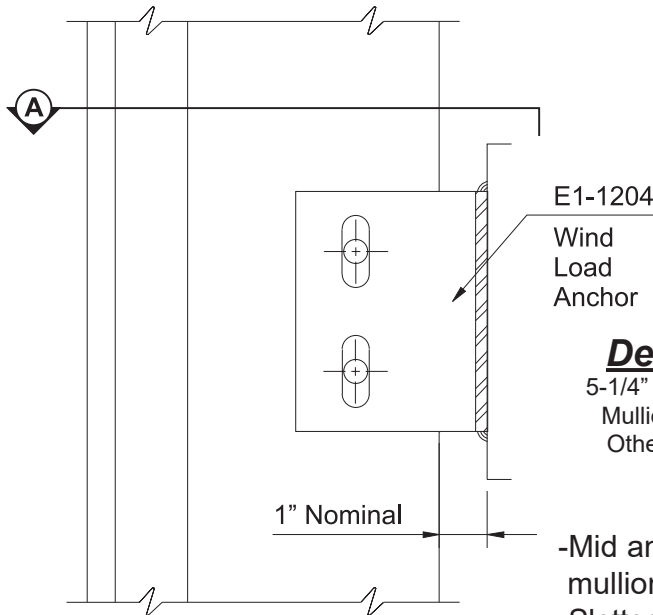

Detail 19
5-1/4" Back Depth Mullion Shown, Others Similar

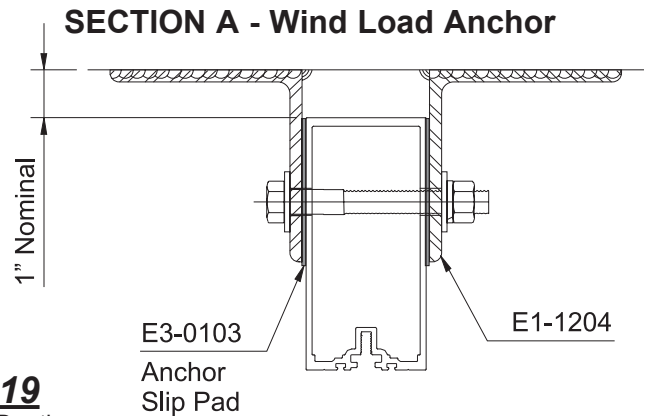

- Mid anchors are normally template or line set before mullions are hung.
- Slotted or drilled leg of clip must be set at 90° to offset leg. See shop drawings for details of mid anchor attachment.
- Install plumb and align vertical mullions, drill appropriate size holes for anchor bolts as shown in shop drawings.
- Anchor bolts are fastened **after** horizontals are attached.
- Nylon slip pads, E3-0103, **must** be installed between mullion and mid anchors.

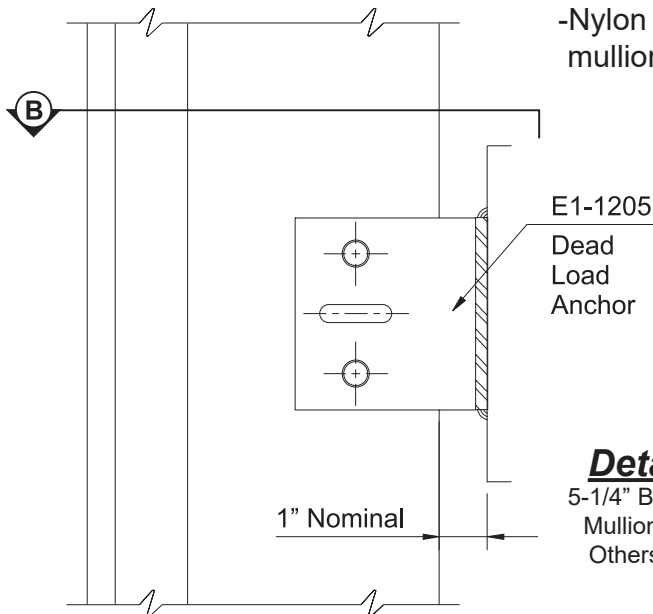

Detail 20
5-1/4" Back Depth Mullion Shown, Others Similar

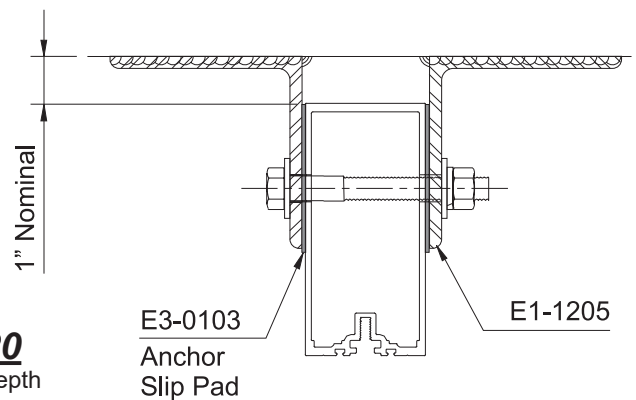

SECTION B - Dead Load Anchor

FRAME INSTALLATION

TYPICAL WIND LOAD ANCHOR

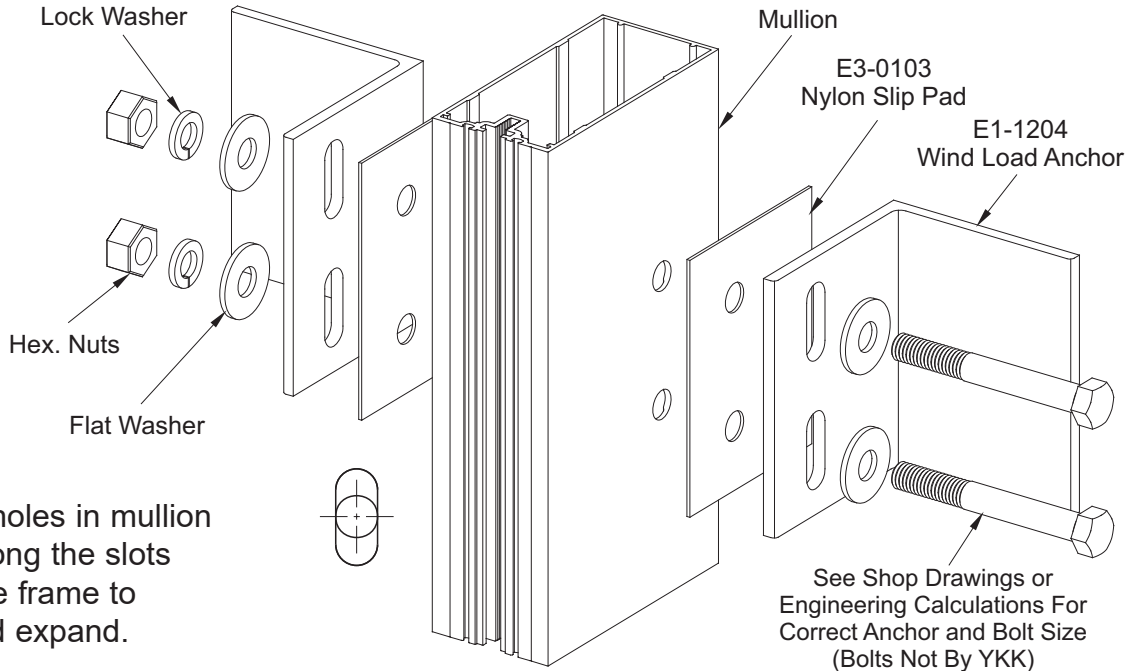

Note: Drill holes in mullion centered along the slots to permit the frame to contract and expand.

See Shop Drawings or Engineering Calculations For Correct Anchor and Bolt Size (Bolts Not By YKK)

Detail 21

TYPICAL DEAD LOAD ANCHOR

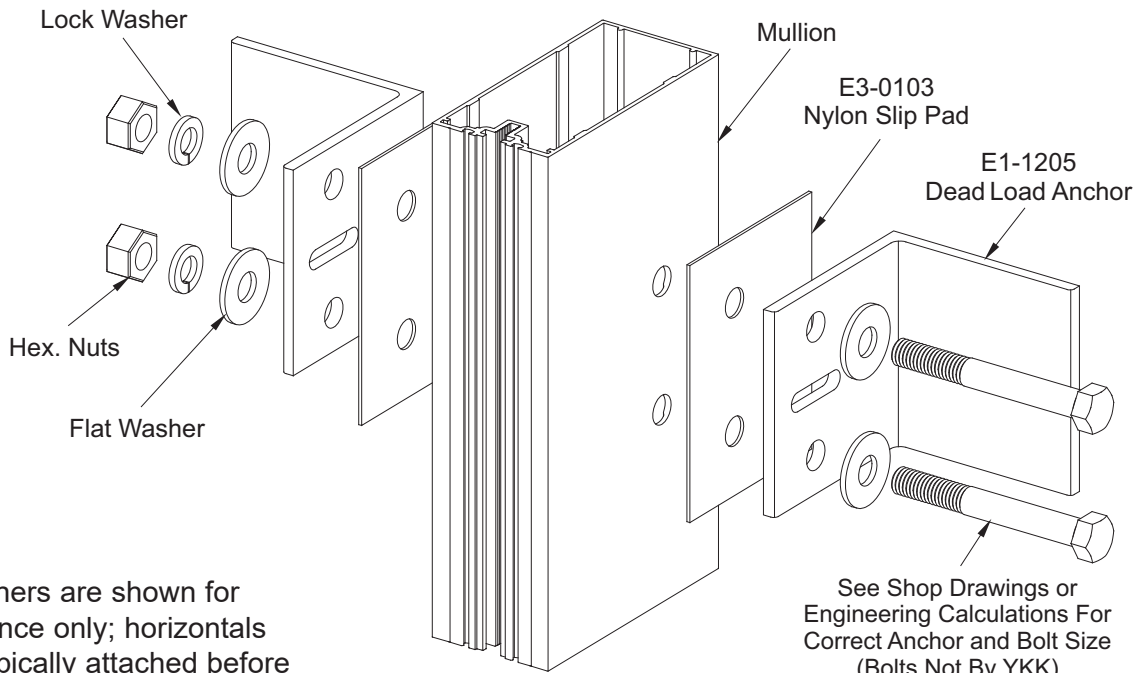

Note: Fasteners are shown for reference only; horizontals are typically attached before anchor fasteners are installed.

See Shop Drawings or Engineering Calculations For Correct Anchor and Bolt Size (Bolts Not By YKK)

FRAME INSTALLATION

JAMB WIND LOAD ANCHOR

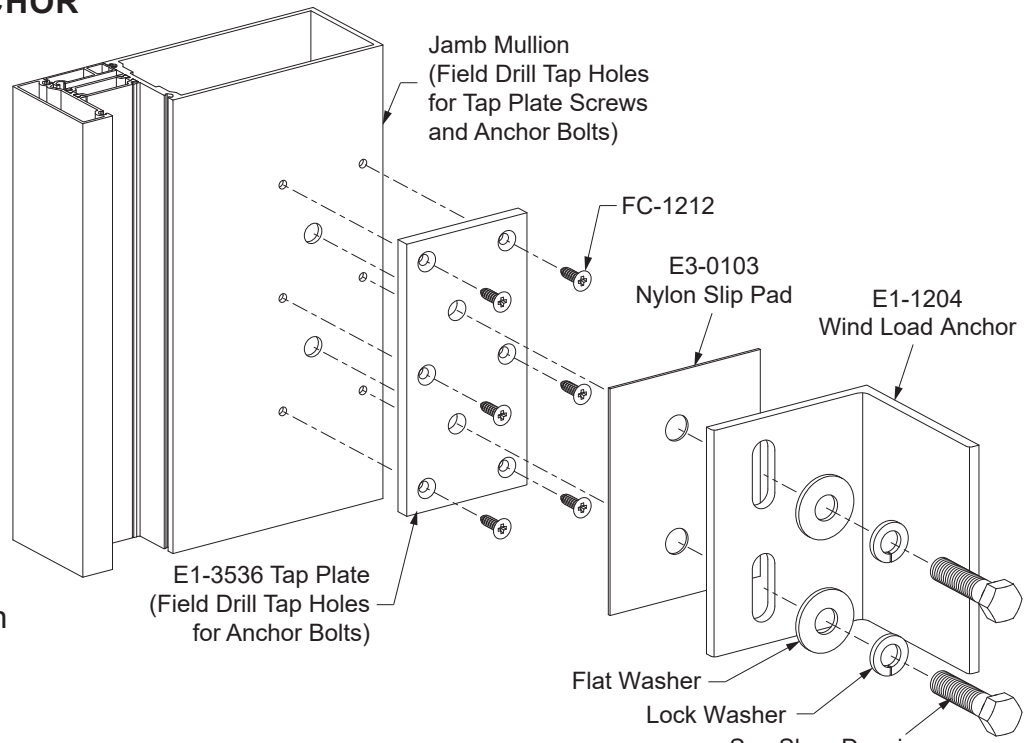

Note: Drill holes in mullion centered along the slots to permit the frame to contract and expand.

Detail 21A

See Shop Drawings or Engineering Calculations For Correct Bolt Size (Not By YKK AP)

JAMB DEAD LOAD ANCHOR

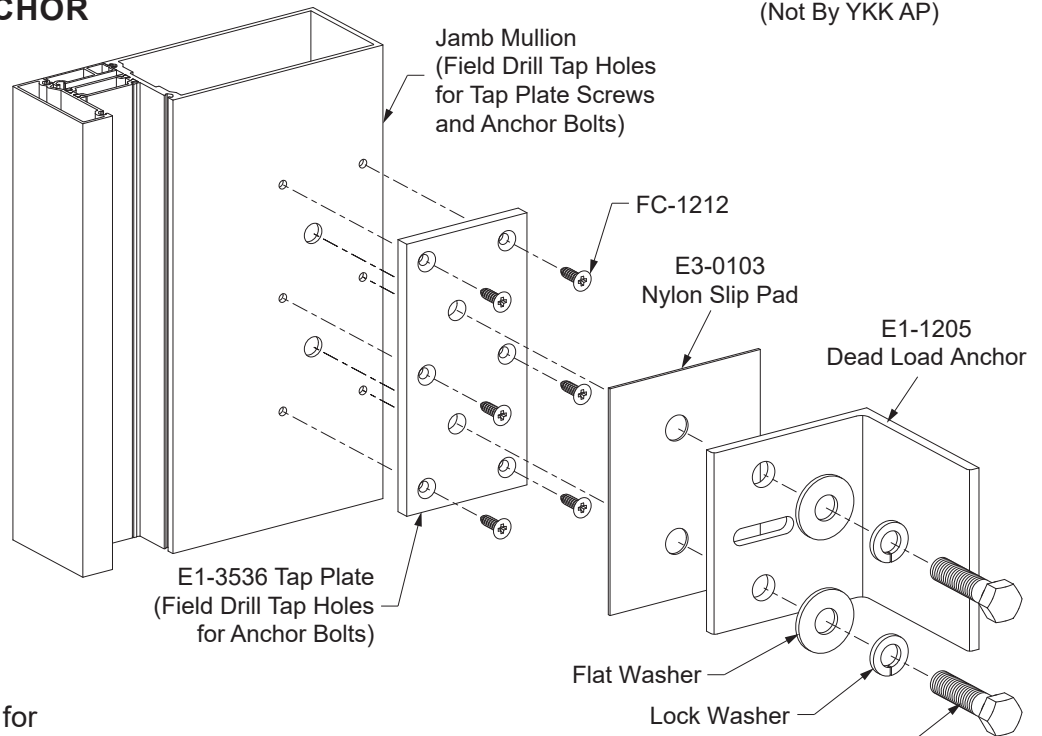

Note: Fasteners are shown for reference only; horizontals are typically attached before anchor fasteners are installed.

See Shop Drawings or Engineering Calculations For Correct Bolt Size (Not By YKK AP)

FRAME INSTALLATION

STEP 14 HEAD/HORIZONTAL/SILL ATTACHMENT

- Clean all contact surfaces with cleaner and method approved by sealant manufacturer.
 - Apply silicone to the ends of the horizontals as shown in **Detail 22** before attaching to the shear clips.
 - Just prior to attaching the horizontals, apply sealant to the front of the shear clips as shown in **Detail 23**.
 - Attach the head, intermediate horizontal, and sill to the shear clips with two PC-1208 fasteners at each end.
 - Tool and wipe away any excess sealant.
- See **Detail 23**.

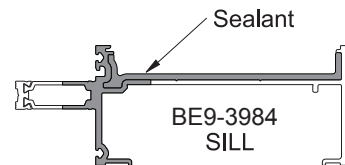
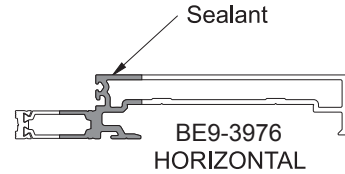
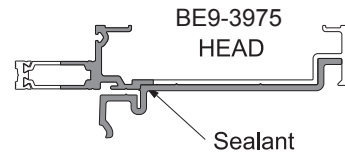

Detail 22

5-1/4" Back Depth
Mullion Shown,
Others Similar

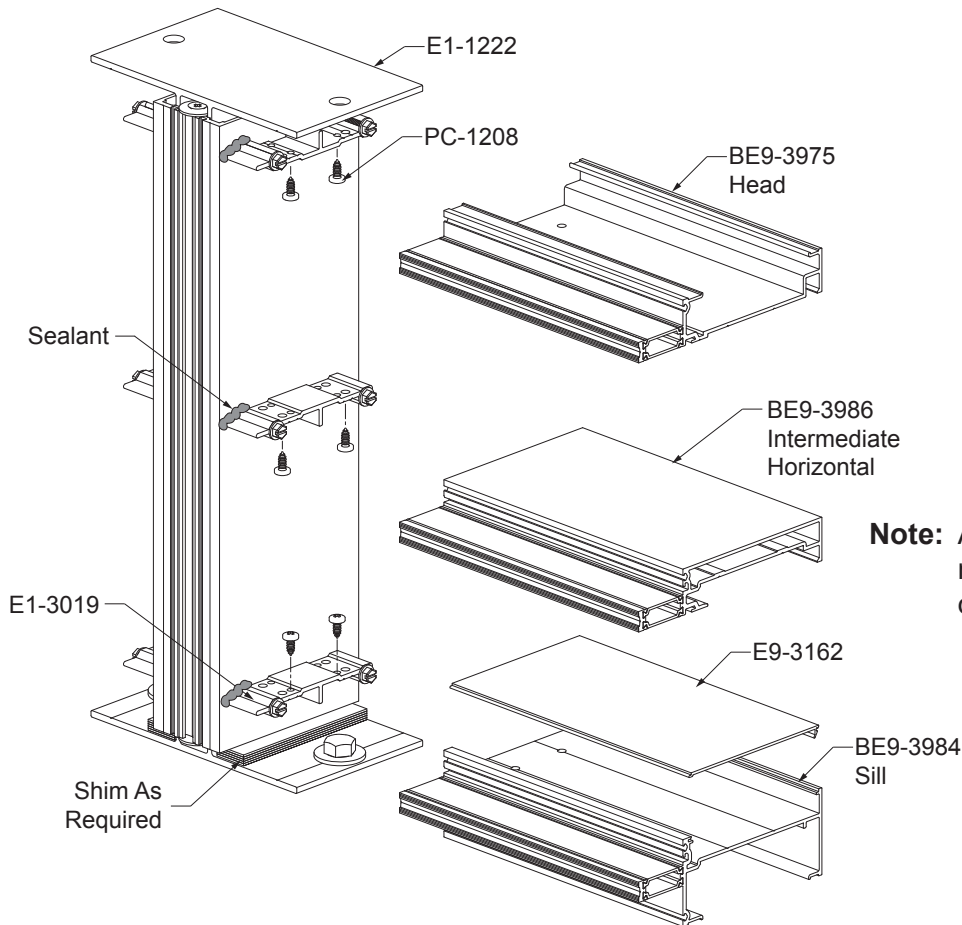

Note: Always shim underneath the mullion to transfer glazing dead loads to the foundation.

Detail 23

5-1/4" Back Depth
Mullion Shown,
Others Similar

FRAME INSTALLATION

STEP 15 INSTALL DOOR SUBFRAMES

Doors are shipped assembled, and door sub-frames will be fabricated and shipped knocked down. Refer to the **Entrances Installation Manual** for assembly of the door subframes. These subframes are installed into the curtain wall framing members and set directly upon the floor substrate. The subframe members are determined by the approved shop drawings.

-Clean all sealant contact surfaces as recommended by the sealant manufacturer.

Do not fasten the BE9-1532 transom bar into the curtain wall horizontal. The transom bar will be fastened into door jamb sub-frame with PC-1220 screws. See **Detail 25**.

-Install the jamb subframe onto the mullion with fasteners according to the approved shop drawings and/or P.E. calculations, setting the subframe jambs in beds of sealant as shown in **Detail 24**.

-Apply and tool sealant to the bottom of the jamb subframe as shown in **Detail 26**.

-Install door stop into the door jamb subframe.

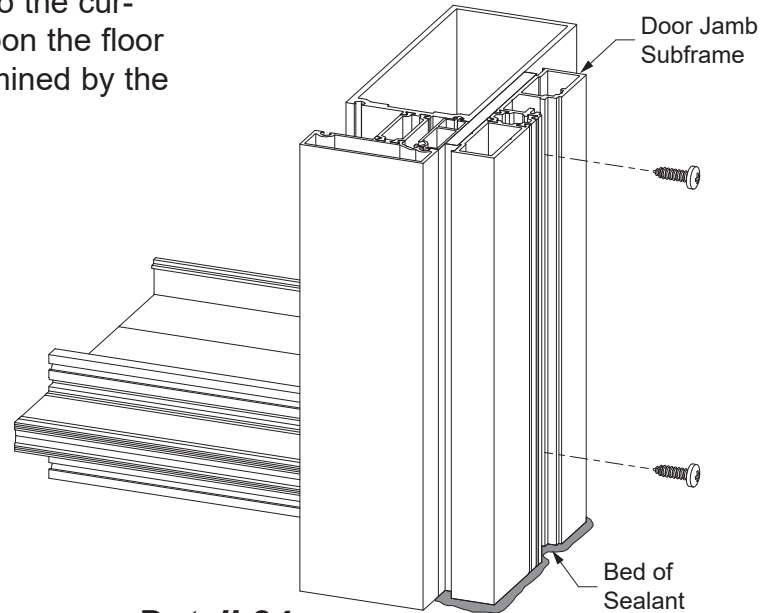

Detail 24

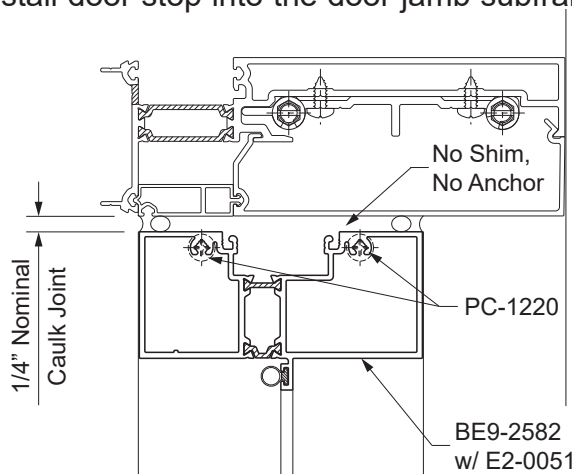

Detail 25

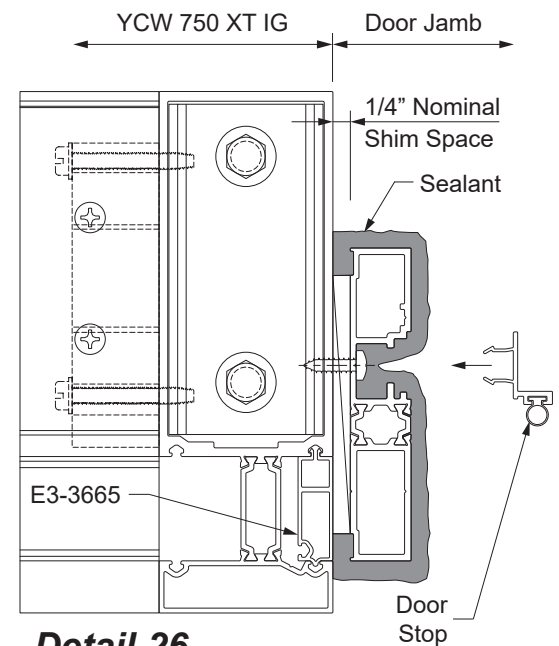

Detail 26

FRAME INSTALLATION

STEP 16

90° OUTSIDE CORNER ASSEMBLY

- Locate both mullions perpendicular to each other as shown in **Detail 27**.
- Anchor vertical ends with appropriate end anchors. Refer to shop drawings for mid anchors.
- Insert glazing pocket filler, E3-3665, into the shallow pocket of the corner mullions.
- Position angle E9-9303 into corner between the two mullions and fasten both legs every 18" o.c. and 3" from each end using PC-1010 fasteners.
- Apply a 3" bead of sealant to the inside leg of angle E9-9302 at each end and position angle E9-9302 flush with the face of the verticals and fasten to the verticals every 18" o.c. and 3" from each end using PC-1010 fasteners.
- Position the formed aluminum cover into place and fasten with PC-1010 fasteners every 18" o.c. and 3" from each end.
- Do not span formed aluminum cover more than 12'-6"; leave 1/2" joint between spans of 12'-6".
- Clean area around joint using cleaner and method approved by sealant manufacturer. Priming may be required for certain finishes.
- Compress backer rod into the 1/2" joint. Apply and tool sealant to the joint.

See **Detail 27**.

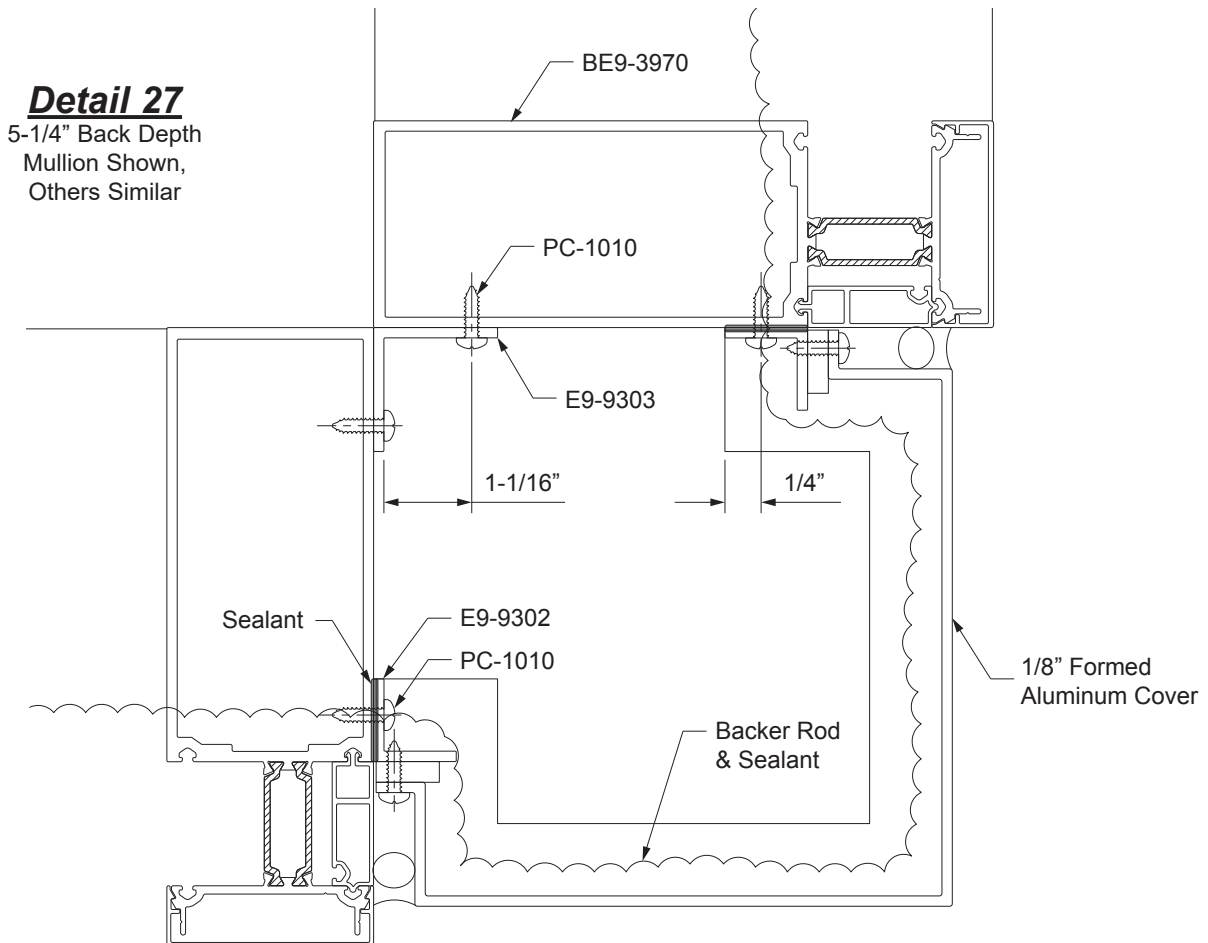

FRAME INSTALLATION

STEP 17

APPLY PERIMETER SEALANT

- Position backer rod around perimeter of frame.
- Clean around the perimeter of the frame with cleaner and method approved by sealant manufacturer.
- Apply and tool sealant to the perimeter of the frame. Make sure sealant does not contact the thermal isolator clips or extrusion leg.
- Wipe off any excess sealant immediately.

See **Detail 28**.

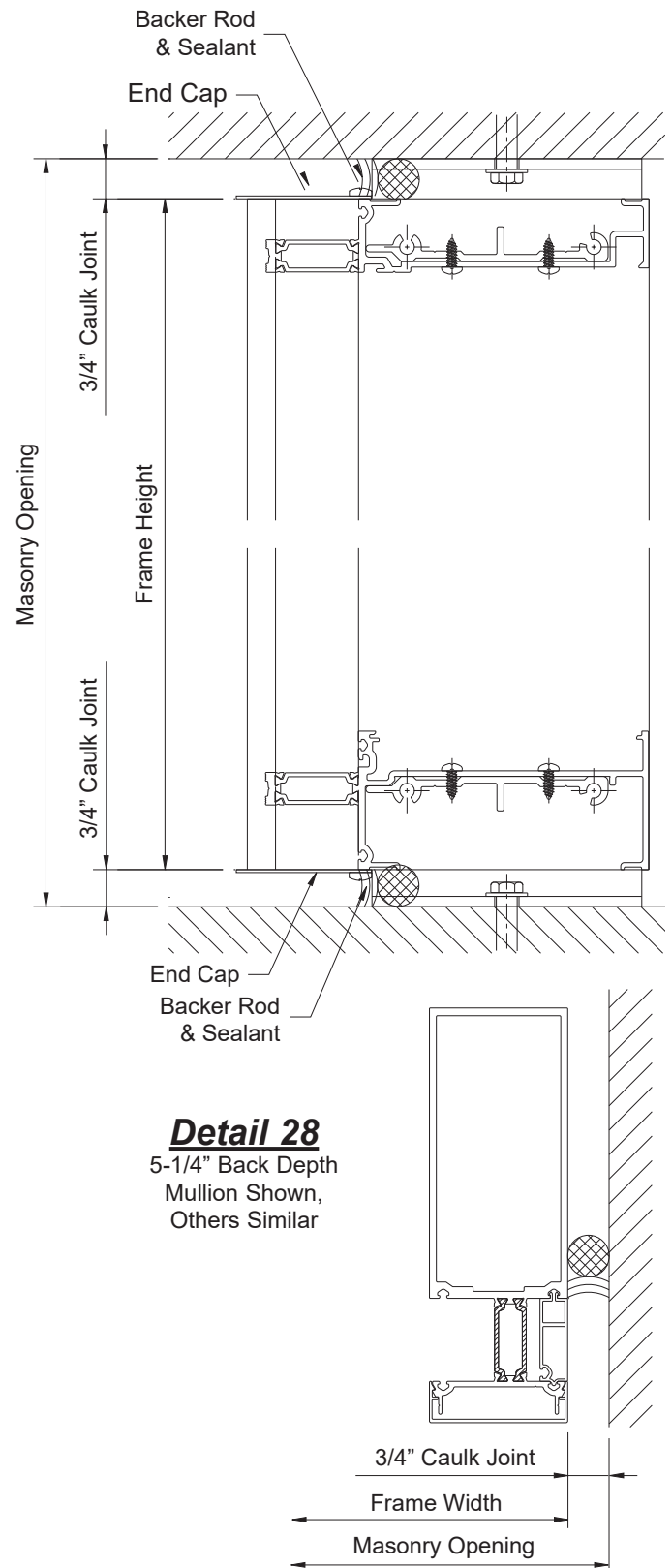

GLAZING

**STEP 18
INSTALL JOINT PLUGS**

-The opening where the horizontal glazing pocket meets the vertical glazing pocket must be plugged and sealed with joint plugs, at all intersections including head and sill:
E2-3663 for 1" glazing

Note: Clean all contact surfaces with cleaner and method approved by sealant manufacturer.

See **Detail 30**.

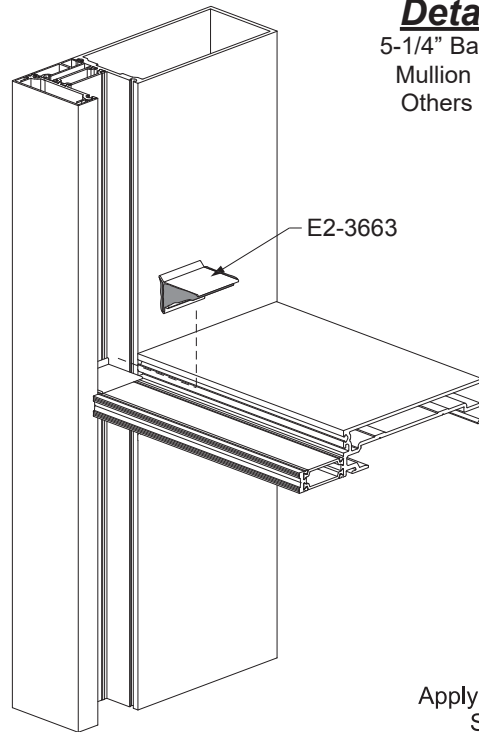

Detail 30
5-1/4" Back Depth
Mullion Shown,
Others Similar

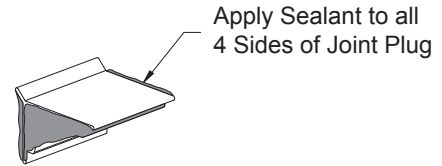

- Apply silicone sealant to all four contact sides of the joint plug.
- Install the joint plug into the cavity. Press down until the bottom lip of the joint plug touches the horizontal.
- Apply and tool sealant to completely cover the top of the joint plug.
- Tool the excess sealant along the edges of the joint plug to seal the cavity.

-Apply sealant to vertical and horizontal joints.
-Tool the sealant where the face of the horizontal meets the mullion down to the end dam.
-Tool the sealant where the pressure plate meets the mullion face cover to complete the seal at this joint.
See **Detail 31**.

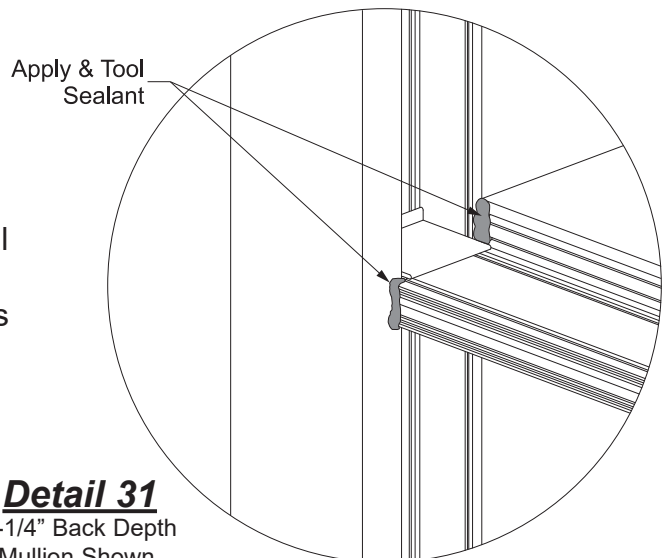

Detail 31
5-1/4" Back Depth
Mullion Shown,
Others Similar

GLAZING

STEP 18 (Continued) INSTALL JOINT PLUGS (for SSG Mullion)

- For SSG mullions, use the E2-3615 joint plug between the IG horizontal members.
- Apply silicone to the three contact sides of the joint plug.
- Install the joint plug into the glazing pocket cavity at the SSG mullion. Apply and tool sealant to completely cover the top of the joint plug.
- Tool the excess sealant along the edges of the joint plug to seal the cavity, including the cavity at the SSG mullion behind the joint plug.

Note: In the case where the pressure plate is pre-installed before erection, the joint plug can be installed by pushing it in from above.

See **Detail 32**.

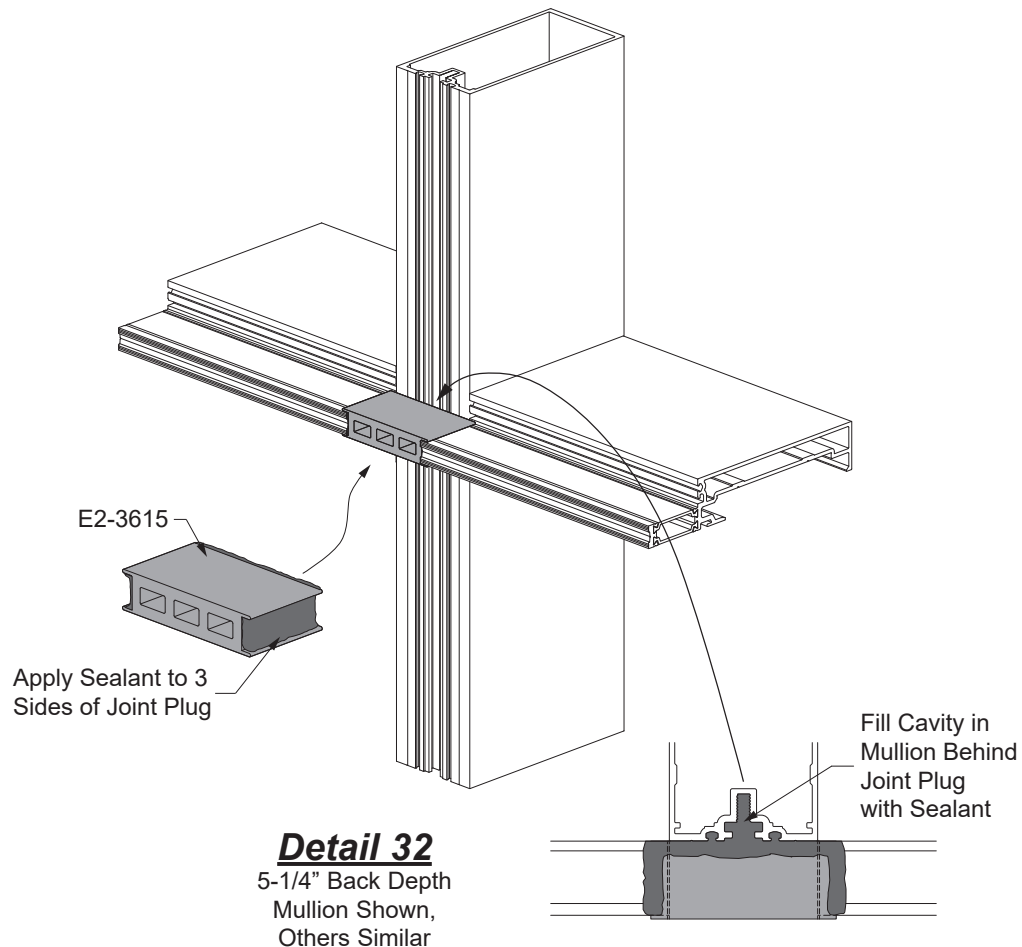

GLAZING

**STEP 19
INSTALL PRESSURE PLATES & SETTING BLOCKS**

-Horizontal exterior gaskets are to be cut to length of the pressure plate.

-Apply E2-0356 tape to pressure plates

See **Detail 33**.

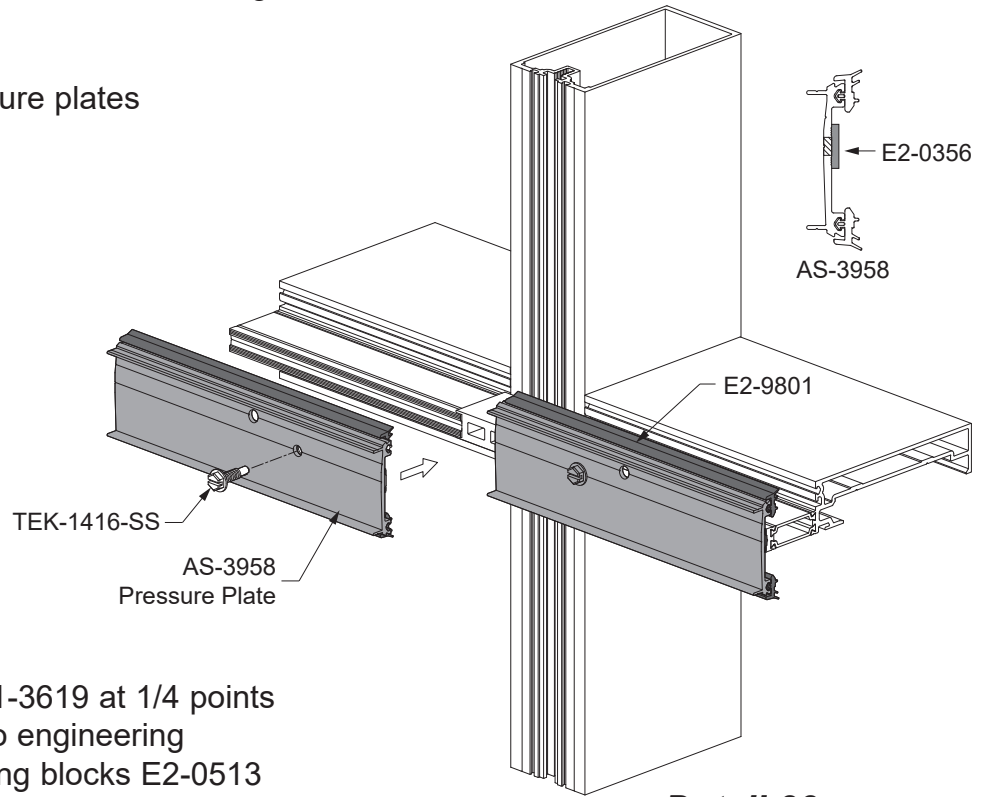

Detail 33

-Install setting block chairs E1-3619 at 1/4 points of the D.L.O. (or according to engineering calculations), and place setting blocks E2-0513 on the chairs.

See **Detail 34**.

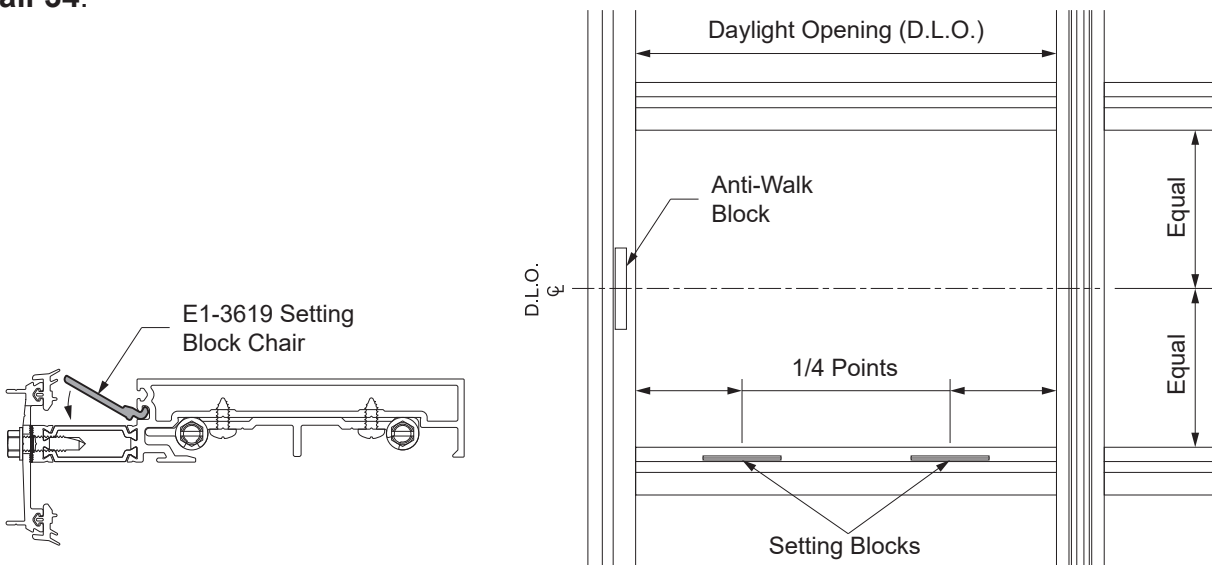

Detail 34

GLAZING

STEP 20 INSTALL EXTERIOR GASKETS

- Cut vertical exterior gaskets to daylight opening plus(+) 1-1/2”.
- Notch 9/16” off the leg at each end of the vertical exterior gaskets.
- Cut horizontal exterior gaskets to the length of the pressure plates.
- Apply sealant in vertical gasket reglets from the gasket corner 3” out in both directions.
- Install the vertical exterior gaskets first, centered along the vertical daylight opening.
- Install the horizontal exterior gaskets.
 - Apply sealant to each end of the horizontal gasket.
 - Insert the gasket into the reglet at each end first and push each end tight against the vertical gasket. Then insert the gasket at the midpoint of the opening and push the gasket into the reglet starting at the midpoint and work towards each end.
- Tool the sealant where the end of the horizontal gasket meets the vertical gasket.

See **Detail 35**.

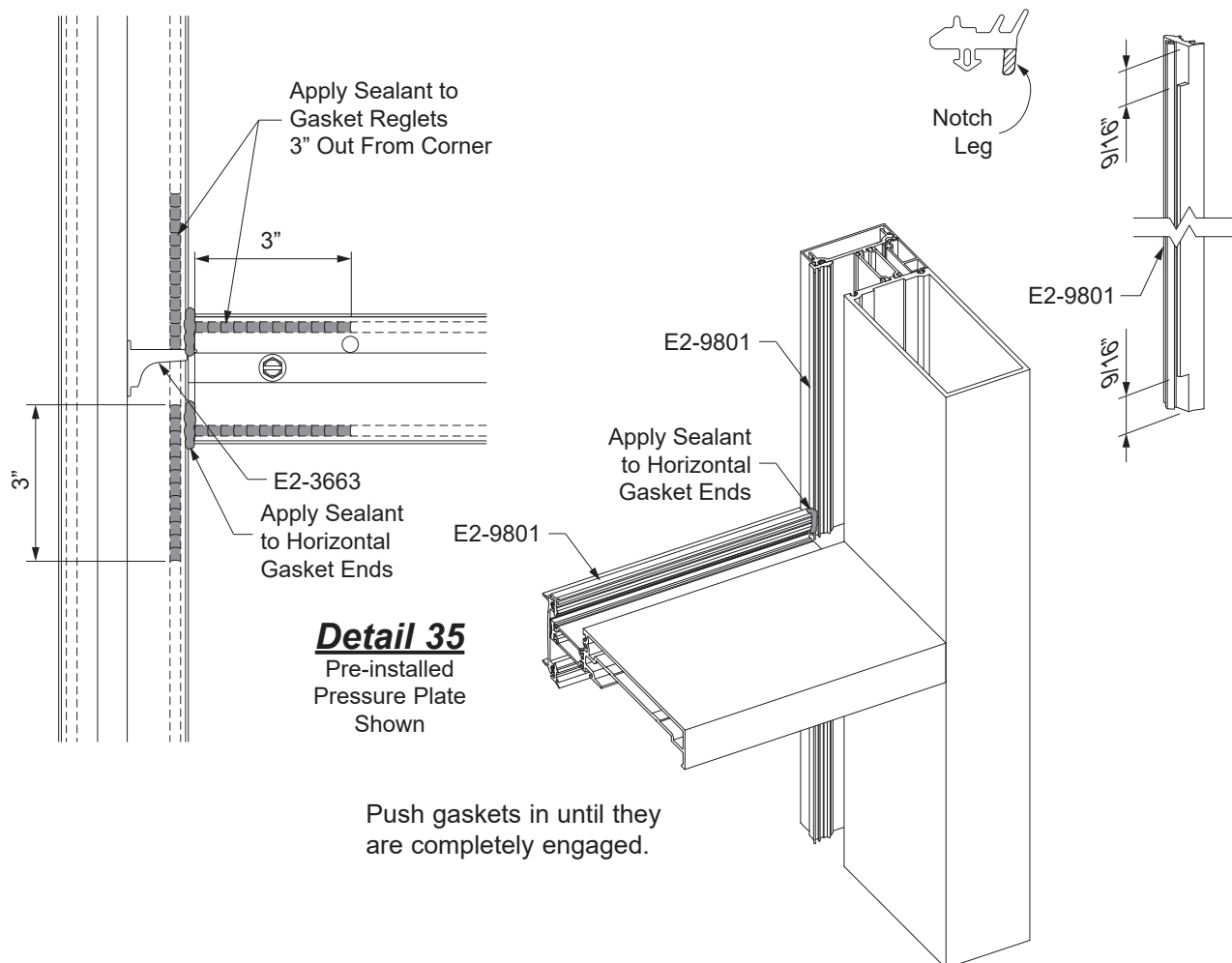

GLAZING

STEP 21 PRESSURE PLATE LAYOUT AND ASSEMBLY

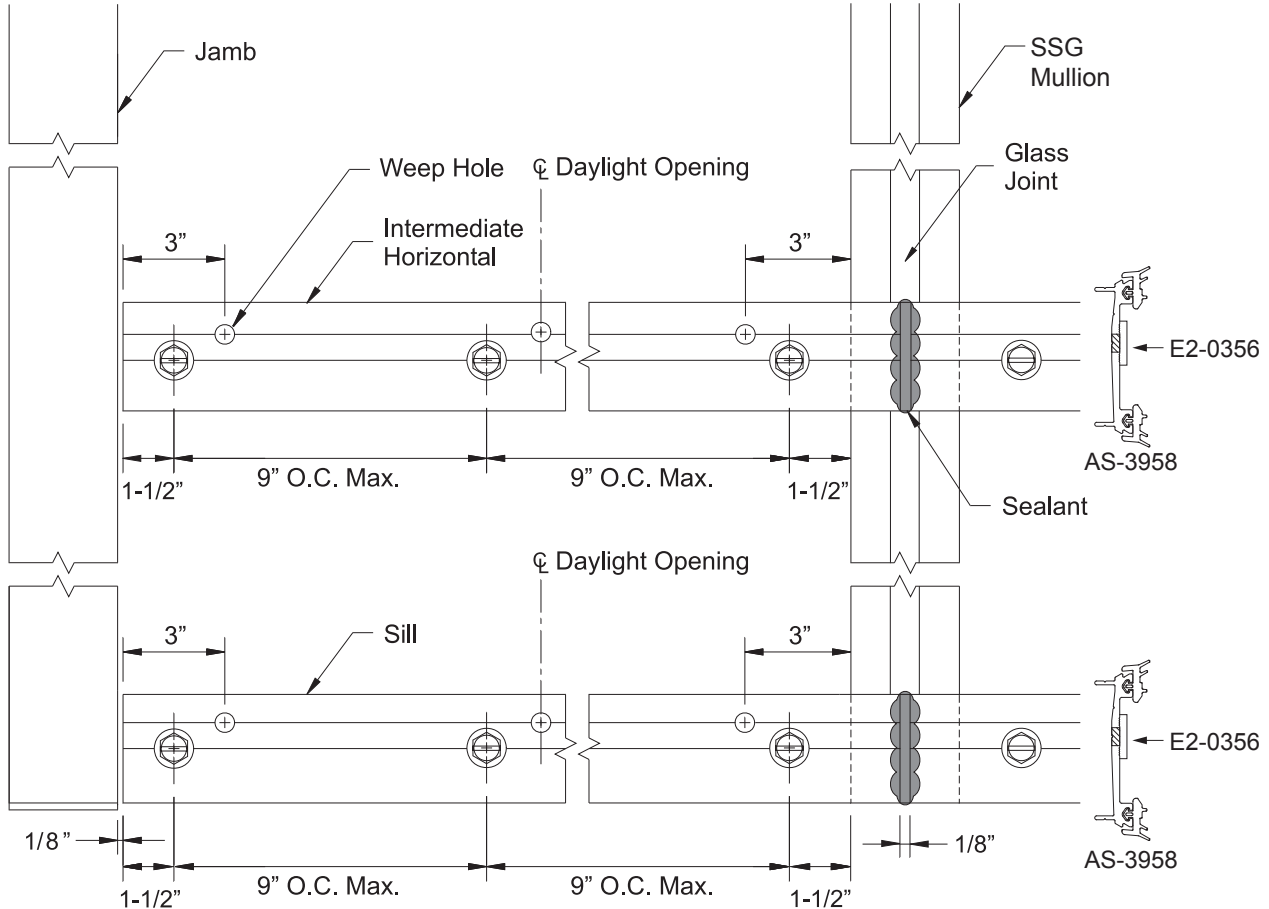

Detail 36

- Pressure plate stock lengths are factory punched with 0.281" diameter holes at 9" o.c. maximum. After cutting, additional holes may be required to have fasteners 1-1/2" from each end.
- Install isolator tape, E2-0356, onto the pressure plates as shown in **Detail 36**.
- Install pressure plates using TEK-1416 screws. Initially torque fasteners to 30-inch pounds with a speed wrench or torque limiting screw gun. Work from the bottom up.
- Center and install horizontal pressure plates in opening, leaving gaps at the ends as shown.
- Starting at the center of each pressure plate, tighten each fastener to 50-inch pounds.
- Apply and tool sealant to completely seal gaps at the pressure plate ends.
- Torque all vertical pressure plate fasteners to 50-inch pounds.

See **Detail 36**.

GLAZING

STEP 22 INSTALL GLASS (TYPICAL)

- Clean all glazing surfaces and joints of foreign matter and contaminants such as grease, oil, dust, frost, and dirt. Do not use water or soap to clean surfaces or to tool sealant.
- Carefully install glass into the frame. See **Detail 37** for glass sizes. Coming from the interior, insert the glass lite in front of the SSG mullion first, and then swing the other end past the vertical to where it can be lowered onto the setting blocks.

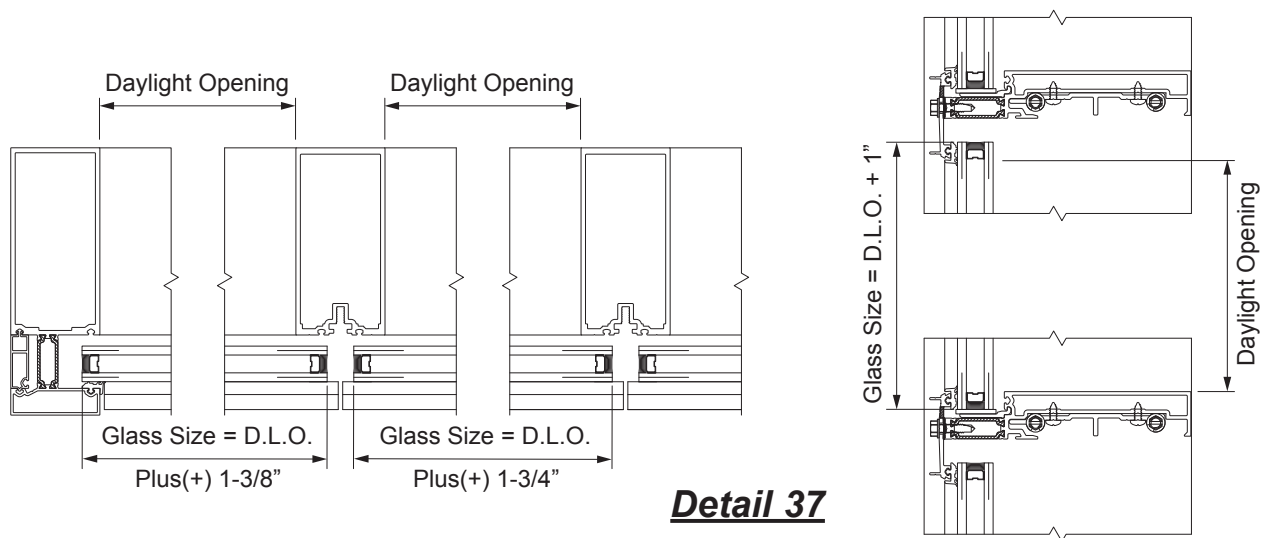

Detail 37

- Final alignment of the glass will leave a 3/4" wide gap between the glass lites, centered at the SSG mullion. However, in order to make it possible to glaze this SSG system from the inside, it may be necessary to temporarily alter the position of the glass lites until all are installed. Then reposition the glass lites to their proper locations, providing a 3/4" gap at the SSG mullions.

- Secure glass with SSG temporary glass retainers (E3-0001) every 3'-0" maximum along the SSG verticals.

See **Detail 37**.

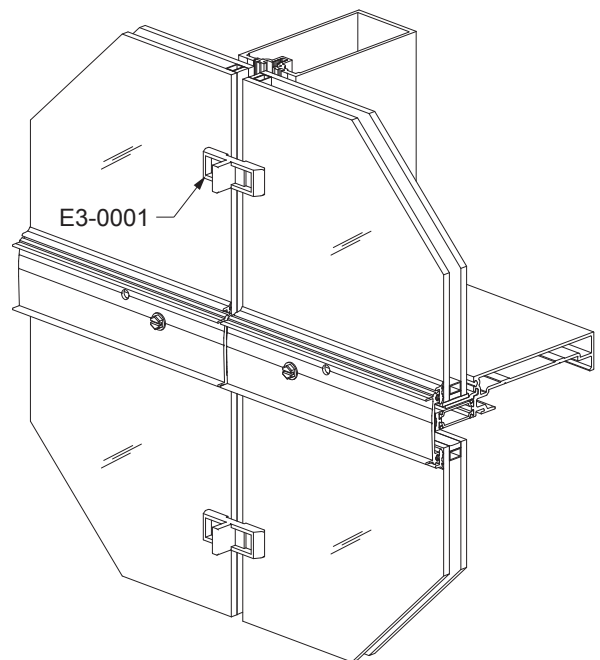

GLAZING

**STEP 22 (Continued)
POSITION GLASS AT JAMB**

-Push the glass against the exterior gaskets, and install small pieces of E2-9914 (cut down 2 to 3 inches) along the vertical to temporarily hold the glass in place.

See **Detail 38**.

-Apply sealant to the ends of the horizontal glass stops, E9-3968 for 1" glass.
-Install the horizontal glass stops.
-Apply and tool sealant behind the glass stop to create a watertight seal.

See **Detail 39**.

Detail 38

5-1/4" Back Depth
Mullion Shown,
Others Similar

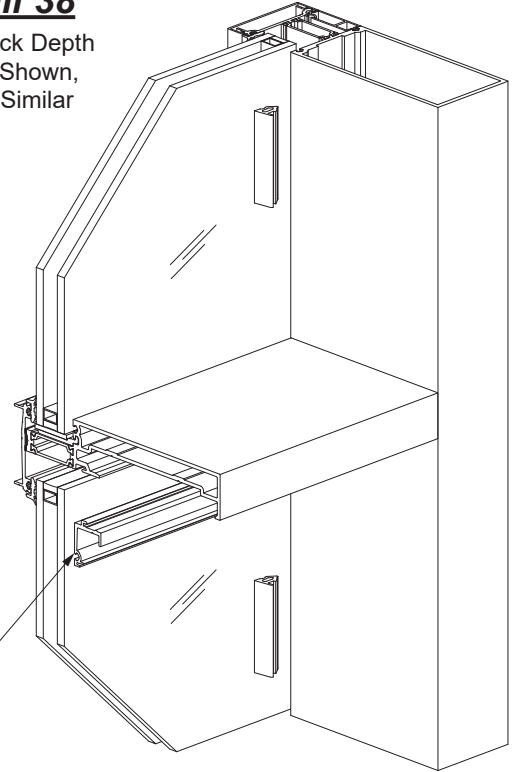

Detail 39

5-1/4" Back Depth
1" Glazing Shown
Others Similar

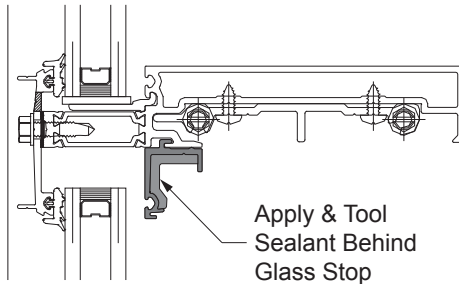

-Install one anti-walk block, E2-0546, in the deep glazing pocket of each jamb mullion, centered along the vertical daylight opening.
-Flatten the anti-walk block against the inside surface of the glass and push it into the opening between the glass and the mullion until it is released into the glazing pocket.

See **Detail 40**.

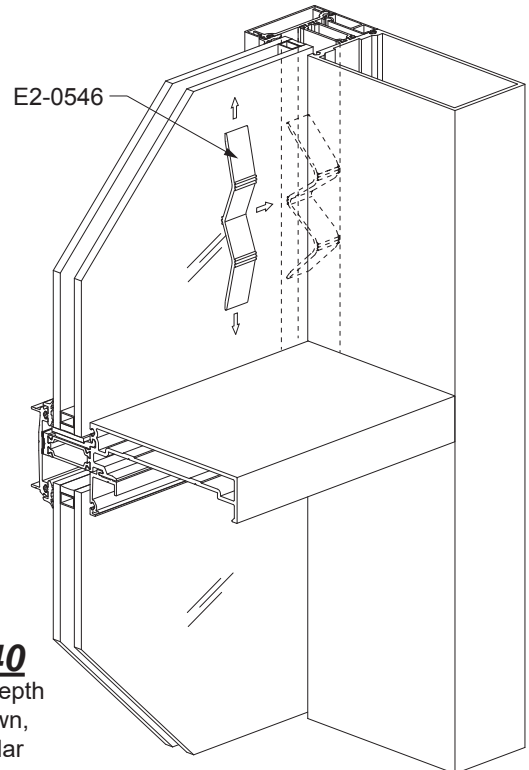

Detail 40

5-1/4" Back Depth
Mullion Shown,
Others Similar

GLAZING

STEP 23 INSTALL INTERIOR GASKETS FOR SSG MULLIONS

- The vertical SSG spacers are to be installed first. Cut the E2-0535 SSG spacer to daylight opening plus (+) 1-1/2". Insert the ssg spacer by pushing it into the glazing pocket to a depth of 1/2" from the edge of the mullion as shown in **Detail 41**.
- The E2-9914 horizontal interior gaskets are to be cut to daylight opening plus (+) 1", plus (+) 1/4" for each foot of daylight opening length. The ends of the gaskets will have to be notched by 1/2" to clear the edge of the ssg mullion.
- Apply sealant to the ends of the E9-3968 glass stop and insert the glass stop to the underside of the horizontal as previously shown in **Detail 39** on **Page 36**.
- Apply sealant to the each end of the horizontal gasket.
- Insert the gasket into the reglet at each end, pushing each end tightly against the ssg mullion.
- Then insert the gasket at the midpoint of the opening and push the remainder of the gasket in, working from the midpoint to the ends.

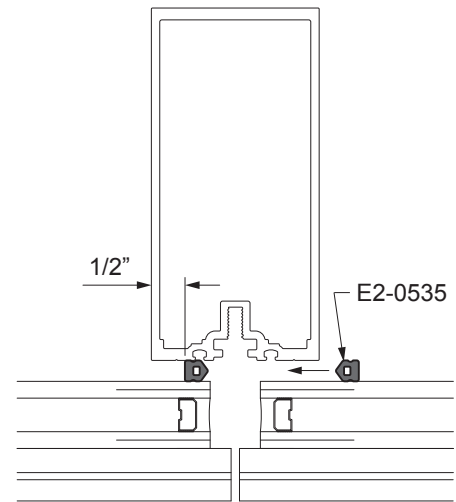

Detail 41

See **Detail 42**.

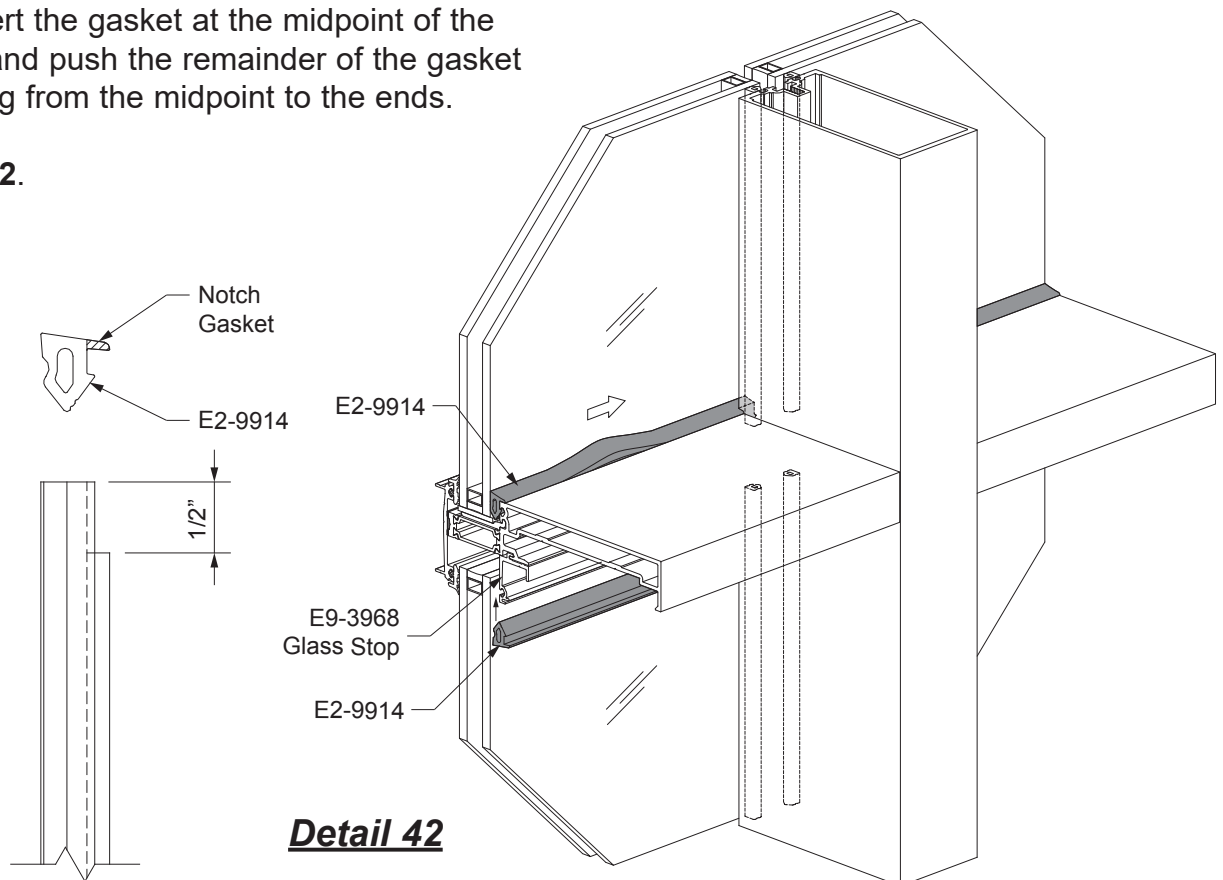

Detail 42

GLAZING

STEP 23 (Continued)

INSTALL INTERIOR GASKETS AT JAMB

- Cut horizontal & vertical interior gaskets to daylight opening plus(+) 1/2", plus(+) 1/4" for each foot of daylight opening length.
- Install the vertical interior gaskets first.
 - Insert each end and the midpoint of the gasket into the reglet.
 - Push in the remainder of the gasket working in from the midpoint to the ends.
- Install the horizontal interior gaskets next.
 - The end going into the ssg mullion (not shown) is to be notched by 1/2" as shown in **Detail 42 on Page 37**.
 - Apply sealant to the each end of the horizontal gasket.
 - Insert the gasket into the reglet at each end, pushing the notched end tightly into the ssg mullion and the other end tightly against the jamb mullion.
 - Then insert the gasket at the midpoint of the opening and push the remainder of the gasket in working from the midpoint to the ends.
 - Tool the sealant where the end of the horizontal gasket meets the vertical gasket.

See **Detail 43**.

Detail 43

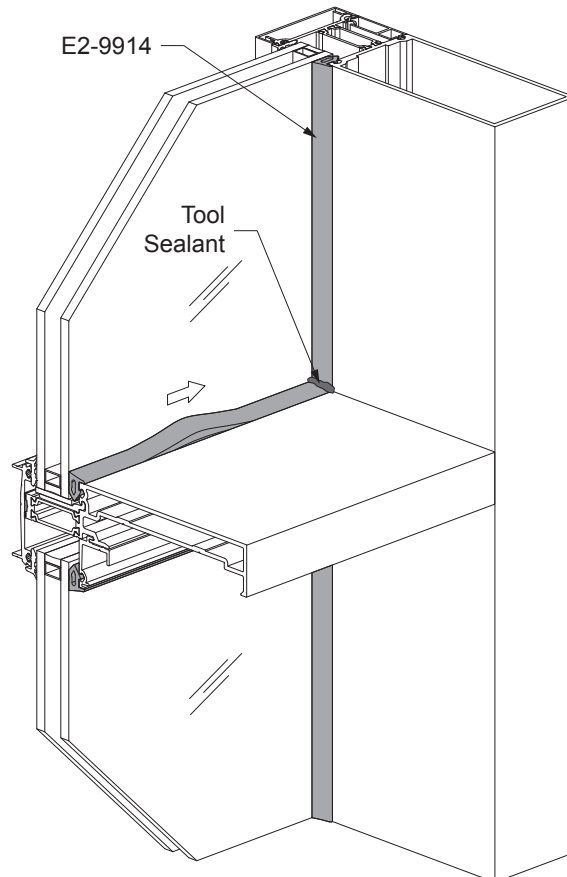

GLAZING

STEP 24 INSTALL INTERIOR COVERS

-Snap on the interior covers on the underside of the horizontals by inserting the front edge of the cover into the recess at the bottom of the glass stop and rolling it up to the snap onto the back of the head or horizontal.

Note: Horizontals not located in vision areas do not need interior covers.

See **Detail 44**.

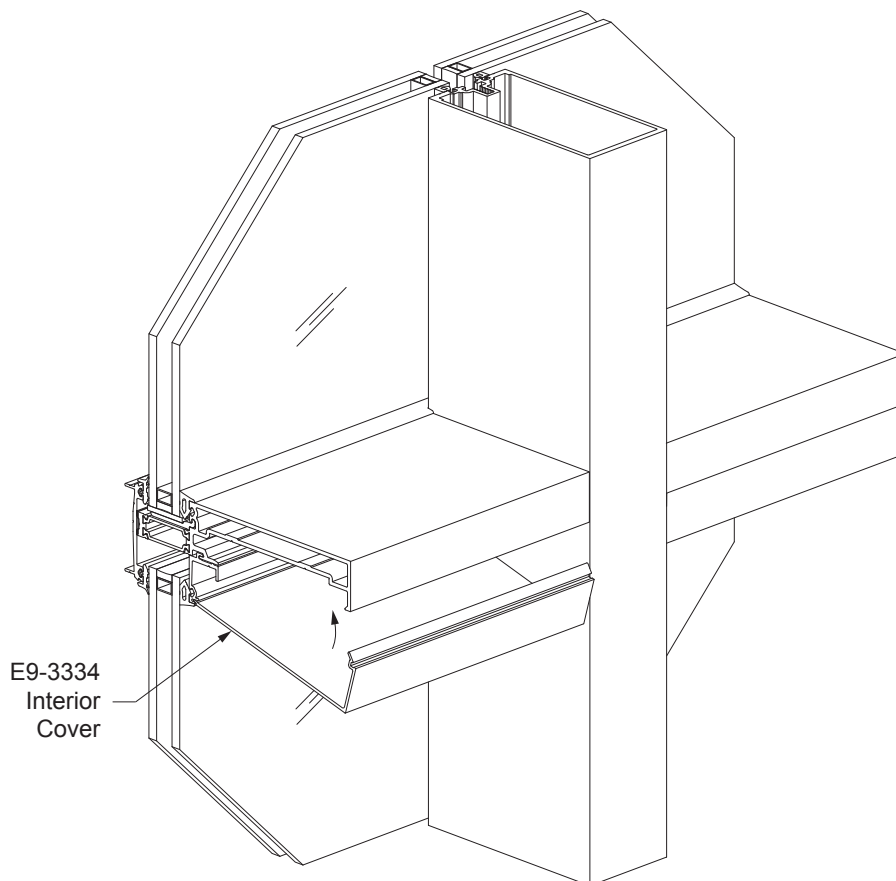

Detail 44

GLAZING

STEP 25

APPLY INTERIOR SEALANT TO SSG MULLIONS

- Ensure that all silicone contact surfaces and joints have been cleaned with a cleaner and method as approved by sealant manufacturer.
- Apply masking tape to both the glass and each side of the ssg mullion at the glazing cavity as shown in **Detail 45**.
- Apply tested structural silicone sealant into the cavity between the mullion and the glass from the bottom and work towards the top. Use positive pressure so that the silicone sealant completely fills the cavity.
- Using a nylon spatula or other non-scratching implement, tool the silicone sealant immediately after running the joint. Exert positive pressure while tooling to ensure that the silicone sealant makes complete contact with all surfaces. Be careful not to remove too much silicone.
- Do not permit the sealant to skin over after it has been tooled. Immediately remove the masking tape after tooling the sealant.

See **Detail 45**.

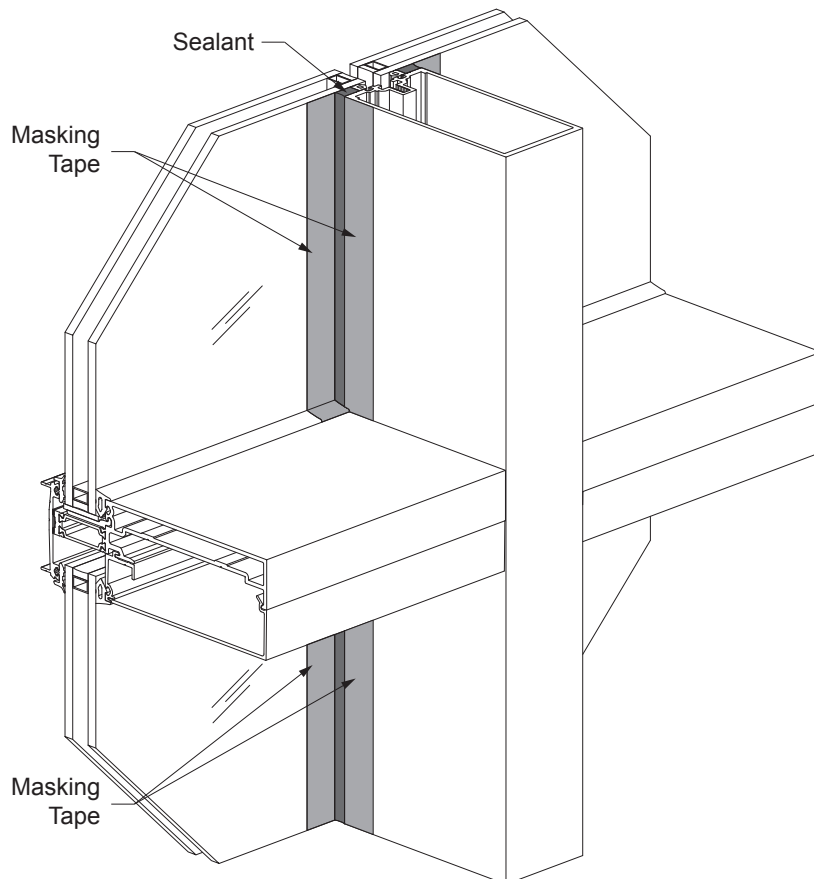

Detail 45

GLAZING

STEP 26 INSTALL EXTERIOR HORIZONTAL FACE COVERS

-Snap on exterior horizontal face covers using a mallet and clean piece of lumber.
Start at one end. Work block and mallet across the horizontal.

-If horizontal face covers are spliced, apply
bond breaker tape and sealant to the face
of the splice sleeve, E1-1202, and insert it
at the end of the first cover.

-Attach the second face cover leaving a 1/2"
joint between the two covers.

See **Detail 46**.

Note: Face cover splice joint should align
with the vertical glass joint.

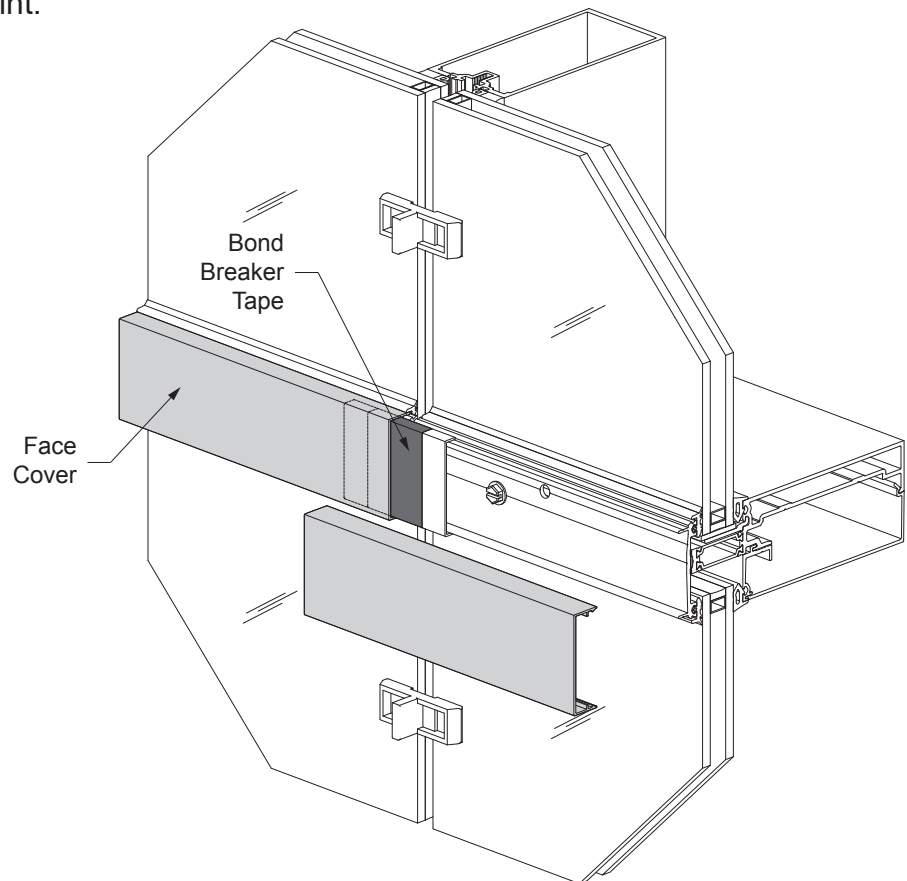

Detail 46

GLAZING

STEP 27

APPLY EXTERIOR WEATHERSEAL

- Once interior structural silicone has cured, remove the temporary retainer clips and insert an approved open cell polyurethane backer rod into the glass joint.
- Clean all silicone contact surfaces and joints with cleaner and method recommended by sealant manufacturer.
- Apply masking tape to the edges of the glass and aluminum as shown in **Detail 47**.
- Apply silicone sealant into the cavity between the mullion and glass starting from the bottom and work towards the top. Use positive pressure so that the silicone sealant completely fills the cavity.

Note: The underside of face cover splices are left unsealed to allow for weepage.

- Using a spatula or other non-scratching implement, tool the silicone sealant immediately after running the joint. Exert positive pressure while tooling to ensure that the silicone sealant makes complete contact with all surfaces. Be careful not to remove too much silicone.

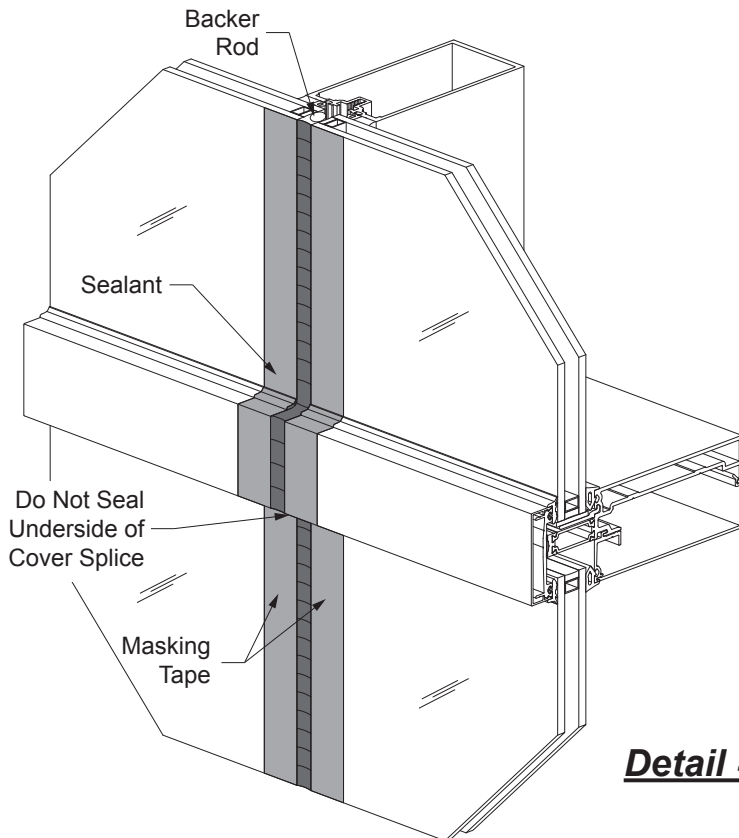

Detail 47

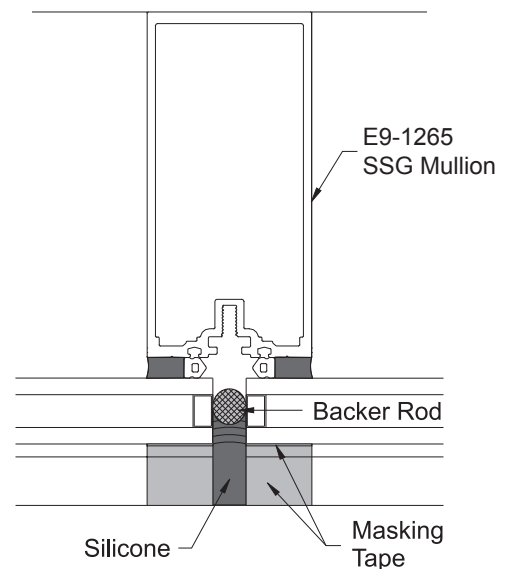

Caution: Do not permit the silicone to skin over before it is tooled. Immediately remove masking tape after tooling the silicone.



101 Marietta Street NW
Suite 2100
Atlanta, Georgia 30303
www.ykkap.com