

YCW 750 OGP Outside Glazed Curtain Wall System

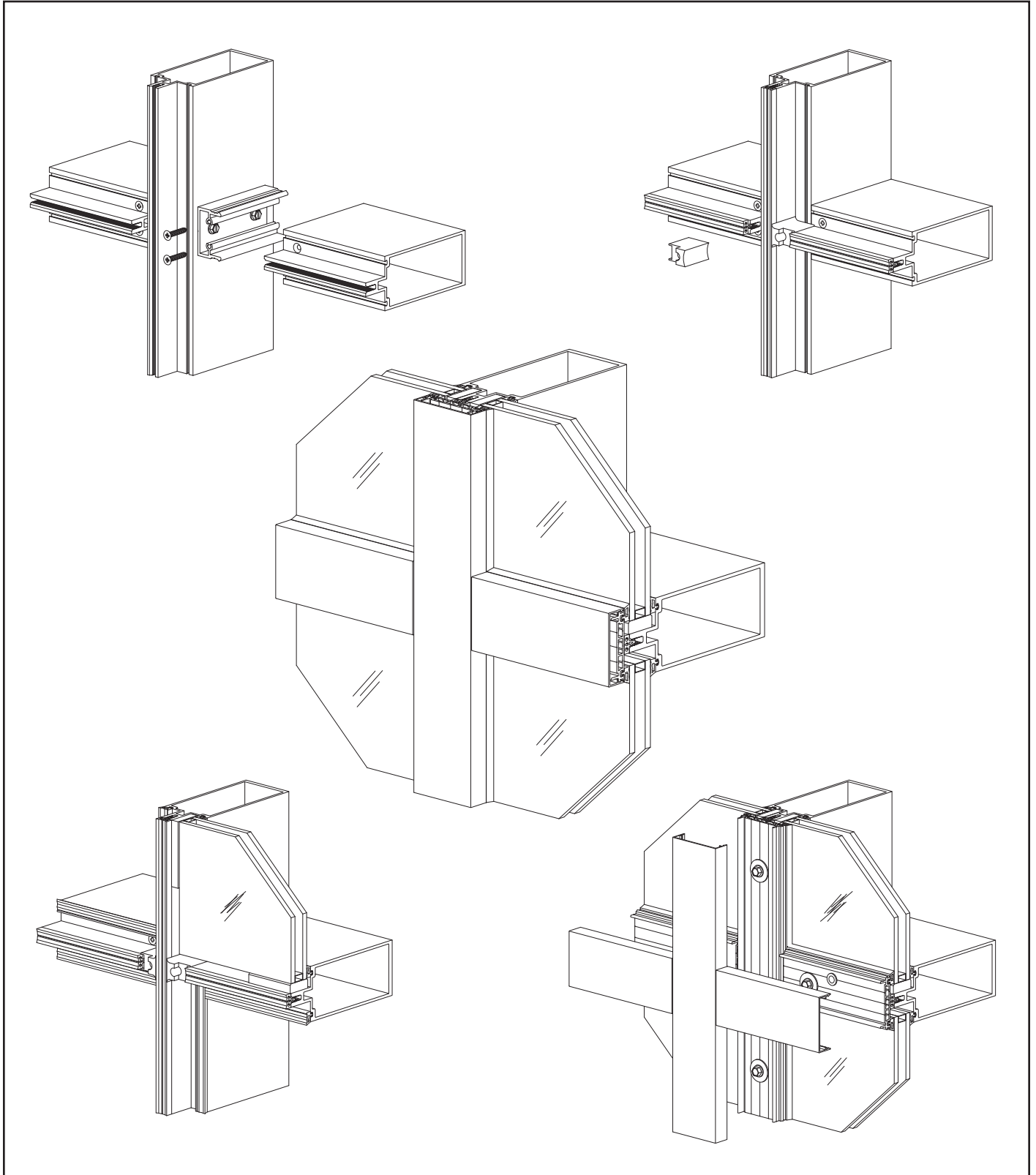

Installation Manual

TABLE OF CONTENTS

Installation Notes Page ii

PARTS DESCRIPTION

YCW 750 OGP Framing Members..... Pages 1 & 2

YCW 750 OGP Accessories..... Pages 2 to 5

FRAME FABRICATION

Anchoring Methods/Framing Types..... Pages 6 & 7

Fabricate Vertical Mullions Pages 8 & 9

Using Steel Reinforcing..... Page 10

Attach Shear Blocks/Clips for Horizontals..... Page 11

Attach “J” Anchors Page 12

Fabricate Horizontal Members Pages 13 to 15

Fabricate Pressure Plates Pages 16 & 17

Fabricate Face Covers Page 17

FRAME INSTALLATION

Typical Vertical Splice Pages 18 & 19

Install Continuous Perimeter Anchor..... Page 20

Jamb/Vertical Installation with Perimeter Anchors Page 21

Jamb Installation with Jamb Anchors Page 22

Jamb/Vertical Installation with Mullion End Anchors..... Page 23

Vertical Installation at Door Jamb End Anchors..... Page 24

Install Wind Load/Dead Load Anchors Pages 25 to 27

Attach Horizontal Members Pages 28 to 31

Install Door Subframes Page 32

Apply Perimeter Sealant..... Pages 33 to 34

(Optional) Install PVC Perimeter Filler Page 35

Add Thermal Isolator Page 36

Install Joint Plugs..... Page 37

GLAZING

Install Glazing Adaptors..... Page 38

Install Interior Glazing Gaskets Page 39

Install Setting & Side Blocks Page 40

Install Exterior Glazing Gaskets Page 41

Install Glass Page 41

Install Vertical Pressure Plates and Vertical Face Covers..... Pages 42 & 43

Install Horizontal Pressure Plates Page 44

Install Horizontal Face Covers Page 45







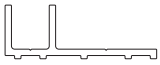

Installation Notes

1. Do not drop, roll or drag boxes of aluminum framing. Move and stack boxes with proper support to prevent distortion. If fork lifts are used, be especially careful about striking the boxes when lifting or moving.
2. Store in a dry, out of the way area. If rain exposure, condensation or any water contact is likely, then all packaging material should be removed. Wet packaging materials will discolor and may stain aluminum finishes and paints.
3. All materials should be checked for quality and quantity upon receipt, YKK AP must be notified immediately of any discrepancies in shipment. Check to make sure that you have the required shims, sealants, supplies and tools necessary for the installation.
4. Carefully check the openings and surrounding conditions that will receive your material. Remember, if the construction is not per the construction documents, it is your responsibility to notify the general contractor in writing. Any discrepancies must be brought to the general contractor's attention before you proceed with the installation.
5. These installation instructions are of a general nature and may not cover every condition you will encounter. The shop drawings prepared should be specifically for the project.
6. Any material substitutions must be of equal or greater quality.
7. Make certain that material samples have been sent for compatibility and adhesion testing for all manufacturer's sealants involved. Make certain sealants have been installed in strict accordance with the sealant manufacturer's recommendations and specifications.
8. Remember to isolate, in an approved manner, all aluminum from uncured masonry or other incompatible materials.
9. System-to-structure fasteners are not supplied by YKK AP. Fasteners called out on shop drawings are to indicate minimum sizes for design loading.
10. If any questions arise concerning YKK AP products or their installation, contact YKK AP for clarification before proceeding.
11. YKK AP storefront and/or curtain wall framing is typically completed before drywall, flooring and other products which may still be in process. Take the extra time to wrap and protect the work produced.
12. Cutting tolerances are plus zero, minus one thirty second unless otherwise noted.
13. Check our website, www.ykkap.com, for the latest installation manual update prior to commencing work.















FRAMING MEMBERS

	Vertical / Horizontal 2-1/2" x 5-1/4" For 1" Glazing	E9-1215		Horizontal Open Back 2-1/2" x 3-3/4" For 1" Glazing	E9-3585
	Vertical / Horizontal 2-1/2" x 5-1/4" For 1" Glazing	E9-1225		Horizontal Flush Filler For 5-1/4" Depth Open Back Members	E9-3162
	Vertical / Horizontal 2-1/2" x 3-3/4" For 1" Glazing	E9-1235		Horizontal Flush Filler For 3-3/4" Depth Open Back Members	E9-3595
	Vertical / Horizontal Heavy Duty 2-1/2" x 3-3/4" For 1" Glazing	E9-3537		Polyamide Pressure Plate For 1" Glazing	AS-3617
	Vertical / Horizontal 2-1/2" x 6-3/4" For 1" Glazing	E9-1242		Face Cover 2-1/2 x 3/4"	E9-1206
	Jamb Open Back 2-1/2" x 5-1/4" For 1" Glazing	E9-3580		Face Cover 2-1/2" x 2-3/8"	E9-1219
	Jamb Open Back 2-1/2" x 3-3/4" For 1" Glazing	E9-3584		Horizontal Face Cover 11/16" x 2-1/2"	E9-1207
	Head / Sill Open Back 2-1/2" x 5-1/4" For 1" Glazing	E9-3579		Bull Nose Face Cover 2-1/2" x 2"	E9-1293
	Head / Sill Open Back 2-1/2" x 3-3/4" For 1" Glazing	E9-3583		Glazing Adaptor For 1/4" glazing	E9-1220
	Optional Head For Incidental Water 2-1/2" x 5-1/4" For 1" Glazing	E9-3582		Glazing Adaptor For 1/2" Glazing	E9-1232
	Optional Head For Incidental Water 2-1/2" x 3-3/4" For 1" Glazing	E9-3586		Flush Pocket Filler For 1" glazing	E9-1253
	Horizontal Open Back 2-1/2" x 5-1/4" For 1" Glazing	E9-3581		Optional PVC Perimeter Adaptor For 1" Glazing	E3-3665

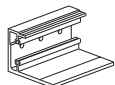
FRAMING MEMBERS

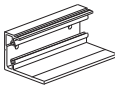
	Perimeter Anchor For 1" Glazing	E9-1223		Snap-In Door Stop For 20D/35D/50D Doors E2-0051 Gasket Included Use with E9-1224 & E9-3513	AS-0417
	Perimeter Channel For 1" Glazing	E9-1231		Heavy Duty Transom Bar For 40M/50M Doors E2-0051 Gasket Included	AS-0467
	Single Acting Transom Bar For 20D/35D/50D Doors E2-0051 Gasket Included	AS-0402		Heavy Duty Door Jamb For 40M/50M Doors Use with AS-0458	E9-3617
	Standard Door Jamb For 20D/35D/50D Doors & 1" Glazing Use with AS-0417	E9-3513		Snap-In Door Stop For 40M/50M Doors E2-0051 Gasket Included Use with E9-3617	AS-0458











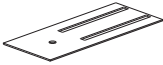

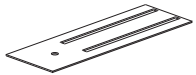

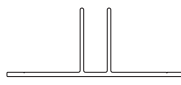
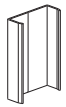
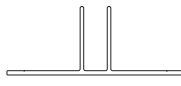





ACCESSORIES

	Standard Shear Block For 3-3/4" Back Depth 3.125" Long	E1-3503		Optional Shear Clip For 5-1/4" Back Depth Incidental Water Head	E1-3019
	Standard Shear Block For 5-1/4" Back Depth 4.375" Long	E1-3504		Shear Block (For E-Slot) For 3-3/4" Back Depth 3.125" Long	E1-1206
	Standard Shear Block For 6-3/4" Back Depth 6.000" Long	E1-3506		Shear Block (For E-Slot) For 5-1/4" Back Depth 4.375" Long	E1-1200
	"J" Anchor For 3-3/4" Back Depth 3.125" Long	E1-3501		Shear Block (For E-Slot) For 6-3/4" Back Depth 6.000" Long	E1-1236
	"J" Anchor For 5-1/4" Back Depth 4.375" Long	E1-3502		Mullion Splice Sleeve For 3-3/4" Back Depth	E1-1212
	"J" Anchor For 6-3/4" Back Depth 6.000" Long	E1-3505		Mullion Splice Sleeve For 5-1/4" Back Depth	E1-1201
	Optional Shear Clip For 3-3/4" Back Depth Incidental Water Head	E1-3523		Mullion Splice Sleeve For 6-3/4" Back Depth	E1-1299











* Splay mullions and other face covers are available, contact YKK AP.

** For use on vertical systems (perpendicular to ground). Use aluminum pressure plate for other applications after review by YKK AP's engineering department.













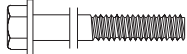

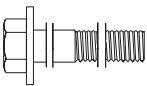

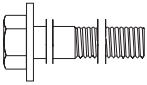



ACCESSORIES

	Mullion Splice Sleeve For 3-3/4" Back Depth Open Back Jamb	E1-1354		Mullion End Cap For 3-3/4" Depth Optional Incidental Water Head	E1-3527
	Face Cover Splice Sleeve For E9-1206	E1-1202		Mullion End Cap For 5-1/4" Depth Optional Incidental Water Head	E1-3526
	Mullion "T" Anchor For E9-1235 & E9-3537 3.462" Long	E1-1207		Optional Jamb Anchor Clip For Open Back Jamb E9-3584 & E9-3592	E1-3524
	Mullion "T" Anchor For E9-1215 Only 4.866" Long	E1-1208		Optional Jamb Anchor Clip For Open Back Jamb E9-3580 & E9-3588	E1-3525
	Mullion "T" Anchor For E9-1225 4.960" Long	E1-1209		Wind Load Anchor Steel with Zinc Oxide Paint Refer to Shop Drawings for Anchor Dimensions	E1-1204* Project Specific
	Mullion "T" Anchor For E9-1242 6.453" Long	E1-1238		Dead Load Anchor Steel with Zinc Oxide Paint Refer to Shop Drawings for Anchor Dimensions	E1-1205* Project Specific
	Mullion "F" Anchor For E9-1235, E9-3537, & E9-3584 3.462" Long	E1-1232		Jamb Anchor Plate	E1-3536
	Mullion "F" Anchor For E9-1215 4.866" Long	E1-1233		Steel Reinforcement 2" x 4" x 1/4" Steel Tube With Zinc Oxide Paint	E1-0162
	Mullion "F" Anchor For E9-1225 & E9-3580 4.960" Long	E1-1231		Steel Reinforcement 2" x 4" x 1/4" Steel Tube & (2) 1/4" x 1-3/4" Steel Bars With Zinc Oxide Paint	E1-0154
	Mullion "F" Anchor For E9-1242 6.453" Long	E1-1240		Setting Block For 1/4" Glazing EPDM with Pressure Sensitive Adhesive	E2-0112
	Temporary Glass Retainer 2" Long	E1-3012		Setting Block For 1" Glazing EPDM	E2-0104
	Mullion End Cap 2.500" x 2.313" x 0.050"	E1-1286		Side Block For 1" Glazing EPDM	E2-0105

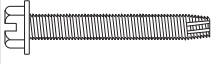
ACCESSORIES

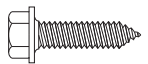
	<p>Standard Joint Plug For 1" Glazing EPDM Sponge</p>	<p>E2-0102</p>		<p>Interior/Exterior Glazing Gasket</p> <p>E2-0120</p>
	<p>Joint Plug For Slide-In Horizontal at End Bays, 1" Glazing Use with E2-0123</p>	<p>E2-0124</p>		<p>Weep Hole Tube</p> <p>E3-3125</p>
	<p>End Dam Plug Use with E9-1223 & E9-1231</p>	<p>E2-0505</p>		<p>Weep Baffle For Optional Incidental Water Head Members</p> <p>E2-0099</p>
	<p>E-Slot Plug For Slide-In Horizontal at End Bays</p>	<p>E2-0123</p>		<p>Anchor Slip Pad For Dead Load & Wind Load Anchors</p> <p>E3-0103</p>
	<p>Thermal Isolator Use with Polyamide Pressure Plate</p>	<p>E2-0265</p>		<p>Drill Fixture</p> <p>H-7210</p>

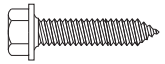
ACCESSORIES

	#8 x 3/8" PHSMS Zinc Plated Steel, For Attachment of Glazing Adaptors	PC-0806		1/4"-20 x 1" HWHMS Zinc Plated Steel, For Attachment of "J" Anchor at Jamb	HM-2516 -W3
	#8 x 1/2" PHSMS Type F Stainless Steel For Attachment of Face Cover Splice Sleeves	PF-0808 -SS		1/4"-20 x 3-1/2" HWHMS Zinc Plated Steel, For Attachment of "J" Anchor at Intermediate Vertical	HM-2556 -W3
	#12 x 1/2" PHSMS Type AB , Zinc Plated Steel For Attachment of Optional Head to Shear Clips	FC-1208		1/2"-13 x 2" HWHMS Zinc Plated Steel, For Attachment of Windload/ Deadload Anchor at Jamb	HM-5032
	#8 x 1/2" FHSMS Type AB Stainless Steel For Attachment of Deep Face Cover at Exposed Area	FC-0808 -SS		1/2"-13 x 4-1/2" HWHMS Zinc Plated Steel, For Attachment of Windload/ Deadload Anchor at Mullion	HM-5072
	#12 x 3/4" FHSMS Type AB , Zinc Plated Steel, (Exposed Fasteners) For Attachment of Horizontal to Shear Block	FC-1212		1/2"-13 Nut HHMS Zinc Plated Steel For Attachment of Mid-Anchors (Wind Load / Dead Load)	HM-5000
	#12 x 1-1/4" FHSMS Type AB, Zinc Plated Steel, (Concealed Fasten.) For Attach. of Horiz. to Shear Block	FC-1220		1/2" Flat Washer Zinc Plated Steel, For Attachment of Mid-Anchors (Wind Load / Dead Load)	WW-5000
	#14 x 5/8" FHSMS Type AB, Zinc Plated Steel, For Attachment of Mullion End Caps	FC-1410		1/2" Lock Washer Zinc Plated Steel, For Attachment of Mid-Anchors (Wind Load / Dead Load)	WS-5000
	1/4"-20 x 5/8" HWHS Type F, Zinc Plated Steel, For Attachment of Std. Shear Block to Vertical	HF-2510 -W1		1/4"-20 Nut HHMS Zinc Plated Steel, For Attachment of "J" Anchor at Intermediate Vertical & Jamb	HM-2500
	1/4"-20 x 1-3/4" HWHS Type F, Zinc Plated Steel, For Attachment of Opt. Shear Clip to Vertical	HF-2528 -W1		1/4" Fender Washer Stainless Steel, For Attachment of Polyamide Pressure Plate	FW-2500 -SS
	1/4"-20 x 1" HWHS Type CA, Stainless Steel, For Attachment of Temporary Glass Retainer	HD-2516 -W3-SS		1/4" Flat Washer Zinc Plated Steel, For Attachment of "J" Anchor	WW-2500
	1/4"-20 x 1-1/4" HWHMS Type CA, Stainless Steel, For Attachment of Polyamide Pressure Plate	HD-2520 -W3-SS		1/4" Lock Washer Zinc Plated Steel, For Attachment of "J" Anchor at Intermediate Vertical & Jamb	WS-2500

FRAME FABRICATION

FRAME TYPES / ANCHORING METHODS

The following is a guideline for common types of frames. Refer to shop drawings for exact layout of frames.

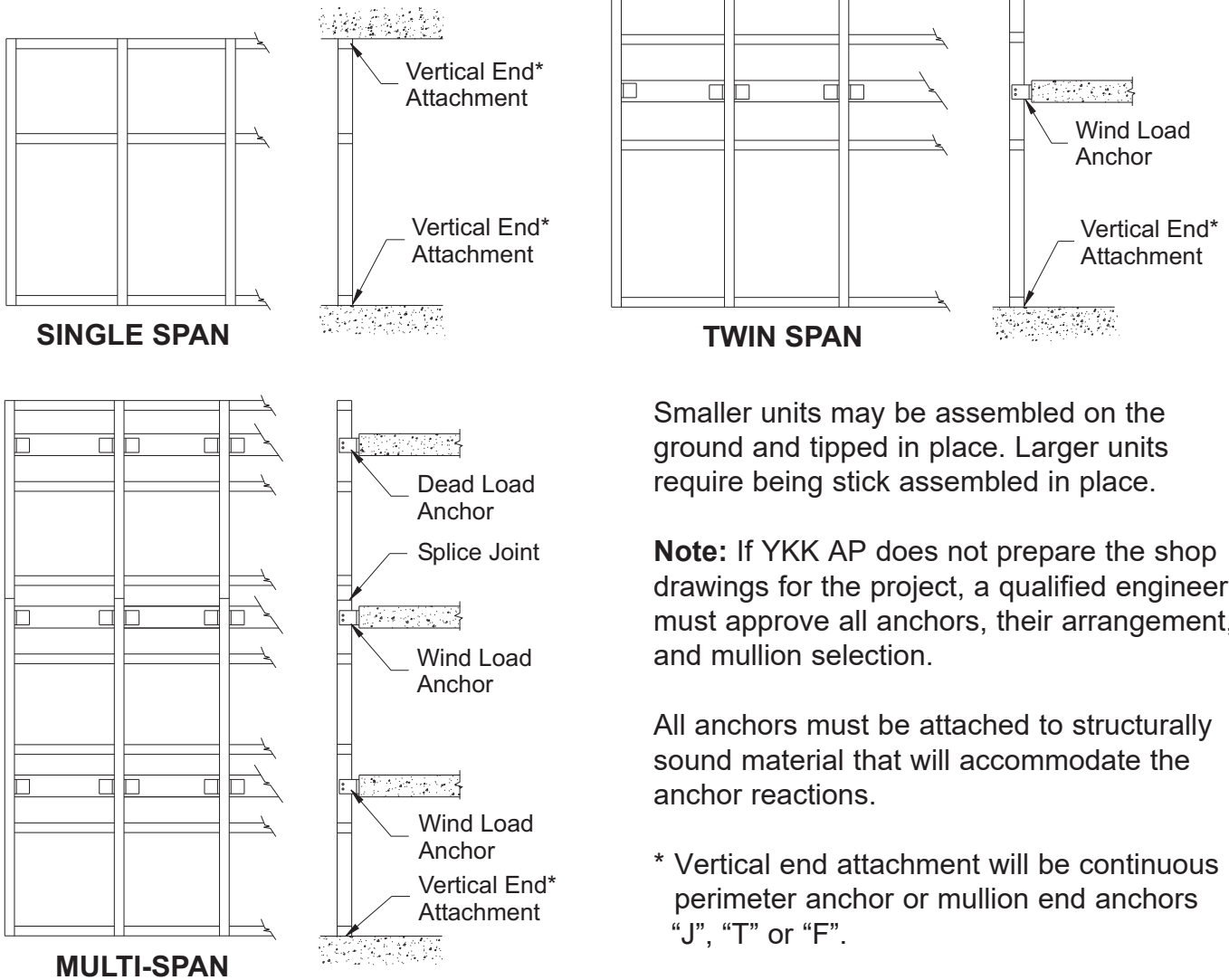

Smaller units may be assembled on the ground and tipped in place. Larger units require being stick assembled in place.

Note: If YKK AP does not prepare the shop drawings for the project, a qualified engineer must approve all anchors, their arrangement, and mullion selection.

All anchors must be attached to structurally sound material that will accommodate the anchor reactions.

* Vertical end attachment will be continuous perimeter anchor or mullion end anchors "J", "T" or "F".

Fabrication of YCW 750 OG varies depending on the type of vertical end attachment required for a given project:

Perimeter Anchors are for low load anchoring conditions (maximum 500lb. end load reaction): E9-1223 & E9-1231.

"J" Anchors are for medium to high load conditions: E1-3501, E1-3502, & E1-3505.

"T" & "F" Anchors are for high load conditions: E1-1207, E1-1208, E1-1209, E1-1231, E1-1232, & E1-1233.

FRAME FABRICATION

FRAME TYPES / ANCHORING METHODS

Using Perimeter Anchors:

-Vertical mullions must be notched as shown in **Detail 1** on **Page-7**.

Using Mullion End Anchors:

YCW 750 OG has three possible end anchoring conditions: "J", "T", and "F".

- "J" anchors are used with jambs and intermediate verticals at the sill only.
- "T" anchors are used with intermediate verticals at the head and sill.
- "F" anchors are used with jamb mullions at the head and sill.
- Anchor usage depends on end reaction, stress, and attachment.

Mullions should be pre-assembled with shear blocks/clips, end anchors, and steel or aluminum reinforcing if necessary.

End anchors should be pre-drilled for anchor fasteners according to approved shop drawings or engineering calculations.

Framing Members for Stick Build:

- Open back head and sill members provide easy access to end anchor bolts.
- Closed horizontal members are used at all intermediate locations except at end bays.
- Open back intermediate horizontals are used at end bays to clear the shear blocks.

Note: When using stick build construction, check overall frame width every fifth mullion as the wall is installed. A buildup of cumulative tolerance errors may occur, resulting in excessive DLO spacing.

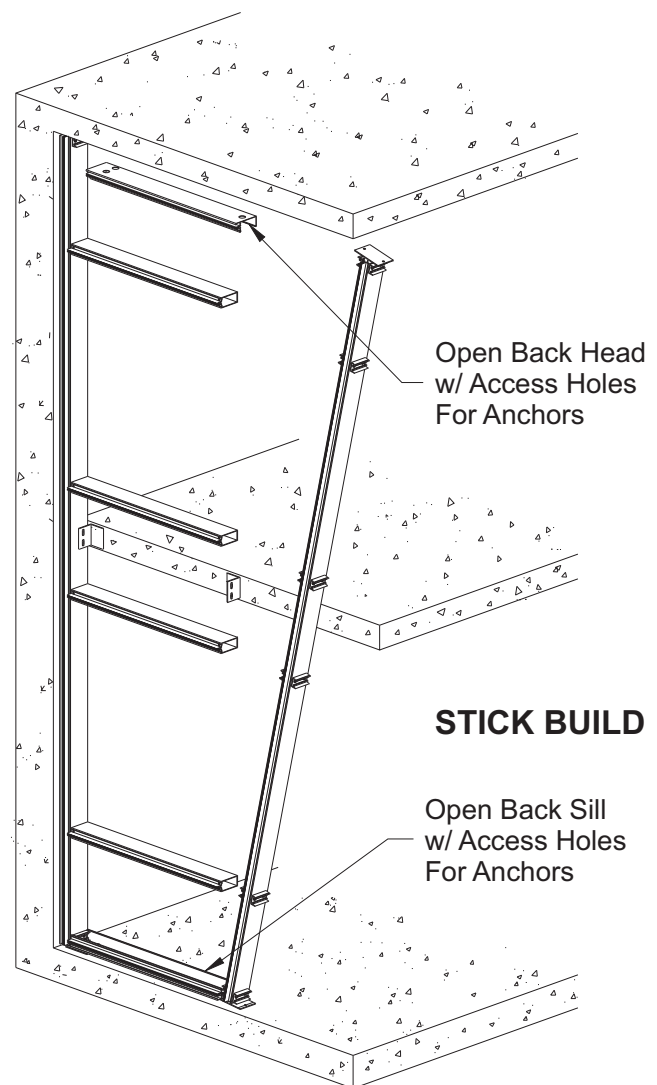

FRAME FABRICATION

FABRICATE VERTICAL MULLIONS

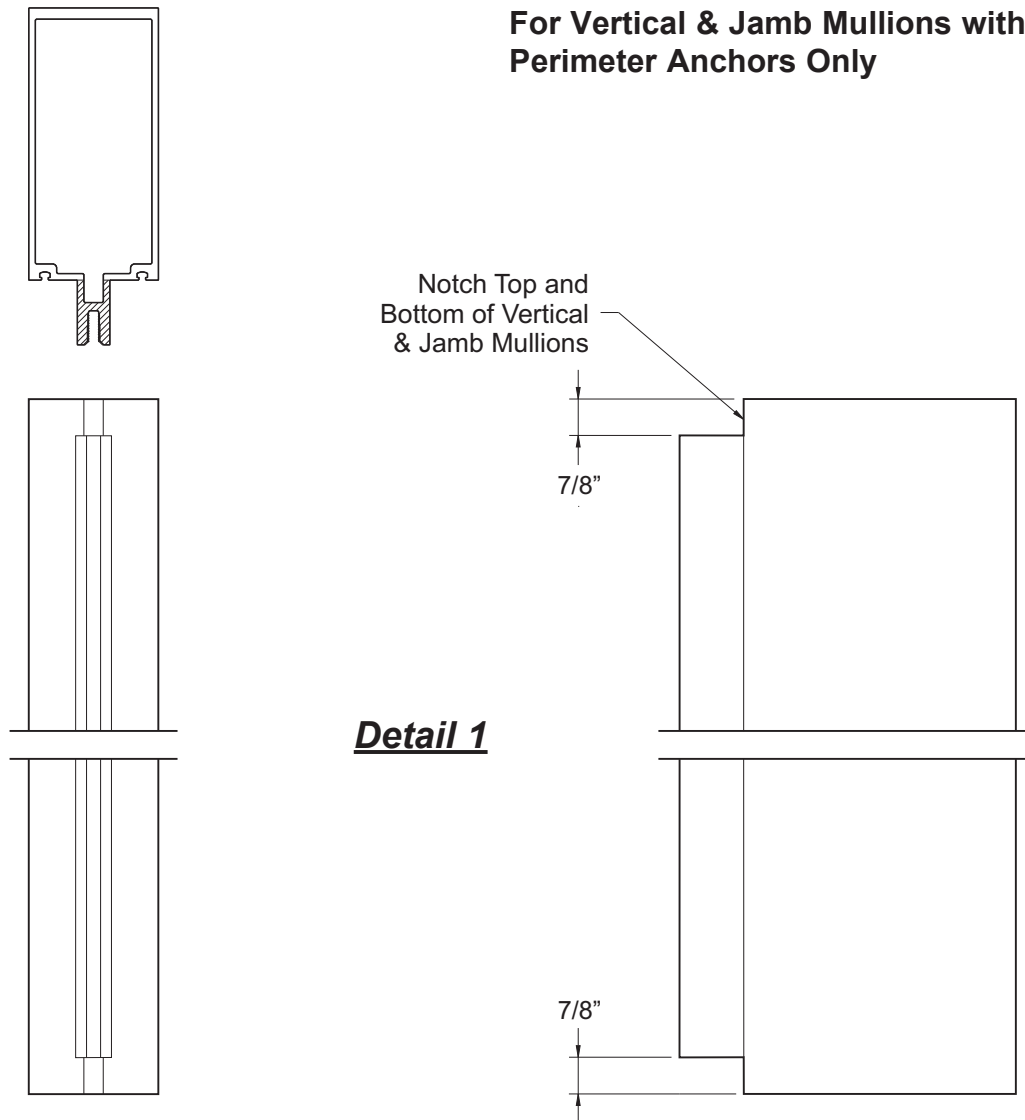

Step 1

-Cut all vertical and jamb mullions to dimensions as shown on shop drawings.
Allow for 1/2" caulk joint around the frame & 1/2" joint at vertical splices.

Note: Mullions at door jambs are sealed against the substrate at the sill without a shim space at that location.

Step 2

-When using continuous perimeter anchors, E9-1223 or E9-1231, the top and bottom of vertical and jamb mullions must be notched as shown in **Detail 1**, and sealed as shown on **Page 22**.

Note: Do not notch verticals when using mullion end anchors: "J", "T" or "F".

FRAME FABRICATION

STEP 3
FABRICATE VERTICAL MULLIONS

- Mullion hole locations for shear blocks, shear clips, and “J” anchors are shown below.
 - Drill 0.213” dia. (#3 bit) holes for shear block/clip attachment at the locations indicated.
 - Drill 0.281” dia. (#9/32 bit) holes for “J” anchor attachment at the sill at the locations indicated.
- See **Detail 2**.

Note: Hole locations for standard shear blocks are not the same as shear clips for optional incidental water head.

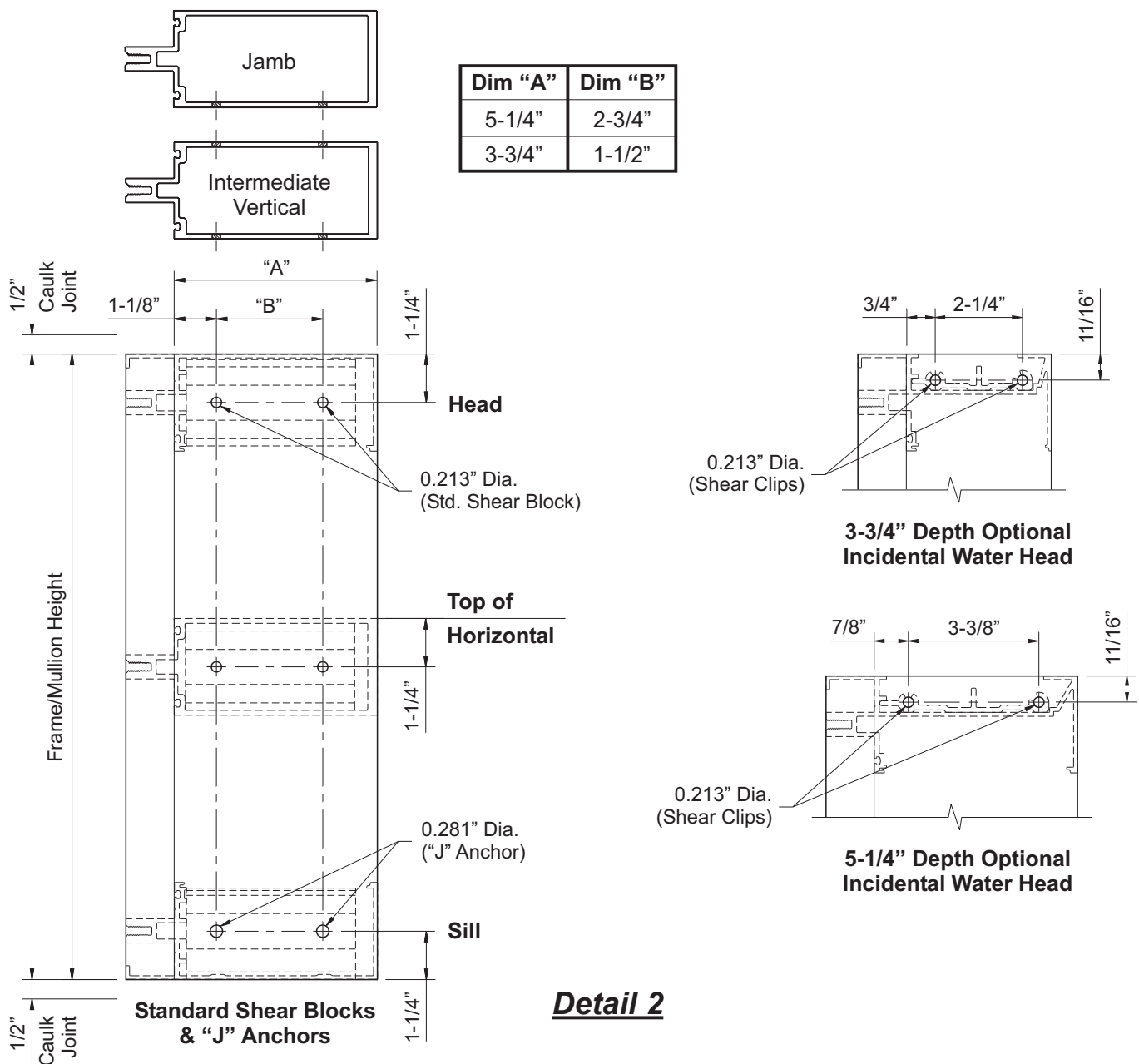

Detail 2

FRAME FABRICATION

**STEP 4 (Optional)
USING STEEL REINFORCING**

-Steel reinforcing must be primed/coated to insulate the steel from the aluminum.

When engineering calculations require the vertical mullions to be reinforced with steel, secure the reinforcing to the vertical using the appropriate fasteners.

- Start 3" from both ends of the mullion and install a fastener on both sides of the mullion tongue.
- Stagger the fasteners on either side of the tongue going up the vertical.
- Apply sealant to all screw heads.

Note: Exact size of reinforcing, size and location of fasteners to be determined by a qualified engineer.

Steel reinforcing is also attached on the sides of the mullion with the attachment of shear blocks.

- Drill 0.281" dia. (9/32 bit) clear holes in the mullion only.
- Match drill 0.213 dia. (#3 bit) tap holes in the reinforcing only.
- Attach the shear blocks with HF-2516-W1 fasteners.

See **Detail 3**.

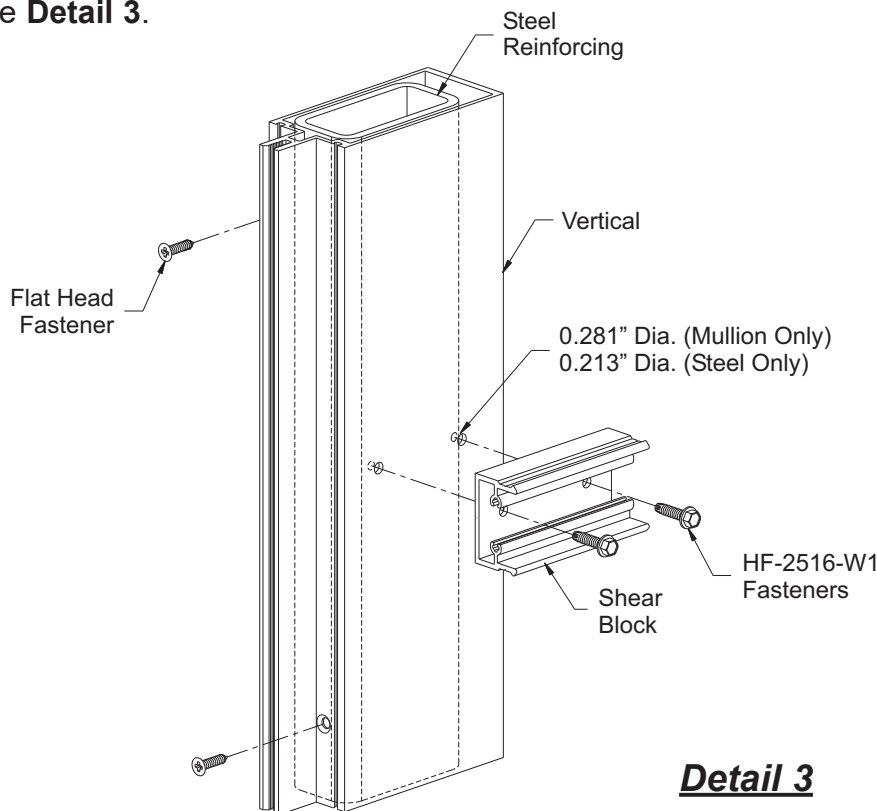

Detail 3

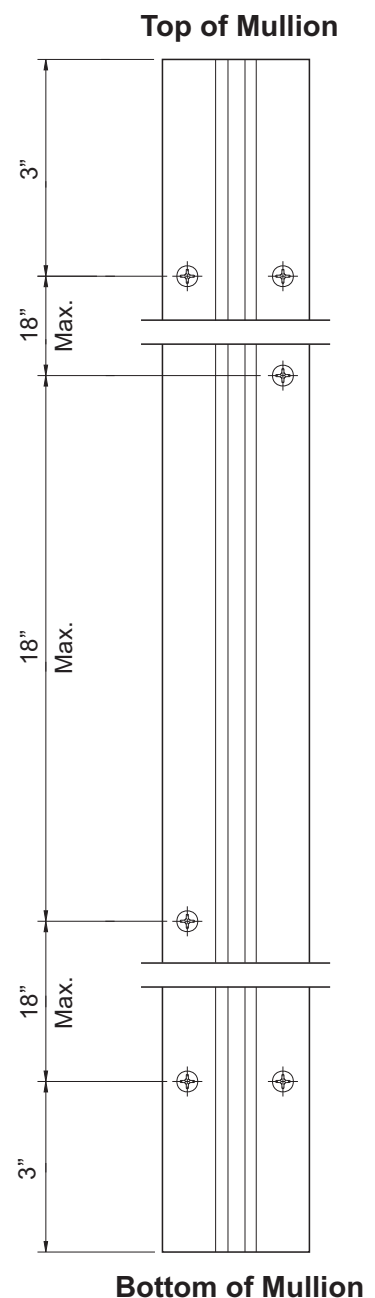

FRAME FABRICATION

STEP 5
ATTACH SHEAR BLOCKS/CLIPS FOR HORIZONTALS

Standard shear blocks are used to attach horizontal members to the jambs and verticals. Shear blocks for E-Slots (E1-1200 & E1-1206) are attached the same way.

E1-3503 for 3-3/4" back members.

E1-3504 for 5-1/4" back members.

-Attach shear blocks to jambs and verticals with (2) HF-2510-W1 fasteners per block.

Shear clips are used to attach optional incidental water head members to the jambs and verticals.

E1-3523 for 3-3/4" back members.

E1-3019 for 5-1/4" back members.

-Attach shear clips to jambs and verticals with (2) HF-2528-W1 fasteners per block.

See **Detail 4**.

Note: Do not attach standard shear blocks at the head and sill for end bays at this time. See **Step 16** for head and sill end bay attachment.

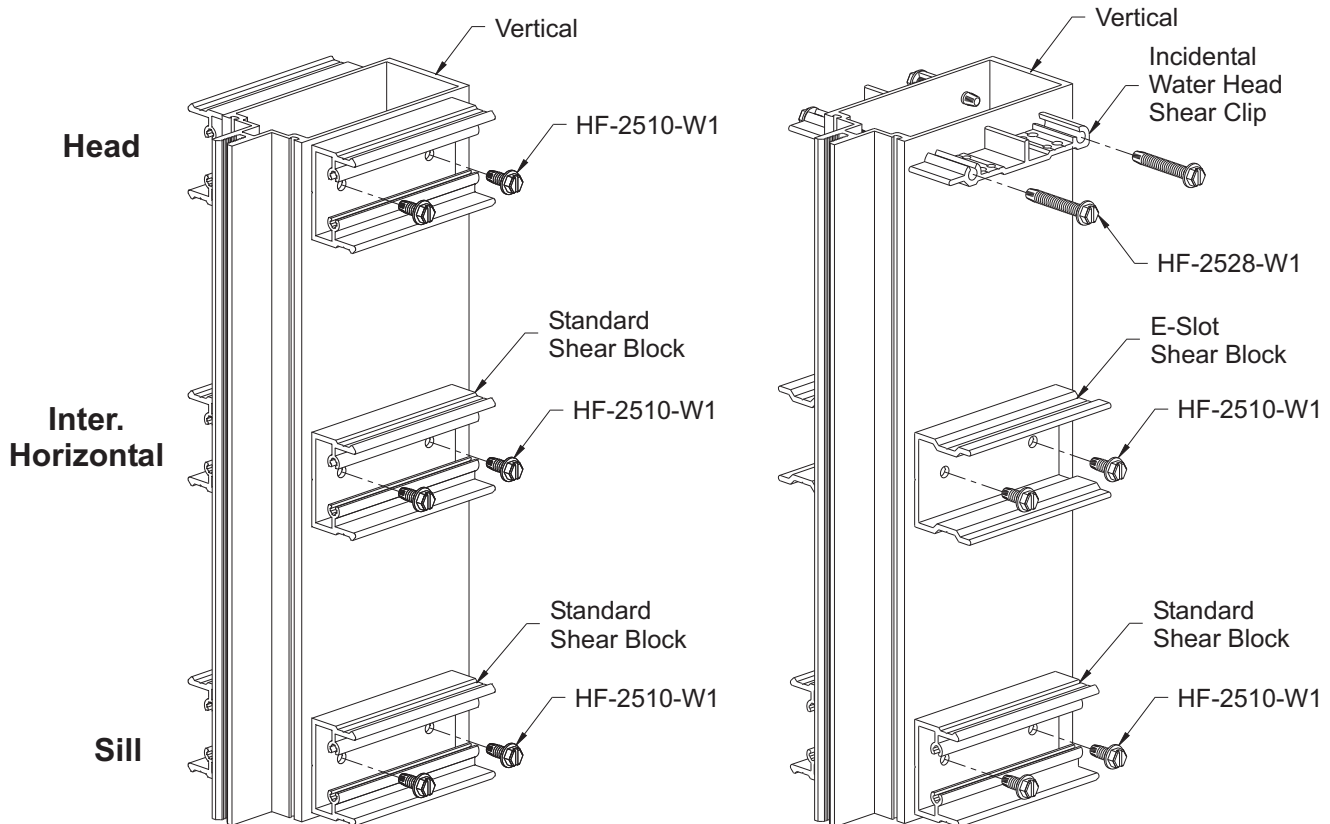

Detail 4

FRAME FABRICATION

**STEP 6
ATTACH "J" ANCHORS**

In addition to anchoring the curtain wall frame to the structure, "J" anchors are used to attach sill members to jamb and vertical mullions:

E1-3501 for 3-3/4" back members.

E1-3502 for 5-1/4" back members.

Note: "J" anchors are used at the sill only.

Attach "J" Anchors at Jamb:

-Align the "J" anchor with the mullion and insert the HM-2516 bolts through the inside of the mullion and out the "J" anchor.

-Install 1/4" flat and lock washers between the anchor and HM-2500 hex nuts.

Attach "J" Anchors at Intermediate Verticals:

-Align the "J" anchors and insert the HM-2556 bolts through both anchors and the mullion.

-Install 1/4" flat and lock washers between the anchor and HM-2500 hex nuts.

See **Detail 5**.

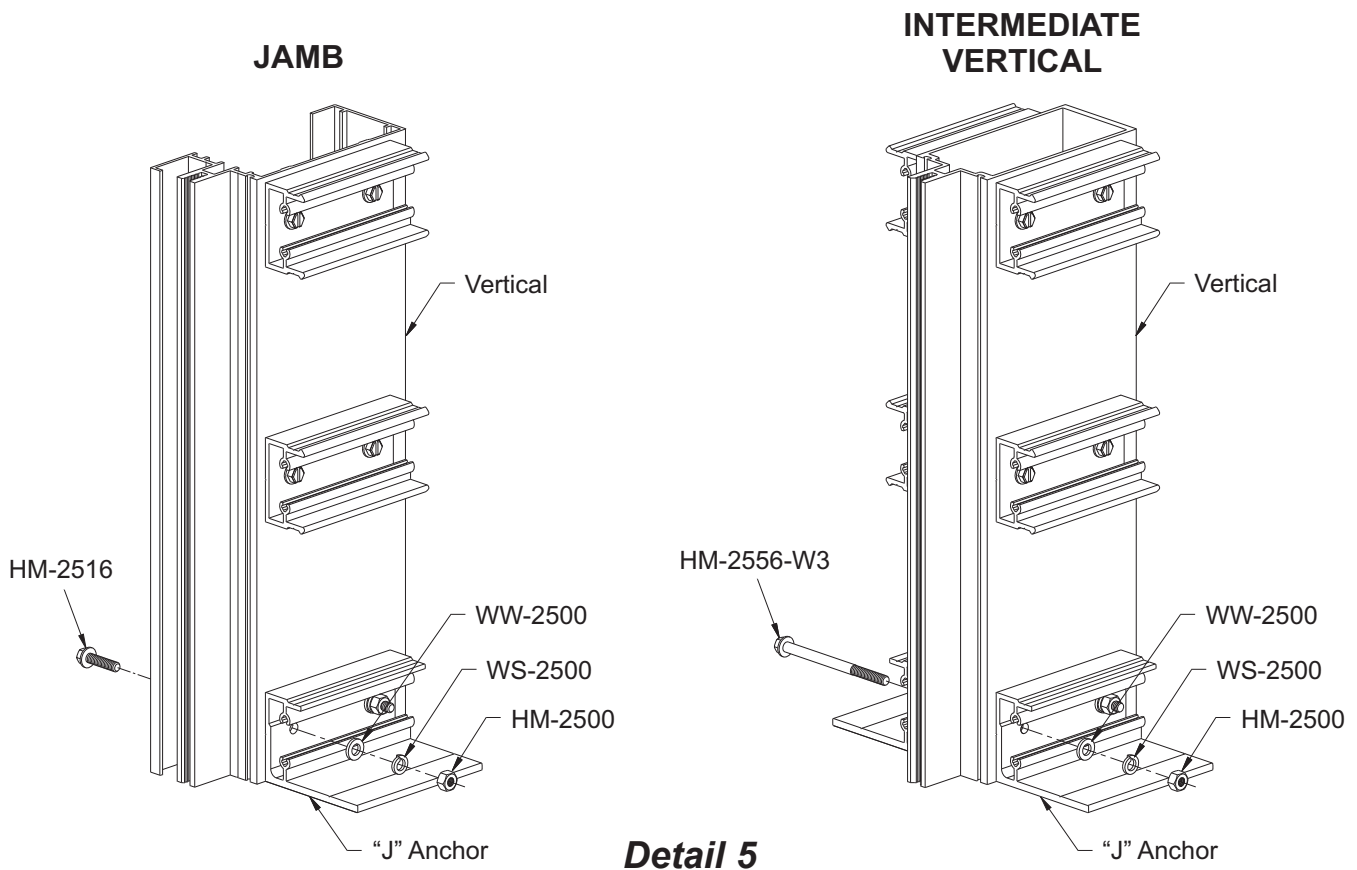

Detail 5

FRAME FABRICATION

**STEP 7
FABRICATE HORIZONTAL MEMBERS**

- Cut all horizontal members to the daylight opening as shown in shop drawings.
- Cut all horizontal flush fillers to the daylight opening minus(-) 1/32".
- Horizontal members must be fabricated for shear block/clip attachment as follows:

Horizontals with Concealed Fasteners:

- Layout hole locations on the face of the horizontal at both ends as shown below.
 - Drill 0.236" diameter (#B bit) holes and countersink for #12 flat head fasteners.
- See **Detail 6**.

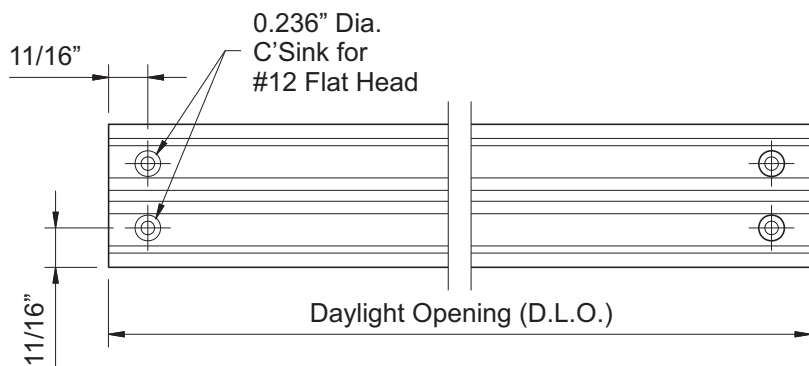

Detail 6

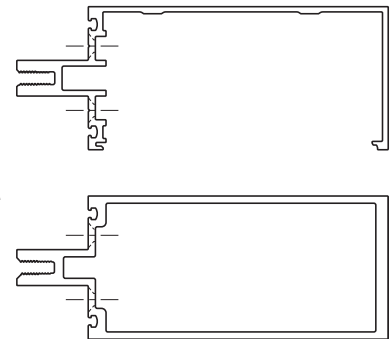

Horizontals with Exposed Fasteners:

- Layout hole locations on the top of the horizontal at both ends as shown below.
 - Drill 0.236" diameter (#B bit) holes and countersink for #12 flat head fasteners.
- See **Detail 7**.

Dim "A"	Dim "B"
5-1/4"	2-3/4"
3-3/4"	1-1/2"

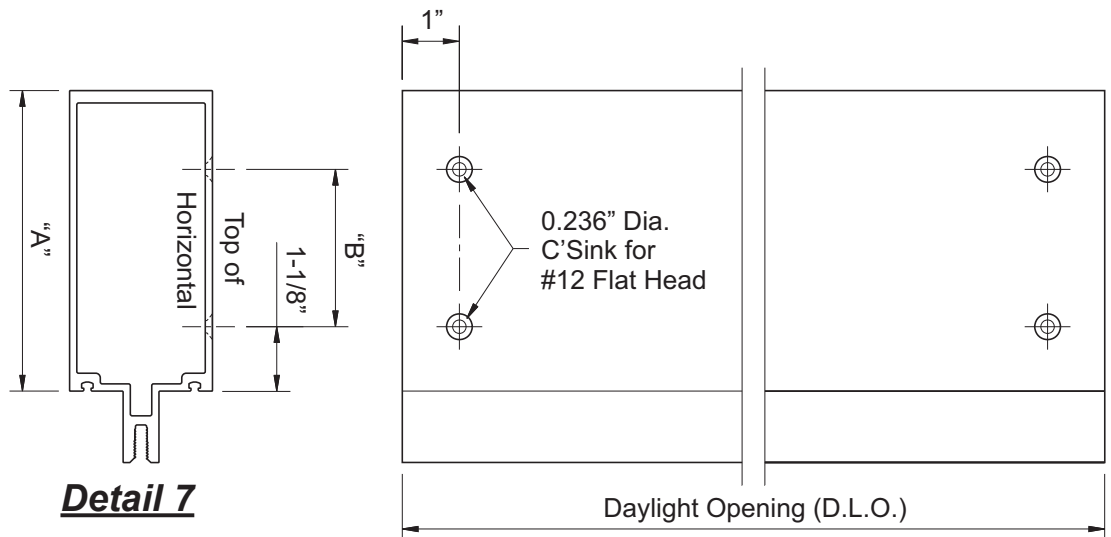

Detail 7

FRAME FABRICATION

STEP 7 (Continued)

FABRICATE HORIZONTAL MEMBERS

Open Back Head & Sill with “T” & “F” Anchors (5-1/4” & 3-3/4” Back Depths Only):

- Open back head & sill members require holes to access anchor bolts.
 - Drill 1-1/2” dia. holes at anchor locations as required by approved shop drawings or engineering calculations.
- See **Detail 8**.

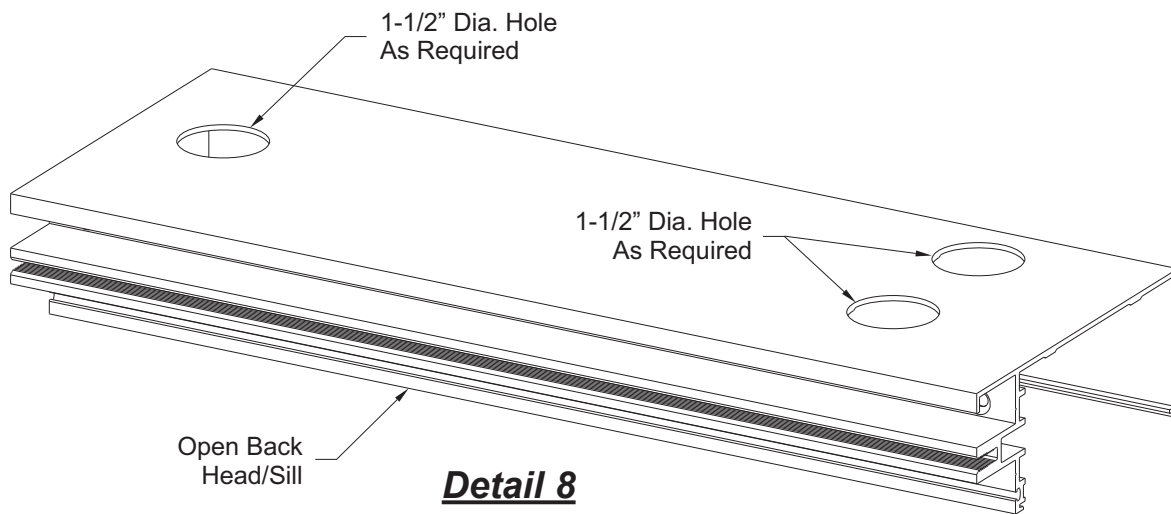

Tubular Head & Sill with “J”, “F” & “T” Anchors:

- Tubular head and sill members must be notched at each end to clear mullion end anchors and anchor bolts.
- See **Detail 9** below for notch dimensions.

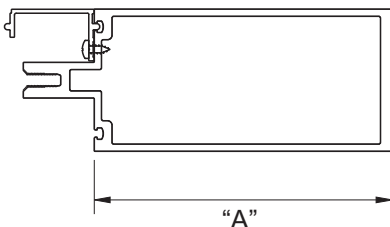

Dim "A"	Dim "B"
5-1/4"	4-3/4"
3-3/4"	3-1/4"

Notch Horizontal Ends to Clear End Anchors & Anchor Bolts

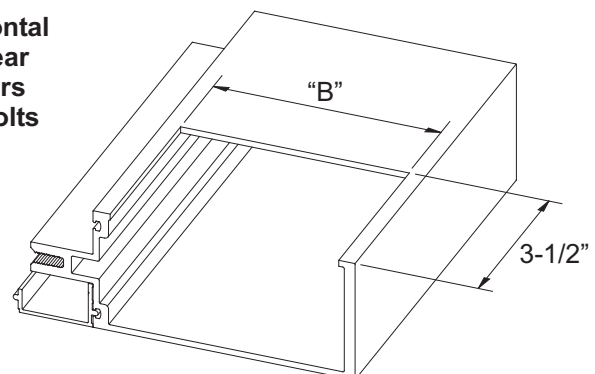

Detail 9

FRAME FABRICATION

**STEP 7 (Continued)
FABRICATE HORIZONTAL MEMBERS**

Optional Incidental Water Head (5-1/4" & 3-3/4" Back Depths Only):

- Layout hole locations on the bottom of the horizontal along the "V"-grooves at both ends.
- Drill 0.213" diameter (#3 bit) holes at each location.

Incidental water head members require weep holes along the top face of the mullion.

- Layout hole locations along the "V"-Groove of the top face as required according to approved shop drawings or engineering calculations.
- Drill 0.313" diameter weep holes at each location.

See **Detail 10**.

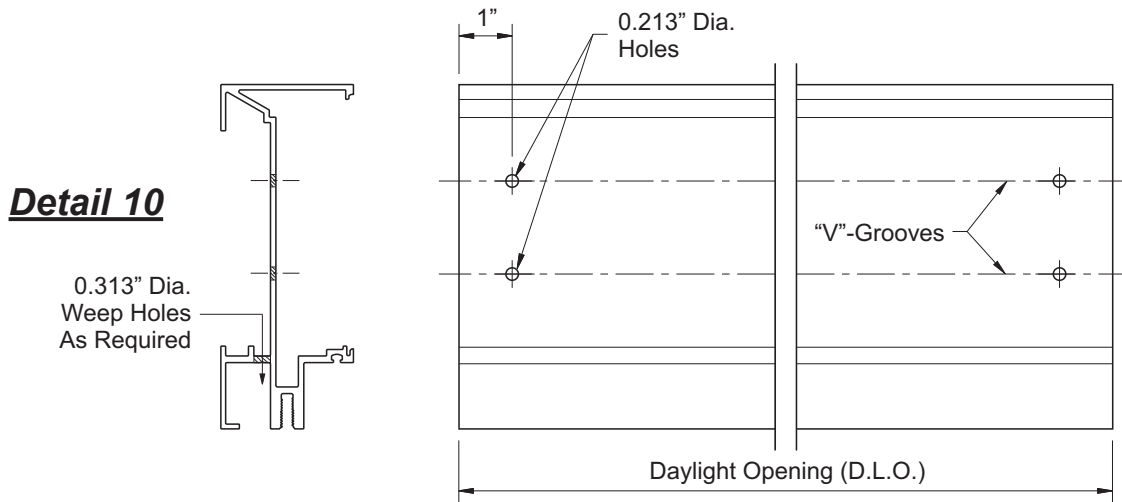

Optional Slide-In Tubular Horizontals at End Bays (E-SLOT):

When using tubular horizontals at end bays, horizontals must slide in from the interior.

- In order to clear the shear blocks on the verticals, notch the face and tongue of the horizontal at both ends as shown below.

See **Detail 11**.

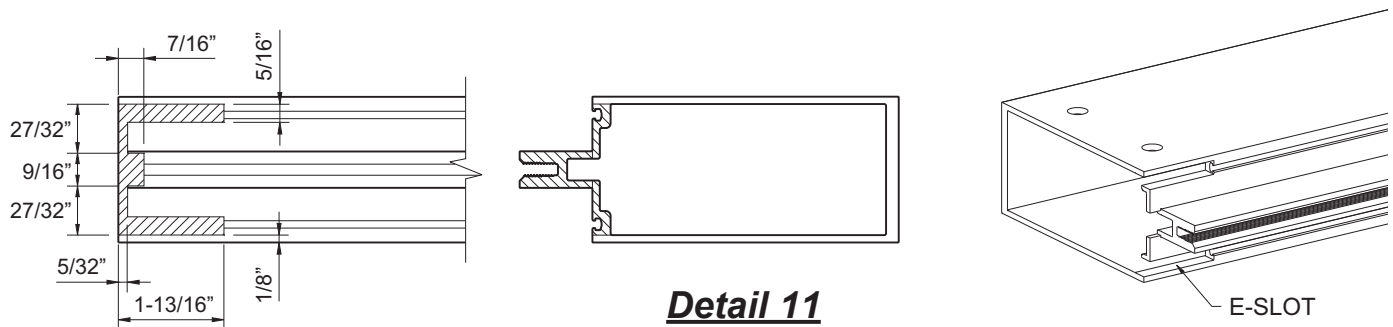

FRAME FABRICATION

STEP 8 FABRICATE PRESSURE PLATES

Horizontal Pressure Plates:

- Cut all head, sill, and intermediate horizontal pressure plates to the daylight opening between verticals minus(-) 1/2".
- Pressure plate stock lengths have 0.281" dia. holes factory drilled every 8" on center. After cutting, drill additional holes if required to ensure that end holes are 1-1/2" from each end.
- If factory drilled holes are less than 1-1/2" from the ends, interior and exterior holes must be sealed and tooled smooth.
- Using a 3/8" dia. spade drill bit, drill two 0.375" (3/8") diameter weep holes 3" from each end and one at the centerline of the pressure plate.

See **Detail 12**.

Note: If the space between the weep holes exceeds 3', additional weep holes should be drilled to ensure that there is no more than 3' between the weep holes.

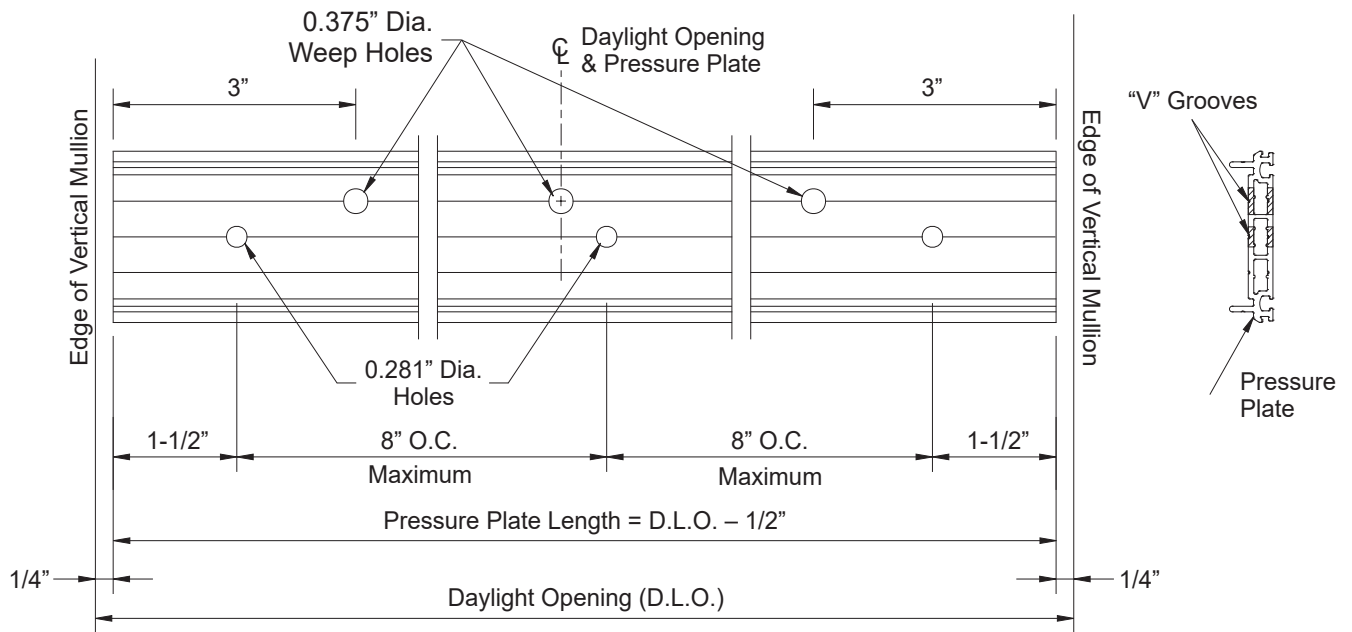

Detail 12

Horizontal Pressure Plates:

- Horizontal Pressure Plate must have E3-3125 5/16" weep tubes installed at each weep hole location.
- Insert the weep hole tube from the exterior side of the pressure plate until it is flush.
- Apply and tool sealant into both ends of pressure plate hollows.

See **Detail 12a**.

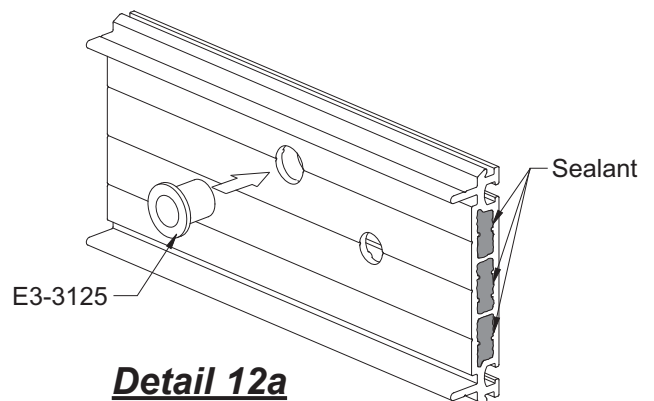

Detail 12a

FRAME FABRICATION

Vertical Pressure Plates:

- Cut vertical and jamb pressure plates and thermal isolators to the same length as the vertical mullions.
- If vertical mullions are spliced, cut pressure plates to accommodate for 1/2" expansion joint as shown in **Step 10** on **Pages 18 & 19**. Apply and tool sealant into the hollows of both pressure plates at the splice joint.
- Drill additional attachment holes if required to ensure that end holes are within 1-1/2" of each end.

STEP 9 FABRICATE FACE COVERS

Horizontal Face Covers:

- Cut horizontal face covers to the daylight opening between verticals minus(-) 1/16".
 - Drill two 0.313" diameter weep holes at 1/3 points of cover as shown below.
- See **Detail 13**.

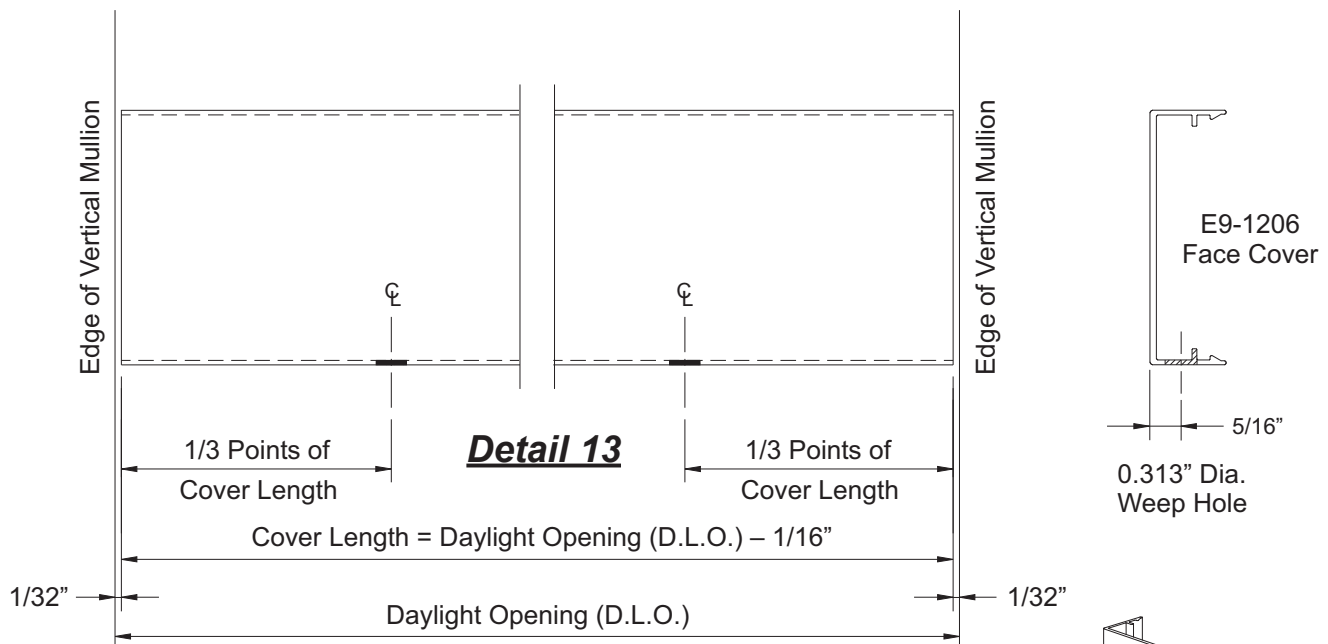

Vertical Face Covers:

- Cut vertical face covers to the same length as the vertical mullions unless the verticals are spliced.
- If vertical mullions are spliced, cut vertical covers to accommodate for the 1/2" expansion joint as shown in **Step 10**.
- Drill (1) 0.188" dia. hole in the bottom of each vertical cover as shown.

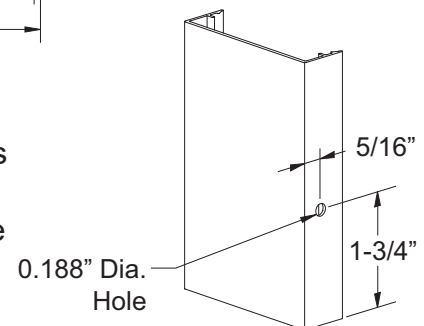

FRAME INSTALLATION

**STEP 10
TYPICAL VERTICAL SPLICE**

Stagger Mullion, Pressure Plate, and Cover Splice Joints as Shown Below.

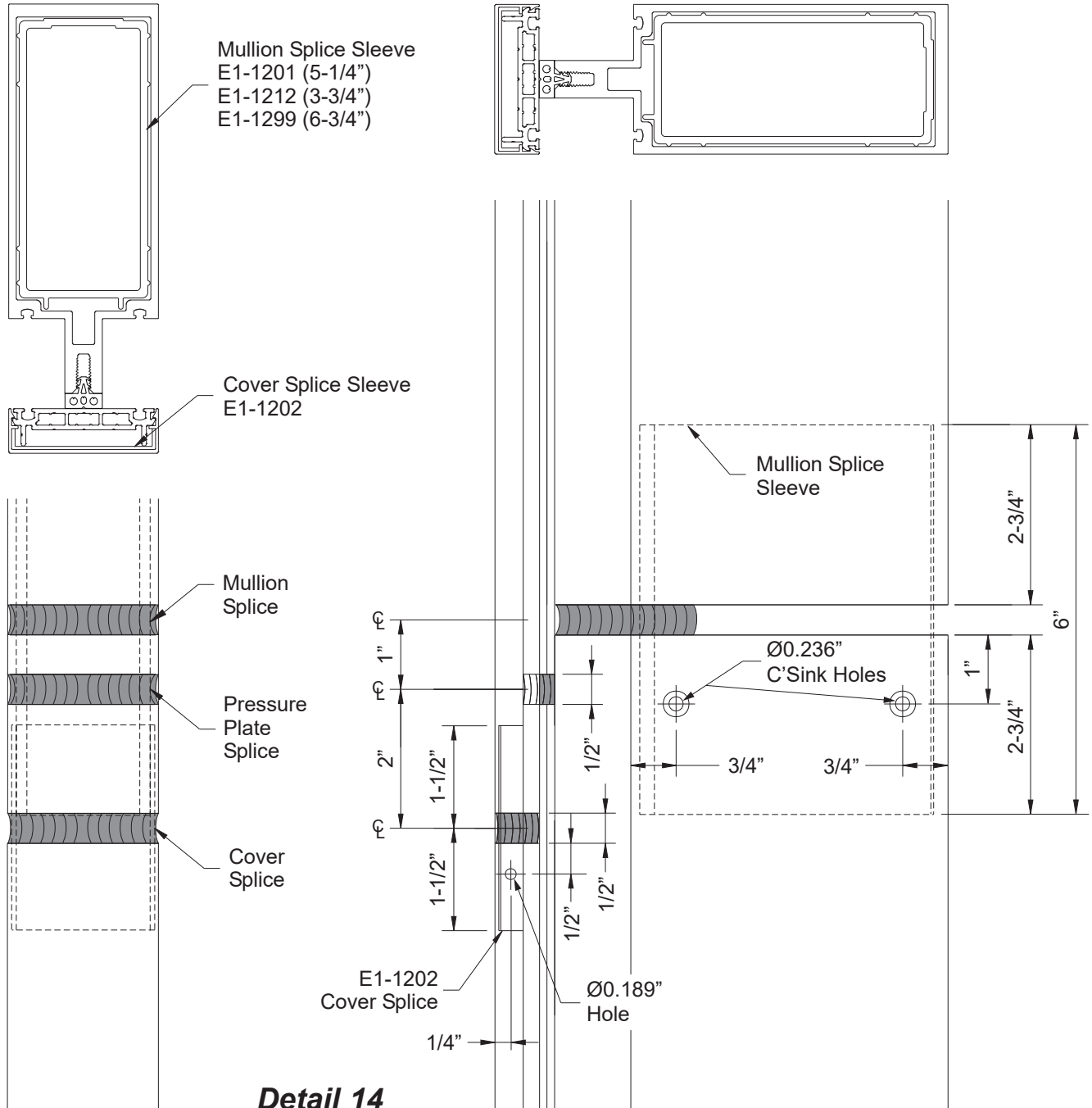

FRAME INSTALLATION

STEP 10 (Continued) TYPICAL VERTICAL SPLICE

- Clean all surfaces as recommended by sealant manufacturer.
- At 3/4" from the front and back of the lower mullion and down 1" from the top, drill Ø0.236" (#B drill bit) holes, and countersink for #12 flat head fasteners, on each side of the mullion.
- Apply bond breaker tape to the face of the splice sleeve at its midpoint (3" from top or bottom).
- Lower the splice sleeve into top of lower mullion 2-3/4" and attach with two FC-1212 fasteners on both sides of the mullion.
- When using 1" glazing mullions, stuff a small piece of backer rod 1/2" down the cavity behind mullion tongue and pump in sealant to fill the cavity.
- Apply sealant to the face of splice sleeve on the upper half and carefully slide the upper mullion down onto the splice sleeve. Place a 1/2" temporary shim between the mullions to locate them.
- Secure the upper mullion to the mid anchors and remove the temporary shims.
- Apply and tool sealant to the face and sides of the splice sleeve to create a water tight joint.

-Leave a 1/2" expansion joint between vertical pressure plate splices and fill the joint with sealant. Ensure the hollows in the pressure plates are sealed at the splice joint.

-Locate pressure plate fasteners 1-1/2" from each end of pressure plate splice as shown.

-Apply bond breaker tape to the face of the cover splice sleeve and attach it to the lower face cover with a PF-0808-SS fastener on each side.

-Prior to snapping on the upper portion of the face cover, apply sealant to the face of the splice.

-Leave a 1/2" expansion joint between face cover splices.

See **Details 14 & 15.**

Note: Face covers, pressure plates, and mullions are staggered at splice locations.

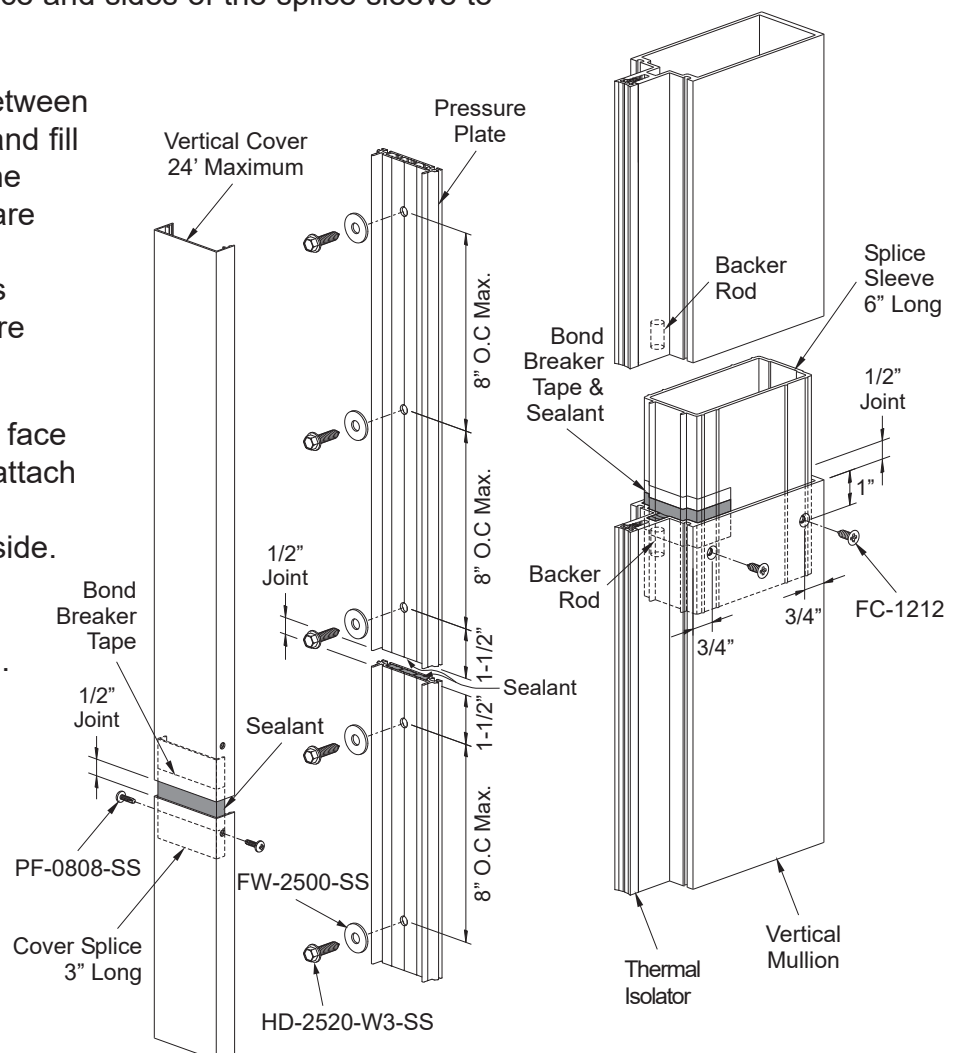

Detail 15

FRAME INSTALLATION

**STEP 11 (When Required)
INSTALL CONTINUOUS PERIMETER ANCHOR**

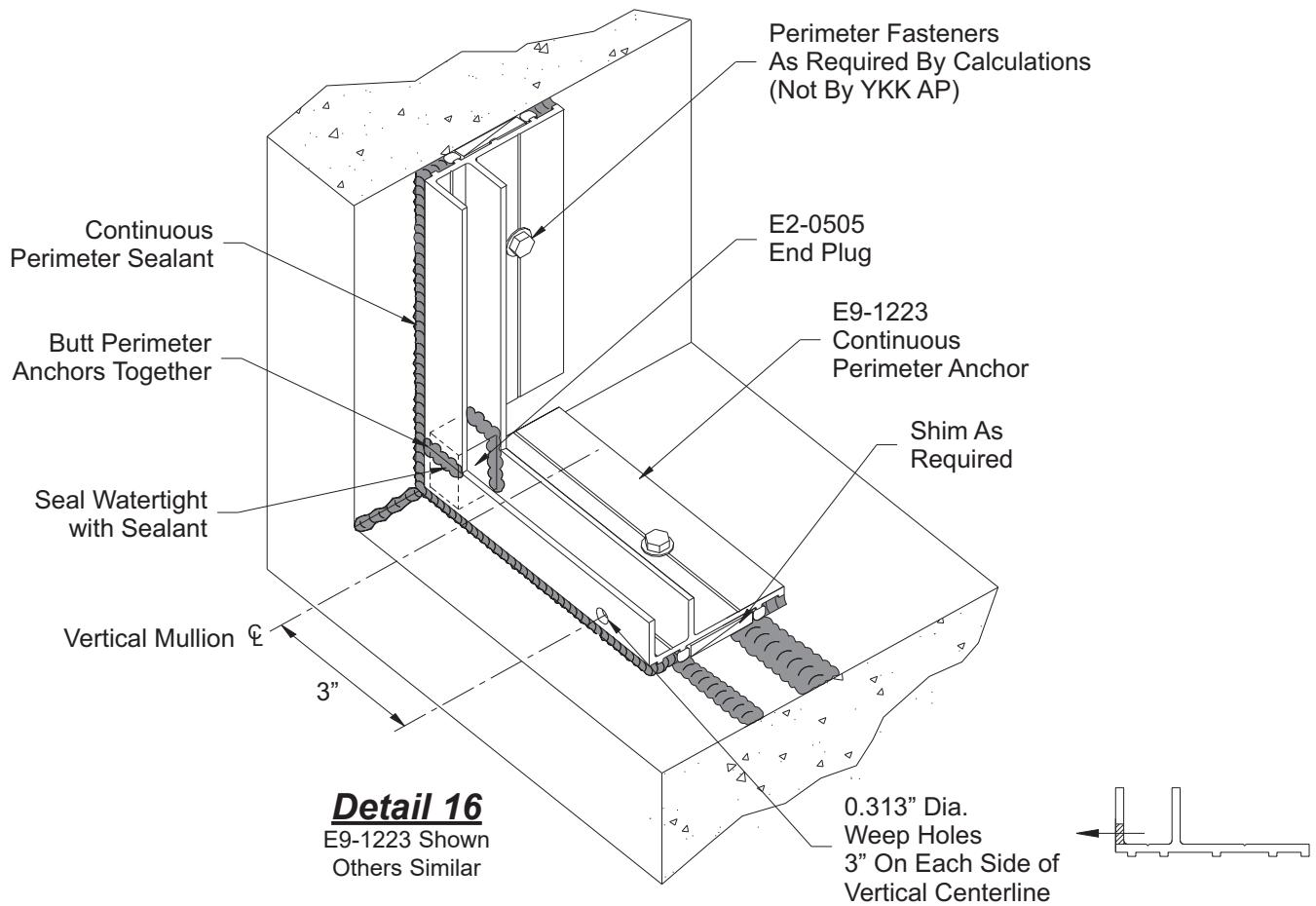

Detail 16
E9-1223 Shown
Others Similar

- Cut perimeter anchors to size:
Head and sill anchors stop 1/8" short of the structure.
Vertical jamb anchors butt in between head and sill anchors.
- Prepare structure for anchor attachment.
- Install perimeter anchors with appropriate perimeter fasteners. Refer to shop drawings or engineering calculations for type and spacing of fasteners. Shim as required to install anchors level.
- When splicing head and sill pieces together, leave 3/8" joint for expansion and install end plug, E2-0505, that has been buttered with sealant on the front, back, and bottom at the joint.
- Run continuous sealant along the perimeter between the anchors and the substrate.
- Seal corners of butted perimeter anchors watertight with sealant.
- Butter E2-0505 end plug with sealant on all sides that touch the anchors.
Then push end plug into place and tool excess sealant that comes through the cracks.
- Field drill 0.313" diameter weep holes in perimeter anchor (exterior face only) at sill only, 3" from center line of vertical on each side.

See **Detail 16**.

FRAME INSTALLATION

STEP 12 (When Required) JAMB/VERTICAL INSTALLATION WITH PERIMETER ANCHORS

- The notched ends of vertical mullions for 1" glazing leaves the interior of the mullion exposed and must be plugged prior to installation.
 - Install a small piece of backer rod into the notched out space directly behind the tongue at the top and bottom of the vertical mullions.
 - Push the backer rod into the opening at the face of the mullion.
 - Apply and tool sealant to seal off the opening made by the notch.
 - Install interior gasket, E2-0120, to jamb mullion (jamb side only) the full length of the mullion.
 - Position jamb into opening as shown below.
 - Seal the gap between the perimeter anchor and vertical glazing pocket(s) with sealant (one side for jambs – both sides for intermediate verticals).
 - Install temporary retainer clip, E1-3012 with E2-0265 at 2" long, at the top and bottom of the mullion.
 - Repeat this step for all jamb and vertical mullions.
- See **Detail 17**.

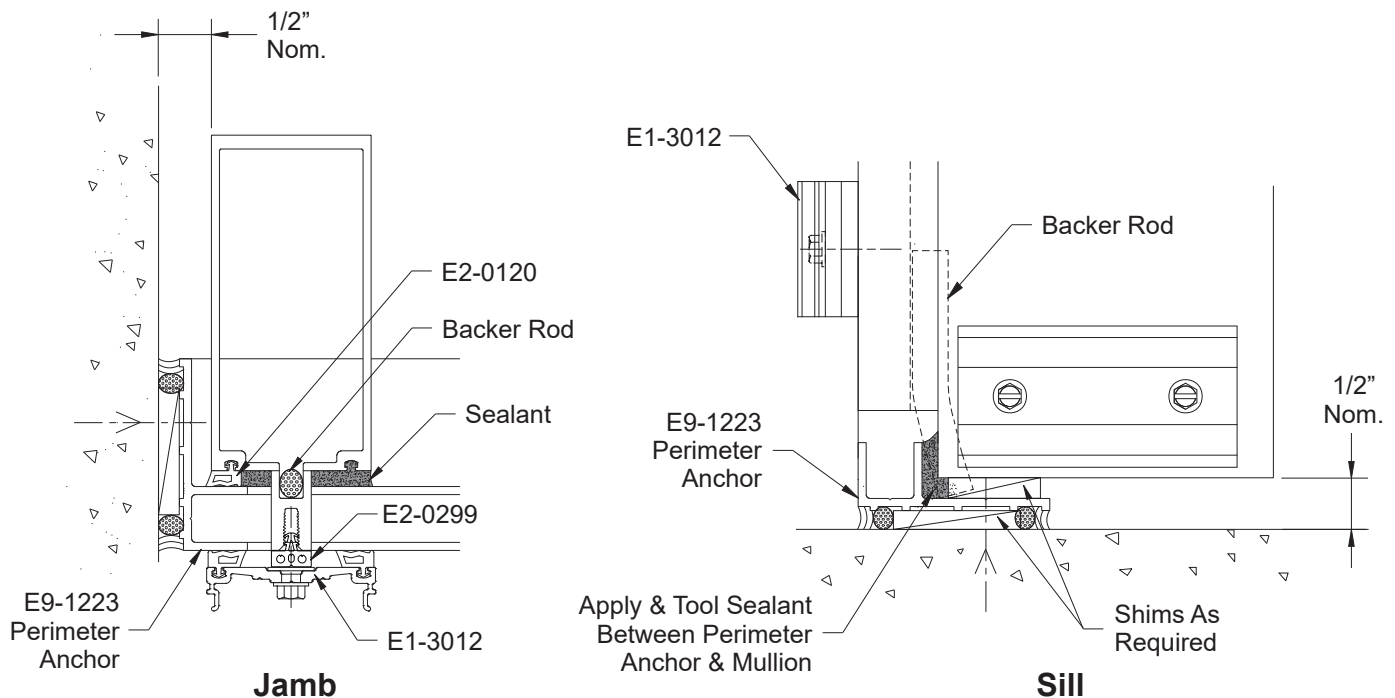

Detail 17
E9-1223 Shown
Others Similar

Sill Shown
Head Similar

FRAME INSTALLATION

**STEP 13 (Optional)
JAMB INSTALLATION WITH JAMB ANCHORS**

Optional jamb anchor clips, E1-3524 for 3-3/4" back depth and E1-3525 for 5-1/4" back depth, may be used with open back jamb members to reduce deflection at the jambs.

- Locate the jamb anchor locations on the structure according to approved shop drawings.
- Strike a plumb line the length of the frame height at the center line of the anchor fasteners.
- Provide anchor fasteners as per approved shop drawings or engineering calculations.
- Install the anchor fasteners as recommended by fastener manufacturer.
- Install the jamb mullions as instructed in the next step.

Note: Jamb anchor clips must be installed plumb and line up straight with each other.

See **Detail 18**.

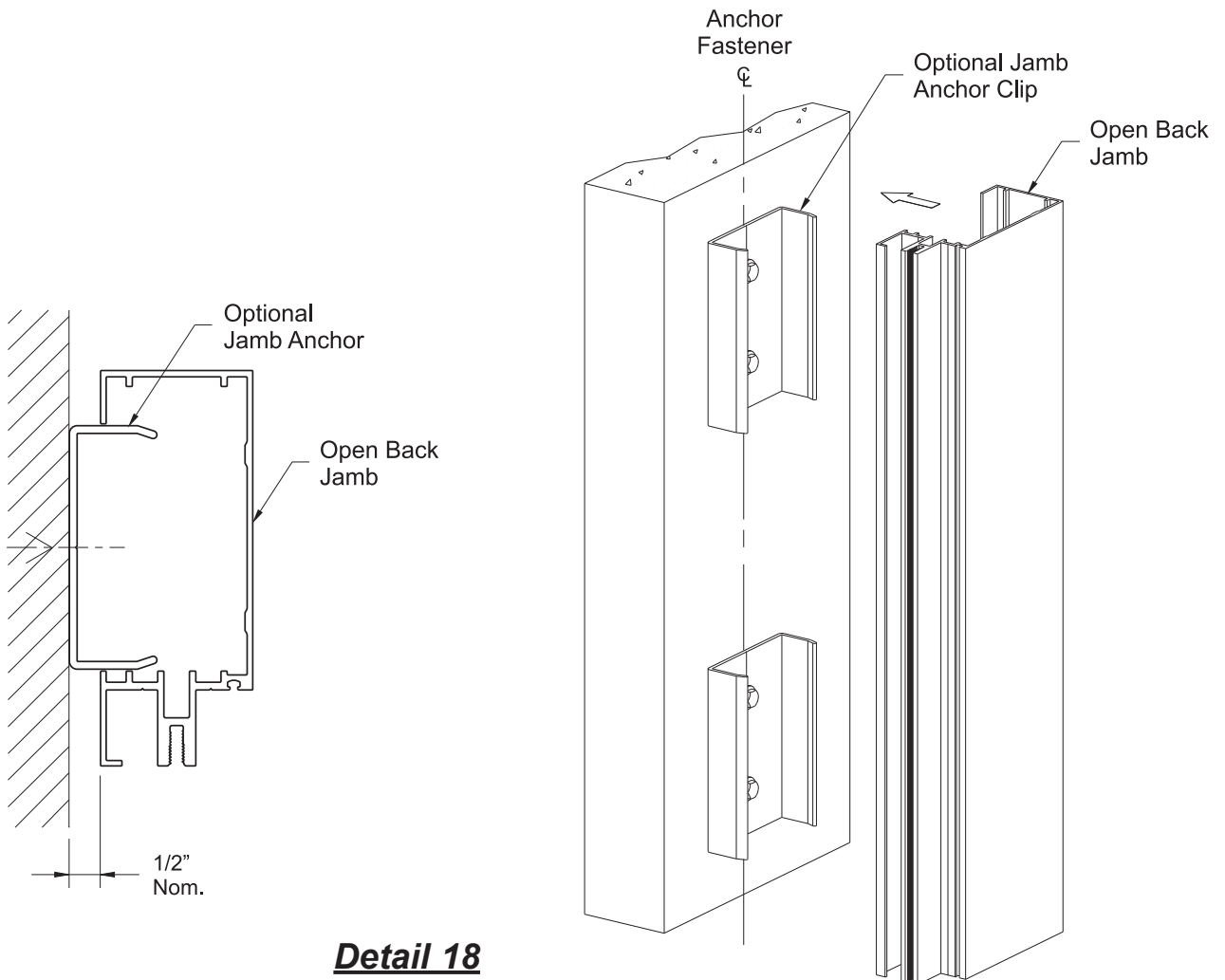

Detail 18

FRAME INSTALLATION

STEP 14 JAMB/VERTICAL INSTALLATION WITH MULLION END ANCHORS

- Clean all contact surfaces as recommended by sealant manufacturer.
 - Apply sealant into the screw raceway and along the front edge of the mullion at each end.
 - Prior to erecting verticals, install mullion end caps, E1-1286, at the top and bottom of the mullions with FC-1410 fasteners.
 - Seal all screw heads with sealant.
- See **Detail 19**.

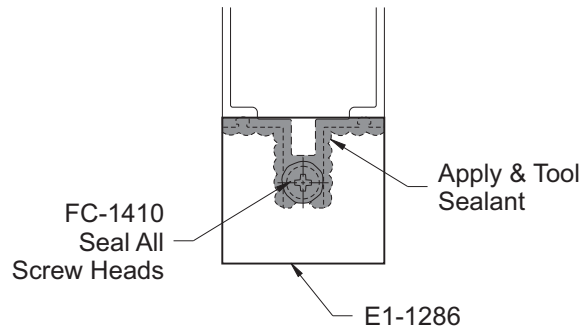

Detail 19

Standard 1" Shown
Others Similar

- Insert mullion "T" and "F" anchors into the top and bottom of the mullions before erecting them into the opening.
 - Erect and locate the jamb and vertical mullions and temporarily attach them to the structure. All mullions must be installed plumb and true.
 - Drill through the pre-drilled holes in "T", "F" and "J" anchors into the structure for the appropriate anchor fasteners according to approved shop drawings or engineering calculations.
- See **Detail 20**.

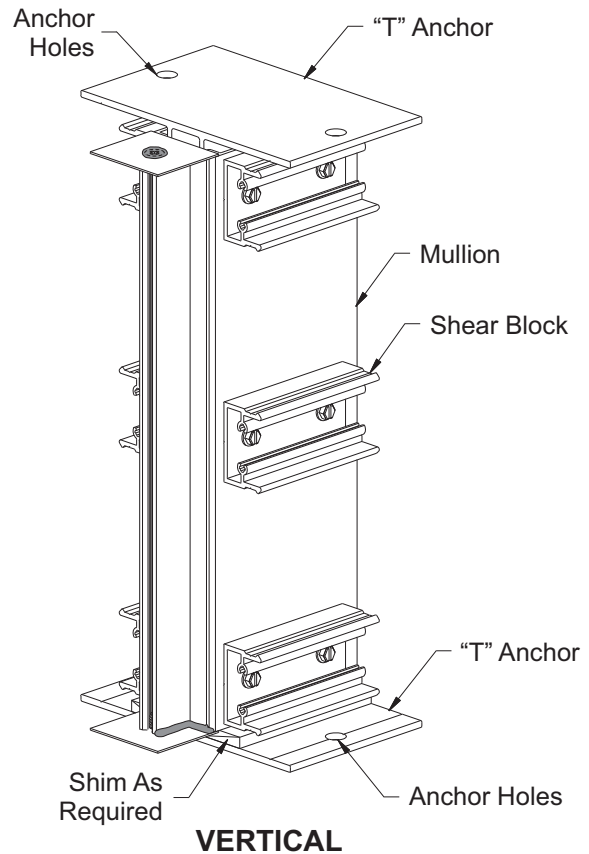
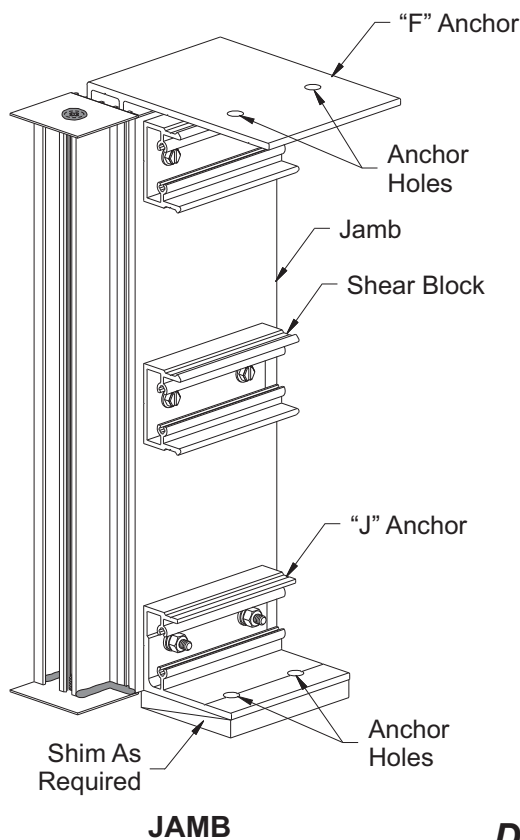

Detail 20

FRAME INSTALLATION

**STEP 14A
VERTICAL INSTALLATION
AT DOOR JAMB END ANCHORS**

The mullions at the door jambs are set directly upon the sill substrate without any shims and are sealed against the substrate. The anchors to be used at this location are specified by the approved shop drawings and or P.E. calculations.

-Locate the mullion anchor for the door jamb and install it to the substrate according to the approved shop drawings and P.E. calculations.

Note: if using an exposed fasteners shear block as a mullion anchor, check to ensure the sill shear block fasteners will not cause interference. Field modify the shear block anchor as required. See **Detail 22**.

-Clean all contact surfaces as recommended by sealant manufacturer.
-Set the mullion on the anchor, directly onto the sill substrate in a bed of sealant. Avoid using shims at this location. See **Detail 21**.

-Refer to the approved shop drawings for any additional fasteners required at anchor.
-Tool sealant at the bottom of the mullion at the sill substrate around the perimeter of the mullion. See **Detail 23**.

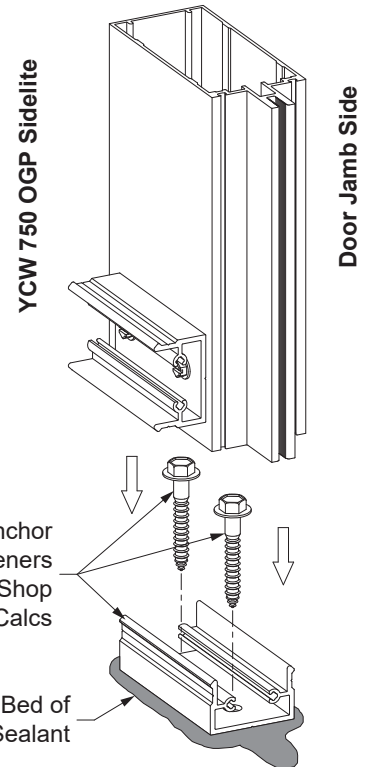

Detail 21

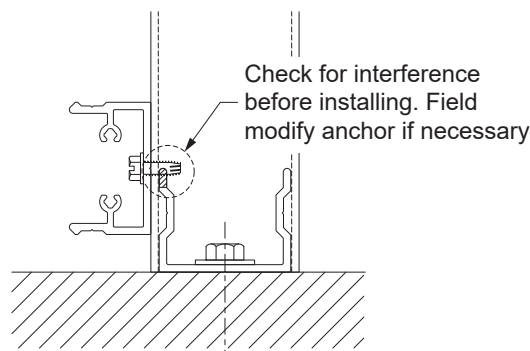

Detail 22

For Exposed Fasteners Shear Block Used as Anchor

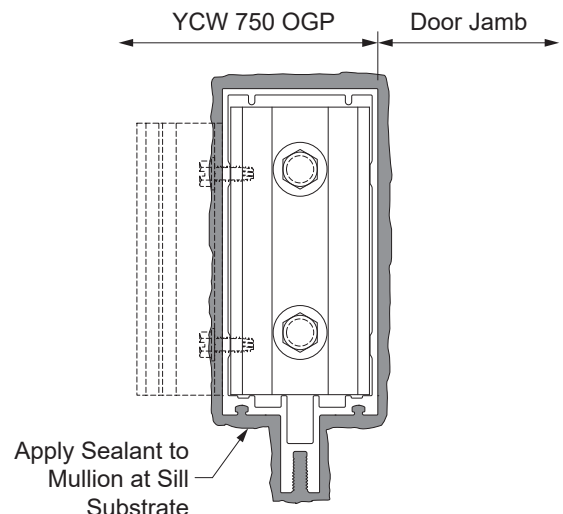

Detail 23

FRAME INSTALLATION

STEP 15
INSTALL WIND LOAD/DEAD LOAD ANCHORS

-Install steel wind load and dead load anchors. Anchor are normally template or line set before mullions are hung. Outstanding leg of anchor must be set at 90° to offset line. The back of the vertical mullion should set about 1" from the anchoring substrate.

-Torque all anchor bolts to 90 inch-pounds.

See **Detail 24**.

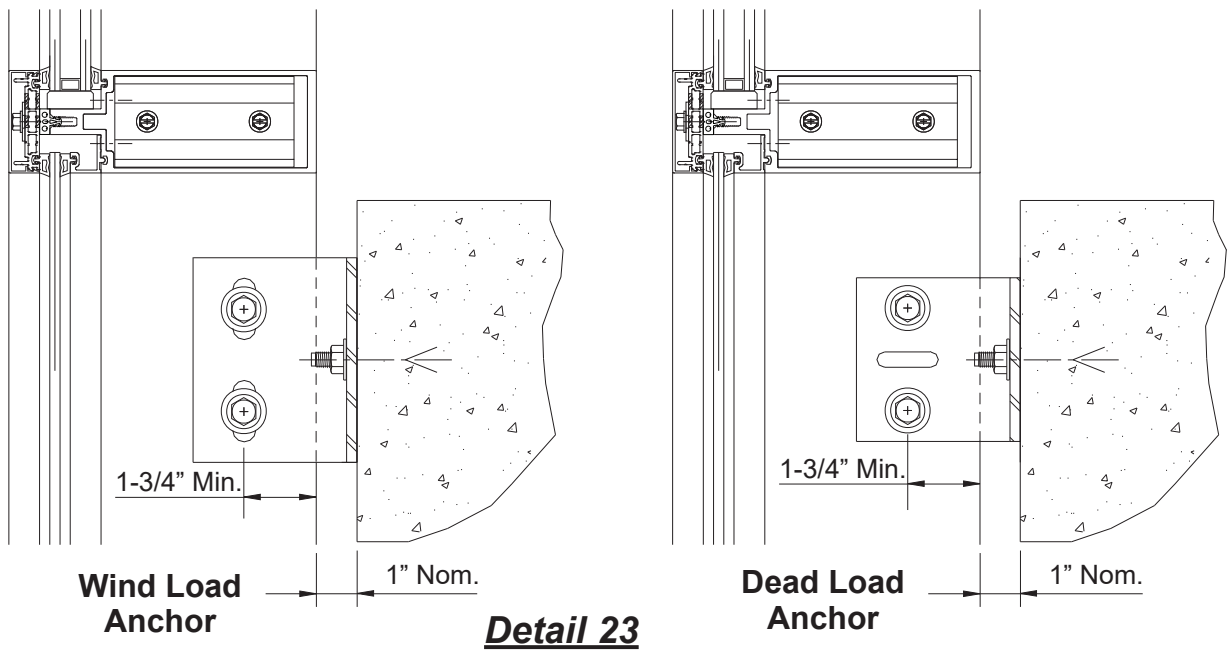

-Install, plumb, and align vertical mullions. Drill and install appropriate diameter anchor bolts per approved shop drawings or engineering calculations.

-Nylon slip pads, E3-0103, must be installed between mullion and anchors.

See **Detail 24**.

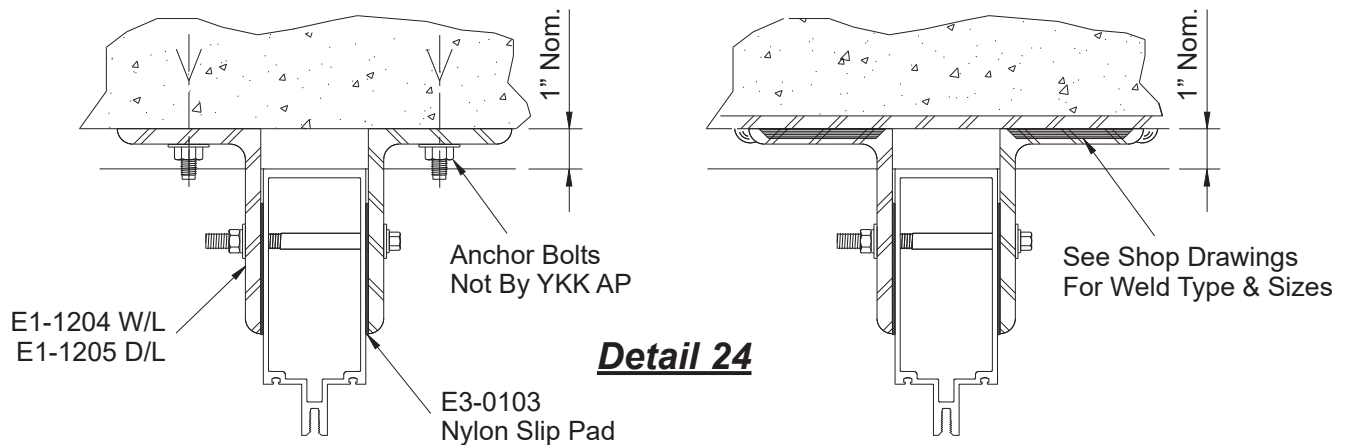

FRAME INSTALLATION

TYPICAL WIND LOAD ANCHOR

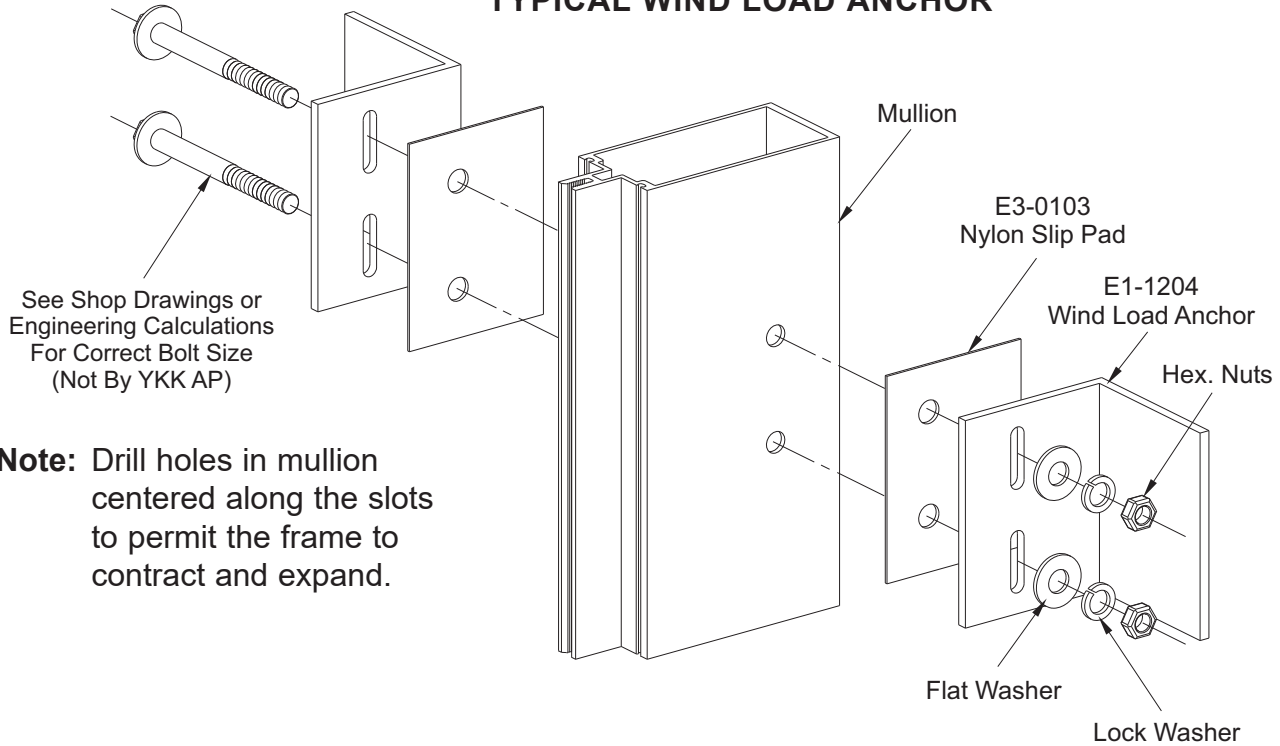

Detail 25

TYPICAL DEAD LOAD ANCHOR

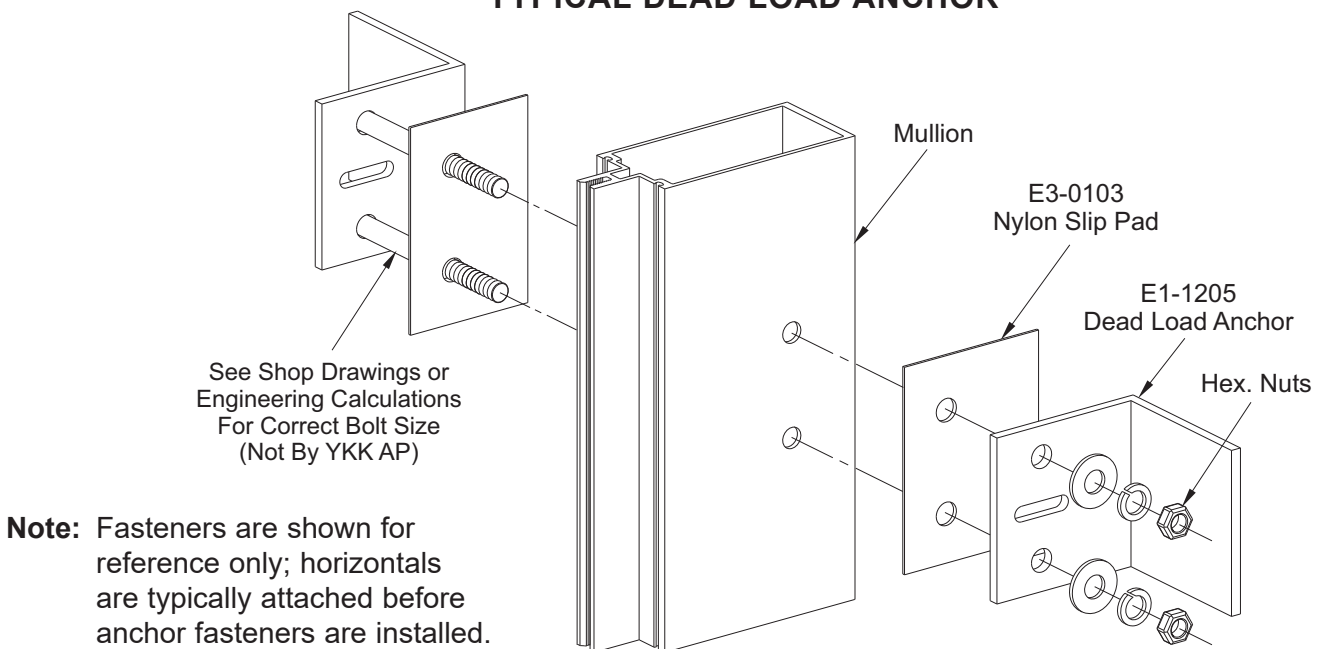

FRAME INSTALLATION

JAMB WIND LOAD ANCHOR

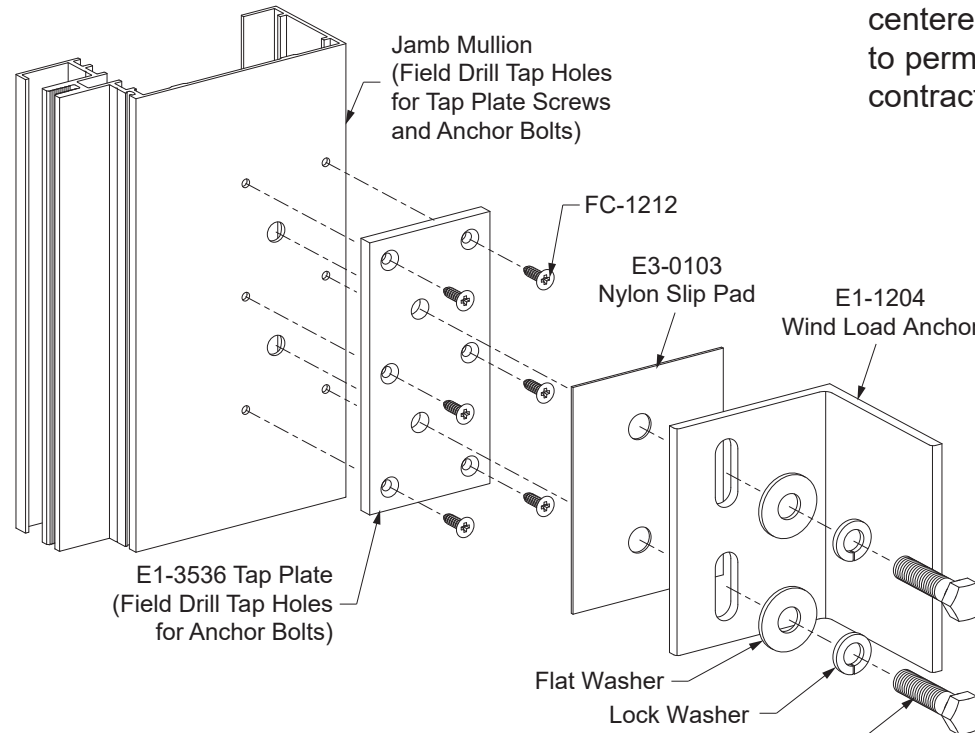

Note: Drill holes in mullion centered along the slots to permit the frame to contract and expand.

JAMB DEAD LOAD ANCHOR

Detail 25A

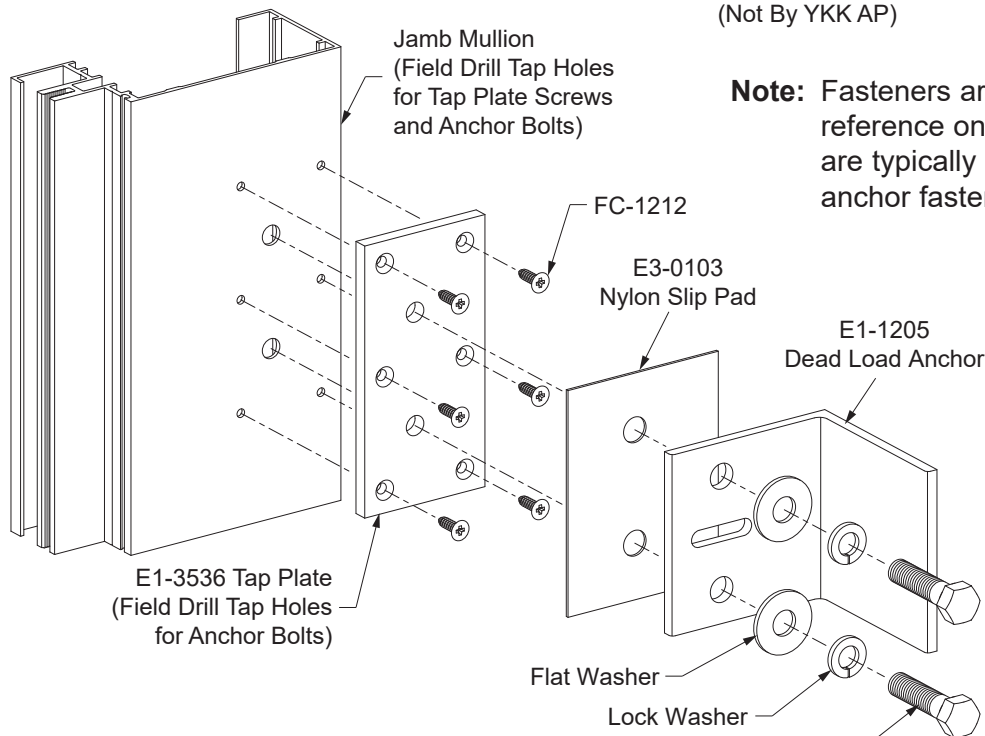

See Shop Drawings or Engineering Calculations For Correct Bolt Size (Not By YKK AP)

Note: Fasteners are shown for reference only; horizontals are typically attached before anchor fasteners are installed.

See Shop Drawings or Engineering Calculations For Correct Bolt Size (Not By YKK AP)

FRAME INSTALLATION

**STEP 16
ATTACH HORIZONTAL MEMBERS**

Note: Before applying any sealant, clean aluminum surfaces using cleaner and method approved by sealant manufacturer.

-Just prior to attaching the horizontal members to the vertical, apply sealant to the front of the shear block as shown.

Horizontals with Concealed Fasteners:

-Slide the horizontal members towards the vertical and attach them to the shear blocks at each end with two FC-1220 fasteners.

-Tool and wipe away any excess sealant at the vertical to horizontal joints.

See **Detail 26**.

CONCEALED FASTENERS

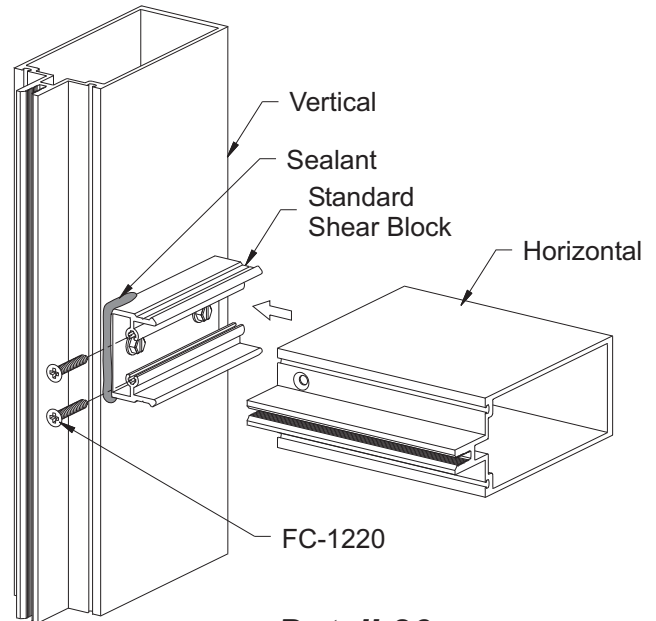

Detail 26

Horizontals with Exposed Fasteners:

-Slide and align the horizontal members towards the vertical and transfer the hole locations on top of the horizontal to the shear block.

-Remove the horizontal and drill a 0.189" dia. (#12 bit) hole at each hole location.

-Slide the horizontal back against the vertical and attach it to the shear block with two FC-1212 fasteners at each end.

-Tool and wipe away any excess sealant at the vertical to horizontal joints.

See **Detail 27**.

EXPOSED FASTENERS

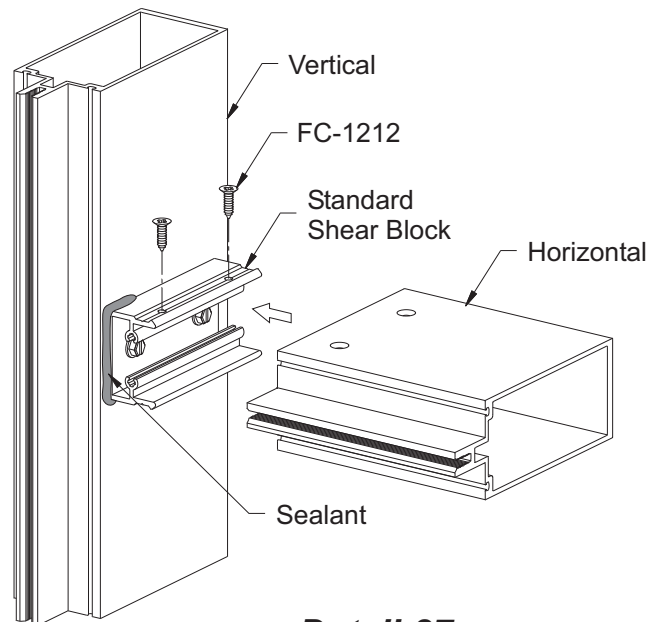

Detail 27

FRAME INSTALLATION

STEP 16 (Continued)
ATTACH HORIZONTAL MEMBERS

Open Back Intermediate Horizontals:

- Just prior to attaching the horizontal members to the vertical, apply sealant to the front of the shear block as shown below.
 - Lower the horizontal down onto the shear block. Make sure the horizontal and vertical glazing pockets are flush.
 - Attach the horizontal to the shear block at the face of the horizontal with two FC-1220 fasteners at each end.
 - Tool and wipe away any excess sealant at the vertical to horizontal joints.
 - Snap on the mullion flush filler.
- See **Detail 28**.

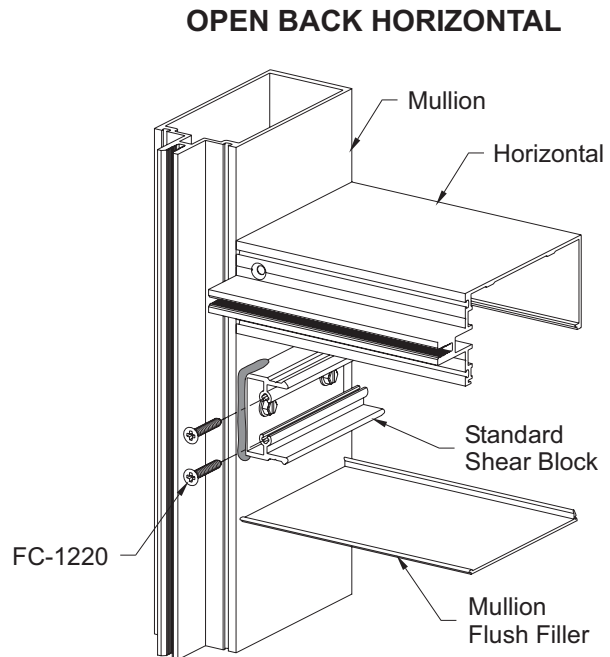

Detail 28

Open Back Head & Sill Members at End Bays:

- To clear the mullions at end bays, shear blocks must be pre-attached to the head and sill members through the face of the mullion with FC-1220 fasteners.
 - Position the head/sill members into place and attach the shear blocks to the verticals with two HF-2510-W1 fasteners per block.
 - Provide anchor fasteners per approved shop drawings or engineering calculations.
 - Install the anchor fasteners as recommended by fastener manufacturer.
 - Snap on the mullion flush filler.
- See **Detail 29**.

OPEN BACK HEAD/SILL AT END BAY

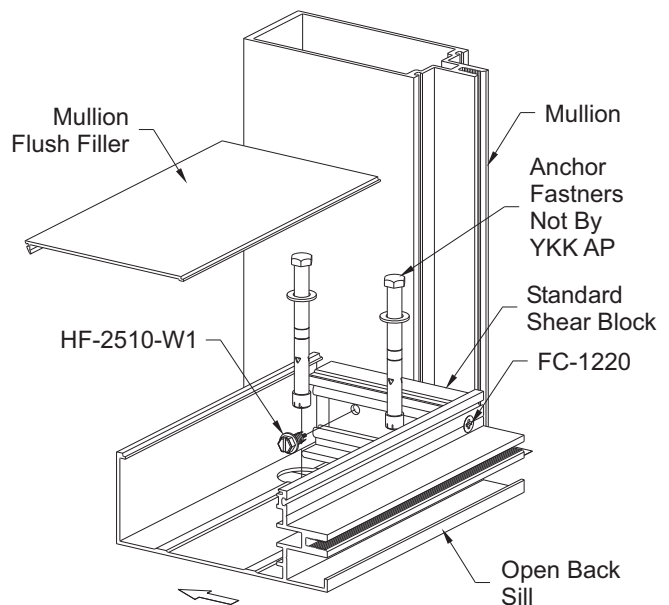

Detail 29

Sill Shown, Head Similar

Caution: A solid shim must be placed under the vertical mullion to transfer glazing dead loads to the foundation.

FRAME INSTALLATION

**STEP 16 (Continued)
ATTACH HORIZONTAL MEMBERS**

Optional Incidental Water Head Members:

- End anchors must be installed before attaching incidental water heads; install the anchor bolts according to manufacturer's recommendations.
 - Install a weep baffle, E2-0099, directly behind each weep hole. Dab a small amount of sealant on the bottom of the weep baffle to secure it.
 - Just prior to installing the the incidental water head members, apply sealant to the underside of the shear clip where it meets the vertical.
 - Incidental water head members must be joggled into place:
 - Tilt the head member towards the exterior and engage the back of the head with the back of the shear clip. Rotate the head into place and push it forward to properly seat the head member on the shear clip.
 - Attach the head member to the shear clip with two PC-1208 fasteners per clip.
 - Apply and tool sealant to the head to vertical intersection at each end as shown in **Detail 31**.
 - Snap on the mullion flush filler.
- See **Detail 30**.

Tubular Head & Sill Members:

- Mullion end anchors must be installed before head and sill members are attached.
- Provide anchor fasteners as per approved shop drawings or engineering calculations.
- Install the anchor fasteners as recommended by fastener manufacturer. See **Detail 32**.
- Clean, seal, and attach head and sill members as previously shown on **Page-29**.

Caution: A solid shim **must** be placed under the vertical mullion to transfer glazing dead loads to the foundation.

INCIDENTAL WATER HEAD

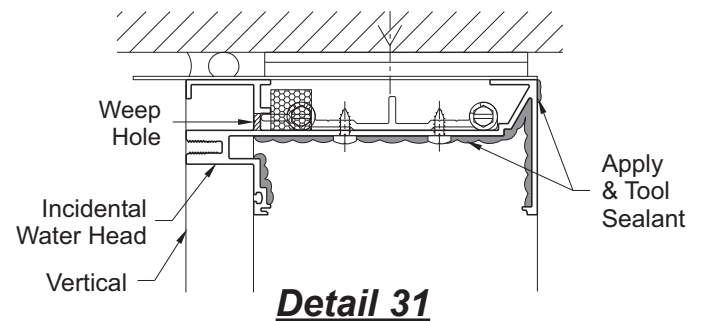
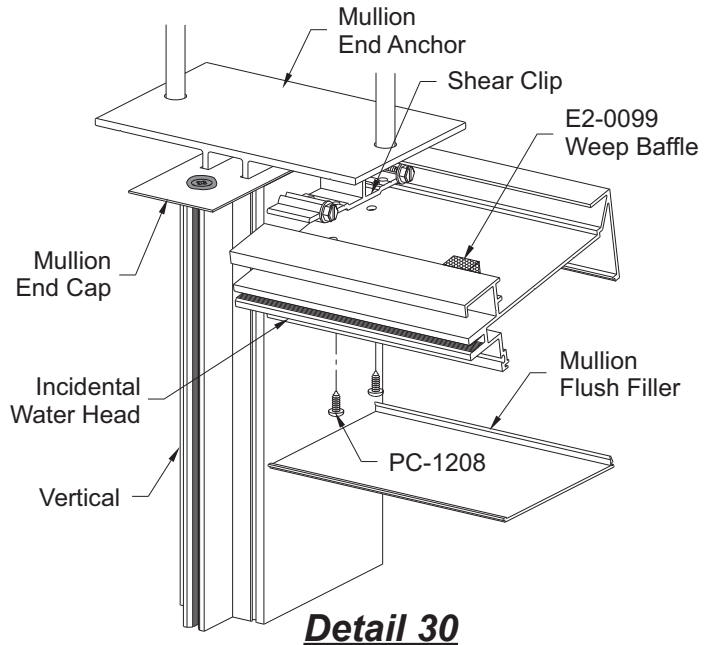

TUBULAR HEAD/SILL

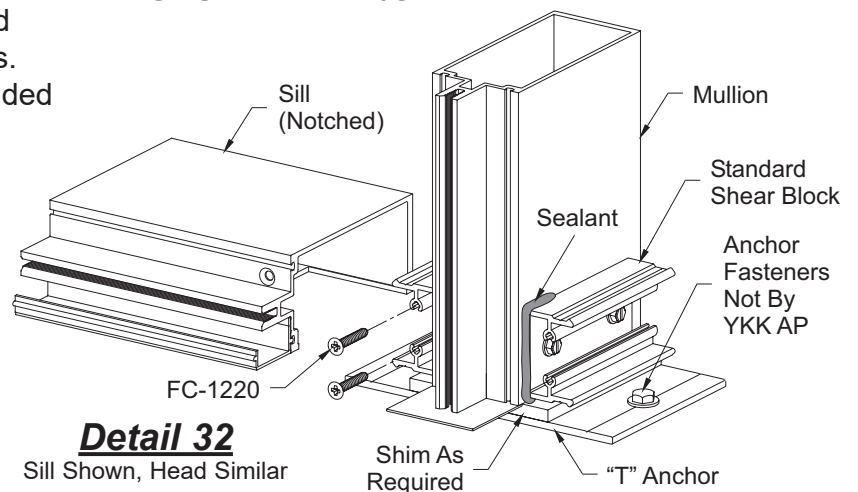

FRAME INSTALLATION

STEP 16 (Continued)
ATTACH HORIZONTAL MEMBERS

TUBULAR HORIZONTALS AT END BAYS

For Tubular Horizontals at End Bays (E-Slot):

- Slide the horizontal into place from the interior; the shear blocks should easily pass through the E-Slots at the ends of the horizontal. Make sure that the glazing pockets are flush.
- Attach the horizontal to the shear block at each end with FC-1212 fasteners as previously shown for horizontals with exposed fasteners. See **Detail 33**.

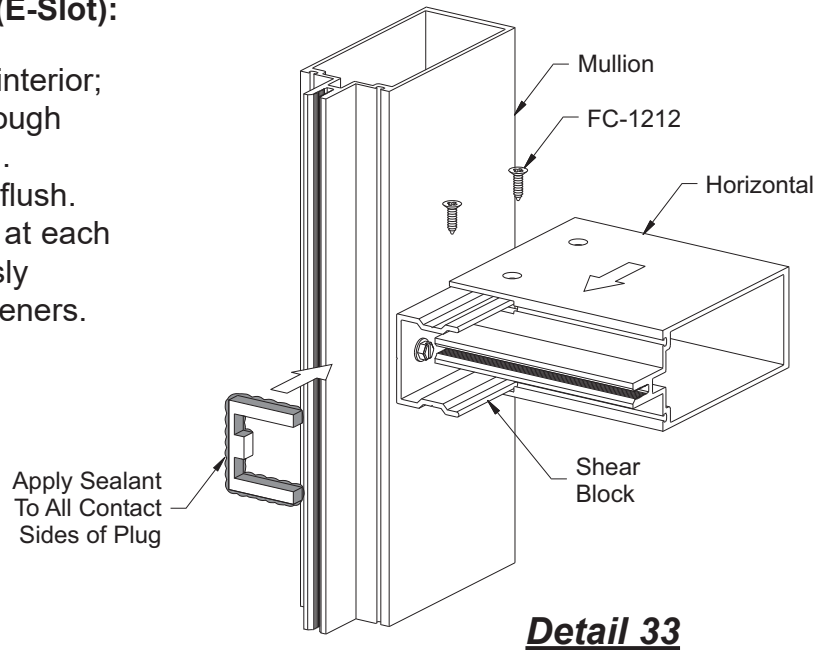

Detail 33

- Apply sealant to all contact sides of the E-Slot plug, E2-0123.
- Insert the E-Slot plug into place and press it firmly against the shear blocks.
- Cover the entire slot with sealant and tool the sealant to ensure a watertight seal. See **Detail 34**.

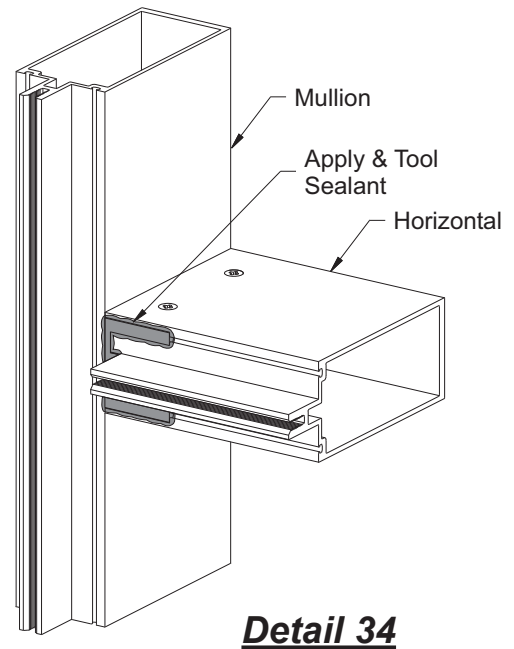

Detail 34

FRAME INSTALLATION

**STEP 17
INSTALL DOOR SUBFRAMES**

Refer to the **Entrances Installation Manual** for assembly of the door subframes. These subframes are typically glazed into the curtain wall framing at the jambs, and set directly upon the sill substrate without any shims. The subframe members are determined by the approved shop drawings.

-Clean all sealant contact surfaces as recommended by the sealant manufacturer.

-Install the jamb subframe onto the mullion with fasteners according to the approved shop drawings and/or P.E. calculations, setting the subframe jambs in beds of sealant as shown in **Detail 35**.

-Apply and tool sealant to the bottom of the jamb subframe as shown in **Detail 36**.

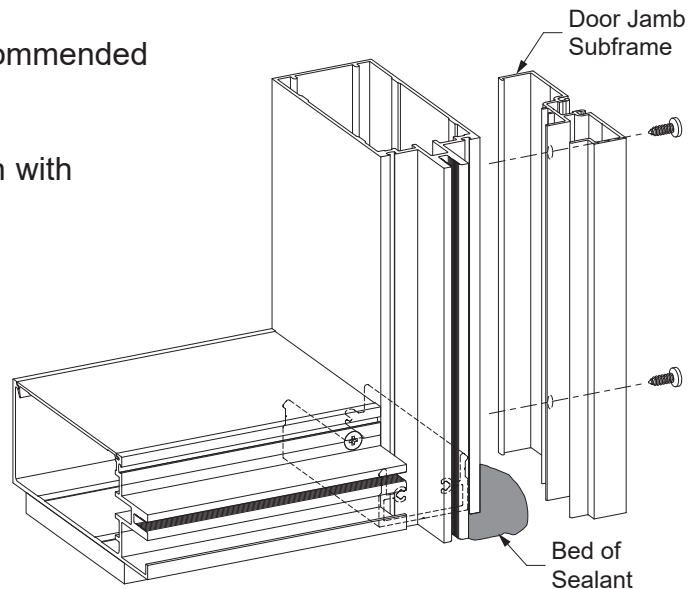

Detail 35

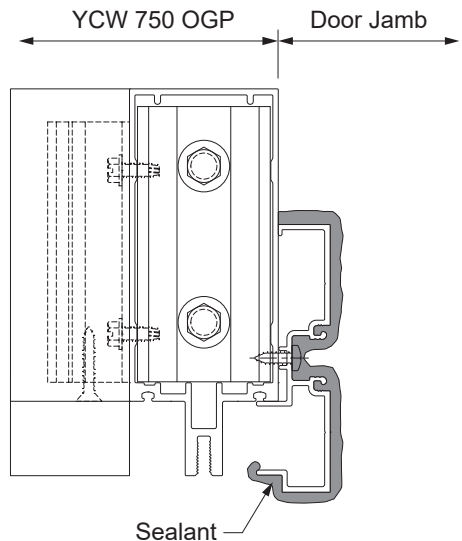

Detail 36

FRAME INSTALLATION

STEP 17a

APPLY PERIMETER SEALANT WHEN USING STANDARD JAMB MEMBERS

- Clean the area around the perimeter of the frame with cleaner and method approved by sealant manufacturer.
 - Push in backer rod between the perimeter of the frame and the substrate about 1/4".
 - Apply sealant to the perimeter of the frame.
 - Tool the sealant to ensure a water tight joint.
- See **Detail 37a**.

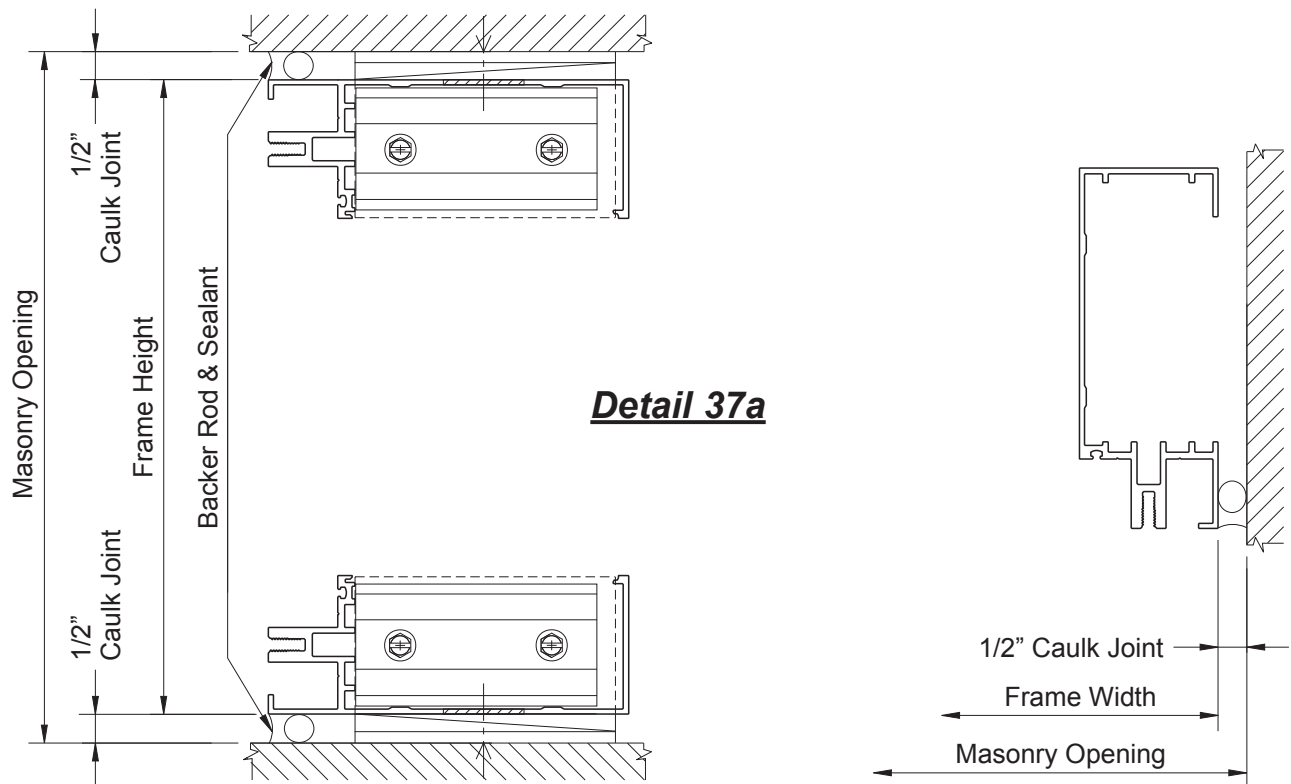

FRAME INSTALLATION

STEP 17b

APPLY PERIMETER SEALANT WHEN USING OPTIONAL JAMB MEMBERS

- Clean the area around the perimeter of the frame with cleaner and method approved by sealant manufacturer.
- Push in backer rod between the perimeter of the frame and the substrate about 1/4".
- Apply sealant to the perimeter of the frame.
- Tool the sealant to ensure a water tight joint.
- Perimeter pocket fillers (E9-1253) are to be secured to the framing members with PC-1010 fasteners at 24" O.C.

See **Detail 37b**.

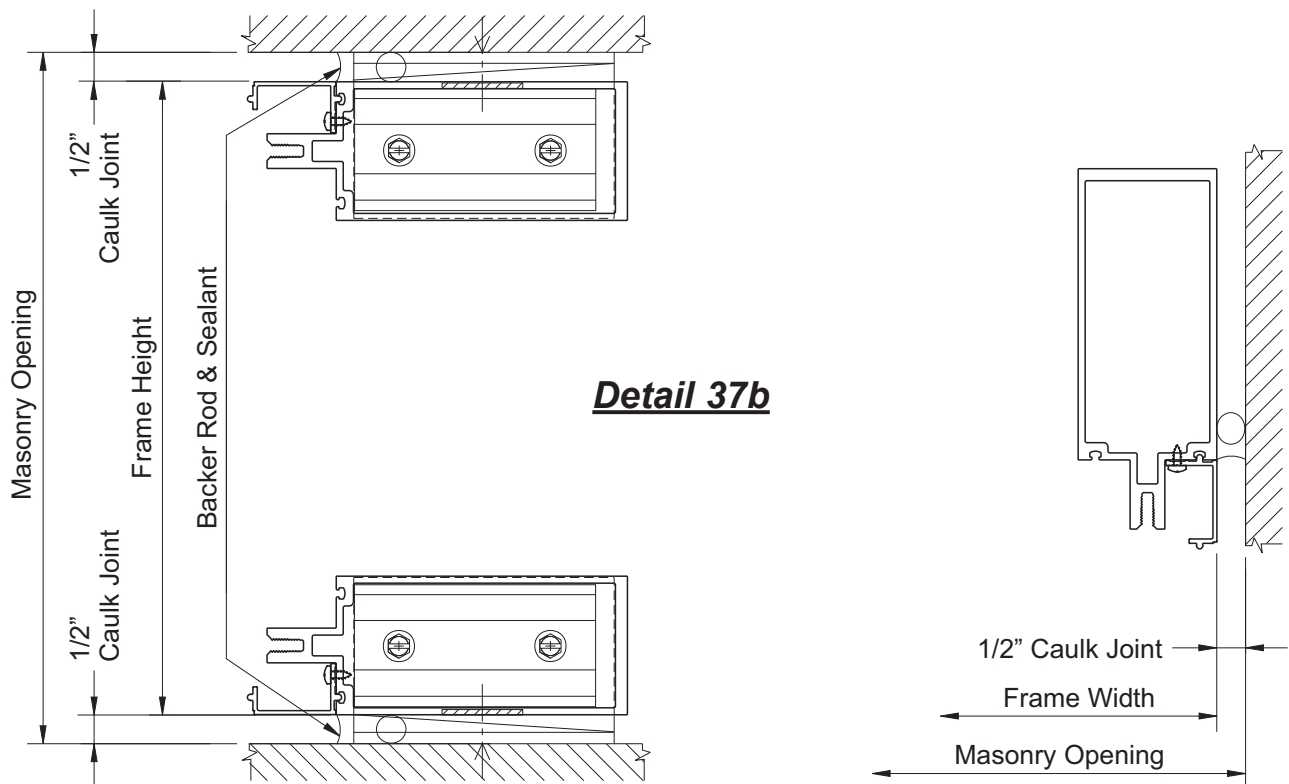

FRAME INSTALLATION

STEP 17c (Optional) INSTALL PVC PERIMETER FILLER

-For polyamide pressure plate application, the PVC perimeter filler (E3-3665, cut to mullion length minus 1/16") must be installed in all perimeter conditions before the pressure plates are installed.

-Apply a thin strip of silicone sealant into the reglet on the jamb mullion.

Note: Too much silicone will prevent engagement of the perimeter filler.

-Center and snap the perimeter filler and tap into place.

See **Detail 37c**.

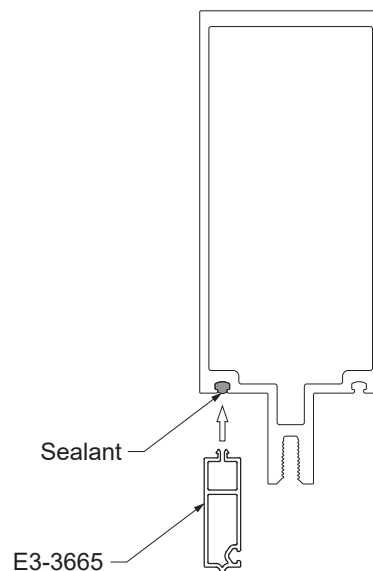

Detail 37c

FRAME INSTALLATION

**STEP 17d
ADD THERMAL ISOLATOR**

-Install the E2-0265 thermal isolator cut to the full length of the mullion.
See **Detail 37d**.

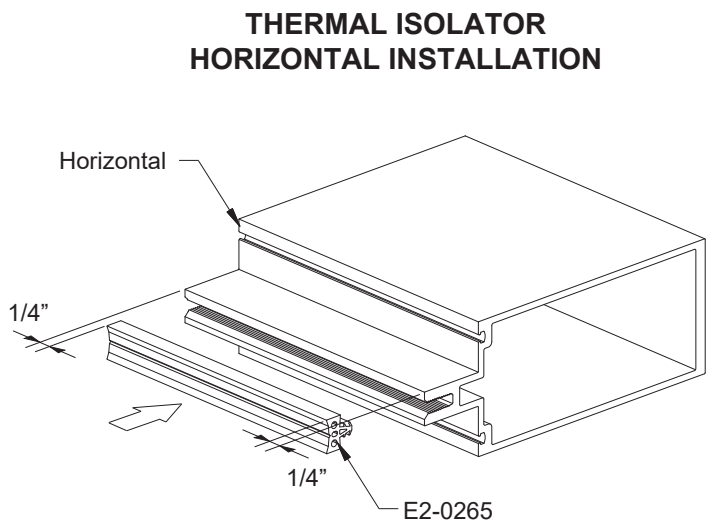
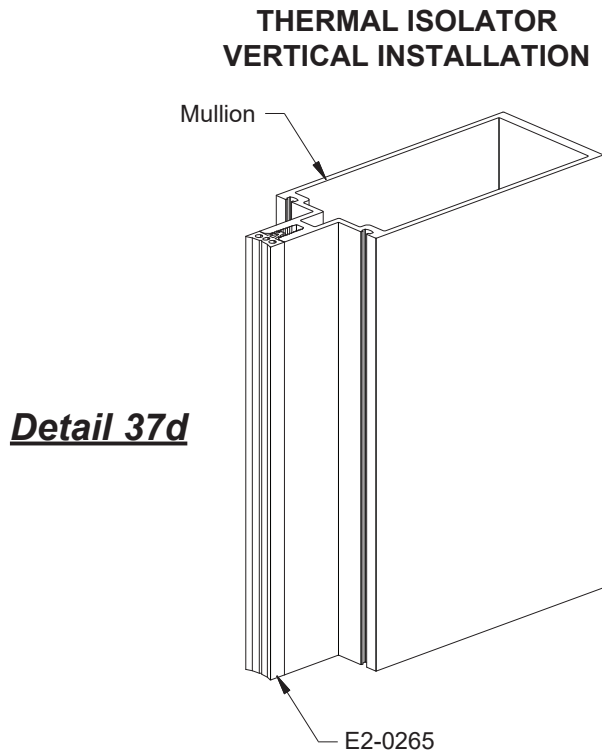

-Cut the thermal isolator to DLO minus(-) 1/2" and center.
-Install the thermal isolator into the horizontals, leaving 1/4" at each end for sealant at joint plugs.
See **Detail 37e**.

Note:
-Thermal isolators can be applied in the shop prior to assembly and erection.

Detail 37e

FRAME INSTALLATION

STEP 18
INSTALL JOINT PLUGS

The tongue of each head, horizontal and sill must be sealed to the tongue of the vertical and jamb mullions at each end with E2-0102 joint plugs.

For Open Back Sill Members:

- Just prior to installing joint plugs, clean the area around the intersection of the vertical and the sill member with an approved cleaner.
- Apply and tool sealant to the joint where the sill member meets the vertical and along the joint between the mullion end cap and the perimeter leg of the sill member.

See **Detail 38**.

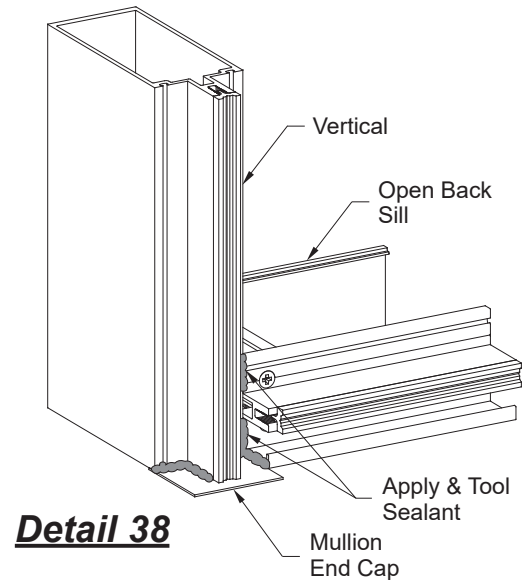

Detail 38

- Clean the area around the mullion tongue ends with an approved cleaner.
- Apply and tool sealant to the joint where the horizontal meets the vertical.
- Apply sealant to the three contact sides of the joint plug.
- Install joint plug as shown with the long leg of the joint plug against the vertical tongue.
- Press the joint plug firmly against the face of the mullion.
- Tool the sealant to ensure a watertight seal.
- Seal all exposed screw heads on the face of the mullion.

See **Detail 39**.

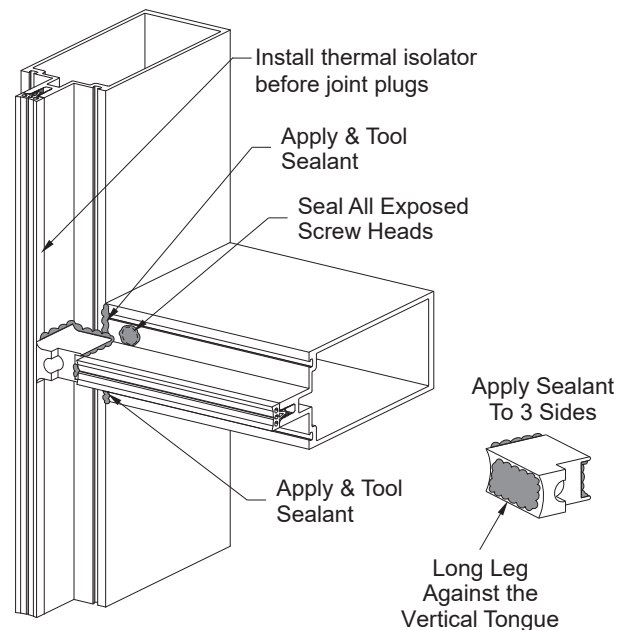

Detail 39

Int. Horizontal Shown
Head & Sill Similar

GLAZING

**STEP 19 (Optional)
INSTALL GLAZING ADAPTORS**

Note: 1/4" glazing adaptor, E9-1220 shown
1/2" glazing adaptor, E9-1232 similar.

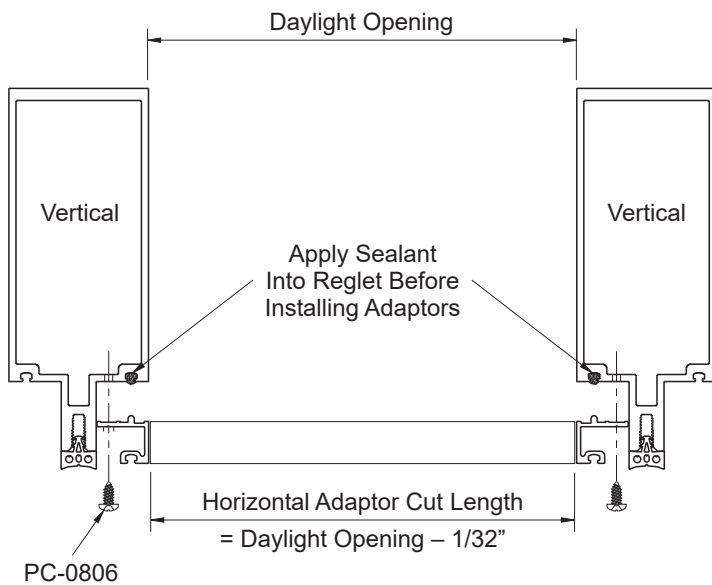

Detail 40

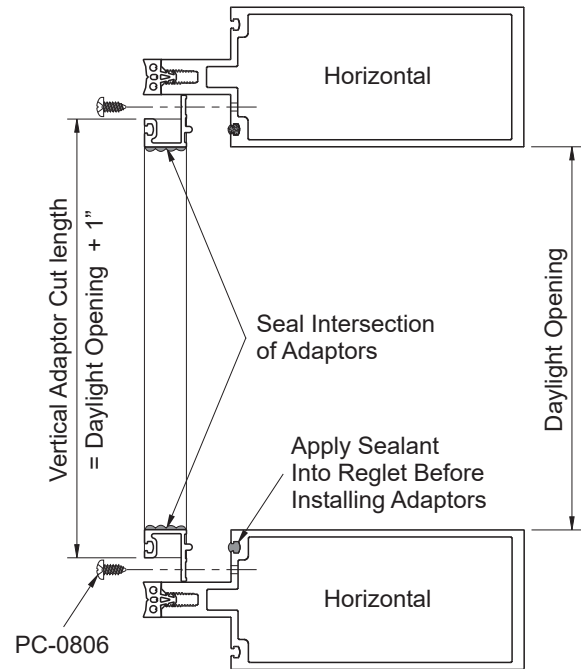

-Cut glazing adaptors to:

Vertical Cut Length = D.L.O. plus(+) 1".

Horizontal Cut Length = D.L.O. minus(-) 1/32".

- Pre-drill each adaptor along the "V"-groove with 0.189" dia. holes 2" from each end and 24" O.C.
- Dry fit adaptors and match drill 0.141" dia. holes (drill #28) on the mullion to receive PC-0806 fasteners.
- Clean the area around the mullion glazing reglet and the glazing adaptor with a cleaner approved by the sealant manufacturer.
- Apply sealant into the glazing reglet of the mullion and the ends of the horizontal adaptors.
- Install the adaptors with PC-0806 screws at each hole location. Install the vertical adaptors first; make sure they are centered along the day light opening.
- Tool sealant at all adaptor intersections and seal all screw heads.

See **Detail 40 & 41**.

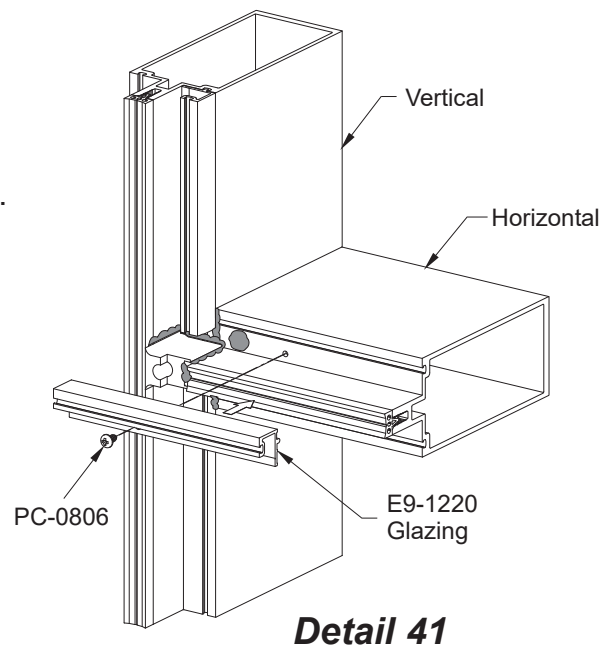

Detail 41

GLAZING

STEP 20 INSTALL INTERIOR GLAZING GASKETS

- Cut interior glazing gaskets to size:
 - Vertical Gasket = Daylight Opening + 1-1/2".
 - Horizontal Gasket = Daylight Opening + 1/4" per each foot of opening width.
- Install vertical gaskets first, centered along the daylight opening.
- Install horizontal glazing gaskets next.
 - Insert the glazing gasket into the reglet at each end first.
 - Snap the rest of the glazing gasket into the reglet starting at the center and work towards each end.

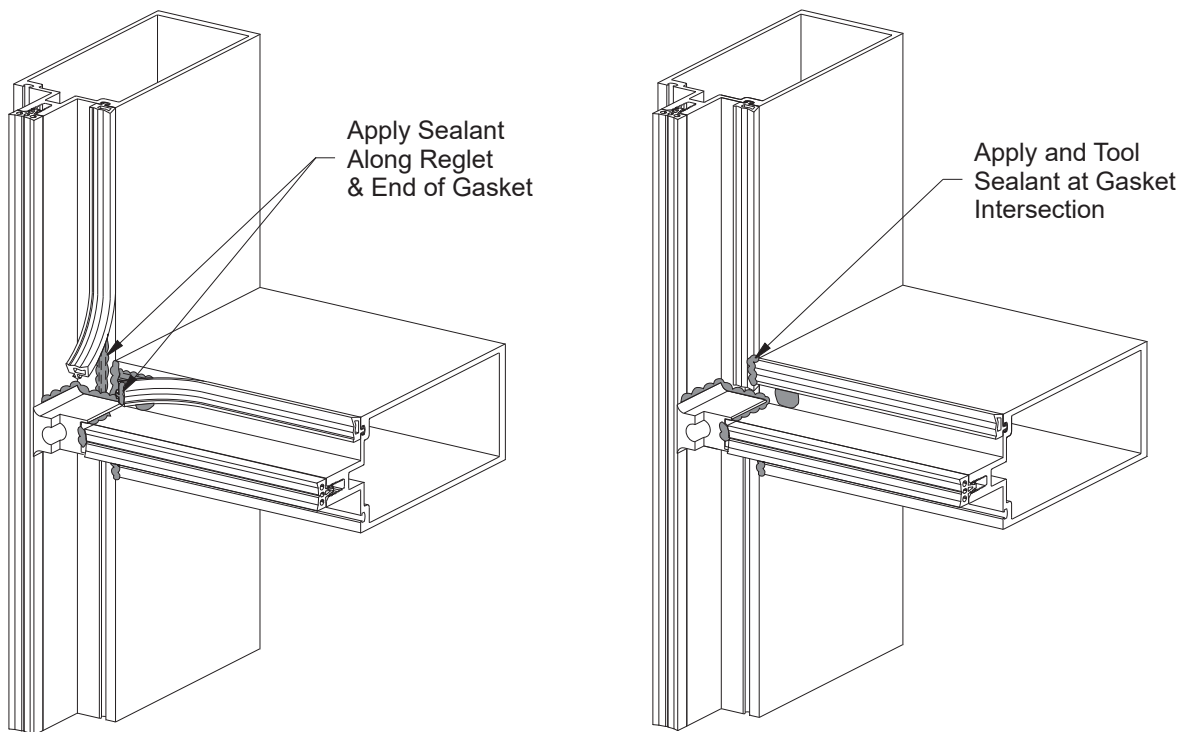

Detail 42

- Pull the last 3" of each gasket away from the reglet.
- With gasket end held out of the way, run a 2-3" bead of sealant into the reglet at the ends.
- Apply sealant at the ends of the horizontal gaskets.
- Reinsert the ends of the gaskets pressing them firmly against the face of the mullions.
- Apply and tool sealant at the intersection of the vertical and horizontal gaskets.

See **Detail 42**.

GLAZING

**STEP 21
INSTALL SETTING & SIDE BLOCKS**

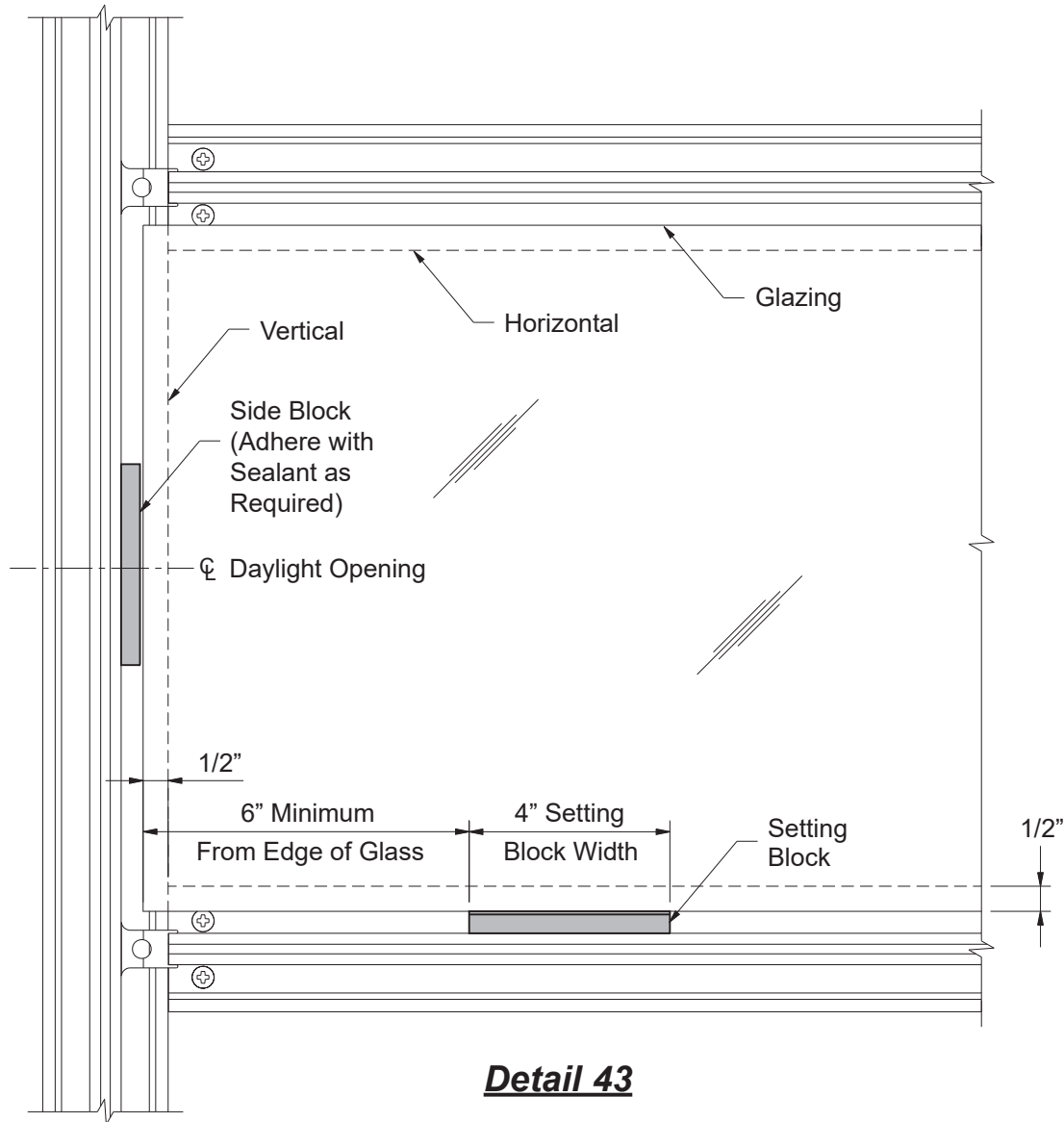

Detail 43

- Install setting blocks, E2-0104 (adhere with sealant) for 1" glazing or E2-0112 for 1/4" glazing, at 1/4 points of D.L.O. or minimum of 6" from edge of glass, whichever is greater. Consult YKK AP for setting block requirements on units that exceed 60" x 90" or 40 sq. ft.
- Install E2-0105 side blocks centered along the daylight opening on both sides of glazing material. See **Detail 43**.

GLAZING

**STEP 22
INSTALL EXTERIOR GLAZING GASKETS**

- Preload exterior vertical glazing gaskets to the same length as the vertical pressure plates.
- Preload exterior horizontal glazing gaskets to daylight opening plus 1/4" per foot of opening width.
- Install vertical glazing gaskets onto the vertical pressure plates.
- Install horizontal gaskets by pushing each end into the reglet of the pressure plate. Next press center of gasket into reglet; then push gasket into reglet working from center towards the ends.

Caution: Do not stretch the gaskets.

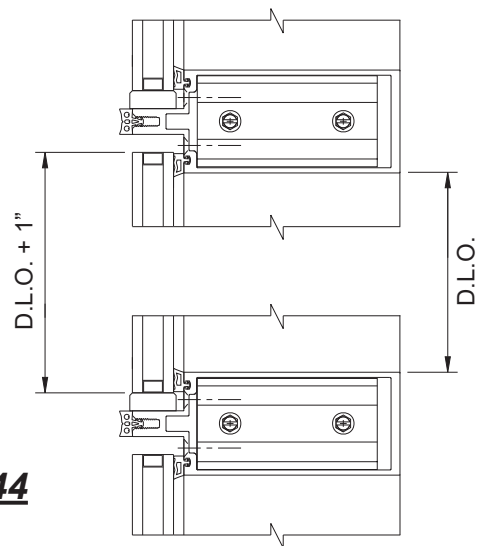
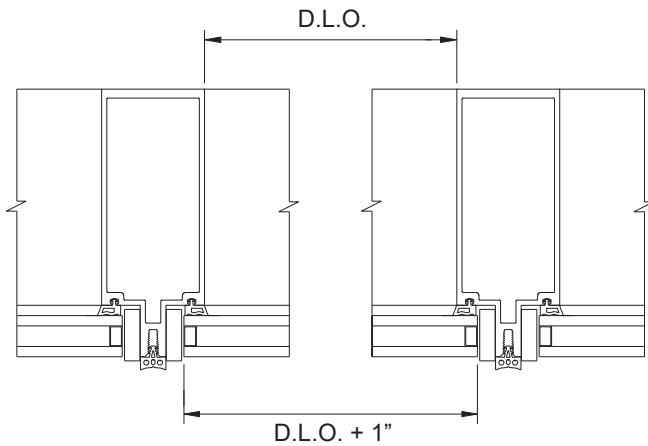

Detail 44

**STEP 23
INSTALL GLASS**

Glass and Spandrel Size = Daylight Opening + 1" Horizontally and Vertically.

- As each lite is installed, attach a temporary retaining clip, E1-3012, in the middle of each horizontal and 4" from glass edge at each end using HD-2516-W3-SS fasteners.
- Reuse the temporary retaining clips.
- Apply sealant to the face of the joint plugs just prior to installing vertical pressure plates. Do not allow sealant to skim over prior to installing pressure plates.

Note: Sealant must form a complete seal between the exterior gasket, pressure plate, thermal isolator, and the joint plug.

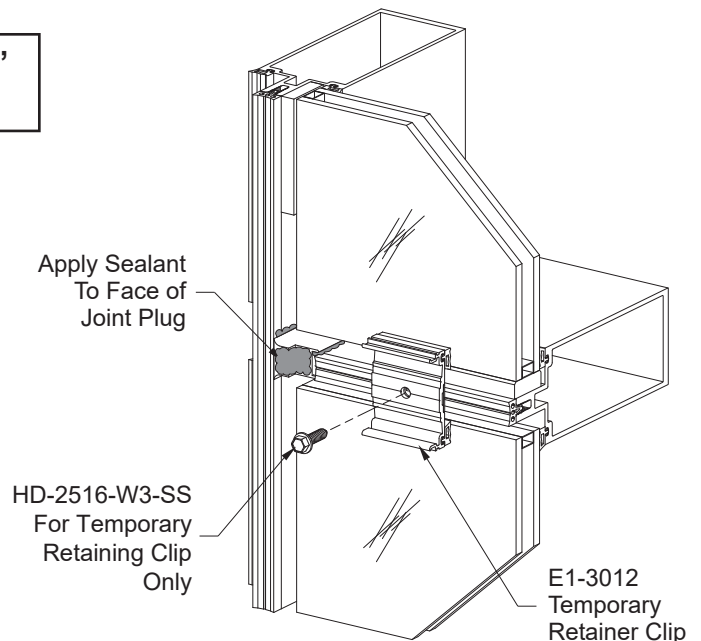

Detail 45

See **Detail 44 & 45**.

GLAZING

STEP 24

INSTALL VERTICAL PRESSURE PLATES AND VERTICAL FACE COVERS

-Pressure plate stock lengths are factory punched with 0.281" diameter holes at 8" O.C. maximum. After cutting, additional holes may be required to have screws 1-1/2" from each end. See **Detail 49** on **Page 44**.

-Working from the bottom up, install vertical pressure plates using HD-2520-W3-SS screws and FW-2500-SS fender washers. Initially torque screws to 30 inch-pounds with a speed wrench or torque limiting screw gun. -Then, torque all vertical pressure plate screws to 40 to 45 inch-pounds.

-Snap on exterior vertical face covers using a mallet and a clean scrap piece of lumber. Start at one end and work down the mullion. Avoid hitting the center of the cover. See **Detail 46**.

-Fasten the cover to the pressure plate with one PF-0808-SS screw at the bottom of each vertical cover. See **Detail 47**.

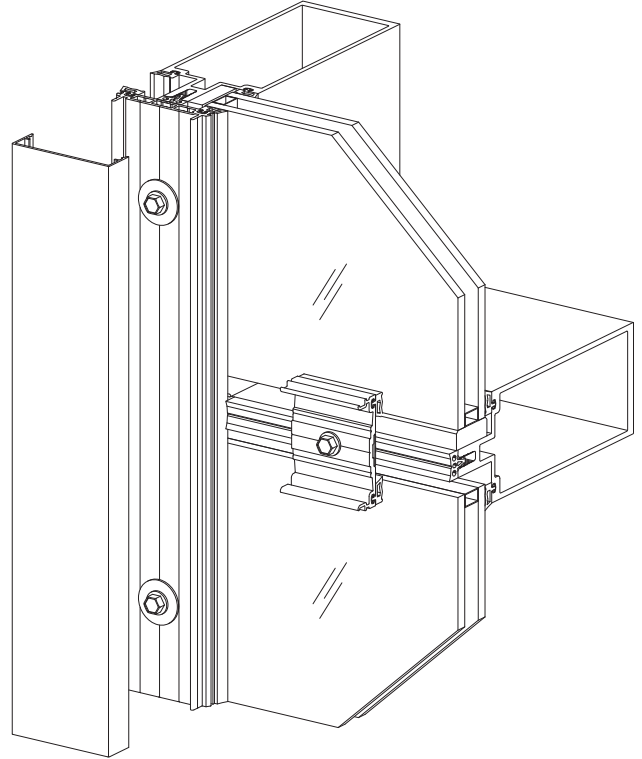

Detail 46

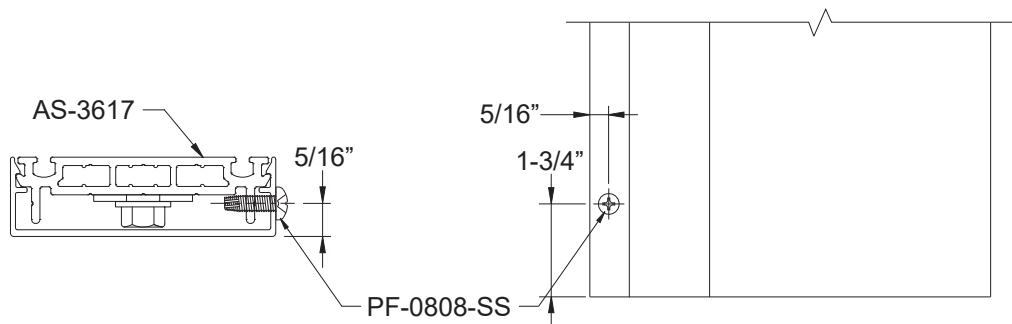

Detail 47

GLAZING

STEP 24A
INSTALL OPTIONAL DEEP FACE COVERS

Installation of a deep vertical cover is similar to that of the standard face cover. Fasteners (PF-0808-SS typical) are required to pin the cover in place. These fasteners are usually located at the horizontals to be concealed by the horizontal face covers. Refer to the approved shop drawings for the number and or spacing of screws required.

-For concealed fastener locations, drill a 0.189" diameter hole into the side of the face cover, 7/16" from the snap interface of the cover. Snap on the deep cover at its intended location. Using the clear hole as a pilot hole, drill a 0.141" diameter tap hole into the leg on the deep pressure plate. Secure the face cover in place with a PF-0808-SS.

-If the face cover requires it to be fastened at an exposed location, drill a 0.189" diameter countersunk hole into the side of the cover. Snap on the deep cover at its intended location. Using the clear hole as a pilot hole, drill a 0.141" diameter tap hole into the leg on the deep pressure plate. Secure the face cover in place with an FC-0808-SS screw.

-Continue to install the horizontal pressure plate and face cover as specified on **Pages 41 & 42**.

See **Detail 48**.

Horizontal face cover applications over 2" in depth should be reviewed by engineering to review possible combined loads.

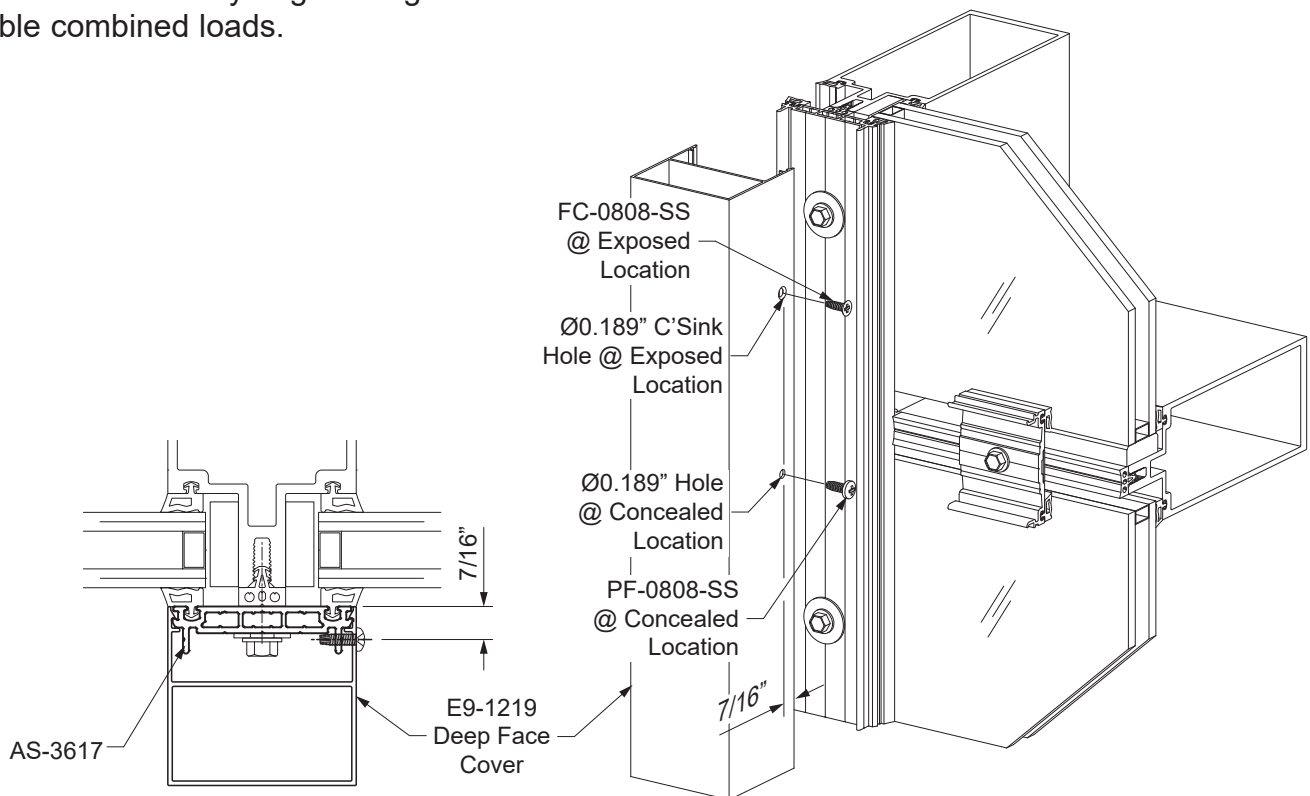

Detail 48

GLAZING

**STEP 25
INSTALL HORIZONTAL PRESSURE PLATES**

- Center and install horizontal pressure plates in opening, leaving a 1/4" gap at the ends.
- Starting at the center of each pressure plate, tighten each retainer screw to 40 to 45 inch-pounds.

See **Detail 49** for pressure plate layout.

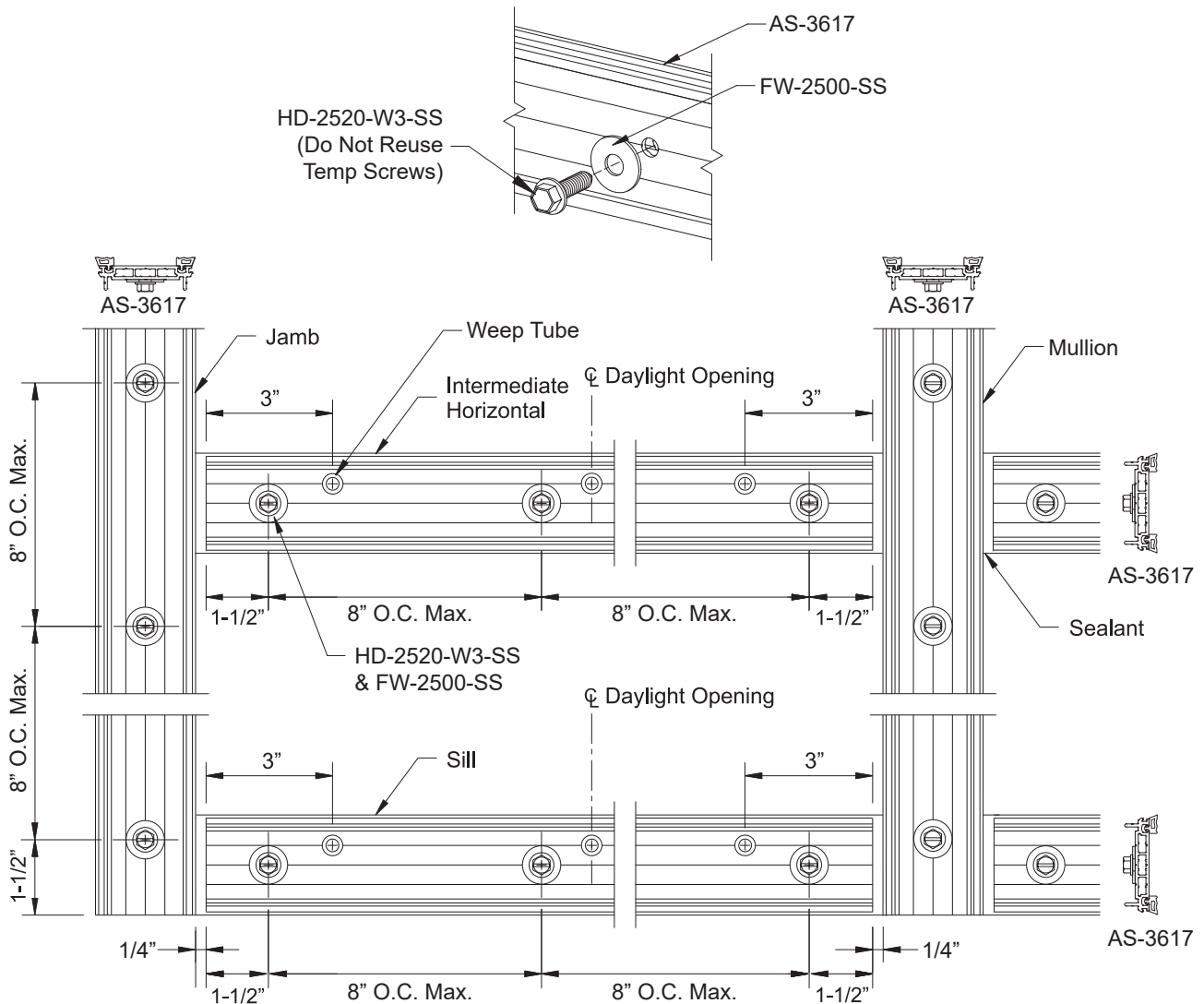

Detail 49

GLAZING

STEP 26
INSTALL EXTERIOR HORIZONTAL FACE COVERS

- Apply and tool sealant between each end of the horizontal pressure plates and the vertical face cover.
- Snap on exterior horizontal face covers.

See **Detail 50**.

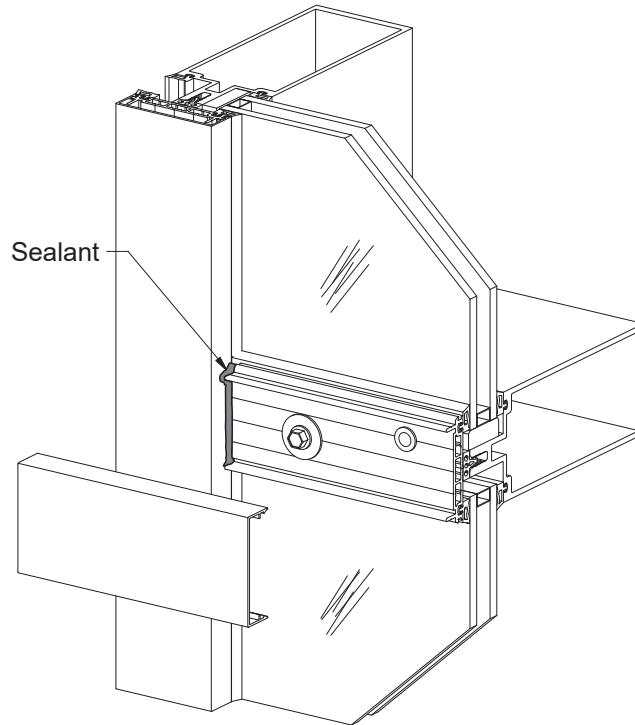

Detail 50

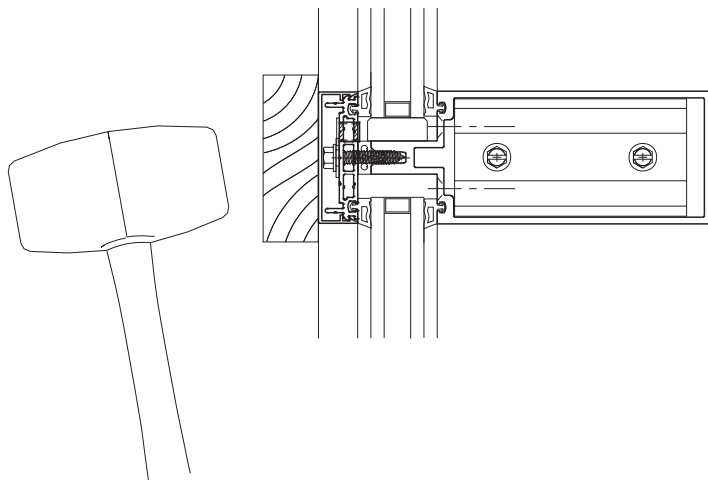

 **YKK AP America Inc.**

101 Marietta Street NW

Suite 2100

Atlanta, Georgia 30303

www.ykkap.com