

YHC 300 OG Outside Glazed Curtain Wall System

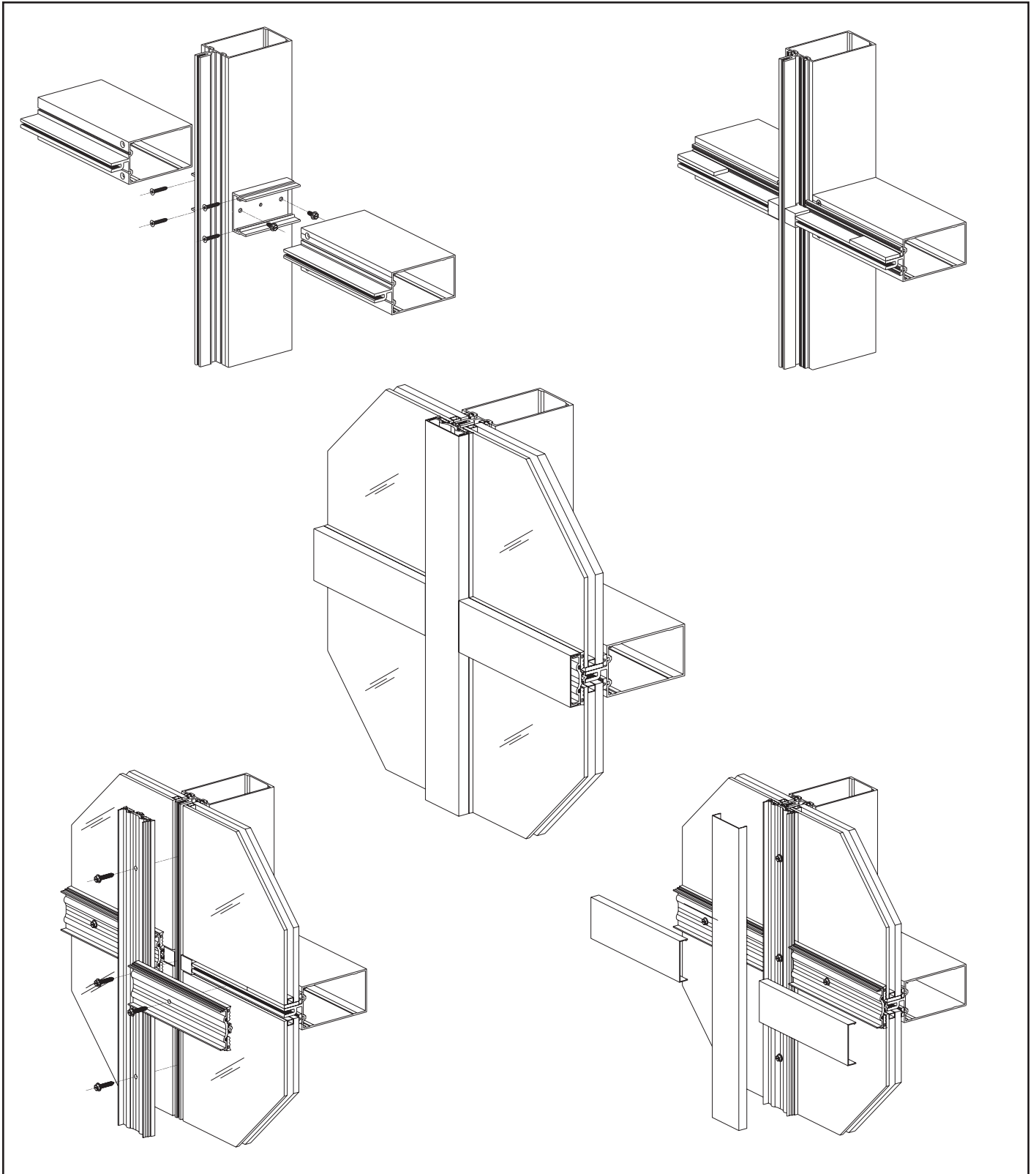

Installation Manual

TABLE OF CONTENTS

Installation Notes	Page ii to iii
PARTS DESCRIPTION	
YHC 300 OG Framing Members (45-55 PSF).....	Pages 1 & 2
YHC 300 OG Accessories (45-55 PSF).....	Pages 3 to 5
YHC 300 OG Framing Members (65-90 PSF).....	Page 6
YHC 300 OG Accessories (65-90 PSF).....	Pages 7 to 9
YHC 300 OG Framing Members (90-130 PSF).....	Page 10
YHC 300 OG Accessories (90-130 PSF).....	Pages 11 to 13
FRAME FABRICATION	
Frame Types/Anchoring Methods	Pages 14 & 15
Fabricate Vertical Mullions	Pages 16 & 18
Fabricate Door Jamb Mullions	Page 19
Using Steel/Alternate Reinforcement	Pages 20 & 21
Shear Blocks for Horizontals.....	Page 22
“J” Anchors at Intermediate Mullions	Page 23
“J” Anchors at Jamb Conditions	Page 24
Fabricate Horizontal Members	Pages 25 to 27
Fabricate Horizontal & Mullion Pressure Plates.....	Pages 28 & 29
Fabricate Mullion Face Covers	Page 30
Fabricate Mullions for Splices	Page 31
FRAME INSTALLATION	
Typical Mullion Splice.....	Page 32
Install Mullion End Caps.....	Page 33
Install Jamb & Mullions	Page 34 & 35
Install Wind Load/Dead Load Anchors.....	Pages 36 & 38
Attach Horizontal Members.....	Pages 39 & 40
90° Corner Assembly	Pages 41 & 42
Install Door Subframes.....	Page 43
Apply Perimeter Sealant	Page 44
GLAZING	
Install 1/4” Glazing Adaptors	Page 45
Install Joint Plugs	Page 46
Install Interior Glazing Spacers/Gaskets	Pages 47 & 48
Install Glass.....	Page 49
Install Pressure Plates	Pages 50 & 51
Install Exterior Face Covers.....	Page 52
Apply Interior Silicone Sealant	Page 53

Installation Notes

1. Do not drop, roll or drag boxes of aluminum framing. Move and stack boxes with proper support to prevent distortion. If fork lifts are used be especially careful about striking the boxes when lifting or moving.
2. Store in a dry, out of the way area. If rain exposure, condensation or any water contact is likely, then all packaging material should be removed. Wet packaging materials will discolor and may stain aluminum finishes and paints.
3. All materials should be checked for quantity and quality upon receipt, YKK AP must be notified immediately of any discrepancies in shipment. Check to make sure that you have the required shims, sealants, supplies, and tools necessary for the installation.
4. Carefully check the openings and surrounding conditions that will receive your material. Remember, if the construction is not per the construction documents, it is your responsibility to notify the general contractor in writing. Any discrepancies must be brought to the general contractor's attention before you proceed with the installation.
5. All work must start from, and be referenced to bench marks, offset lines and/or column centerlines established by the architectural drawings and the general contractor.
6. All vertical mullions must be installed plumb, square, level, and true, and in accordance with approved shop drawings, these installation instructions and AAMA Book 8, installation of aluminum curtain walls.
7. Gather your shop drawings, materials, packing list, and this installation manual. Carefully review parts, location, the sequence it goes therein, when you glaze it and how you seal it. Installation instructions are of a general nature and may not cover every condition you will encounter. The shop drawings and/or installation manuals were prepared specifically for the product.
8. Any material substitutions must be of equal or greater quality.
9. Make certain that material samples have been sent for compatibility testing for all manufacturer's sealants involved. Make certain that sealants have been installed in strict accordance with the manufacturer's recommendations and specifications:
 - A. Specified metal to metal joints use approved silicone sealant. Refer to test report for manufacturer.
 - B. All metal to Large Missile Impact glazing, must use approved silicone sealant. Refer to test report for manufacturer.
 - C. Perimeter caulk joints must use approved silicone sealant. Refer to test report for manufacturer.
 - D. Outside of Florida, YKK AP recommends approved silicone sealant.

Florida product approved installation must always be items A, B, and C.



Installation Notes

10. Consult sealant manufacturer for proper backer rod selection.
11. Remember to isolate, in an approved manner, all aluminum from uncured masonry or other incompatible materials.
12. System-to-structure fasteners are not supplied by YKK AP. Fasteners called out on shop drawings are to indicate minimum sizes for design loading.
13. All substrates which the framing system is anchored to must be structurally sound.
14. Entrances are to be installed plumb, square, level, and true.
15. Please contact the YKK AP DirecTech application engineering department for any project specific condition not covered by these instructions.
16. YKK AP curtain wall framing is typically completed before drywall, flooring and other products which may still be in process. Take the extra time to wrap and protect the work produced.
17. Concrete, mortar, plaster, muriatic acid and other alkaline and acid based construction and cleaning materials may be very harmful to finishes and should be removed with water and mild soap immediately or permanent damage or staining of the finishes will occur. A spot test is recommended before any cleaning agent is used, and abrasive type cleaners must never be used.
18. YKK AP cutting tolerances are plus zero, minus one thirty second unless otherwise noted.
19. Glass and glazing building codes governing the design and use of products vary widely. YKK AP America Inc., does not control the selection of products, product configurations, operating hardware, and function, or glazing materials, and YKK AP assumes no responsibility for these design considerations. It is the responsibility of the design professional, owner, architect, specifier, general contractor, and the installer to make these selections in strict accordance with all applicable codes.
20. Check our website, www.ykkap.com, for the latest installation manual update prior to commencing work.

















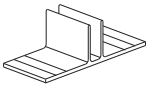

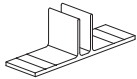

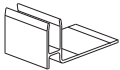

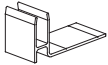
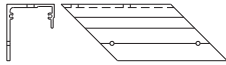
FRAMING MEMBERS (45-55 PSF)

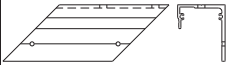
	Head / Sill / Horizontal 3" x 5-1/4" For Monolithic Glazing	E9-3105		Pressure Plate For Monolithic Glazing Punched 9" o.c.	AS-3173
	Horizontal 3" x 3-3/16" For Monolithic Glazing	E9-8168		Pressure Plate For Insulating Glazing Punched 9" o.c.	AS-3172
	Horizontal 3" x 3-3/16" For Monolithic Glazing	E9-8167		Perimeter Pressure Plate For Insulating Glazing Punched 9" o.c.	AS-3178
	Mullion 3" x 5-1/4" For Monolithic Glazing	E9-3107		90° Corner Pressure Plate For Monolithic Glazing Punched 9" o.c.	AS-3177
	Head / Sill / Horizontal 3" x 5-1/4" For Insulating Glazing	E9-3104		90° Corner Pressure Plate For Insulating Glazing Punched 9" o.c.	AS-3175
	Horizontal 3" x 3-3/16" For Insulating Glazing	E9-3112		Face Cover	E9-3161
	Horizontal 3" x 3-3/16" For Insulating Glazing	E9-3113		90° Outside Corner Interior Cover Use with E9-1280	E9-3165
	Mullion 3" x 5-1/4" For Insulating Glazing	E9-3111		90° Outside Corner Interior Cover Base	E9-1280
	Mullion 3" x 3-3/16" For Insulating Glazing	E9-3126		90° Outside Corner Face Cover For Monolithic Glazing	E9-3176
	Horizontal 3" x 3-3/16" For Insulating Glazing	E9-3127		90° Outside Corner Face Cover For Insulating Glazing	E9-3174
	Flush Filler Use With E9-3104 and E9-3105	E9-3162		Pocket Filler For Monolithic Glazing	E9-3109
	Flush Filler Use With E9-3112 and E9-8168	E9-8169		Pocket Filler For Insulating Glazing	E9-3110

FRAMING MEMBERS (45-55 PSF)











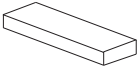

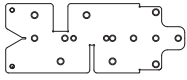









 <p>1-1/2" x 1-1/2" Angle</p>	<p>E9-9303</p>	 <p>1/4" Glazing Adaptor</p>	<p>E9-3141</p>
 <p>Perimeter Pressure Plate For Monolithic Glazing Punched 9" o.c.</p>	<p>AS-3179</p>		

ACCESSORIES (45-55 PSF)

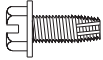



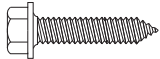

	Shear Block Use With E9-3104 & E9-3105	E1-3001		Face Cover Splice Sleeve Use with E9-3161	E1-3009
	Shear Block Use With E9-3112, E9-3113, E9-8167 & E9-8168	E1-3036		Mullion End Cap For Monolithic Glazing	E1-3011
	“J” Anchor	E1-3002		Mullion End Cap For Insulating Glazing	E1-3010
	Intermediate Vertical Mullion End Anchor Requires E1-3006 Anchor Sleeve	E1-3003		Temporary Pressure Plate For Monolithic Glazing	E1-3026
	Intermediate Vertical Mullion End Anchor For 3” x 3-3/16” Mullion	E1-3046		Temporary Pressure Plate For Insulating Glazing	E1-3025
	Jamb Mullion End Anchor Requires E1-3006 Anchor Sleeve	E1-3004		Shear Block For 90° Corner Mullion	E1-3013
	Jamb Mullion End Anchor For 3” x 3-3/16” Mullio	E1-3047		“J” Anchor (Right Hand) For 90° Corner Mullion	E1-3014
	“T” Anchor Use at Door Jamb	E1-3039		“J” Anchor (Left Hand) For 90° Corner Mullion	E1-3015
	Mullion Splice Sleeve	E1-3005		Shear Clip (Right Hand) For 90° Corner Mullion	E1-3016
	Mullion Anchor Sleeve	E1-3006		Shear Clip (Left Hand) For 90° Corner Mullion	E1-3017
	Mullion Reinforcement Sleeve	E1-3007		Mullion End Anchor For 90° Corner Mullion	E1-3018
	2-1/2” x 2-1/2” x 1/4” Steel Reinforcement Tube For 3” x 3-3/16” mullion	E1-0177		Setting Block For Monolithic Glazing	E2-0623

Note: Exact size of anchors should be determined from loads calculated on each individual curtain wall.

ACCESSORIES (45-55 PSF)

	Setting Block For Insulating Glazing	E2-0611		Interior Glazing Silicone Spacer For Large Missile Gl. that Requires an Interior Struct. Silicone Seal - Above 90PSF	E2-0222
	Side Block	E2-0537		Drill Fixture	H-7213
	Joint Plug For Monolithic Glazing	E2-0358		#8-32 x 1/2" FHTCS Type F Zinc Plated, For Attachment of Face Cover Splice Sleeve	FF-0808
	Joint Plug For Insulating Glazing	E2-0355		#10 x 1" FHSMS Type AB Zinc Plated, For Attachment of Monolithic Glazing Adaptor	FC-1016
	Isolator Tape 3/8" x 1/4" Use with Perimeter Pressure Plate	E2-0386		#12 x 3/4" FHSMS Type AB Zinc Plated, For Attachment of Mullion Splice Sleeve	FC-1212
	Wind Load / Dead Load Anchor Slip Pad	E3-0103		#12 x 1-1/4" FHSMS Type AB Zinc Plated, For Attachment of Horizontal to Shear Block	FC-1220
	Wind Load Anchor* Refer to Shop Drawings for Anchor Dimensions	E1-1204		#14 x 5/8" FHSMS Type AB Zinc Plated, For Attachment of Mullion End Cap	FC-1410
	Dead Load Anchor* Refer to Shop Drawings for Anchor Dimensions	E1-1205		#10 x 5/8" PHSMS Type AB Zinc Plated, For Attachment of E1-3006 Anchor Sleeve	PC-1010
	Jamb Anchor Plate	E1-3536		1/4"-20 x 5/8" HWHTCS Type F , Zinc Plated For Attachment of Shear Block to Vertical	HF-2510 -W1
	Interior/Exterior Glazing Gasket	E2-0379		1/4"-20 x 1" HWHMS Zinc Plated, For Attachment of Pressure Plate to Mullion at Interior Corner	HM-2516 -W3
	Interior/Exterior Glazing Gasket For 1/4" Monolithic and 1" Insulating Glass	E2-0380		1/4"-20 x 1-1/4" HWHMS Stainless Steel, For Attachment of Pressure Plate to Mullion	HD-2520 -W3-SS
	Interior Glazing Silicone Spacer For Large Missile Gl. that Requires an Interior Struct. Silicone Seal - Up to 90PSF	E2-0353		3/8"-16 Nut HHMS Zinc Plated, For Attachment of "J" Anchor	HM-3800

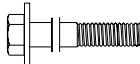
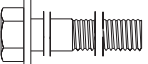













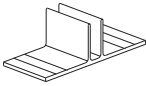
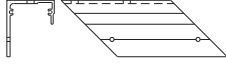
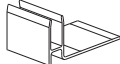
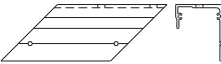

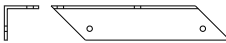

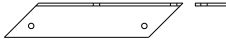

ACCESSORIES (45-55 PSF)

 <p>3/8" Flat Washer Zinc Plated, For Attachment of "J" Anchor</p>	<p>WW-3800</p>	 <p>1/2" Lock Washer Zinc Plated, For Attachment of Mid-Anchors (Wind Load / Dead Load)</p>	<p>WS-5000</p>
 <p>3/8"-16 x 1" HHMS Grade 5 Zinc Plated, For Attachment of "J" Anchor at Jamb</p>	<p>HM-3816</p>	 <p>1/2" Flat Washer Zinc Plated, For Attachment of Mid-Anchors (Wind Load / Dead Load)</p>	<p>WW-5000</p>
 <p>3/8"-16 x 4" HHMS Grade 5 Zinc Plated, For Attachment of "J" Anchor at Intermediate Vertical</p>	<p>HM-3864</p>	 <p>1/2"-13 x 4-1/2" HHMS Grade 5, Zinc Plated, For Attachment of Mid-Anchors (Wind Load / Dead Load)</p>	<p>HM-5072</p>
 <p>3/8" Lock Washer Zinc Plated, For Attachment of "J" Anchor</p>	<p>WS-3800</p>	 <p>1/2"-13 Nut HHMS Zinc Plated, For Attachment of Mid-Anchors (Wind Load / Dead Load)</p>	<p>HM-5000</p>

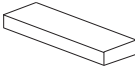
FRAMING MEMBERS (65-90 PSF)

























	Head / Sill / Horizontal 3" x 5-1/4" For Monolithic Glazing	E9-3105		90° Corner Pressure Plate For Monolithic Glazing Punched 9" o.c.	AS-3177
	Horizontal 3" x 5-1/4" For Monolithic Glazing	E9-3106		90° Corner Pressure Plate For Insulating Glazing Punched 9" o.c.	AS-3175
	Mullion 3" x 5-1/4" For Monolithic Glazing	E9-3103		Face Cover	E9-3161
	Head / Sill / Horizontal 3" x 5-1/4" For Insulating Glazing	E9-3104		90° Outside Corner Interior Cover Use with E9-1280	E9-3165
	Intermediate Horizontal 3" x 5-1/4" For Insulating Glazing	E9-3102		90° Outside Corner Interior Cover Base	E9-1280
	Mullion 3" x 5-1/4" For Insulating Glazing	E9-3101		90° Outside Corner Face Cover For Monolithic Glazing	E9-3176
	Flush Filler Use With E9-3104 and E9-3105	E9-3162		90° Outside Corner Face Cover For Insulating Glazing	E9-3174
	Pressure Plate For Monolithic Glazing Punched 9" o.c.	AS-3173		Pocket Filler For Monolithic Glazing	E9-3109
	Pressure Plate For Insulating Glazing Punched 9" o.c.	AS-3172		Pocket Filler For Insulating Glazing	E9-3110
	Perimeter Pressure Plate For Monolithic Glazing Punched 9" o.c.	AS-3179		1-1/2" x 1-1/2" Angle	E9-9303
	Perimeter Pressure Plate For Insulating Glazing Punched 9" o.c.	AS-3178		1/4" Glazing Adaptor	E9-3141

ACCESSORIES (65-90 PSF)





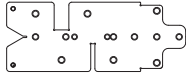

	Shear Block Use With E9-3104 & E9-3105	E9-3001		Temporary Pressure Plate For Insulating Glazing	E1-3025
	"J" Anchor	E1-3002		Shear Block For 90° Corner Mullion	E1-3013
	Intermediate Vertical Mullion End Anchor Requires E1-3006 Anchor Sleeve	E1-3003		"J" Anchor (Right Hand) For 90° Corner Mullion	E1-3014
	Jamb Mullion End Anchor Requires E1-3006 Anchor Sleeve	E1-3004		"J" Anchor (Left Hand) For 90° Corner Mullion	E1-3015
	"T" Anchor Use at Door Jamb	E1-3039		Shear Clip (Right Hand) For 90° Corner Mullion	E1-3016
	Mullion Splice Sleeve	E1-3005		Shear Clip (Left Hand) For 90° Corner Mullion	E1-3017
	Mullion Anchor Sleeve	E1-3006		Mullion End Anchor For 90° Corner Mullion	E1-3018
	Mullion Reinforcement Sleeve	E1-3007		Setting Block For Insulating Glazing	E2-0623
	Face Cover Splice Sleeve	E1-3009		Setting Block For Insulating Glazing	E2-0611
	Mullion End Cap For Monolithic Glazing	E1-3011		Side Block	E2-0537
	Mullion End Cap For Insulating Glazing	E1-3010		Joint Plug For Monolithic Glazing	E2-0358
	Temporary Pressure Plate For Monolithic Glazing	E1-3026		Joint Plug For Insulating Glazing	E2-0355

*Note: Exact size of anchors should be determined from loads calculated on each individual curtain wall.

ACCESSORIES (65-90 PSF)

	Isolator Tape 3/8" x 1/4" Use with Perimeter Pressure Plate	E2-0386		#8-32 x 1/2" FHTCS Type F Zinc Plated, For Attachment of Face Cover Splice Sleeve	FF-0808
	Wind Load / Dead Load Anchor Slip Pad	E3-0103		#10 x 1" FHSMS Type AB Zinc Plated For Attachment of Monolithic Glazing Adaptor	FC-1016
	Wind Load Anchor* Refer to Shop Drawings for Anchor Dimensions	E1-1204		#12 x 3/4" FHSMS Type AB Zinc Plated For Attachment of Mullion Splice Sleeve	FC-1212
	Dead Load Anchor* Refer to Shop Drawings for Anchor Dimensions	E1-1205		#12 x 1-1/4" FHSMS Type AB Zinc Plated For Attachment of Horizontal to Shear Block	FC-1220
	Jamb Anchor Plate	E1-3536		#14 x 5/8" FHSMS Type AB Zinc Plated For Attachment of Mullion End Cap	FC-1410
	Steel Reinforcing 2-1/2" x 4-1/2" x 3/16" x 10'	E1-0175 1000		#10 x 5/8" PHSMS Type AB Zinc Plated For Attachment of E1-3006 Anchor Sleeve	PC-1010
	Steel Reinforcing 2-1/2" x 4-1/2" x 3/16" x 20'	E1-0175 2000		1/4"-20 x 5/8" HWHTCS Type F, Zinc Plated For Attachment of Shear Block to Vertical	HF-2510 -W1
	Interior/Exterior Glazing Gasket	E2-0379		1/4"-20 x 1" HWHTCS Type F Zinc Plated, For Attachment of Shear Block to Vertical with Steel Reinforcing	HF-2516 -W1
	Interior/Exterior Glazing Gasket For 1/4" Monolithic and 1" Insulating Glass	E2-0380		1/4"-20 x 1" HWHMS Zinc Plated, For Attachment of Pressure Plate to Mullion at Interior Corner	HM-2516 -W3
	Interior Glazing Silicone Spacer For Large Missile Gl. that Requires an Interior Struct. Silicone Seal - Up to 90PSF	E2-0353		1/4"-20 x 1-1/4" HWHMS Stainless Steel, For Attachment of Pressure Plate to Mullion	HD-2520 -W3-SS
	Interior Glazing Silicone Spacer For Large Missile Gl. that Requires an Interior Struct. Silicone Seal - Above 90PSF	E2-0222		3/8"-16 Nut HHMS Zinc Plated, For Attachment of "J" Anchor	HM-3800
	Drill Fixture	H-7213		3/8" Flat Washer Zinc Plated, For Attachment of "J" Anchor	WW-3800

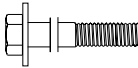
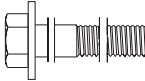
ACCESSORIES (65-90 PSF)

 <p>3/8" Lock Washer Zinc Plated, For Attachment of "J" Anchor</p>	<p>WS-3800</p>	 <p>1/2" Flat Washer Zinc Plated, For Attachment of Mid-Anchors (Wind Load / Dead Load)</p>	<p>WW-5000</p>
 <p>3/8"-16 x 1" HHMS Grade 5 Zinc Plated, For Attachment of "J" Anchor at Jamb</p>	<p>HM-3816</p>	 <p>1/2" Lock Washer Zinc Plated, For Attachment of Mid-Anchors (Wind Load / Dead Load)</p>	<p>WS-5000</p>
 <p>3/8"-16 x 4" HHMS Grade 5 Zinc Plated, For Attachment of "J" Anchor at Intermediate Vertical</p>	<p>HM-3864</p>	 <p>1/2"-13 x 4-1/2" HHMS Grade 5, Zinc Plated, For Attachment of Mid-Anchors (Wind Load / Dead Load)</p>	<p>HM-5072</p>
 <p>1/2"-13 Nut HHMS Zinc Plated, For Attachment of Mid-Anchors (Wind Load / Dead Load)</p>	<p>HM-5000</p>		

FRAMING MEMBERS (90-130 PSF)











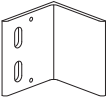

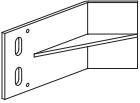



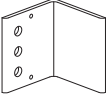

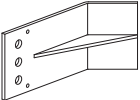



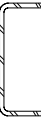

	Head / Sill / Horizontal 3" x 8" For Monolithic Glazing	E9-3189		90° Corner Pressure Plate For Insulating Glazing Punched 9" o.c.	AS-3175
	Horizontal 3" x 8" For Monolithic Glazing	E9-3190		Face Cover	E9-3161
	Mullion 3" x 8" For Monolithic Glazing	E9-3182		90° Outside Corner Interior Cover Use with E9-1280	E9-3160
	Head / Sill / Horizontal 3" x 8" For Insulating Glazing	E9-3187		Interior Cover Use with E9-3185 & E9-3190	E9-3186
	Intermediate Horizontal 3" x 8" For Insulating Glazing	E9-3185		90° Outside Corner Interior Cover Base	E9-1280
	Mullion 3" x 8" For Insulating Glazing	E9-3183		90° Outside Corner Face Cover For Monolithic Glazing	E9-3176
	Flush Filler	E9-3188		90° Outside Corner Face Cover For Insulating Glazing	E9-3174
	Pressure Plate For Monolithic Glazing Punched 9" o.c.	AS-3173		Pocket Filler For Monolithic Glazing	E9-3109
	Pressure Plate For Insulating Glazing Punched 9" o.c.	AS-3172		Pocket Filler For Insulating Glazing	E9-3110
	Perimeter Pressure Plate For Monolithic Glazing Punched 9" o.c.	AS-3179		1-1/2" x 1-1/2" Angle	E9-9303
	Perimeter Pressure Plate For Insulating Glazing Punched 9" o.c.	AS-3178		1/4" Glazing Adaptor	E9-3141
	90° Corner Pressure Plate For Monolithic Glazing Punched 9" o.c.	AS-3177			

ACCESSORIES (90-130 PSF)

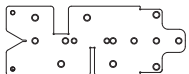

	Shear Block Use With E9-3190 & E9-3185	E1-3032		Temporary Pressure Plate For Insulating Glazing	E1-3025
	Shear Block Use With E9-3189 & E9-3187	E1-3040		Shear Block For 90° Corner Mullion	E1-3027
	Intermediate Vertical Mullion End Anchor Requires E1-3033 Anchor Sleeve	E1-3034		Shear Clip (Right Hand) For 90° Corner Mullion	E1-3028
	Jamb Mullion End Anchor Requires E1-3033 Anchor Sleeve	E1-3035		Shear Clip (Left Hand) For 90° Corner Mullion	E1-3029
	“T” Anchor Use at Door Jamb	E1-3038		Setting Block For Monolithic Glazing	E2-0623
	Mullion Splice Sleeve	E1-3037		Setting Block For Insulating Glazing	E2-0611
	Mullion Anchor Sleeve	E1-3033		Side Block	E2-0537
	Mullion Reinforcement Sleeve	E1-3030		Joint Plug For Monolithic Glazing	E2-0358
	Face Cover Splice Sleeve	E1-3009		Joint Plug For Insulating Glazing	E2-0355
	Mullion End Cap For Monolithic Glazing	E1-3011		Isolator Tape 3/8" x 1/4" Use with Perimeter Pressure Plate	E2-0386
	Mullion End Cap For Insulating Glazing	E1-3010		Wind Load / Dead Load Anchor Slip Pad	E3-0103
	Temporary Pressure Plate For Monolithic Glazing	E1-3026		Wind Load Anchor* Refer to Shop Drawings for Anchor Dimensions	E1-1204

*Note: Exact size of anchors should be determined from loads calculated on each individual curtain wall.

ACCESSORIES (90-130 PSF)

	HD Wind Load Anchor* Refer to Shop Drawings for Anchor Dimensions	E1-1280		#8-32 x 1/2" FHTCS Type F Zinc Plated Steel, For Attachment of Face Cover Splice Sleeve	FF-0808
	HD Corner Wind Load Anchor* Refer to Shop Drawings for Anchor Dimensions	E1-1283		#10 x 1" FHSMS Type AB Zinc Plated Steel, For Attachment of Monolithic Glazing Adaptor	FC-1016
	Dead Load Anchor* Refer to Shop Drawings for Anchor Dimensions	E1-1205		#12 x 3/4" FHSMS Type AB Zinc Plated Steel, For Attachment of Mullion Splice Sleeve	FC-1212
	HD Dead Load Anchor* Refer to Shop Drawings for Anchor Dimensions	E1-1281		#12 x 1-1/4" FHSMS Type AB Zinc Plated Steel, For Attachment of Horizontal to Shear Block	FC-1220
	HD Corner Dead Load Anchor* Refer to Shop Drawings for Anchor Dimensions	E1-1282		#14 x 5/8" FHSMS Type AB Zinc Plated Steel, For Attachment of Mullion End Cap	FC-1410
	Jamb Anchor Plate	E1-3536		#10 x 5/8" PHSMS Type AB Zinc Plated Steel, For Attachment of E1-3006 Anchor Sleeve	PC-1010
	Steel Reinforcing 2-1/2" x 7-1/4" x 3/16" x 10'	E1-3031 1000		1/4"-20 x 5/8" HWHTCS Type F , Zinc Plated Steel For Attachment of Shear Block to Vertical	HF-2510 -W1
	Interior/Exterior Glazing Gasket	E2-0379		1/4"-20 x 1" HWHTCS Type F Zinc Plated Steel, For Attachment of Shear Block to Vertical with Steel Reinforcing	HF-2516 -W1
	Interior/Exterior Glazing Gasket For 1/4" Monolithic and 1" Insulating Glass	E2-0380		1/4"-20 x 1" HWHMS Zinc Plated Steel, For Attachment of Pressure Plate to Mullion at Interior Corner	HM-2516 -W3
	Interior Glazing Silicone Spacer For Large Missile Gl. that Requires an Interior Struct. Silicone Seal - Up to 90PSF	E2-0353		1/4"-20 x 1-1/4" HWHMS Stainless Steel, For Attachment of Pressure Plate to Mullion	HD-2520 -W3-SS
	Interior Glazing Silicone Spacer For Large Missile Gl. that Requires an Interior Struct. Silicone Seal - Above 90PSF	E2-0222		1/2"-13 Nut HHMS Zinc Plated Steel, For Attachment of Mid-Anchors (Wind Load / Dead Load)	HM-5000
	Drill Fixture	H-7213		1/2" Flat Washer Zinc Plated Steel, For Attachment of Mid-Anchors (Wind Load / Dead Load)	WW-5000

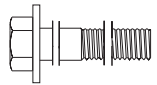
ACCESSORIES (90-130 PSF)

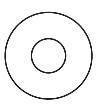
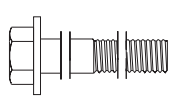
	1/2" Lock Washer Zinc Plated Steel, For Attachment of Mid-Anchors (Wind Load / Dead Load)	WS-5000		1/2"-13 x 4-1/2" HHMS Grade 5, Zinc Plated Steel, For Attachment of Mid-Anchors (Wind Load / Dead Load)	HM-5072
	5/8"-11 Nut HHMS Zinc Plated Steel, For Attachment of Heavy Duty Anchors	HM-5800		5/8" Lock Washer Zinc Plated Steel, For Attachment of Heavy Duty Anchors	WS-5800
	5/8" Flat Washer Zinc Plated Steel, For Attachment of Heavy Duty Anchors	WW-5800		5/8"-11 x 5" HHMS Grade 5 Zinc Plated Steel, For Attachment of Heavy Duty Anchors	HM-5880

FOR FLORIDA PRODUCT APPROVAL APPLICATIONS

*Anchor	Supplier	Part No.	Qty.	Diameter	Edge Distance	Embedment
"F" Anchor	POWERS	WEDGE BOLT	2	1/2"	6"	4"
"F" Anchor	HILTI	KWIK BOLT III 256693	2	3/8"	7-1/2"	2-1/2"
		SUPER ROD ADHESIVE 68658		1/2"	6-3/4"	4-1/4"
"T" Anchor	POWERS	WEDGE BOLT	2	1/2"	6"	4"
"T" Anchor	POWERS	WEDGE BOLT	2	1/2"	6"	4"
"J" Anchor	POWERS	WEDGE BOLT	2	1/2"	6"	4"
"J" Anchor	HILTI	KWIK BOLT III 256693	2	3/8"	7-1/2"	2-1/2"
		SUPER ROD ADHESIVE 68658		1/2"	6-3/4"	4-1/4"
"J" Anchor	POWERS	WEDGE BOLT	2	1/2"	6"	4"
"J" Anchor	POWERS	WEDGE BOLT	2	1/2"	6"	4"
"J" Anchor	POWERS	WEDGE BOLT	2	1/2"	6"	4"

***Note:** Anchor fasteners are not furnished by YKK AP.
All anchors are assumed in 3,000 PSI concrete.
Anchor bolt size and location will vary according to engineering calculations.

FRAME FABRICATION

FRAME TYPES / ANCHORING METHODS:

Note: The following is a guideline for types of frames. Refer to the shop drawings or consult YKK AP for exact layout of frames. These installation instructions are to be used in conjunction with approved shop drawings. Consult shop drawings for anchorage of mullions to structure.

Larger units require being stick assembled in place.

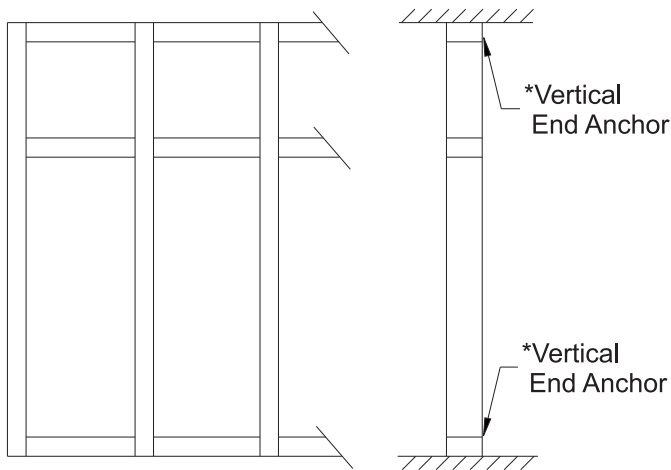

SINGLE SPAN

Smaller units may be assembled on the ground and lifted in place.

Note: If YKK AP does not prepare the shop drawings for the project, a qualified engineer must approve all anchors and mullions for wind load and dead load.

*Vertical end attachment will be “J”, “F”, and/or “T” mullion end anchors. Refer to shop drawings or consult YKK AP.

Note: Structure must be capable of resisting all loads imposed by anchor reactions.

Fabrication of YHC 300 OG Curtain Wall varies depending on which anchors are required for a given project.

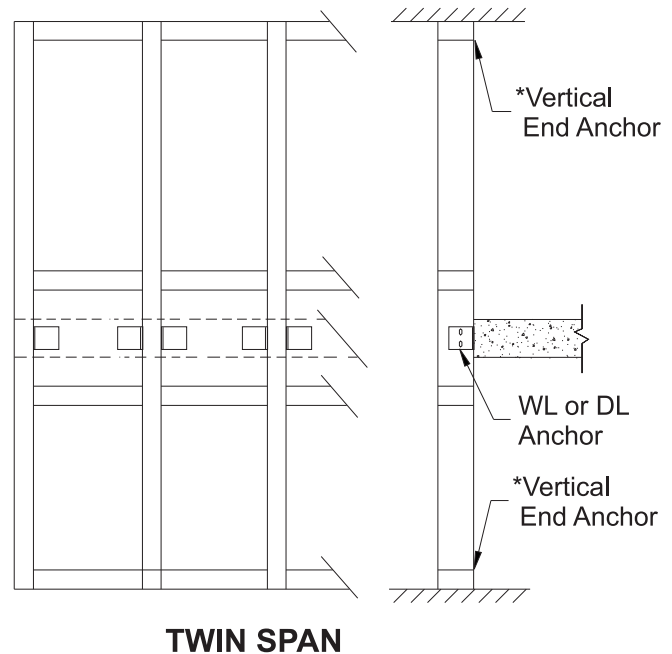

TWIN SPAN

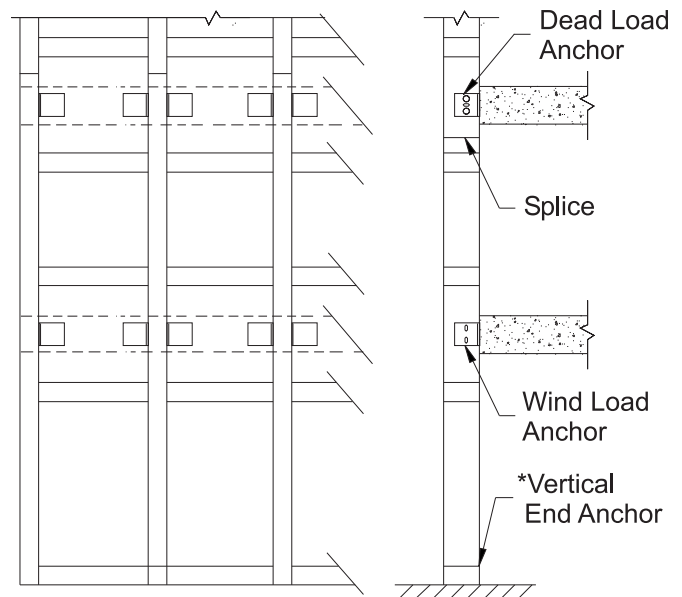

MULTI-SPAN

FRAME FABRICATION

Using mullion end anchors:

YHC 300 OG has three possible end anchoring conditions: "J", "T", and "F".

- "J" anchors are used with jambs and intermediate mullions at the sill only.
- "T" anchors are used with intermediate mullions at the head and sill.
- "F" anchors are used with jamb mullions at the head and sill.
- "Door Jamb" anchors are used with mullions at a door jamb and are specified by the approved shop drawings or P.E. calcs.
- Anchor usage depends on end reaction, stress, and attachment.

Mullions should be pre-assembled with shear blocks, end anchors, and steel or aluminum reinforcing if necessary.

Framing members:

- Open back members are used for all head and sill applications.
- Closed horizontal members are used at all intermediate locations with the exception of end bays.
- Open back members are used for intermediate horizontals at end bays, to slide over the shear blocks.

Note: When using stick built construction, check for plumb, level, and overall frame width every fifth mullion. This helps to avoid the build up of cumulative tolerance errors. Also check that all anchors are secure and firmly attached to the building structure.

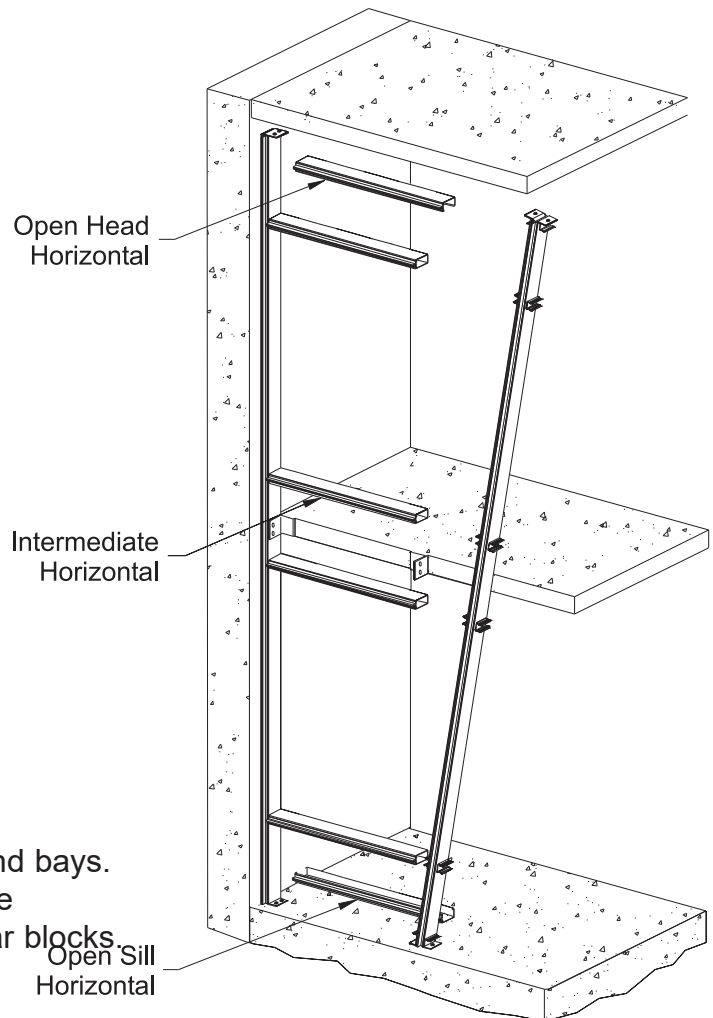

FRAME FABRICATION

FABRICATE MULLIONS (45-90 PSF)

Step 1

-Cut all mullions to dimensions as shown on shop drawings.
 Allow 1/2" for splices and 1/2" caulk joint around the perimeter of the frame.

Step 2

Mullion hole locations for attachment of shear blocks, or "J" anchor are shown below:

-Locate and drill holes in mullions at the locations shown in **Detail 1**.

Note: Mullion hole locations and diameters vary depending on shear block or "J" Anchor usage.
 For most applications, "J" Anchors are used at the sill only.

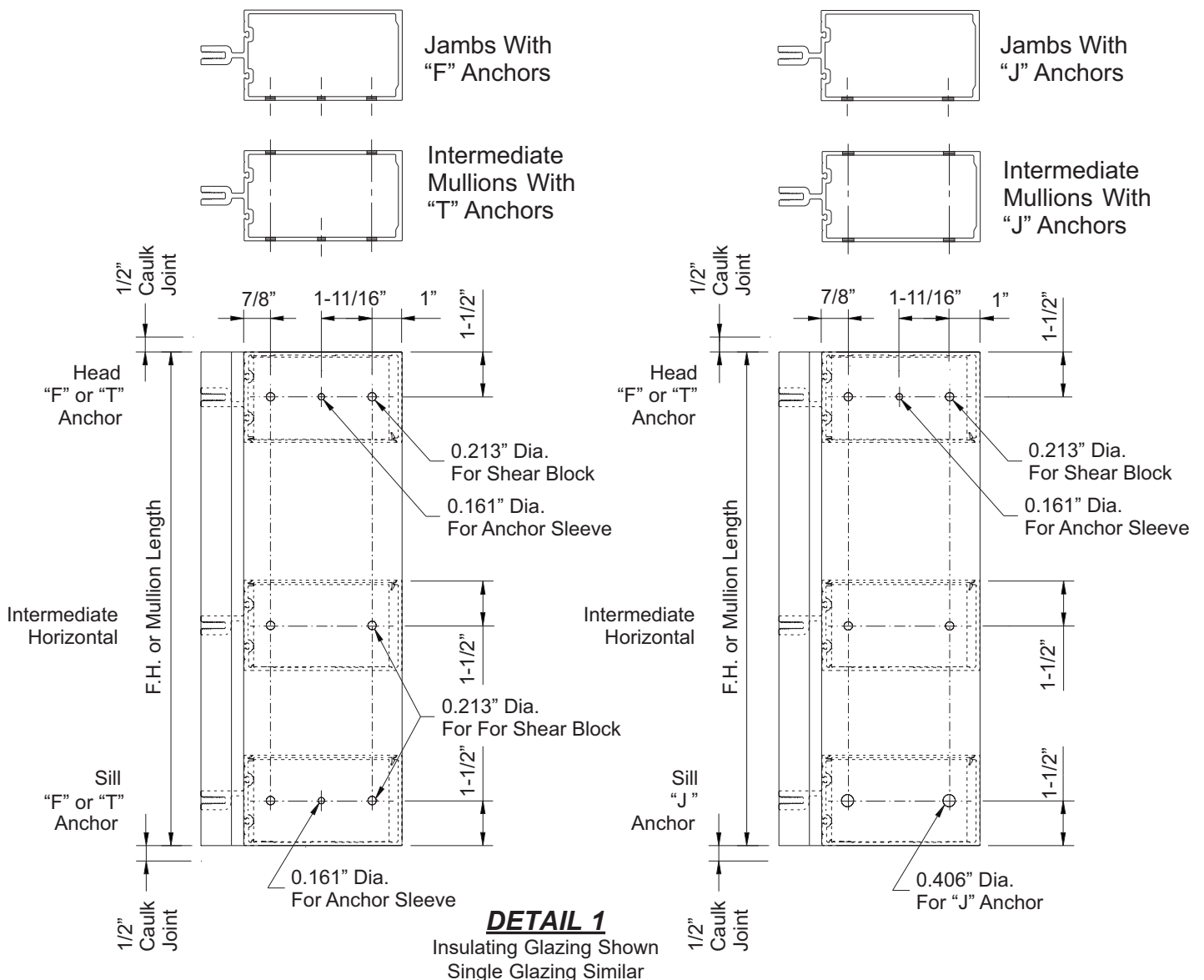

FRAME FABRICATION

FABRICATE SHALLOW MULLIONS (45-55 PSF ONLY)

-Fabrication for 3" x 3-3/16" mullions is similar to that shown on the previous page except J-anchors, anchor sleeves, and splices are not used.

See **Detail 1A**.

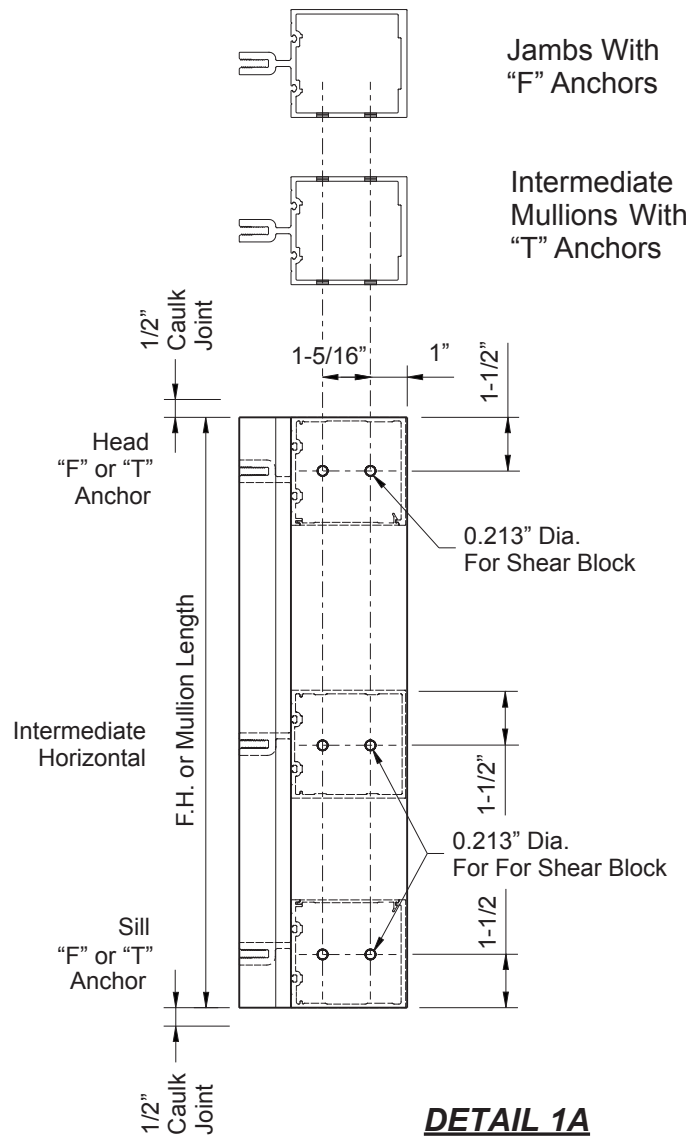

DETAIL 1A

Insulating Glazing Shown
Single Glazing Similar

FRAME FABRICATION

FABRICATE MULLIONS (90-130 PSF)

Step 1

-Cut all mullions to dimensions as shown on shop drawings.

Allow 1/2" for splices and 1/2" minimum caulk joint around the perimeter of the frame.

See **Detail 2**.

Note: Mullion hole locations and diameters vary depending on shear block or "J" Anchor usage.
"J" Anchors are used at the sill only.

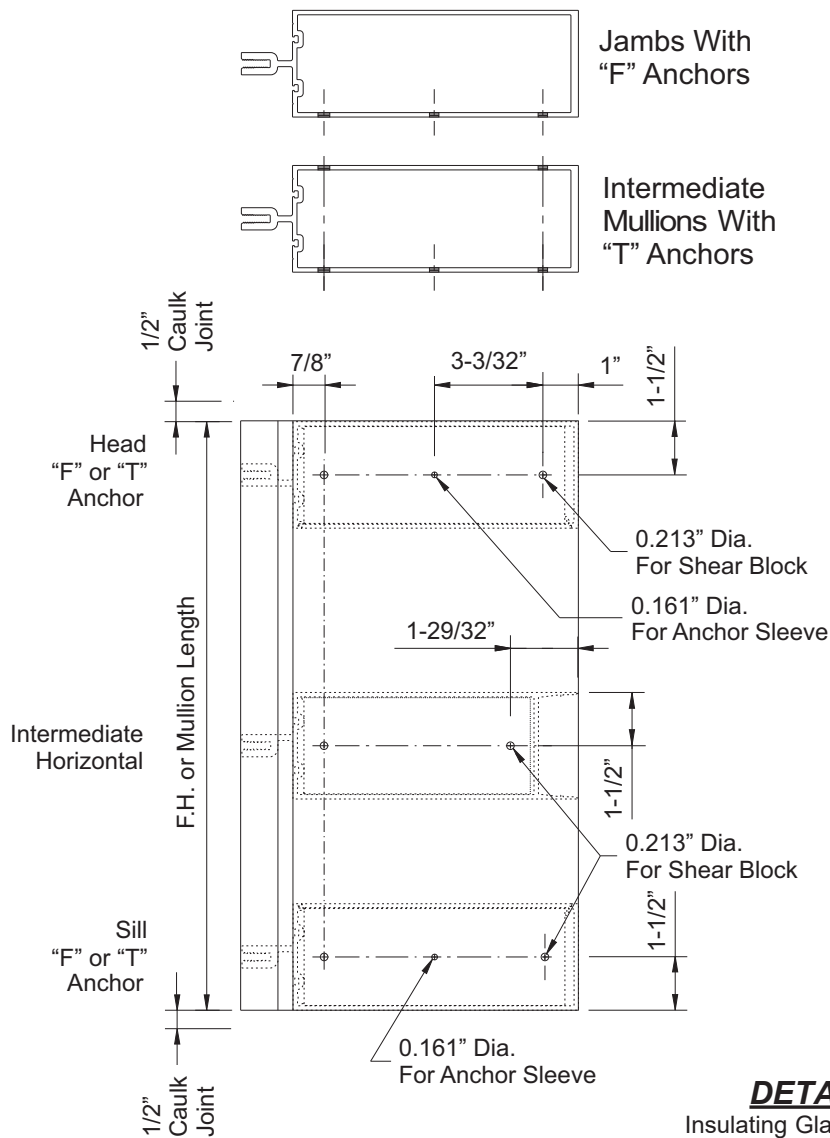

DETAIL 2

Insulating Glazing Shown
Single Glazing Similar

FRAME FABRICATION

FABRICATE DOOR JAMB MULLIONS

Step 1

-Cut all mullions to dimensions as shown on shop drawings.
 Allow 1/2" for splices and 1/2" caulk joint at the top of the frame.

Step 2

Mullion hole locations for attachment of shear blocks are shown below:
 -Locate and drill holes in mullions at the locations shown in **Detail 3**.

Note: Mullion hole locations and diameters vary depending on shear block usage.
 "J" Anchors are not used at door jambs.

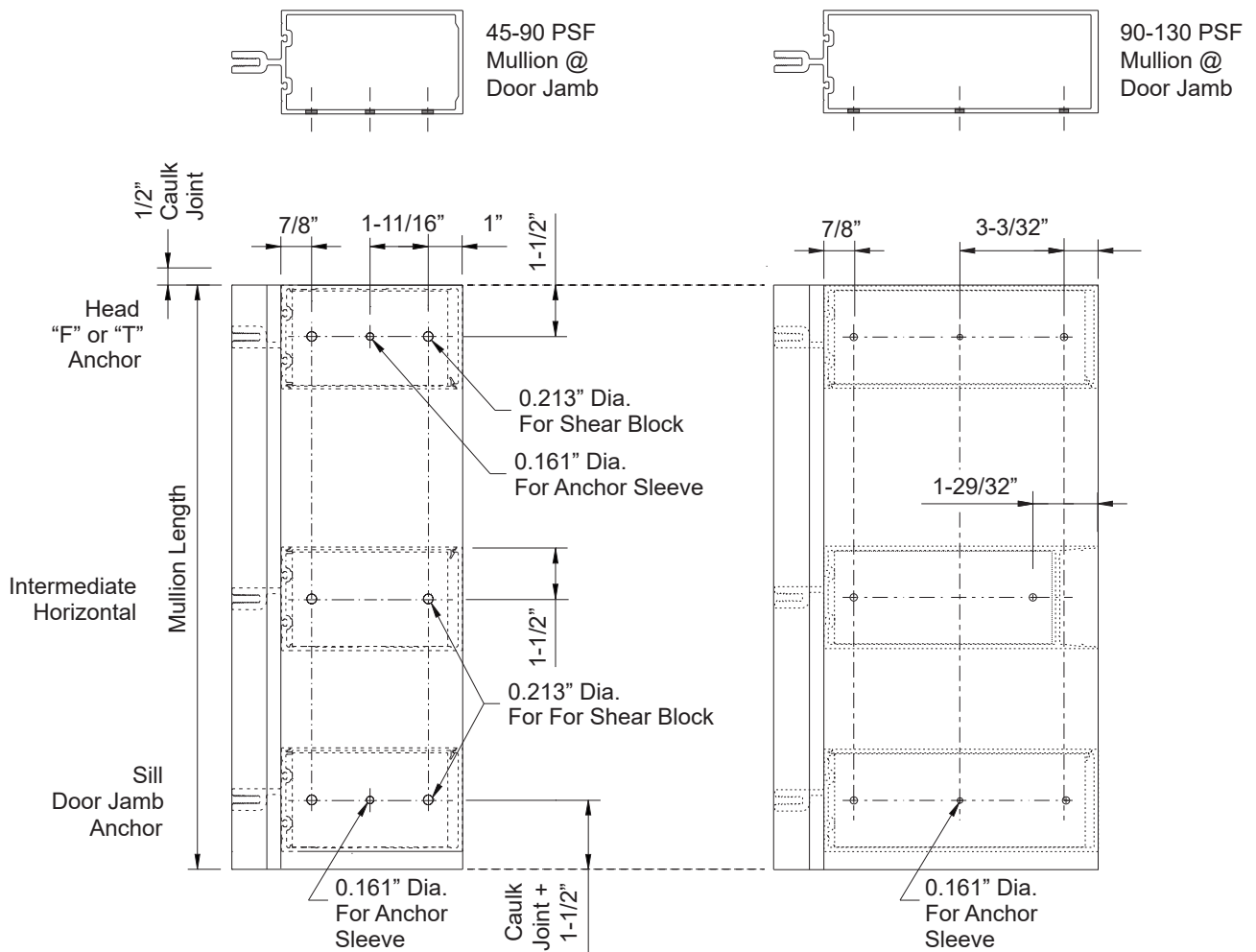

DETAIL 3

Insulating Glazing Shown
 Single Glazing Similar

FRAME FABRICATION

**STEP 3
USING ALTERNATE REINFORCEMENT, STEEL CHANNEL**

- Reference the shop drawings for the location of horizontals. The steel channel is always fastened through the shear clip.
- Drill a 0.281" diameter hole in the vertical mullion being careful to not drill a hole in steel channel.
- Reinforcing must allow clearance for anchor sleeve; locate reinforcing a minimum of 3-1/4" from the end of the mullion.

See **Detail 4**.

- Drill a 0.213" diameter hole in steel channel through the same hole locations using a #3 diameter drill bit.
- Attach shear block using two HF-2516- W1 fasteners per block. See **Detail 4**.

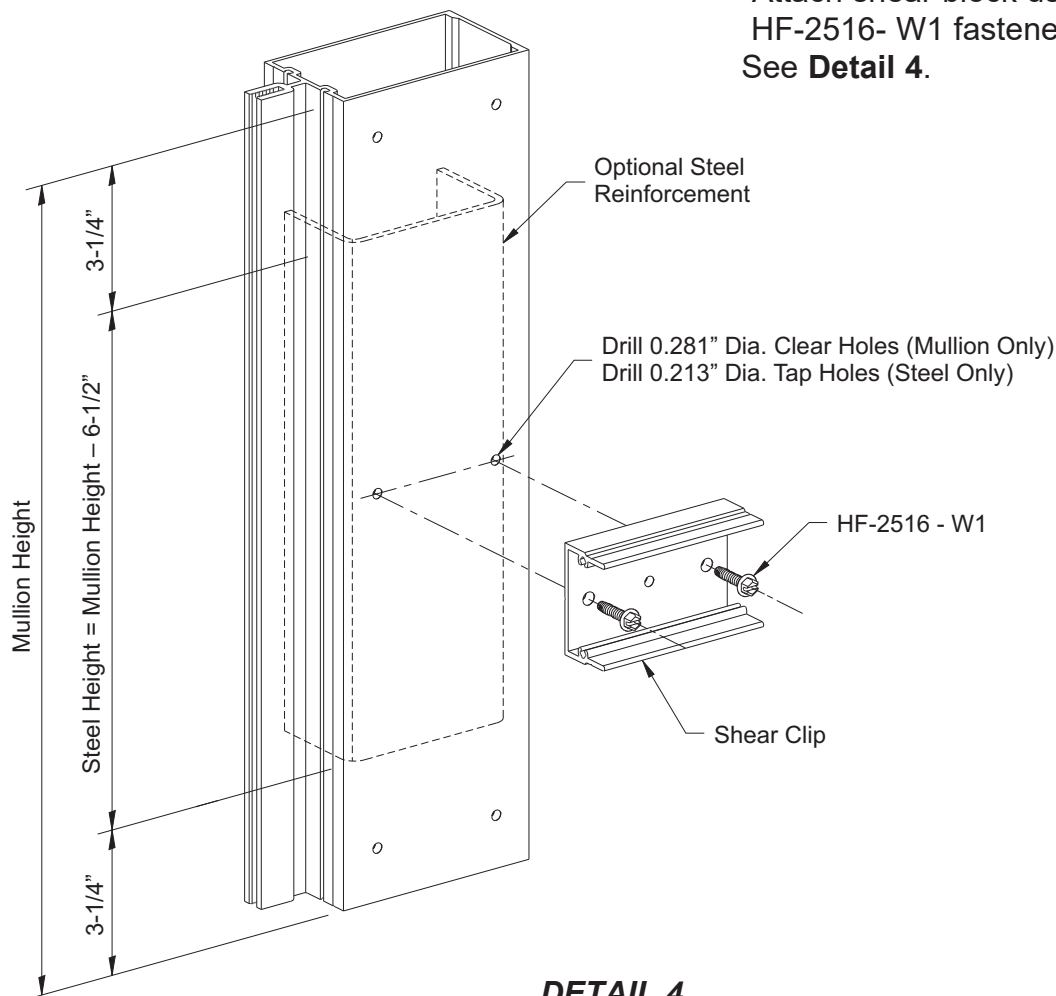

DETAIL 4
Insulating Glazing Shown
Single Glazing Similar

FRAME FABRICATION

STEP 3 (Continued)
USING ALTERNATE REINFORCEMENT, REINFORCEMENT SLEEVE

- If the engineering calculations require the vertical mullions to be reinforced with additional aluminum, a reinforcement sleeve may be used.
- Checking stress levels at point load areas will require different anchors or possibly steel reinforcing.
- A qualified professional engineer should do these calculations.

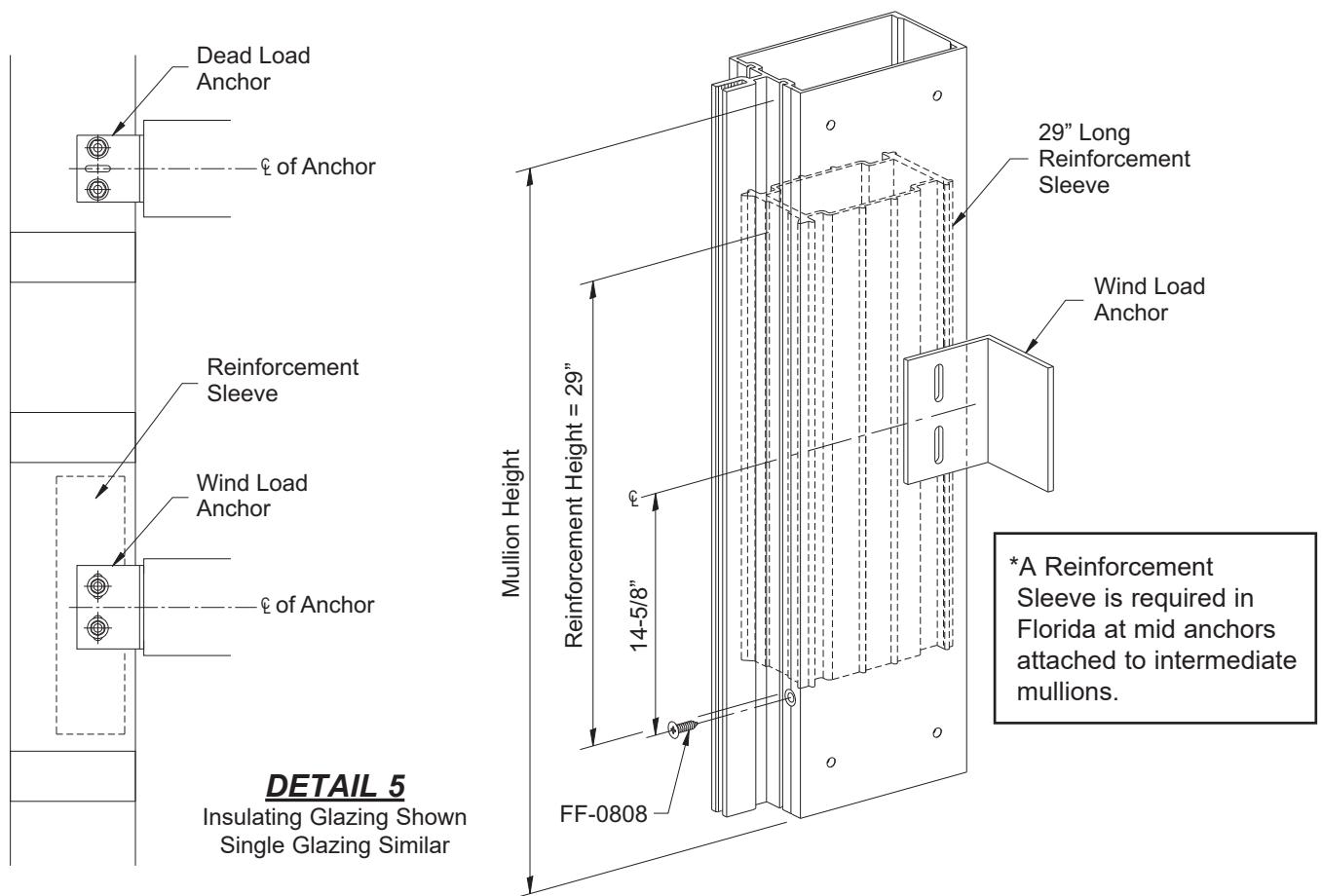

*A Reinforcement Sleeve is required in Florida at mid anchors attached to intermediate mullions.

DETAIL 5
 Insulating Glazing Shown
 Single Glazing Similar

- When locating reinforcement sleeve at wind load or dead load anchors see **Detail 5**.
 - Reference the shop drawings for the exact location of the centerline of the wind load / dead load anchors.
 - From the centerline measure down 14-5/8" along the "V"-groove of the vertical and locate hole for FF-0808 fastener as a stop for reinforcement sleeve.
 - Drill a 0.141" diameter hole into the V-Groove of vertical.
 - Countersink for #8 flat head screw and install FF-0808 fastener.
- See **Detail 5**.

FRAME FABRICATION

Mullions with "F" or "T" Anchors at Head & Sill

STEP 4 SHEAR BLOCKS FOR HORIZONTALS

Shear blocks are used to attach horizontal members to the mullions.

-Fasten shear blocks to the mullion with two HF-2510-W1 fasteners per clip.

The anchor sleeve centers the "F" and "T" mullion end anchors and must be installed when using "T" and "F" anchors. Anchor sleeves are not required when using a "J" anchor.

-Attach the anchor sleeve to the mullion and shear blocks with one PC-1010 fastener.

Anchor sleeves are attached only on one side of the mullion.

See **Detail 6**.

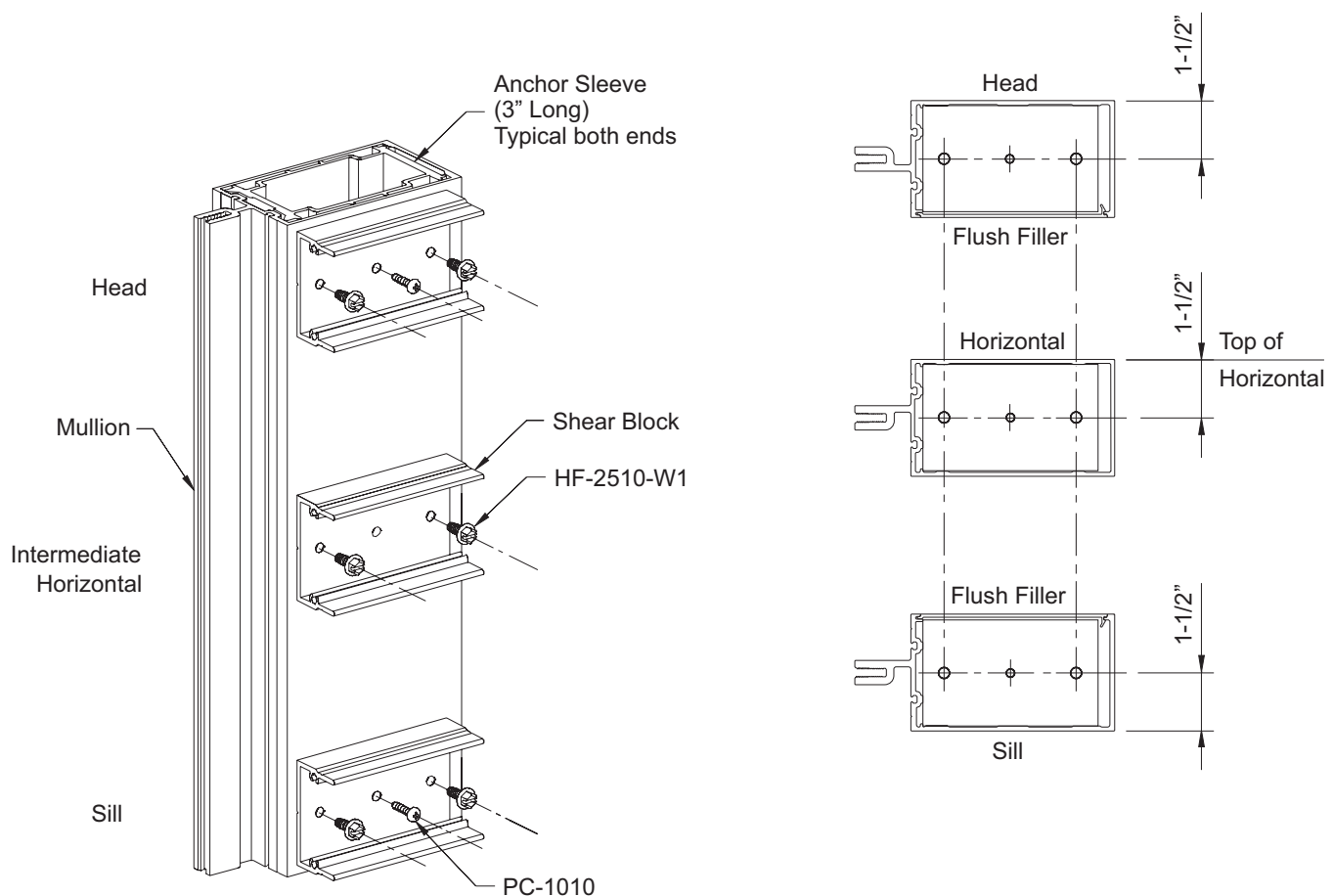

DETAIL 6

Insulating Glazing Shown
Single Glazing Similar

FRAME FABRICATION

Mullions with "T" Anchor at Head & "J" Anchor at Sill

STEP 5

"J" ANCHORS AT INTERMEDIATE MULLIONS

The "J" anchor is installed without the anchor sleeve and is designed to be attached to intermediate mullions and jambs using two through bolts as shown below.

- Align the "J" anchors and insert the HM-3864 bolts through both anchors and the mullion.
- Install 3/8" flat washers and 3/8" lock washers between the anchor and HM-3800 hex nuts.

See **Detail 7**.

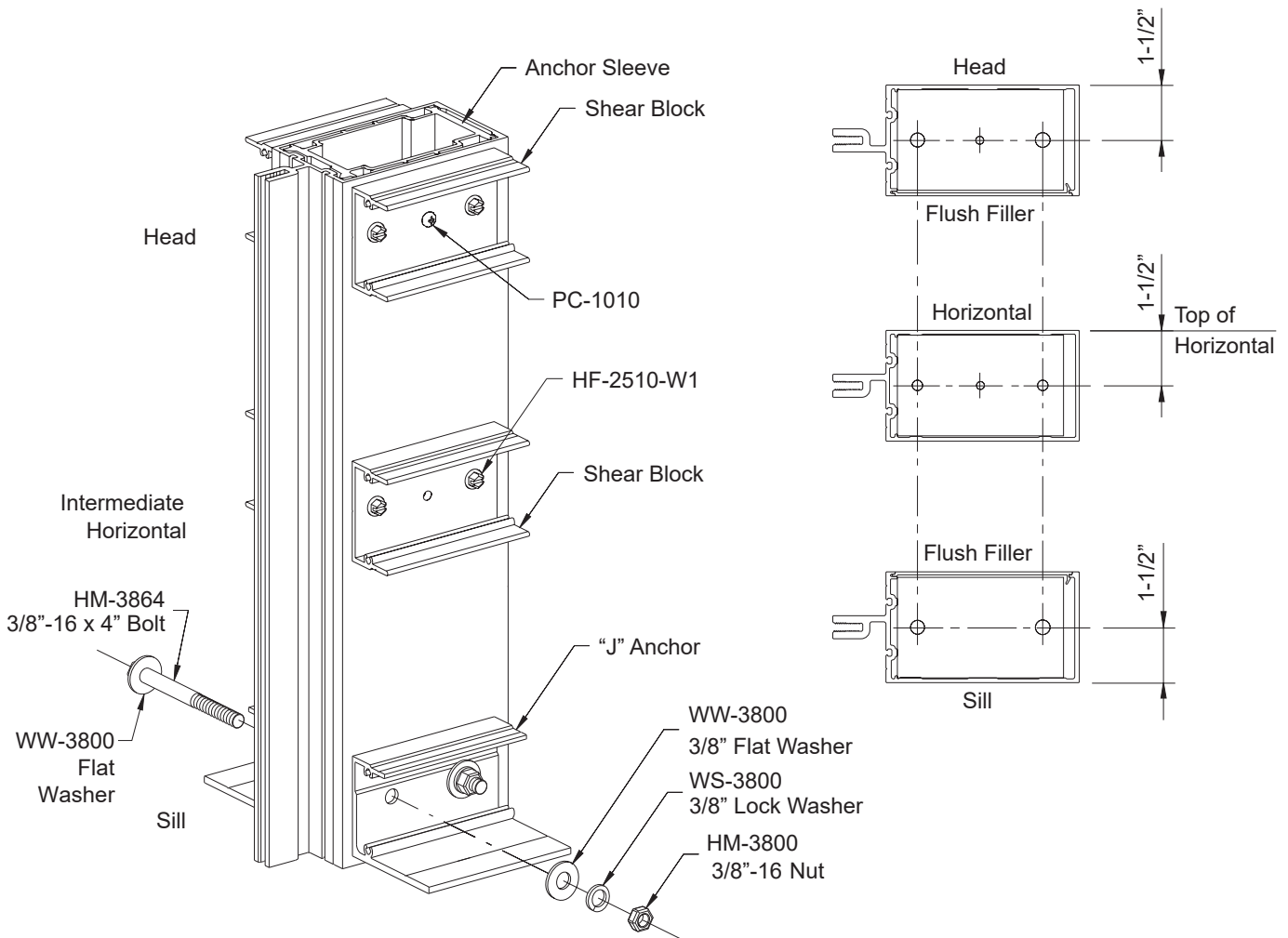

DETAIL 7

Insulating Glazing Shown
Single Glazing Similar

FRAME FABRICATION

Mullions with "T" Anchor at Head & "J" Anchor at Sill

STEP 5 (Continued)

"J" ANCHORS AT JAMB MULLIONS

A "J" anchor is installed without anchor sleeve, and is designed to be attached to jamb mullions using two 3/8" x 1" bolts as shown below.

Note: "J" anchors are not to be used with 90-130 PSF mullions.

-Align the "J" anchor with the mullion and insert the HM-3816 bolts through the inside of the mullion and out the "J" anchor.

-Install 3/8" flat washers and 3/8" lock washers between the anchor and HM-3800 hex nuts.

See **Detail 8**.

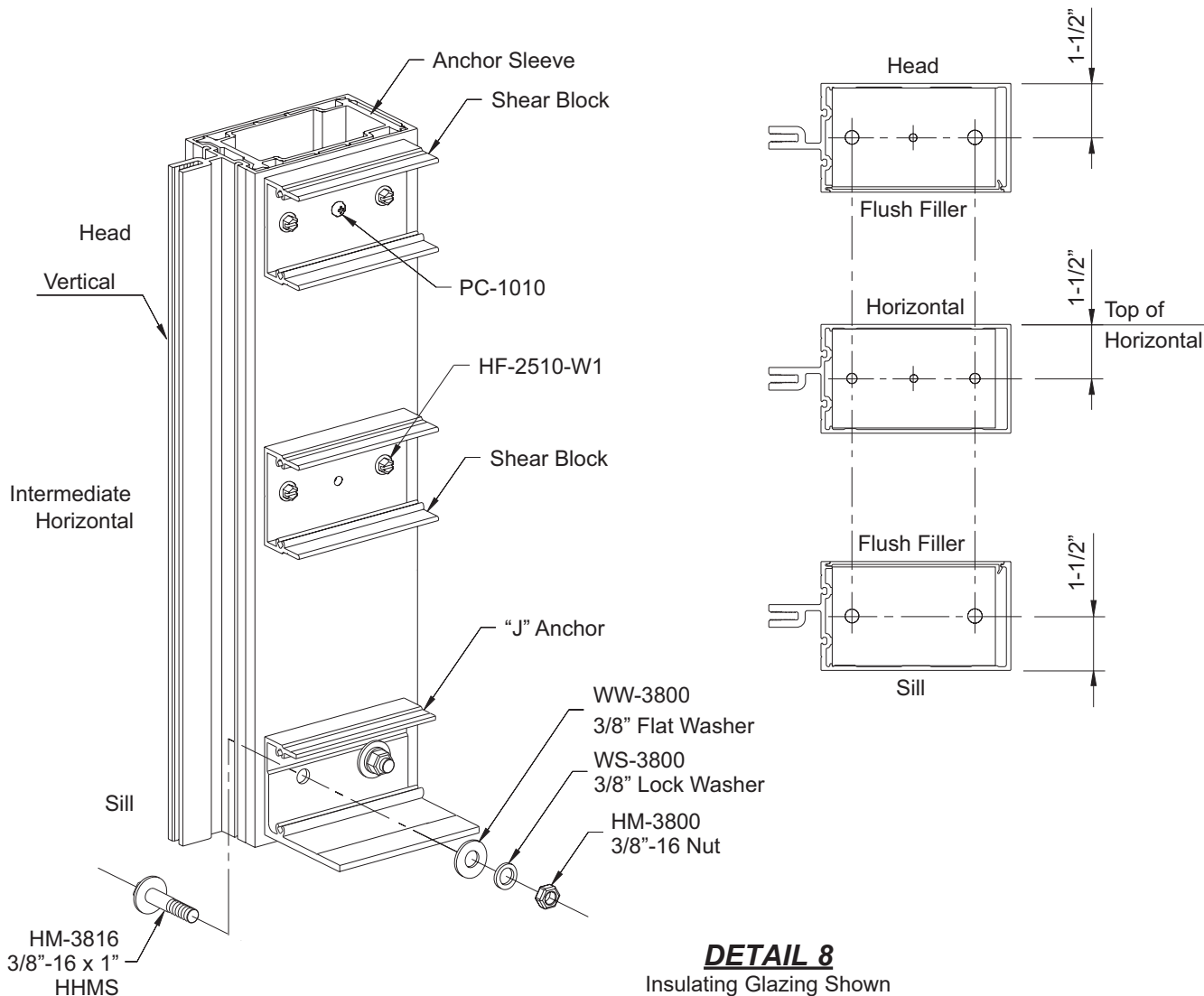

DETAIL 8
Insulating Glazing Shown
Single Glazing Similar

FRAME FABRICATION

**STEP 6
FABRICATE HORIZONTAL MEMBERS**

- Cut all head, horizontal, sill members, and flush fillers to the daylight opening.
- Drill two 0.236" (#B) dia. holes along the "V"-Grooves above and below the mullion tongue on both ends of the mullion to attach members to the shear bocks.

Note: Closed back horizontals are not to be used at head or sill conditions.

See **Details 9 & 10.**

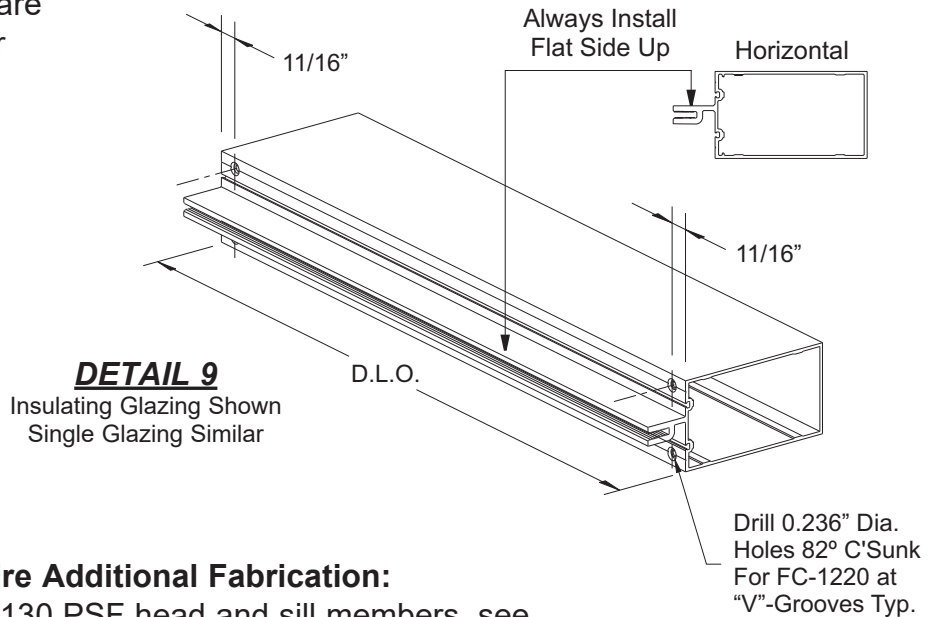

Head and Sill Members Require Additional Fabrication:

Note: For fabrication of 90-130 PSF head and sill members, see **DETAIL 12** on **Page 26.**

- Drill appropriate size clearance holes at each end of the mullion as shown in **Detail 10**, or according to shop drawings or engineering calculations to clear anchor bolts and nuts.

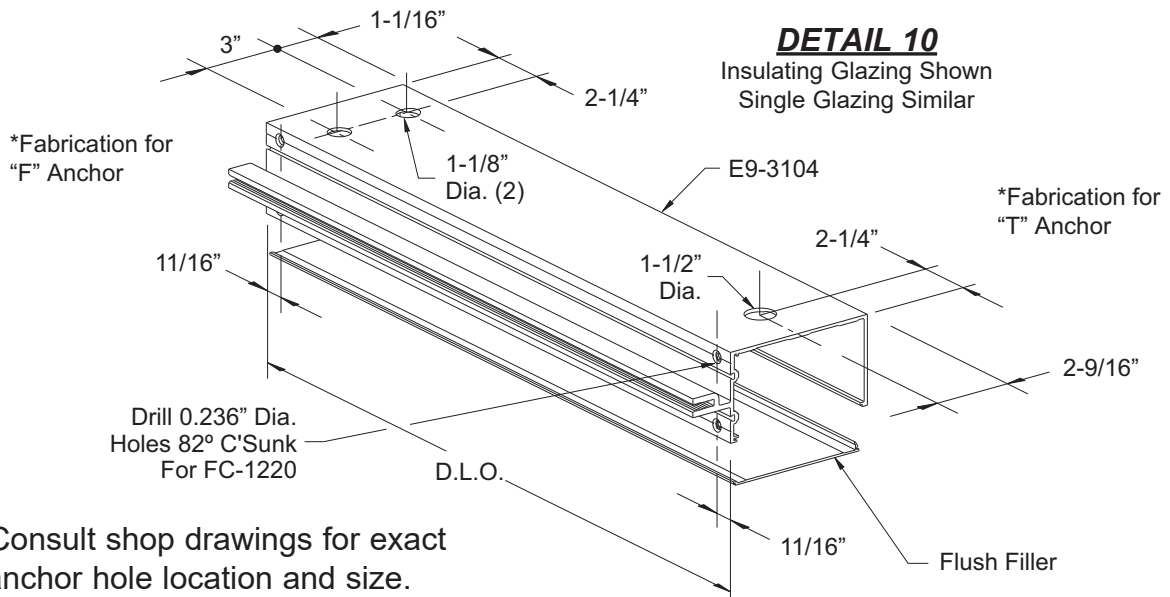

Note: *Consult shop drawings for exact anchor hole location and size.

FRAME FABRICATION

**STEP 6
FABRICATE HORIZONTAL MEMBERS (Continued)
For 90-130 PSF Mullions**

Head and Sill Members Require Additional Fabrication:

-Drill appropriate size clearance holes at each end of the mullion as shown in **Detail 11**, or according to shop drawings or engineering calculations to clear anchor bolts and nuts.

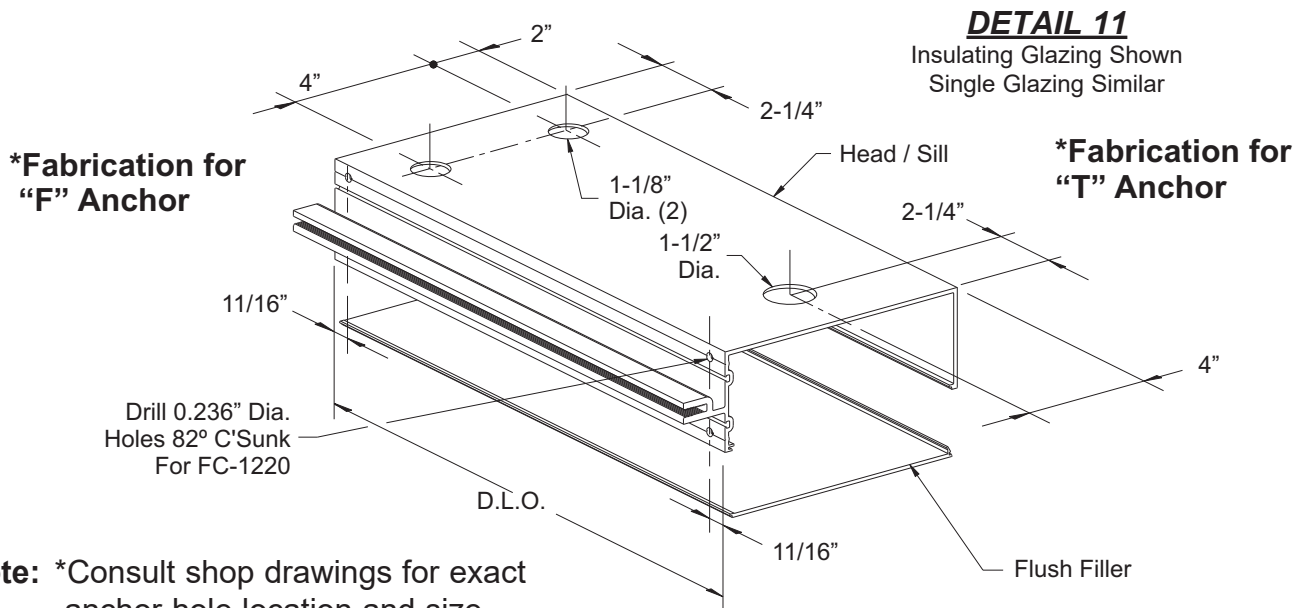

Note: *Consult shop drawings for exact anchor hole location and size.

**FABRICATE HORIZONTAL END BAYS
For 90-130 PSF Mullions**

-When using tubular horizontals at end bays, horizontals must slide in from the exterior.
-In order to clear the shear blocks on the verticals, notch the rear face of the horizontal at both ends as shown below.

See **Detail 12**.

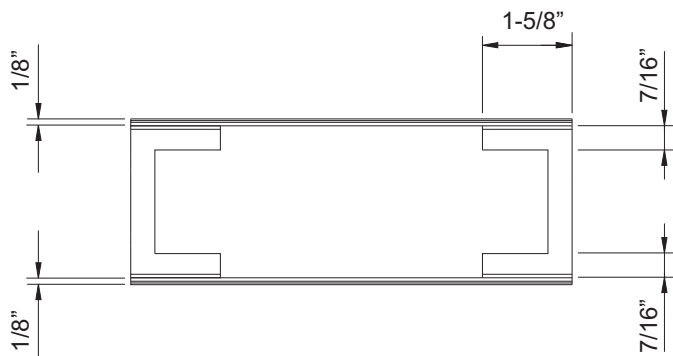

DETAIL 12
Insulating Glazing Shown
Single Glazing Similar

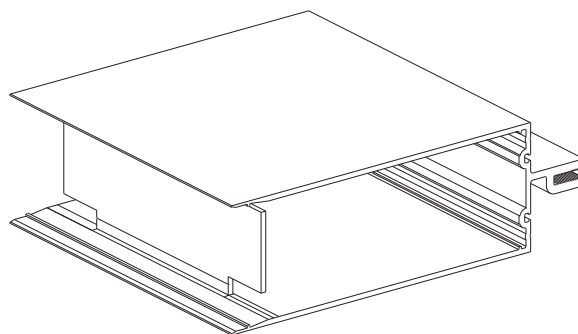

FRAME FABRICATION

STEP 6 (Continued)
FABRICATE HORIZONTAL MEMBERS

-When using "J" anchors, drill appropriate size clearance holes at each end of the sill member as shown in **Detail 13**, or according to shop drawings or engineering calculations to clear anchor bolts.

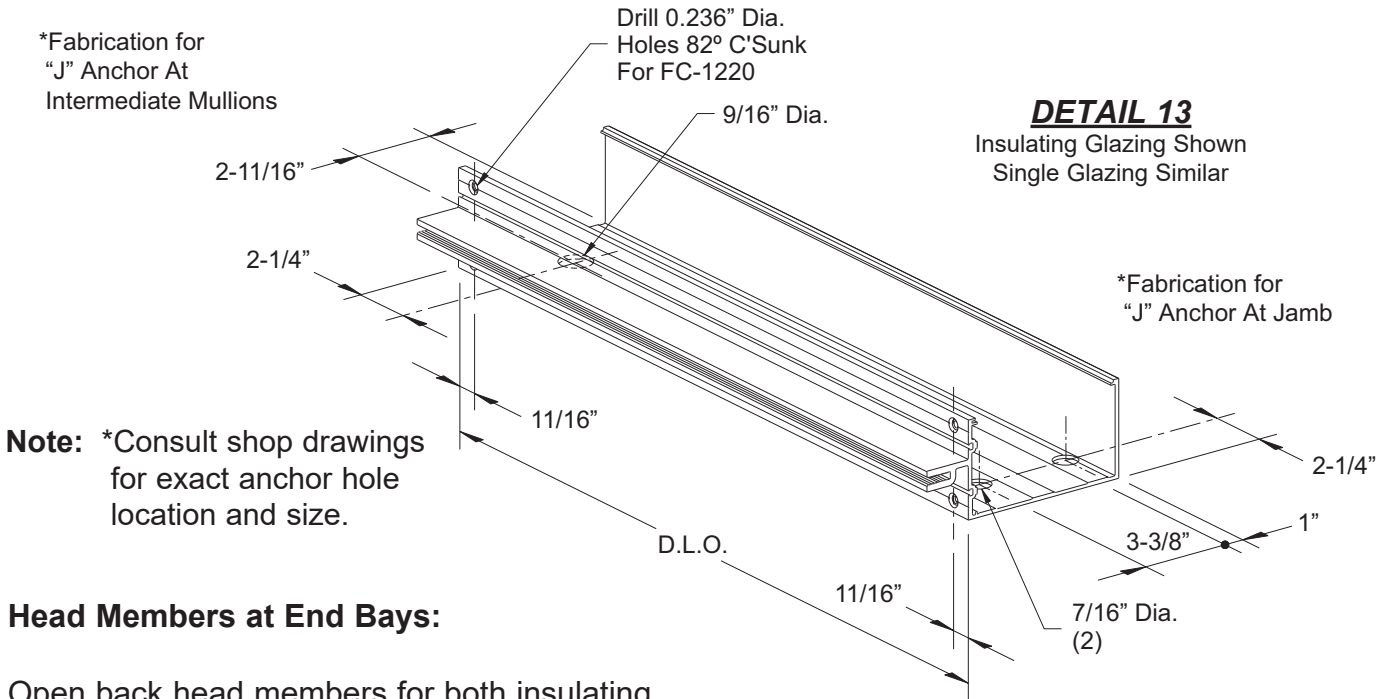

Head Members at End Bays:

Open back head members for both insulating glazing and single glazing are installed with the open side facing the structure at end bays to clear the anchor bolts:

- Cut the flush filler to Daylight Opening minus(-) 7".
- Snap in the flush filler centered across the width of the mullion.

See **Detail 14**.

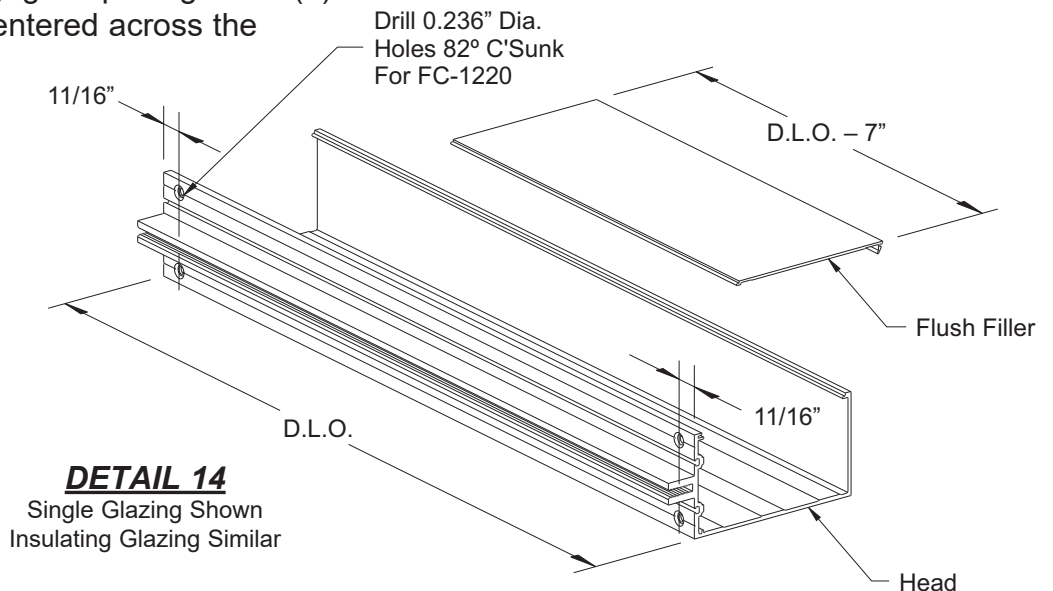

FRAME FABRICATION

STEP 7

FABRICATE HEAD, SILL, AND HORIZONTAL PRESSURE PLATES

- Cut horizontal pressure plates to the daylight opening between verticals minus(-) 1/4".
- Pressure plate stock lengths have 0.281" dia. holes factory punched every 9".
After cutting, drill additional holes if required to ensure that end holes are 1-1/2" from each end.
- Drill two 0.313" (5/16") diameter weep holes 3" from each end and one at the centerline of the pressure plate.

See **Detail 15a for Horizontal Pressure Plate Fabrication.**

See **Details 15b on Page 29 for Head and Sill Perimeter Pressure Plate Fabrication.**

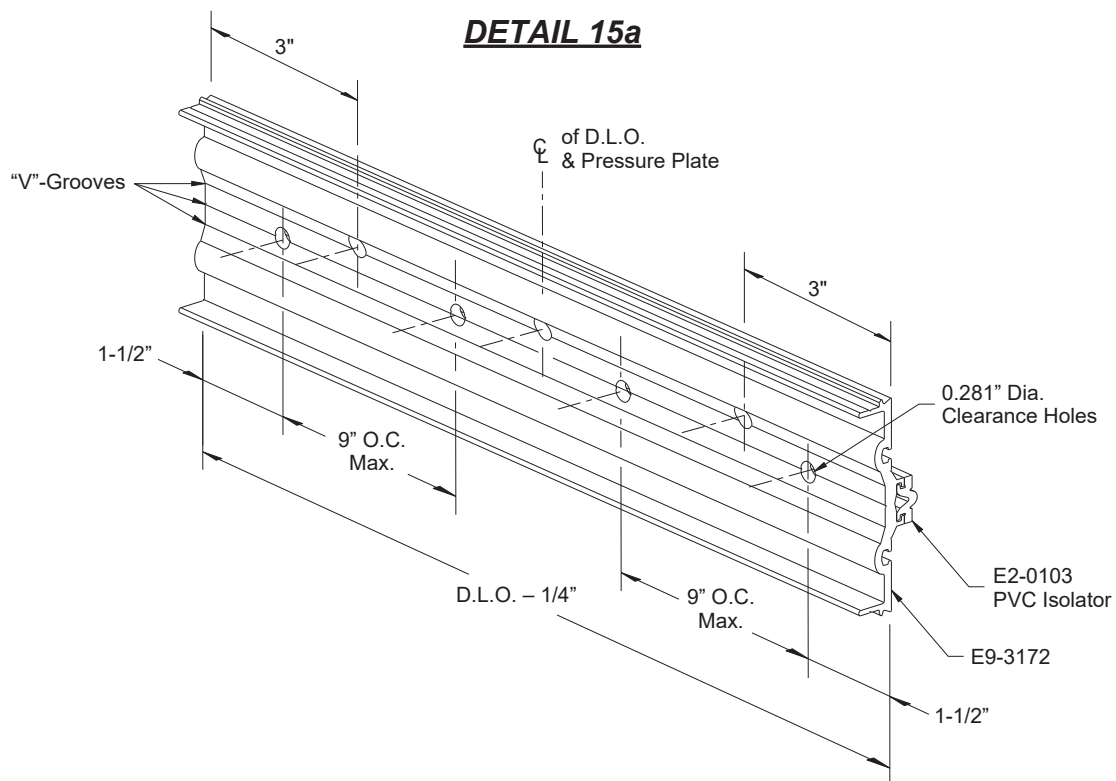

FRAME FABRICATION

STEP 7 (CONTINUED)

FABRICATE HEAD, SILL, AND HORIZONTAL PRESSURE PLATES

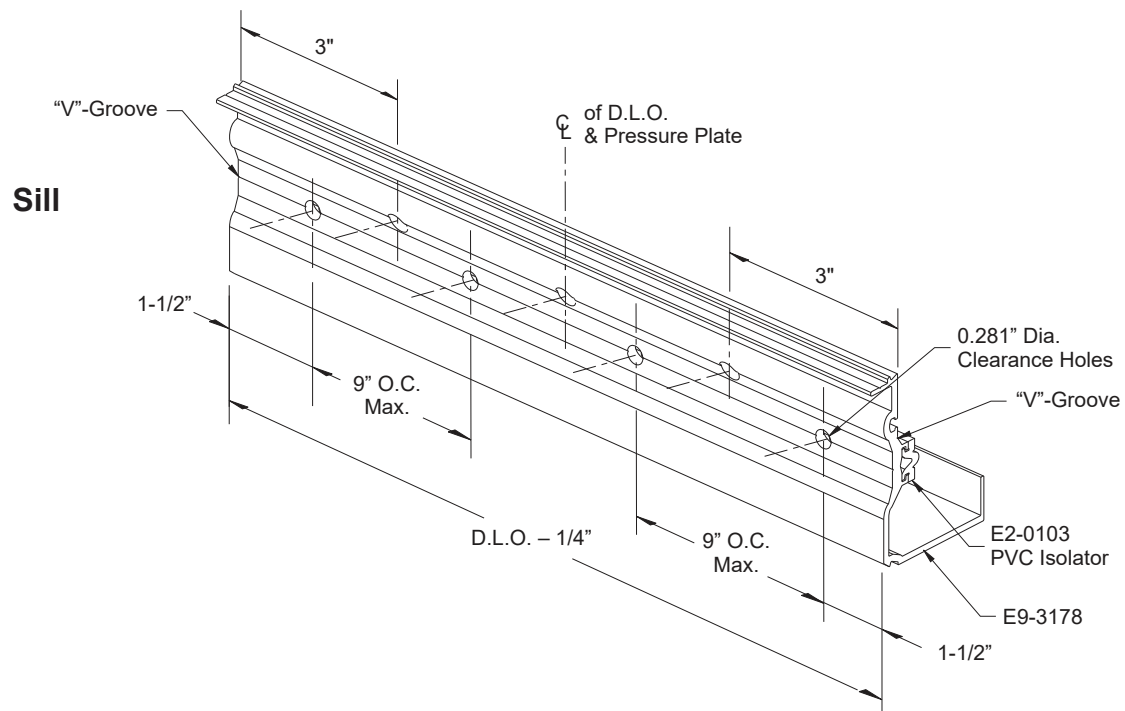
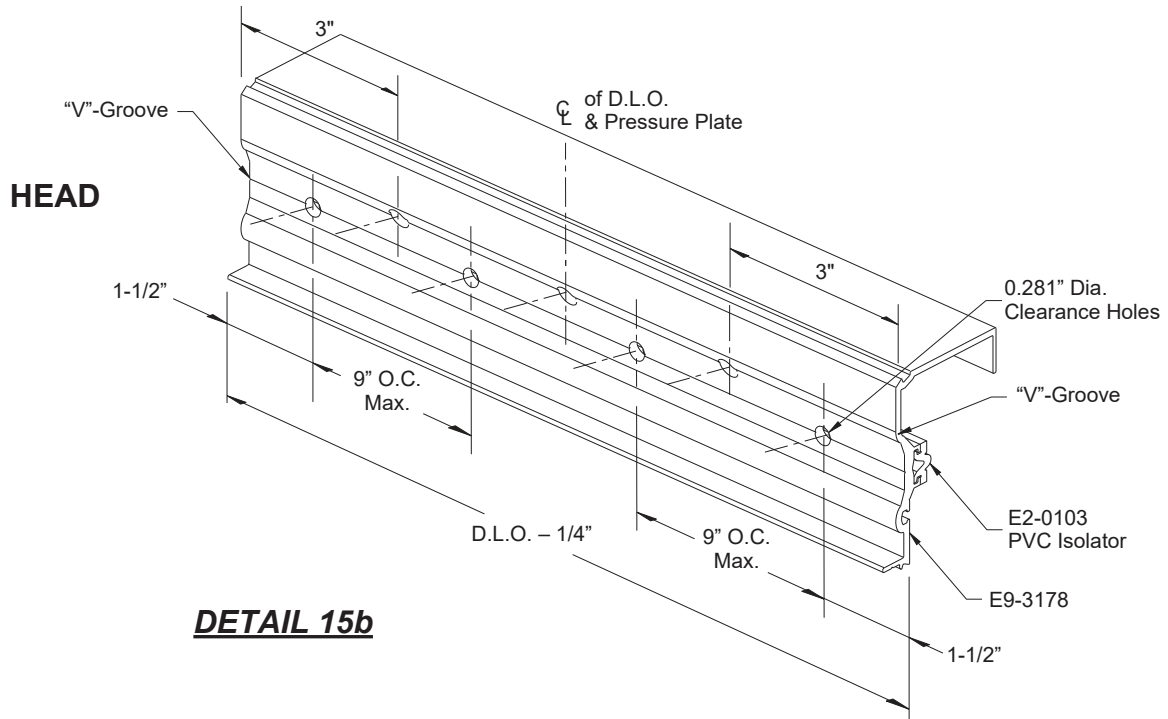

FRAME FABRICATION

STEP 8 FABRICATE VERTICAL PRESSURE PLATES

- Cut vertical and jamb pressure plates to the same length as the mullions unless mullions are spliced.
- If mullions are spliced, cut pressure plates to accommodate for 1/2" expansion joint as shown in **Detail 18** on **Page-32**.
- Drill additional attachment holes if required to ensure that end holes are 1-1/2" from each end.

STEP 9 FABRICATE HORIZONTAL FACE COVERS

- Cut horizontal face covers, E9-3161, to the daylight opening between verticals minus(-) 1/16".
- Drill two 0.313" (5/16") diameter weep holes at 1/3 points of cover as shown.

See **Detail 16**.

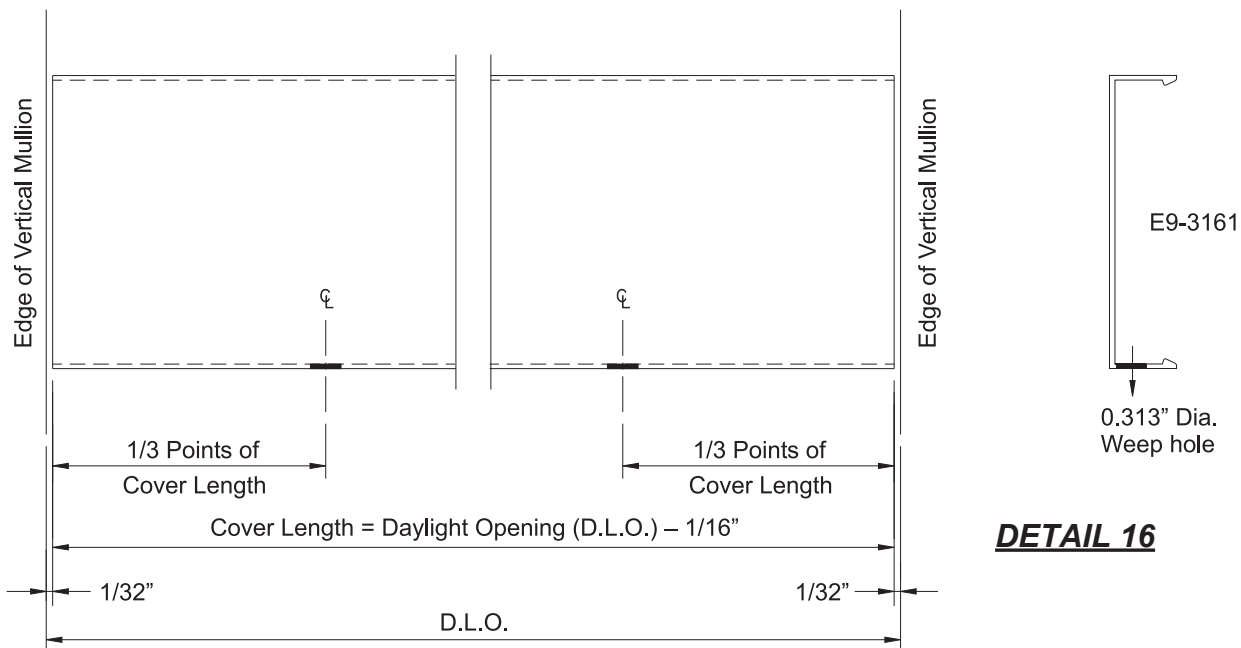

STEP 10 FABRICATE VERTICAL FACE COVERS

- Cut vertical face covers to the same length as the mullions unless the mullions are spliced.
- If mullions are spliced, cut vertical covers to accommodate for the 1/2" expansion joint as shown in **Detail 18** on **Page-32**.

FRAME FABRICATION

STEP 11
FABRICATE MULLIONS FOR SPLICES

Splice locator screw:

- Measure down 2-5/8" on the side of the mullion and mark the hole location.
- Drill a 0.141" diameter (#28 drill bit) diameter hole and countersink for a #8 flat head fastener for the splice locator screw.

Splice sleeve attachment fasteners:

- Measure down from the top of the mullion 1" on both sides and draw a line parallel with the top of the mullion.
- Measure in from both, the front and the back of the mullion, 1-1/2" and mark the hole locations on the previously drawn lines.
- Drill a 0.236" diameter (#B drill bit) diameter hole at each hole location and countersink for a #12 flat head fastener.

Install splice sleeve beveled end up:

- Install one (1) FF-0808 fastener into the side of the mullion to properly locate the splice.
- Carefully slide the splice sleeve down into the end of the mullion with the beveled end up (the beveled end will ease the stacking of the next mullion).
- Match drill 0.189" diameter (#12 drill bit) holes in the splice sleeve through the holes previously drilled in the mullion for the splice sleeve attachment fasteners.
- Attach the splice sleeve with two FC-1212 fasteners on each side of the mullion.

See **Detail 17**.

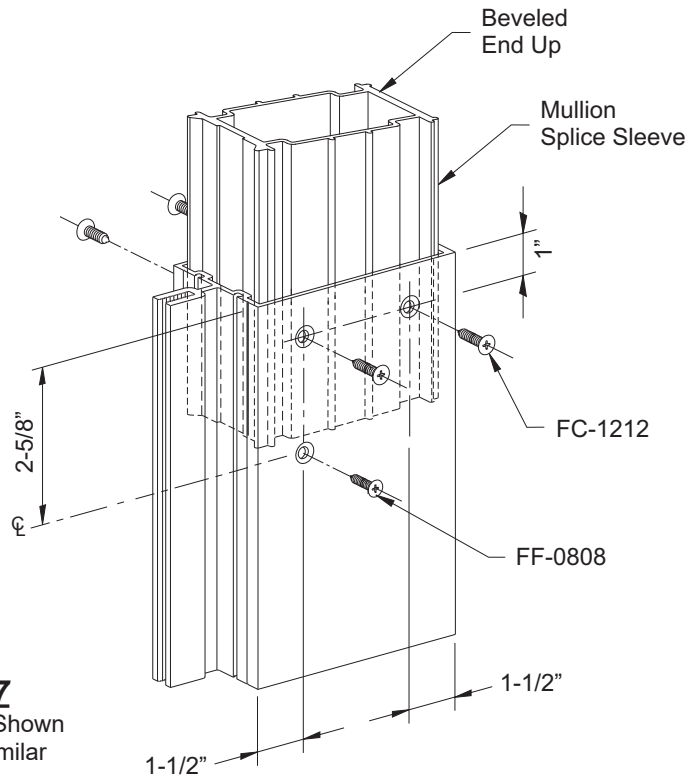

DETAIL 17
Insulating Glazing Shown
Single Glazing Similar

FRAME INSTALLATION

STEP 12 TYPICAL MULLION SPLICE

- Clean all contact surfaces as recommended by sealant manufacturer.
 - Apply bond breaker tape to the face of the mullion splice sleeve.
 - Carefully slide the next mullion down onto the splice sleeve and place a 1/2" temporary shim between the mullions to properly locate them.
 - Secure the upper mullion to the mid anchors and remove the temporary shim.
 - Apply and tool sealant to the face and sides of the splice sleeve to create a water tight joint.
 - Leave a 1/2" expansion joint between vertical pressure plate splices and fill the joint with silicone sealant.
 - Apply bond breaker tape to the face of the cover splice sleeve and attach it to the lower face cover with a FF-0808 fastener on each side.
 - Prior to snapping on the upper portion of the face cover, apply silicone sealant to the face of the cover splice.
 - Leave a 1/2" expansion joint between face cover splices.
- See **Detail 18**.

Note: Face covers, pressure plates, and mullions are staggered at splice locations for proper water shed.

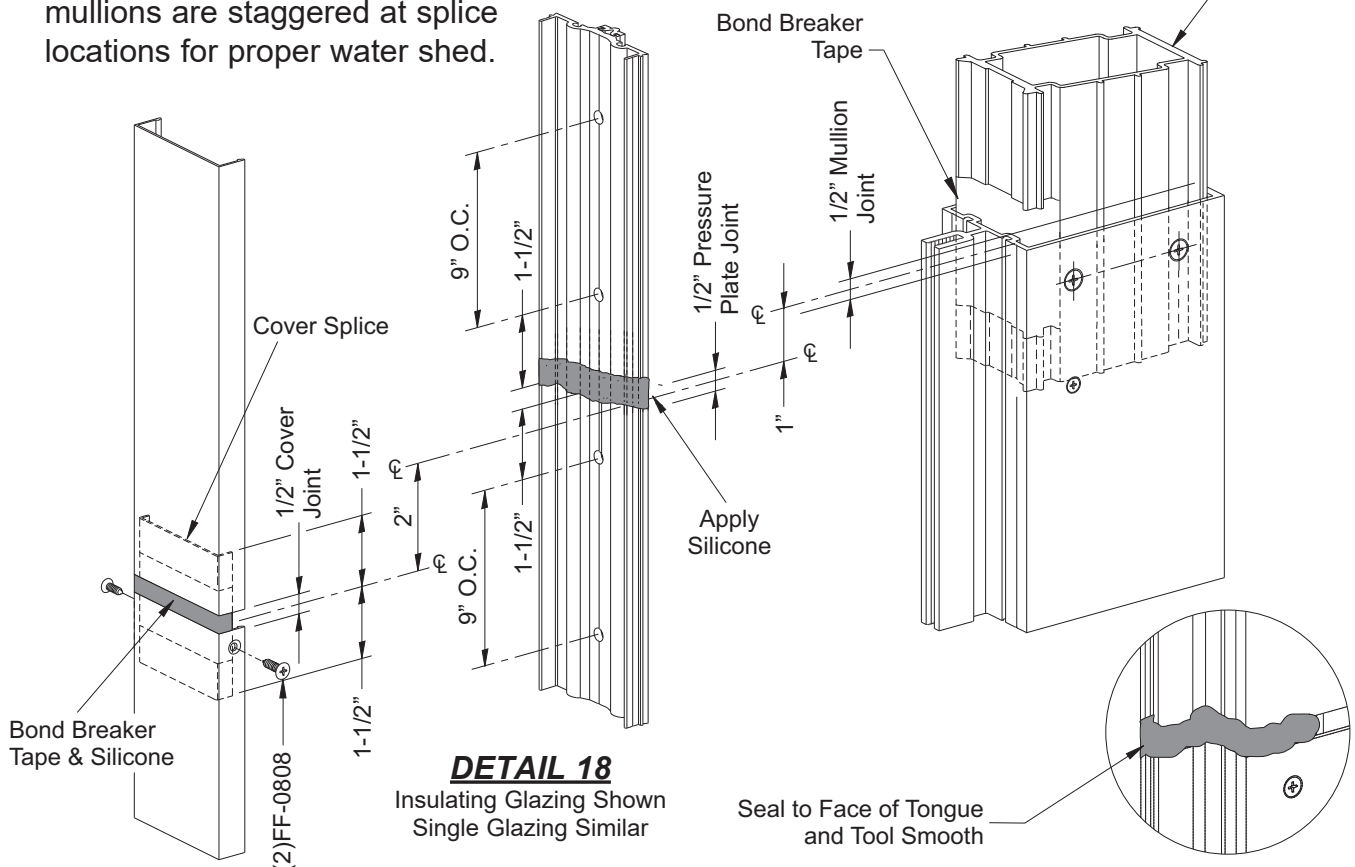
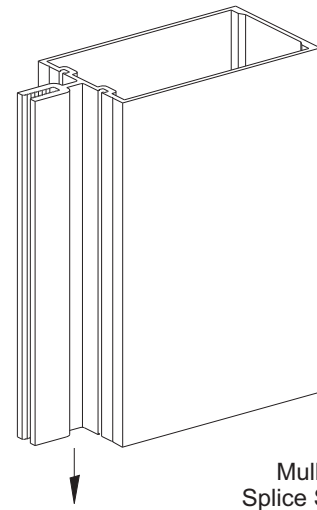

DETAIL 18

Insulating Glazing Shown
Single Glazing Similar

FRAME INSTALLATION

STEP 13
INSTALL MULLION END CAPS

- Clean all contact surfaces as recommended by the sealant manufacturer.
- Apply silicone sealant to screw raceway and edge of mullion prior to installing mullion end caps, E1-3010 for E9-3101 (insulating glazing) or E1-3011 for E9-3103 (single glazing).
- Prior to erecting vertical mullions, install mullion end caps using one FC-1410 fastener at each end of the mullion.
- Apply and tool sealant to all screw heads.

See **Detail 19**.

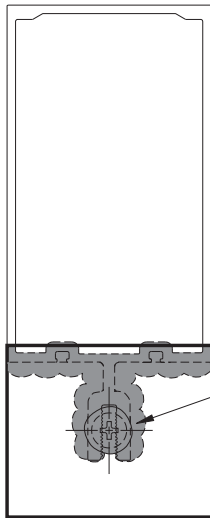
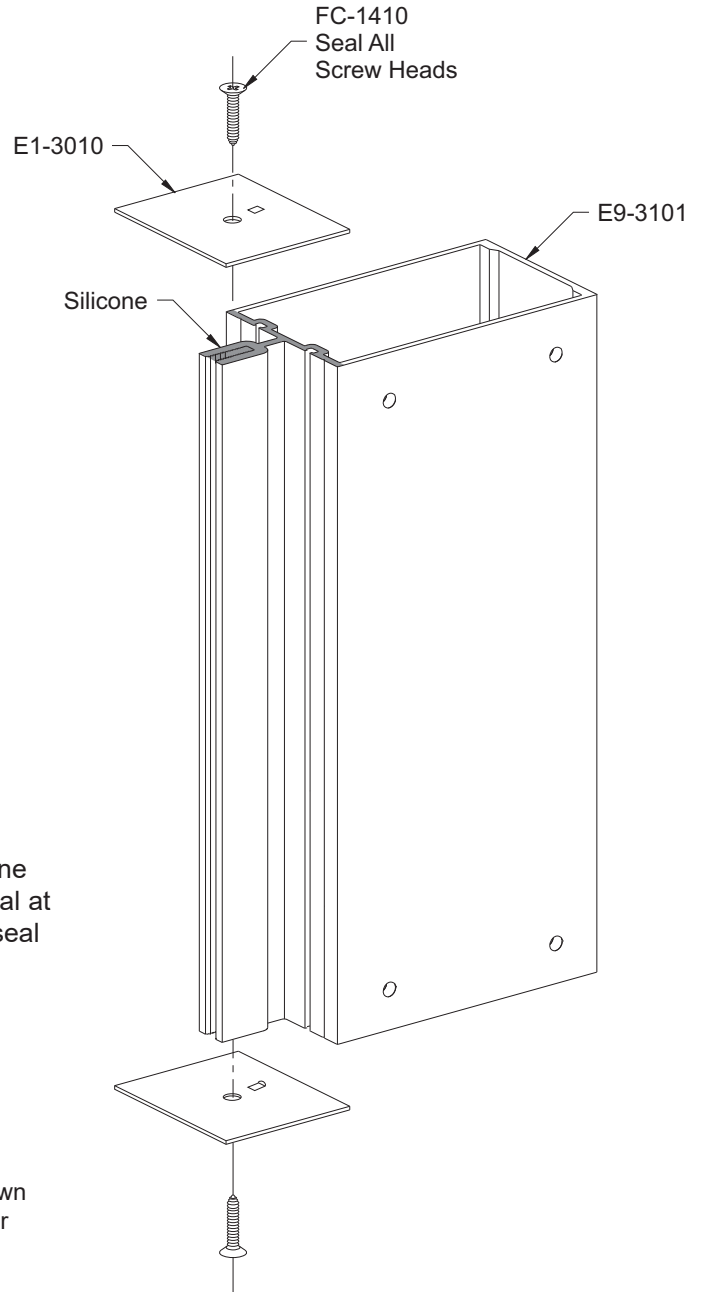

Note:
Seal mullion end cap water tight with silicone sealant around vertical at top and bottom and seal all screw heads.

DETAIL 19
Insulating Glazing Shown
Single Glazing Similar

CAUTION: Make sure that mullion end cap location does not interfere with the installation of mullion end anchors.

FRAME INSTALLATION

**STEP 14
INSTALL JAMB AND INTERMEDIATE MULLIONS**

- Insert mullion "T" anchors and "F" anchors into the top and bottom of the mullions before erecting them into the opening.
- Erect and locate the jamb and intermediate mullions and temporarily attach them to the structure.

Note: All mullions must be installed plumb and true.

- Field drill holes in "T", "F", and "J" anchors for appropriate anchor fasteners according to engineering calculations. Consult YKK AP if load requirements are in question.

See **Detail 20**.

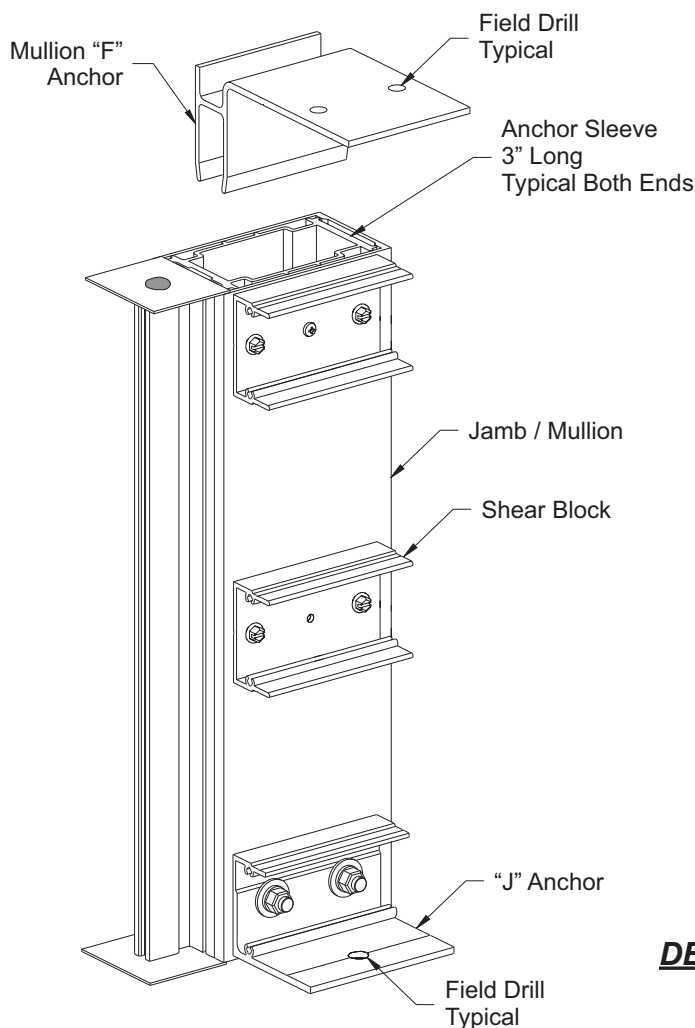
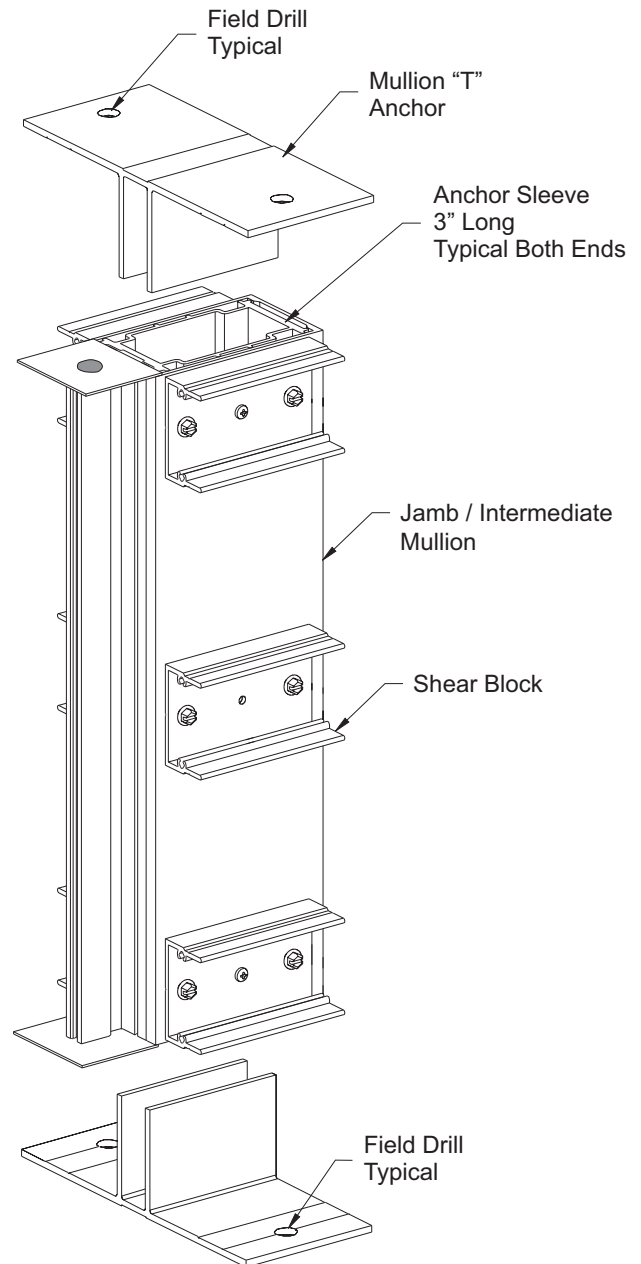

DETAIL 20

FRAME INSTALLATION

STEP 14A
VERTICAL INSTALLATION
AT DOOR JAMB END ANCHORS

The mullions at the door jambs are set directly upon the sill substrate without any shims and are sealed against the substrate. The anchors to be used at this location are specified by the approved shop drawings and or P.E. calculations.

- Locate the mullion anchor for the door jamb and install it to the substrate according to the approved shop drawings and P.E. calculations.
- Clean all contact surfaces as recommended by sealant manufacturer.
- Set the mullion on the anchor, directly onto the sill substrate in a bed of sealant. Avoid using shims at this location. See **Detail 21**.

Note: For single-span elevations, the anchor sleeve must be installed temporarily 6" up from the bottom of the mullion and dropped into place after the mullion is rotated over the side of the door anchor. See **Detail 21A**.

- Refer to the approved shop drawings for any additional fasteners required.
- Tool sealant at the bottom of the mullion at the sill substrate around the perimeter of the mullion. See **Detail 22**.

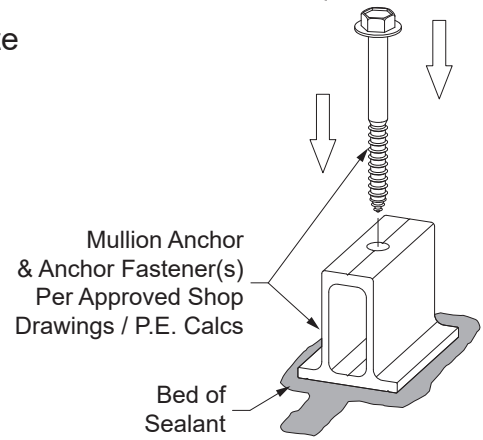
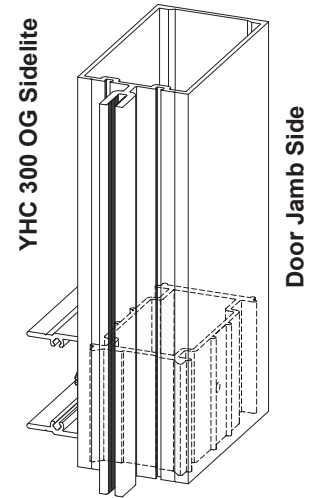

DETAIL 21

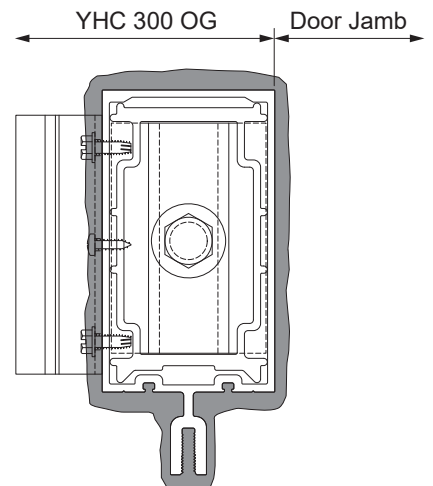
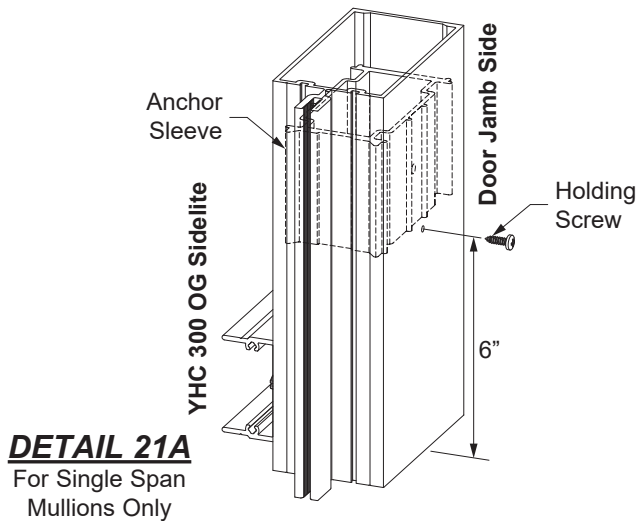

DETAIL 22

FRAME INSTALLATION

**STEP 15
INSTALL WIND LOAD/DEAD LOAD ANCHORS**

- Install steel mullion mid anchors:
Wind Load Anchor. See **Detail 23**.
Dead Load Anchor. See **Detail 24**.

Note: Required anchors and bolt size will vary based on project requirements. Consult a qualified professional engineer or YKK AP.

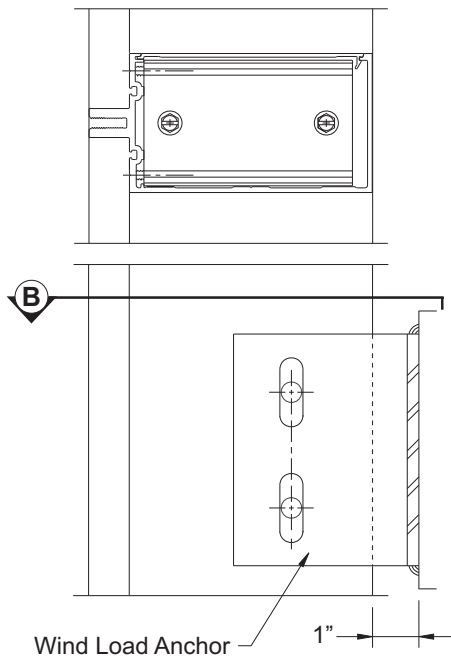

DETAIL 23
Single Glazing Shown
Insulating Glazing Similar

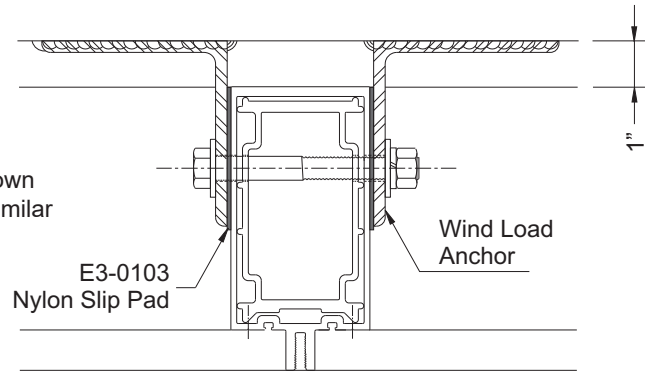

SECTION B

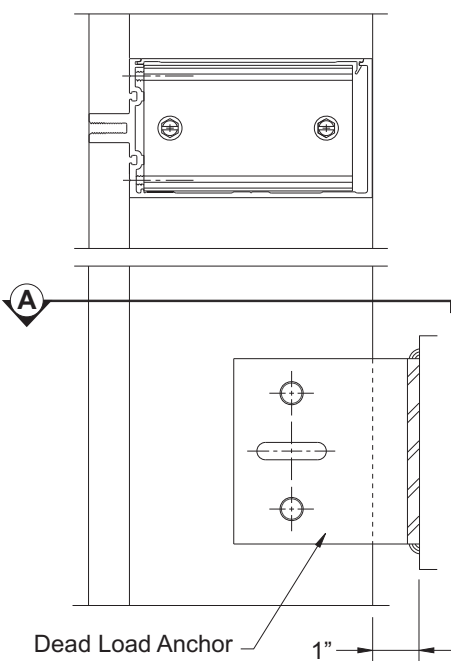

DETAIL 24
Single Glazing Shown
Insulating Glazing Similar

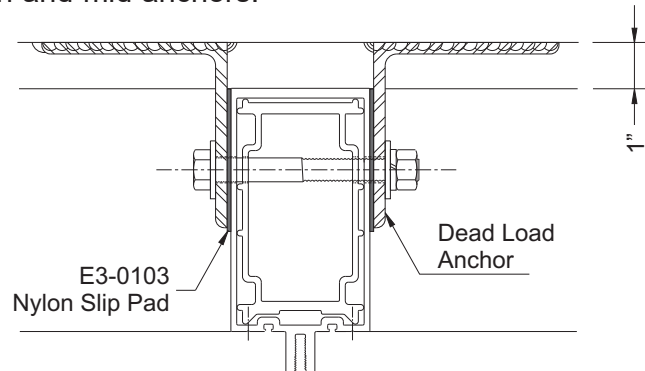

SECTION A

- Mid anchors are normally template or line set before mullions are hung.
- Slotted or drilled leg of clip must be set at 90° to offset leg.
- See shop drawings for details of mid anchor attachment.
- Install plumb and align vertical mullions, drill appropriate size holes for anchor bolts as shown in shop drawings.
- Anchor bolts are fastened **after** horizontals are attached.
- Nylon slip pads, E3-0103, **must** be installed between mullion and mid anchors.

FRAME INSTALLATION

STEP 15 (CONTINUED) INSTALL WIND LOAD/DEAD LOAD ANCHORS

-Refer to shop drawings or engineering calculations for anchor requirements.

TYPICAL WINDLOAD ANCHOR

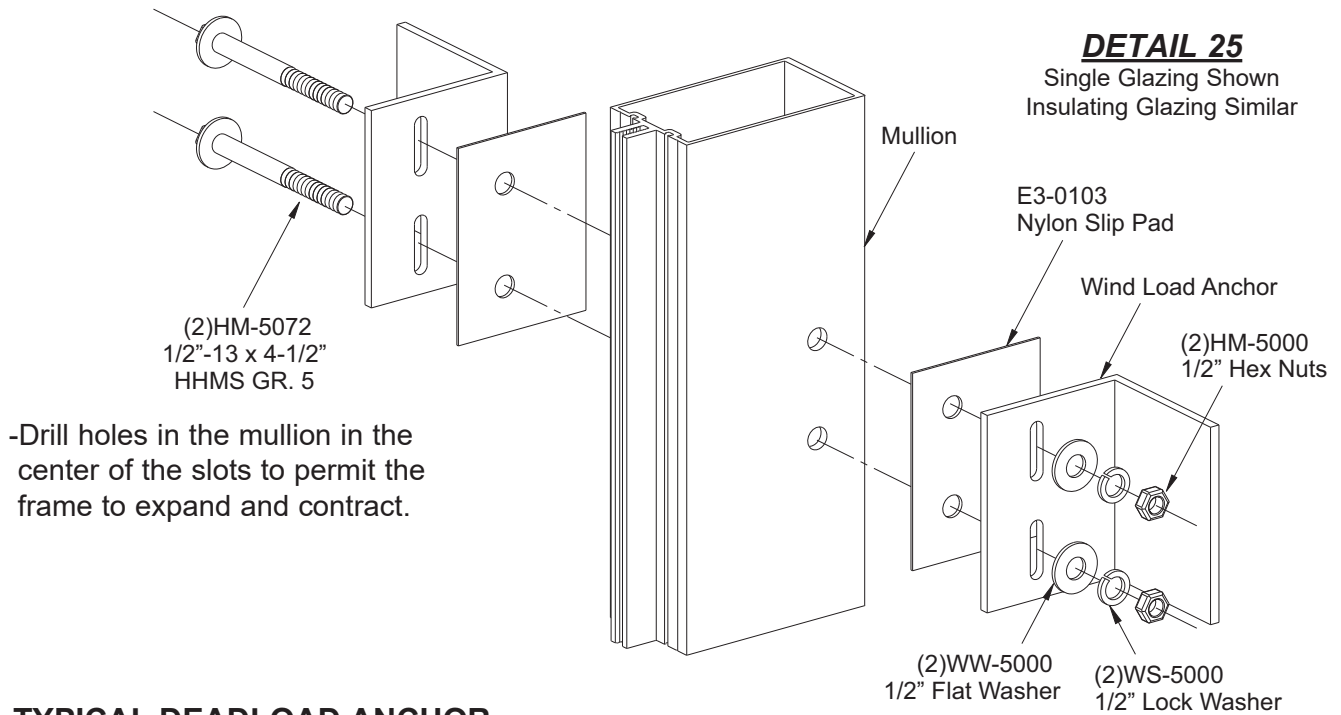

-Drill holes in the mullion in the center of the slots to permit the frame to expand and contract.

TYPICAL DEADLOAD ANCHOR

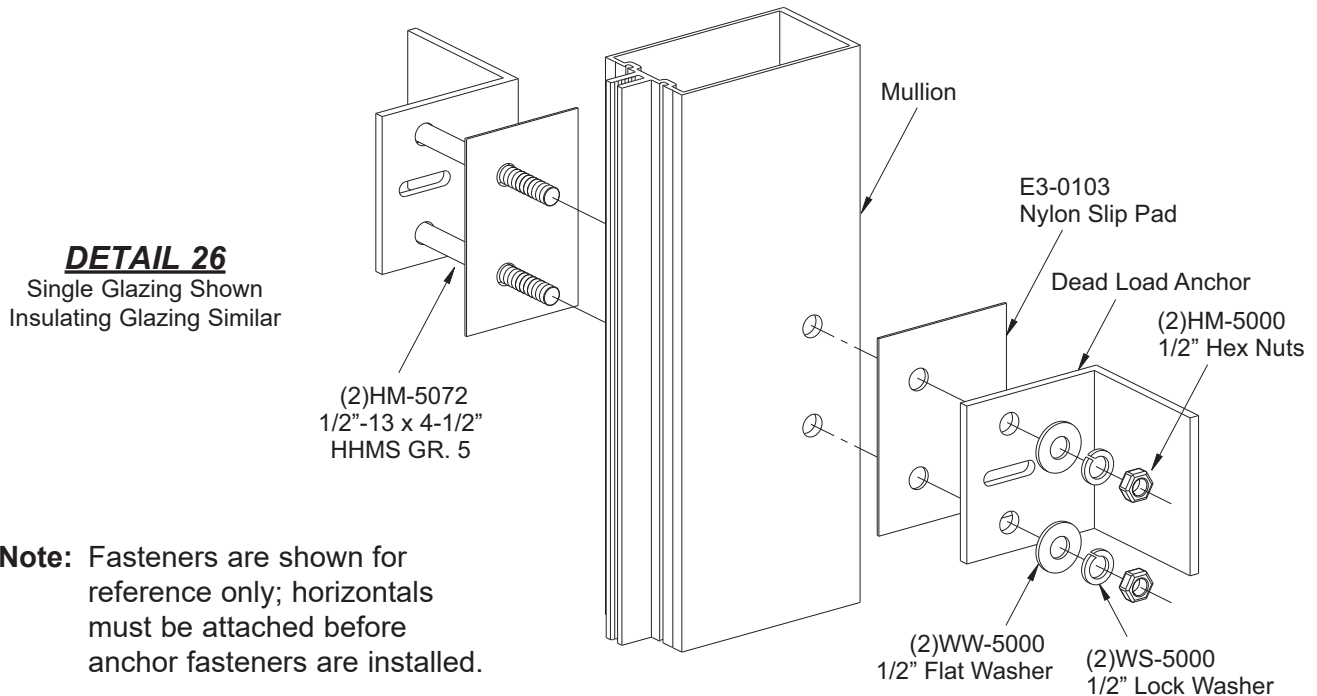

Note: Fasteners are shown for reference only; horizontals must be attached before anchor fasteners are installed.

FRAME INSTALLATION

STEP 15 (CONTINUED)

INSTALL WIND LOAD/DEAD LOAD ANCHORS

-Refer to shop drawings or engineering calculations for anchor requirements.

JAMB WIND LOAD ANCHOR

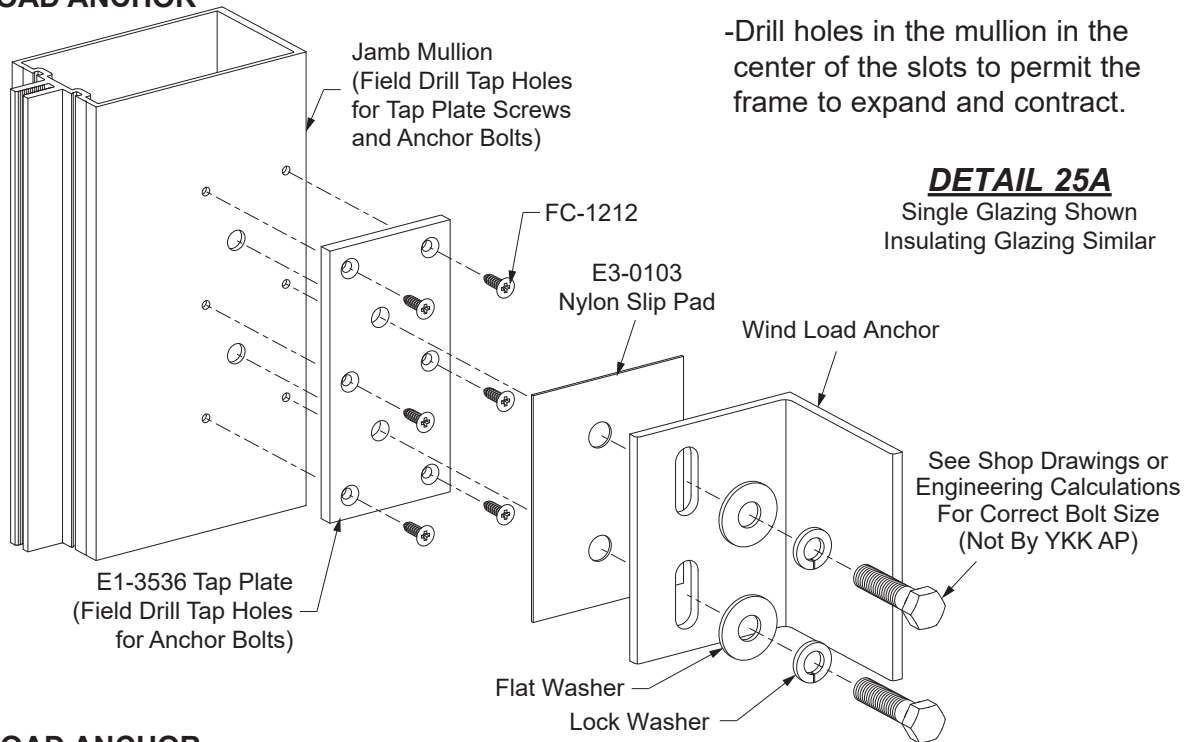

JAMB DEAD LOAD ANCHOR

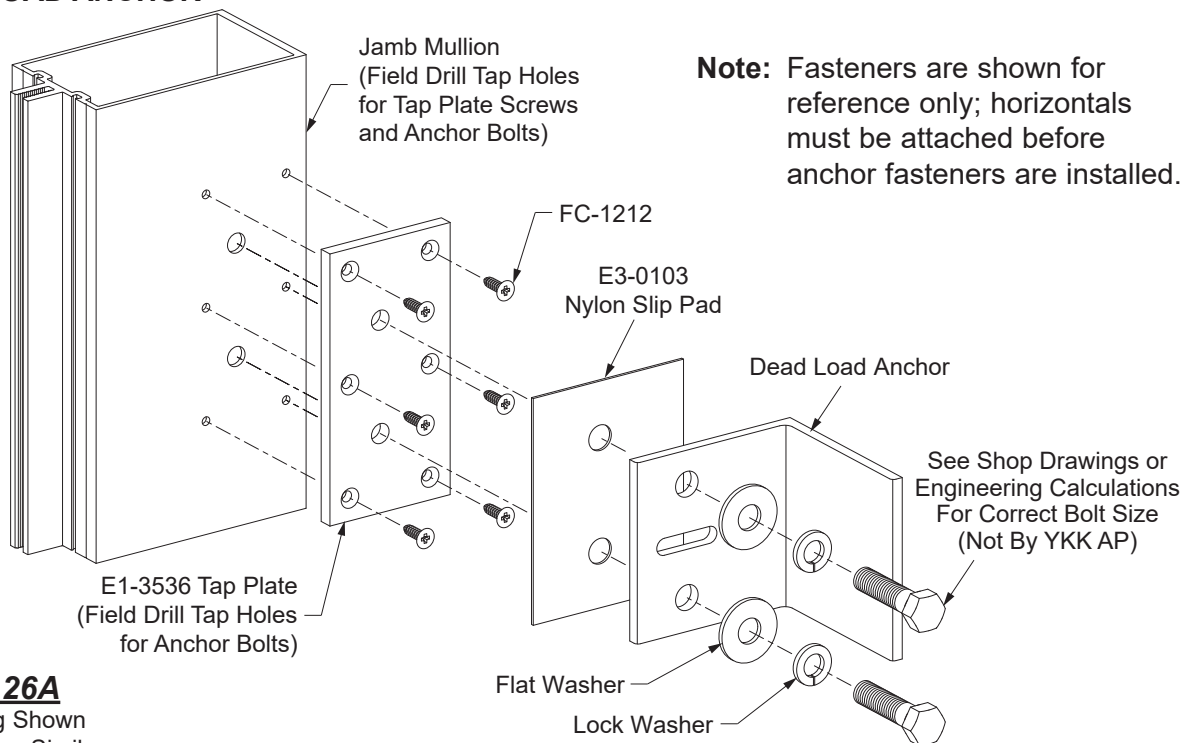

DETAIL 26A

Single Glazing Shown
Insulating Glazing Similar

FRAME INSTALLATION

STEP 16 ATTACH HORIZONTAL MEMBERS

Note: Before applying any sealant, clean aluminum surfaces using cleaner and method approved by silicone sealant manufacturer.

- Just prior to attaching the horizontal members to the vertical, apply sealant to the front of the shear block as shown.
- Slide the horizontal members towards the shear blocks and attach them with two FC-1220 fasteners at each end.
- Tool and wipe away any excess sealant.

See **Detail 27**.

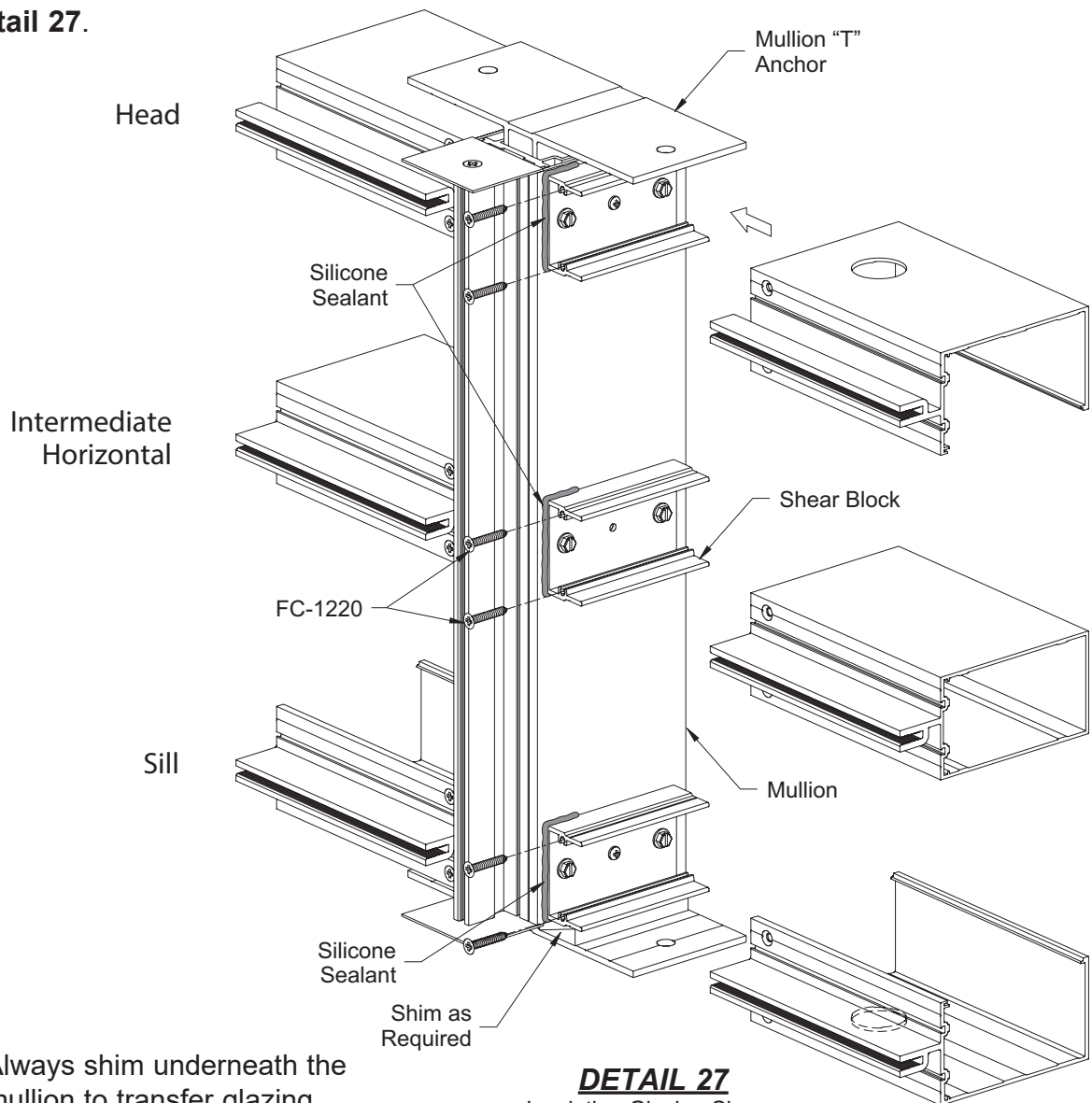

Note: Always shim underneath the mullion to transfer glazing dead loads to the foundation.

DETAIL 27
Insulating Glazing Shown
Single Glazing Similar

FRAME INSTALLATION

STEP 16 (Continued) ATTACH HORIZONTAL MEMBERS

- Drill appropriate size holes into the structure for the anchor fasteners.
- Provide anchor fasteners as per job requirements. See approved shop drawings or engineering calculations for appropriate anchor fasteners.
- Install the anchor fasteners.

Caution: There must always be a shim under the mullion to transfer glazing dead loads to the foundation.

- Install the flush filler after tightening the anchor fasteners.

See **Detail 28**.

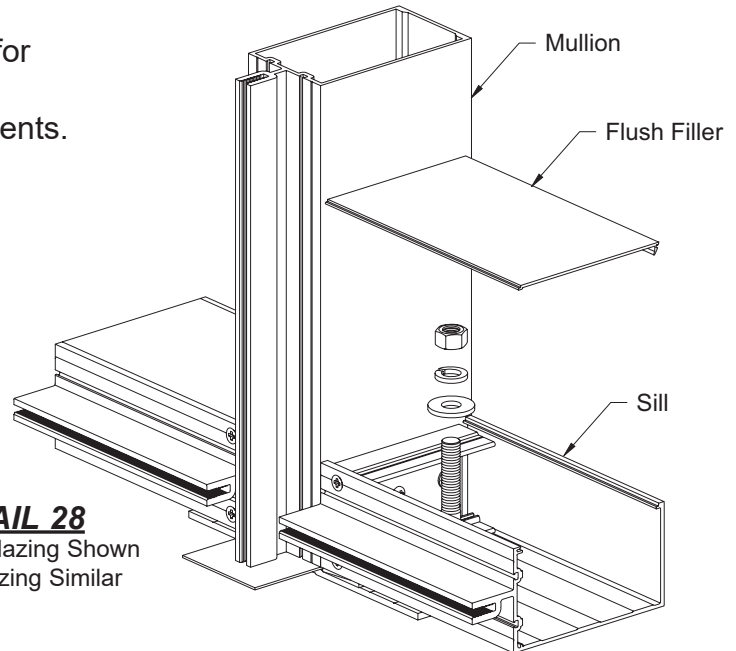

DETAIL 28
Insulating Glazing Shown
Single Glazing Similar

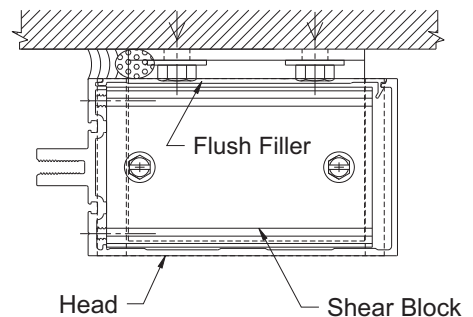
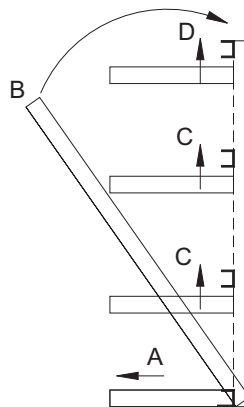
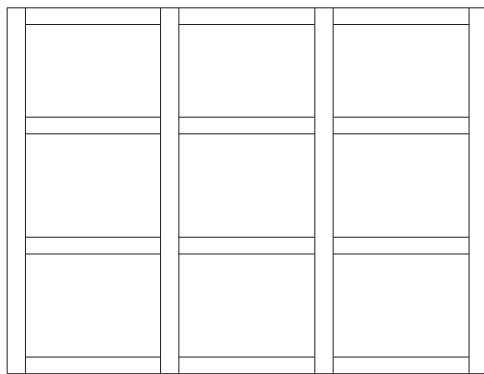

DETAIL 29
Single Glazing Shown
Insulating Glazing Similar

Horizontal Attachment at End Bays:

- A: Bring the horizontal members into position and secure loosely.
- B: To install vertical jamb, engage bottom shear block or “J” anchor with the sill member. Pivot vertical jamb member into position and anchor loosely.
- C: Use open back horizontal members at intermediate locations, bring them from under the shear clips and lift into position. Fasten the horizontals to the shear blocks.
- D: Secure top and bottom end anchors permanently; then install the head member with the open side facing up to clear the shear blocks. Fasten the head member to the shear blocks.

See **Detail 29**.

FRAME INSTALLATION

STEP 17
90° OUTSIDE CORNER ASSEMBLY

- Locate both vertical mullions perpendicular to each other as shown in **Detail 29**.
- Anchor head and sill ends with appropriate end anchors - “J”, “F”, or “T”.
Refer to shop drawings for wind load / dead load anchors.
- Position angle E9-9303 into corner between the two vertical mullions and fasten both legs every 12” on center (o.c.) using PC-1010 fasteners.
- Position 1/8” formed aluminum cover between the verticals and install temporary pressure plates every two to three feet to hold the aluminum cover in place.
- Fasten the aluminum cover to the face of the mullion every 18” on center (o.c.) with 3/4” long #10 Tek screws.
- Seal all exposed screw heads and remove the temporary pressure plates.
- Do not span formed aluminum cover more than 12’-6” ; leave 1/2” joint between spans of 12’-6”.
- Clean area around joint with isopropyl alcohol (50%) and wipe clean with lint free cotton cloths using the “two cloth method”.
- Compress backer rod into the 1/2” joint. Apply and tool silicone sealant to the joint.

See **Detail 30**.

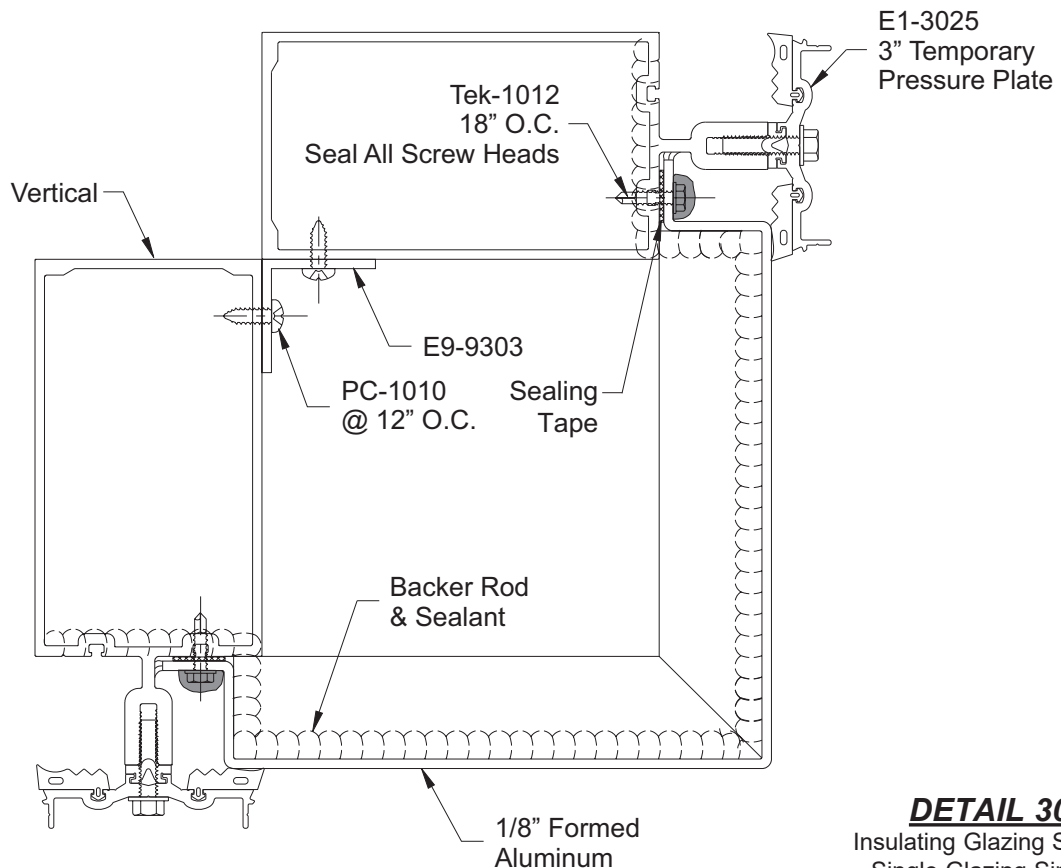

DETAIL 30
Insulating Glazing Shown
Single Glazing Similar

FRAME INSTALLATION

STEP 17

90° INSIDE CORNER ASSEMBLY

- Locate both vertical mullions as shown in **Detail 31**.
- Anchor head and sill ends with appropriate end anchors - "J", "F", or "T".
Refer to shop drawings for wind load / dead load anchors.
- Position 1/8" formed aluminum cover between the verticals and fasten to mullions with PC-1010 at 12" on center. Seal the screw heads.
- Position angle E9-9303 and at the end of the mullions as shown in **Detail 31**, and fasten with PC-1010 at 12" on center.
- Fasten the aluminum closure to angle E9-9303 every 18" on center (o.c.) with 3/4" long #10 Tek screws.
- Do not span formed aluminum cover more than 12'-6"; leave 1/2" joint between spans of 12'-6".
- Clean area around joint with isopropyl alcohol (50%) and wipe clean with lint free cotton cloths using the "two cloth method".
- Compress backer rod into the 1/2" joint. Apply and tool silicone sealant to the joint.

See **Detail 31**.

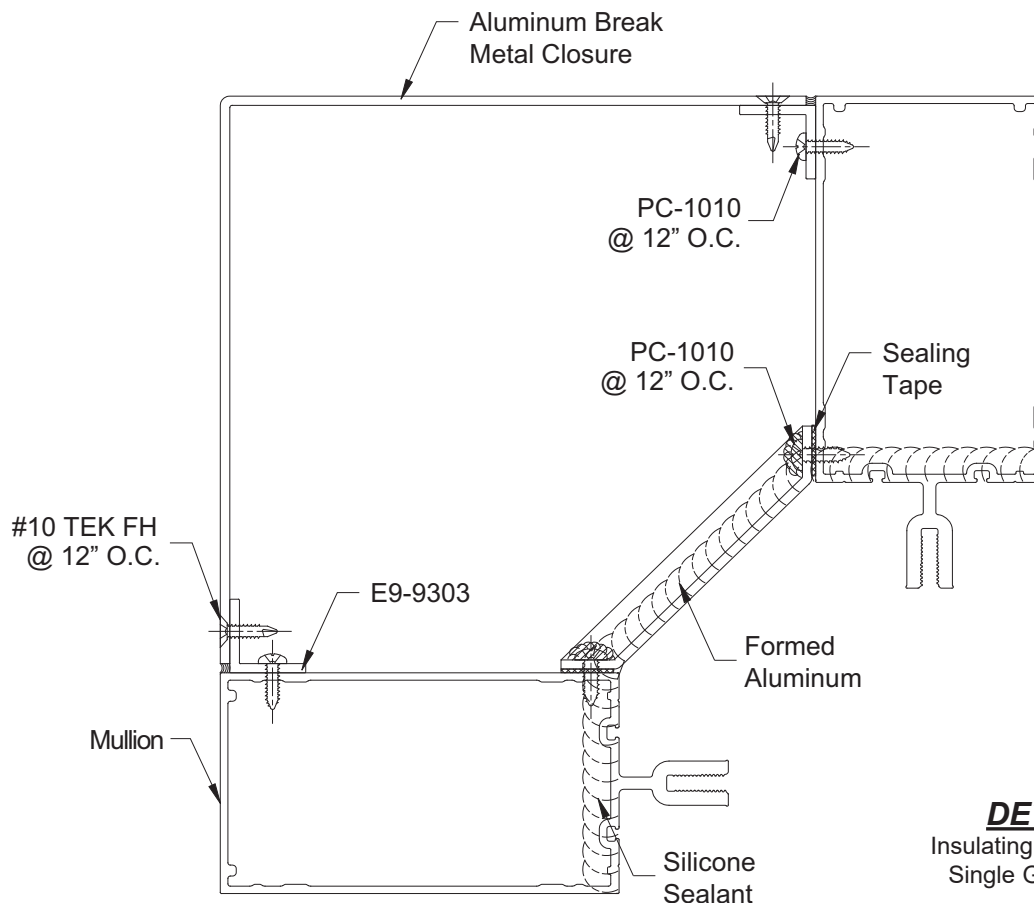

DETAIL 31
Insulating Glazing Shown
Single Glazing Similar

FRAME INSTALLATION

STEP 17
INSTALL DOOR SUBFRAMES

Refer to the **35H/50H Door Installation Manual** for assembly of the door subframes. These subframes are installed into the curtain wall framing members. The subframe members are determined by the approved shop drawings.

-Clean all sealant contact surfaces as recommended by the sealant manufacturer.

-Install the jamb subframe onto the mullion with fasteners according to the approved shop drawings and/or P.E. calculations. For air-resistant thresholds, set the jamb subframes in a bed of sealant at the floor substrate.

-Apply and tool sealant between the door jamb subframe and the curtain wall framing. For air-resistant thresholds, apply and tool sealant to the bottom of the jamb subframe as shown in **Details 33 & 34**.

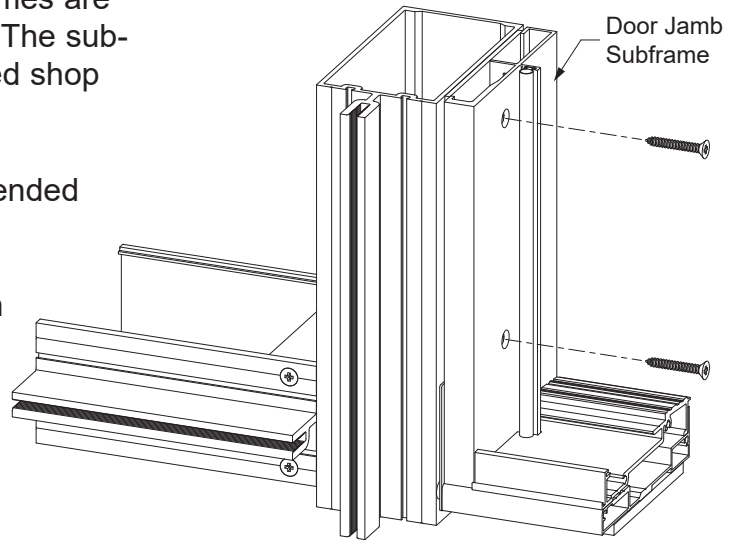

Detail 32
Water-resistant
Threshold Shown

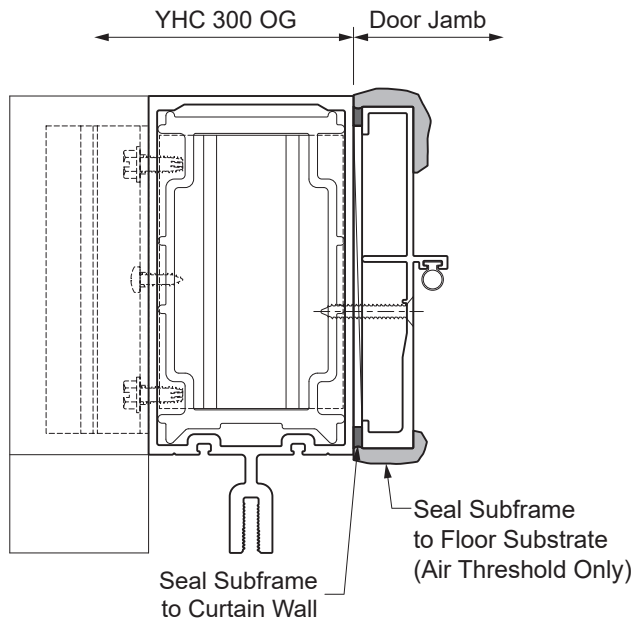

Detail 33

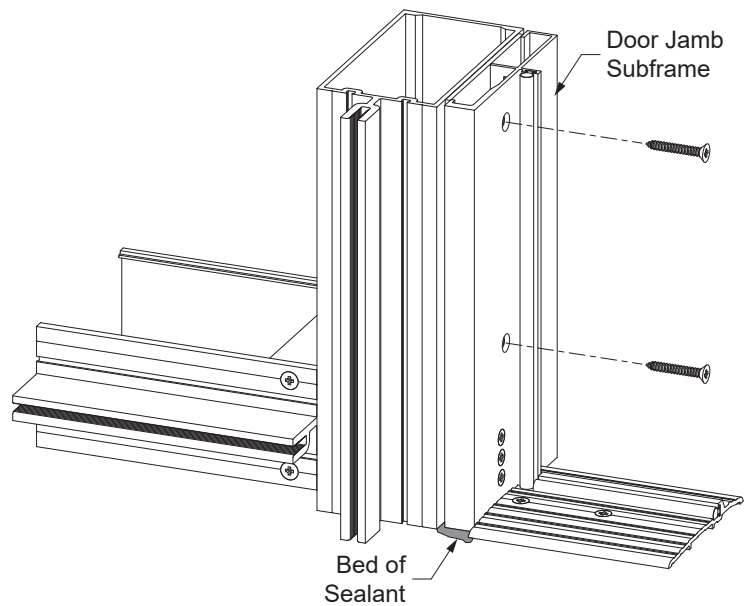

Detail 34
Air-resistant
Threshold Shown

FRAME INSTALLATION

**STEP 18
APPLY PERIMETER SEALANT**

- Position backer rod around the perimeter of the frame.
- Clean area around the perimeter of the frame with isopropyl alcohol (50%) and wipe clean with lint free cotton cloths using the “two cloth method”.
- Apply silicone sealant to the perimeter of the frame.

See **Detail 35**.

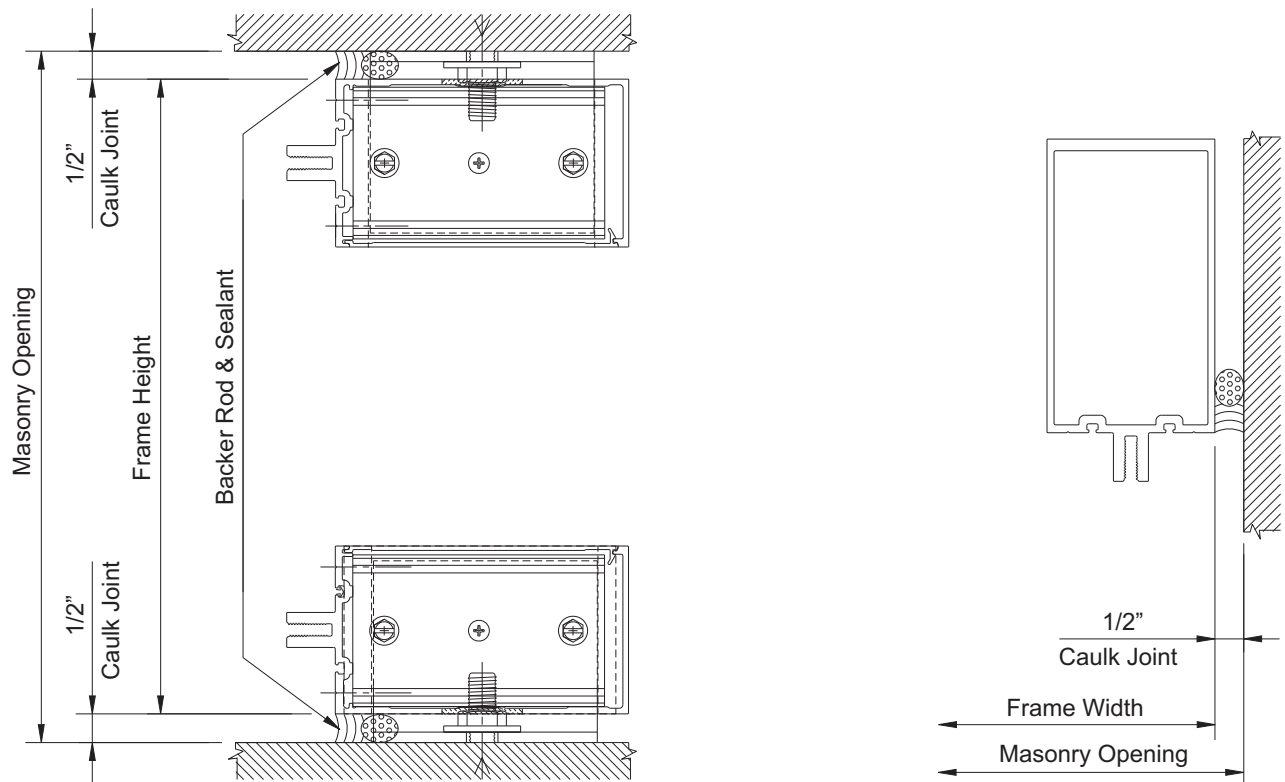

DETAIL 35
Single Glazing Shown
Insulating Glazing Similar

GLAZING

**STEP 19
INSTALL 1/4" GLAZING ADAPTORS (When Required)**

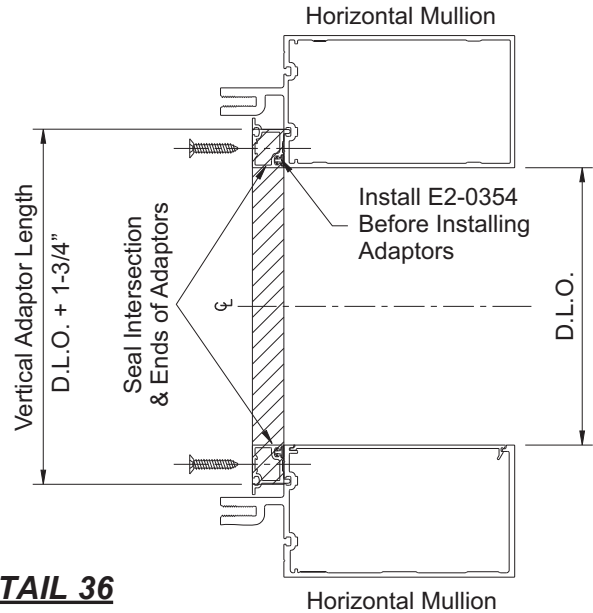
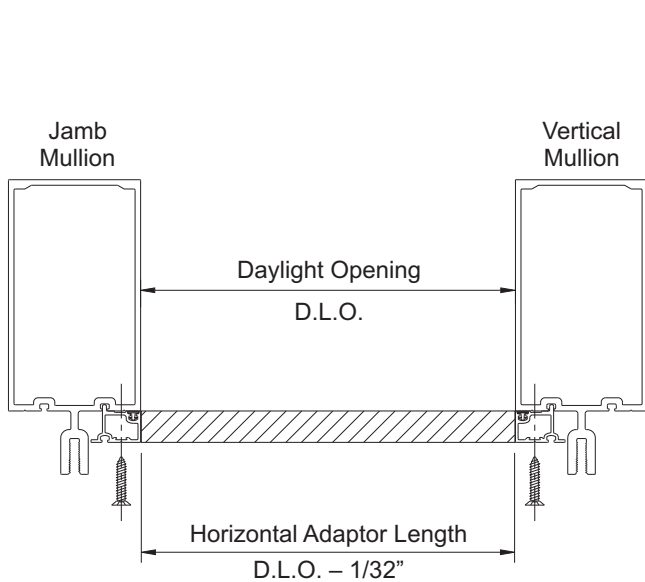

DETAIL 36

- Cut glazing adaptors for verticals:
Cut Length = D.L.O. plus(+) 1-3/4".
- Cut glazing adaptors for horizontals:
Cut Length = D.L.O. minus(-) 1/32".

- Slide bulb gasket, E2-0354, into the reglet at the back of the glazing adaptors.
- Predrill 0.213" dia. holes countersunk for #10 fastener along the "V"-groove of each adaptor: 2" from each end and 18" on center or as directed by P.E. calculations.
- Center the vertical glazing adaptors along the opening as shown.

- Dry fit the glazing adaptors and match drill 0.161" dia. holes in the mullion.
- Remove the glazing adaptors and apply silicone sealant over the drilled holes.
- Reinsert the adaptors and secure them to the mullions with FC-1016 fasteners.
- Install vertical adaptors first and butter each end of the horizontal adaptors with silicone sealant before installing them.

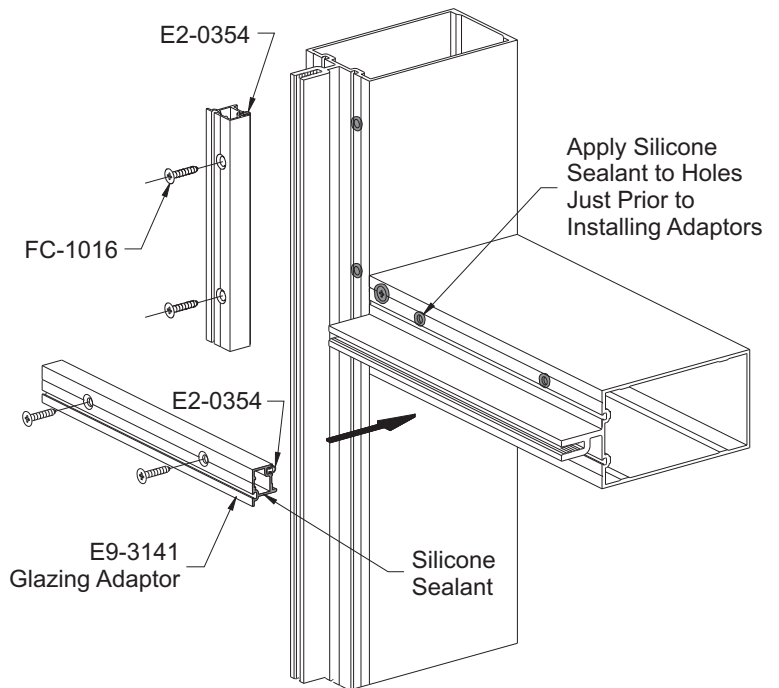

DETAIL 37

See **Details 36 & 37.**

GLAZING

**STEP 20
INSTALL JOINT PLUGS**

The tongue of all horizontals must be sealed to the tongue of the mullion.
The space between the two tongues is plugged with joint plugs, E2-0355 for insulating glazing or E2-0358 for single glazing.

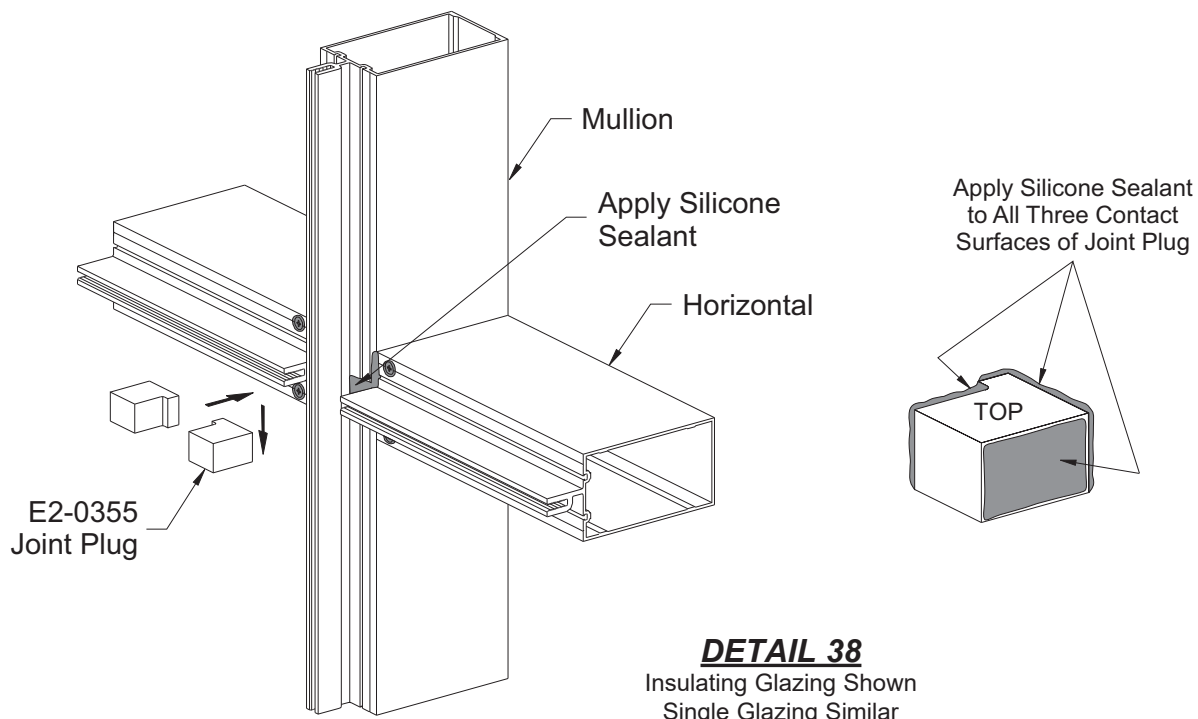

- Clean the mullion to horizontal joints with a cleaner and method as approved by sealant manufacturer.
- Apply and tool tested silicone sealant to the vertical to horizontal joints.
- Apply silicone sealant to all three contact sides of the joint plugs.
- Apply silicone sealant into all cavities directly behind where each joint plug will go.
- Insert the joint plugs into the opening and press them firmly against the face of the mullions.

See **Details 38 & 39**.

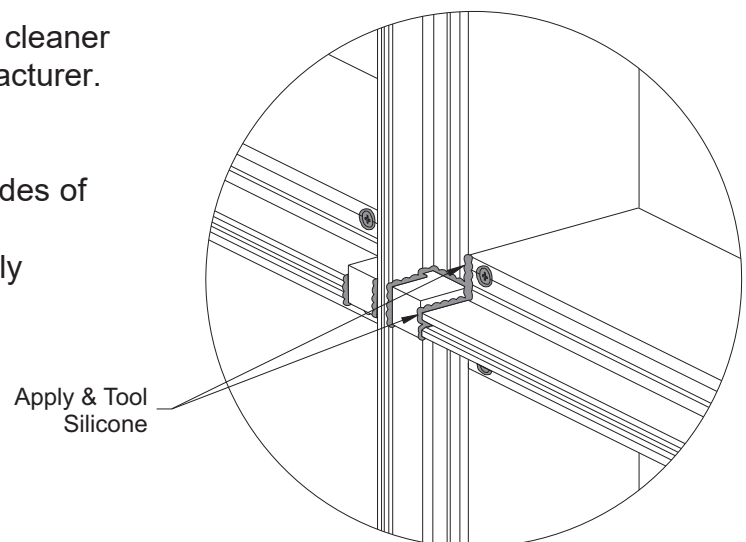

GLAZING

STEP 21 INSTALL STRUCTURAL GLAZED INTERIOR GLAZING SPACERS

For applications below 90 PSF

- Cut interior vertical glazing spacers, E2-0353, to daylight opening plus(+) 2".
 - Cut the horizontal glazing spacers, E2-0353, to daylight opening plus(+) 1-1/4".
 - Trim off 5/8" of the glazing dart at each end of the horizontal glazing spacers.
- See **Detail 40**.

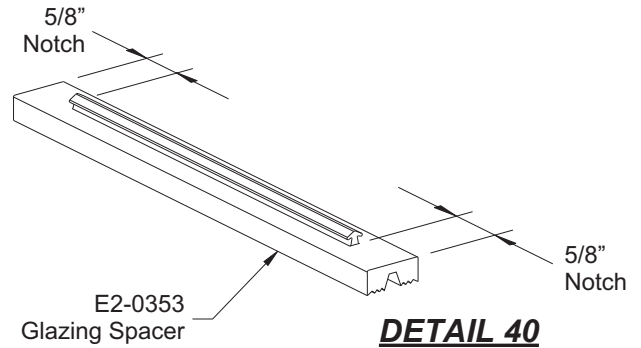

For applications above 90 PSF

- Cut interior vertical glazing spacers, E2-0222, to daylight opening plus(+) 2".
 - Cut the horizontal glazing spacers, E2-0222, to daylight opening plus(+) 1-3/4".
 - Trim off 7/8" of the glazing dart at each end of the horizontal glazing spacers.
- See **Detail 41**.

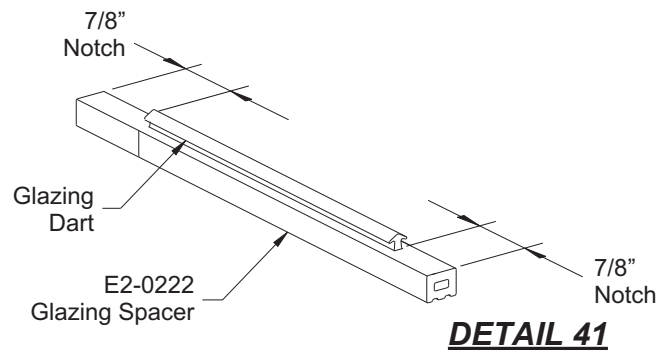

- Install vertical glazing spacers first:
 - Install vertical glazing spacer centered along the daylight opening.
 - Insert the spacer into the reglet starting at the center and work towards each end.

Note: Do not stretch the glazing spacer while installing it into the reglet.

- Install horizontal glazing spacers next:
 - Insert the glazing spacer into the reglet at each end first.
 - Install the rest of the glazing spacer into the reglet starting at the center and work towards each end.

Note: Horizontal spacer ends should always butt into the vertical spacer.

See **Detail 42**.

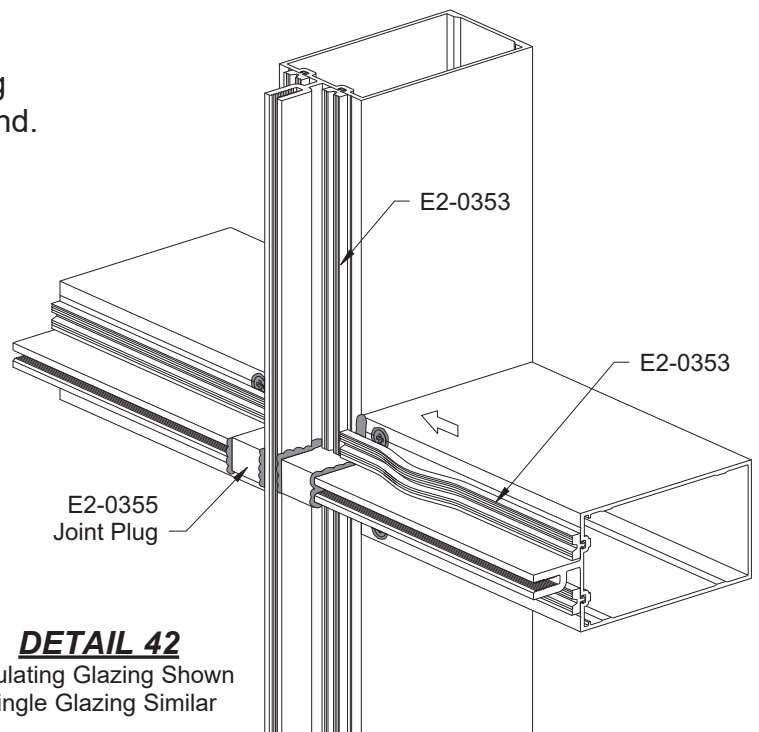

DETAIL 42

Insulating Glazing Shown
Single Glazing Similar

GLAZING

STEP 22

INSTALL INTERIOR DRY GLAZED GLAZING GASKETS

- Cut vertical glazing gaskets, E2-0379, to daylight opening plus(+) 2”.
- Cut the horizontal glazing gaskets, E2-0379, to daylight opening plus(+) 3/16” for each foot of opening width.

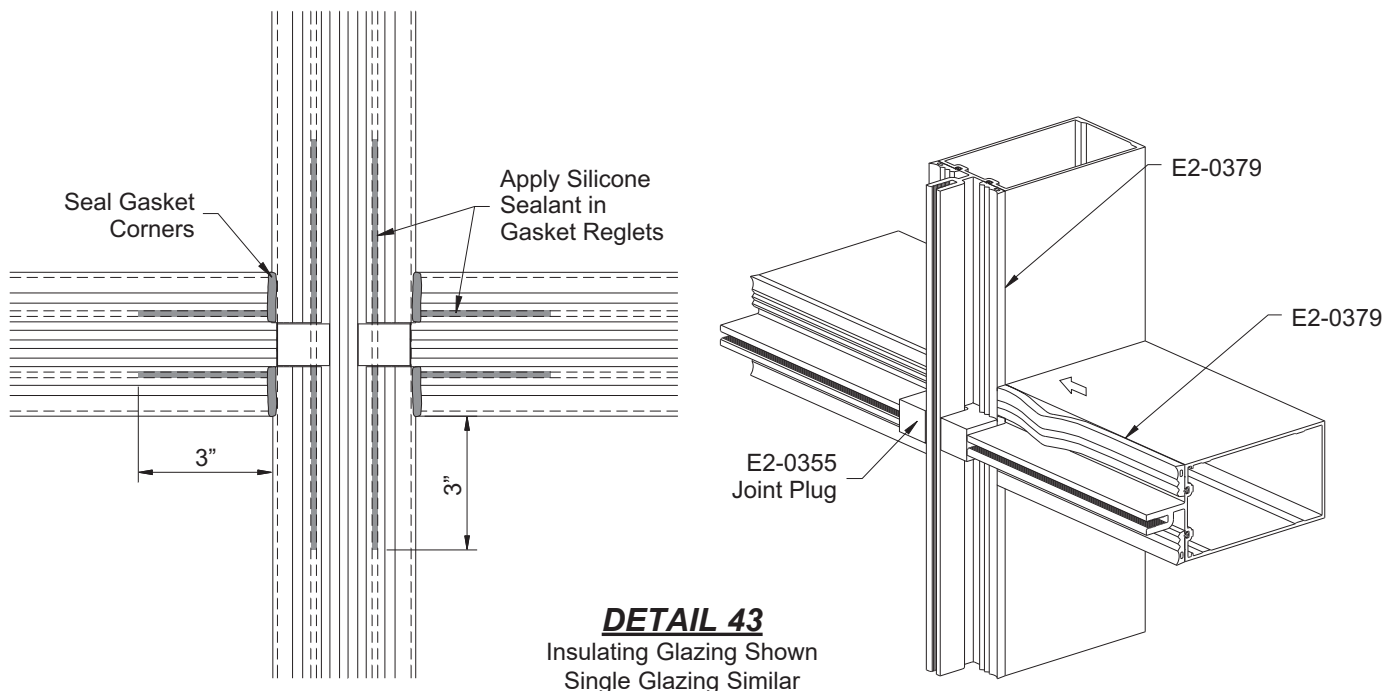

- Just prior to installing the gaskets, apply silicone sealant to the gasket reglets at the horizontal / vertical intersections as shown in **Detail 43**.
- Install vertical glazing gaskets first:
 - Install vertical glazing gasket centered along the daylight opening.
 - Insert the gasket into the reglet starting at the center and work towards each end.
- Install horizontal glazing gaskets next:
 - Apply silicone sealant to both ends of the horizontal glazing gasket.
 - Insert the glazing gasket into the reglet at each end first. Then install the rest of the glazing gasket into the reglet starting at the center and work towards each end.
 - Tool the excess sealant at the gasket corners to ensure a watertight seal.

Note: Do not stretch the glazing gasket while installing it into the reglet.

See **Detail 43**.

GLAZING

**STEP 23
INSTALL GLASS**

- Clean all glazing surfaces and joints of foreign matter and contaminants such as grease, oil, dust, frost, and surface dirt. Do not use water or soap to clean surfaces or to tool the sealant.
- Install setting blocks, E2-0611 for insulating glazing or E2-0623 for single glazing, at 1/4 points of horizontal.
- Install side blocks, E2-0537, centered along the daylight opening on both sides of the glazing material.

See **Detail 44**.

DETAIL 44
Insulating Glazing Shown
Single Glazing Similar

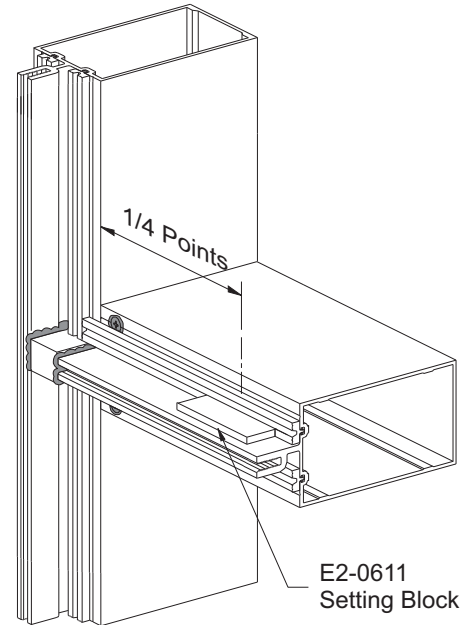

- Clean all silicone contact surfaces and joints with a cleaner and method as approved by sealant manufacturer.
- Carefully install glass into the frame. Make sure setting blocks and spacers are properly aligned with glass.
- Install temporary pressure plates 18" on center both horizontally and vertically.

See **Details 45 & 46**.

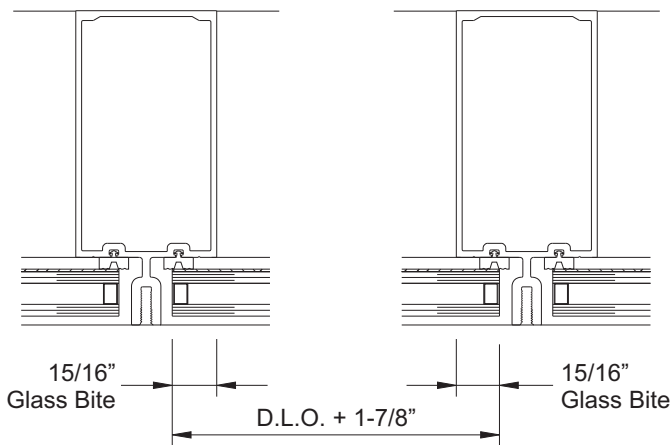
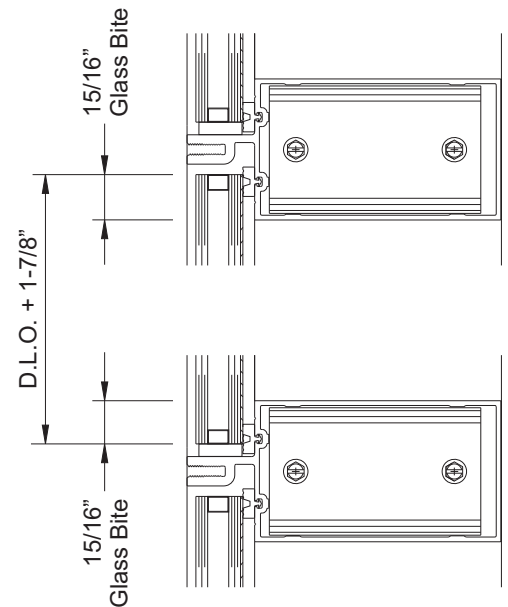

DETAIL 45
Insulating Glazing Shown
Single Glazing Similar

**GLASS SIZE = D.L.O. + 1-7/8"
(HORIZONTAL & VERTICAL)**

GLAZING

STEP 24 INSTALL PRESSURE PLATES

- Cut exterior vertical gaskets to the same length as the vertical pressure plates.
- Cut exterior horizontal gaskets to daylight opening plus(+) 1/4" for shrinkage.
- Install by pushing the exterior gaskets into the reglets of the pressure plates.

Note: See Glazing Table below for proper gasket usage.

- Apply silicone sealant to face of joint plug just prior to installing vertical pressure plate. Sealant must form a complete seal between the exterior gasket, the pressure plate, the thermal isolator, and the joint plugs.

See **Detail 46**.

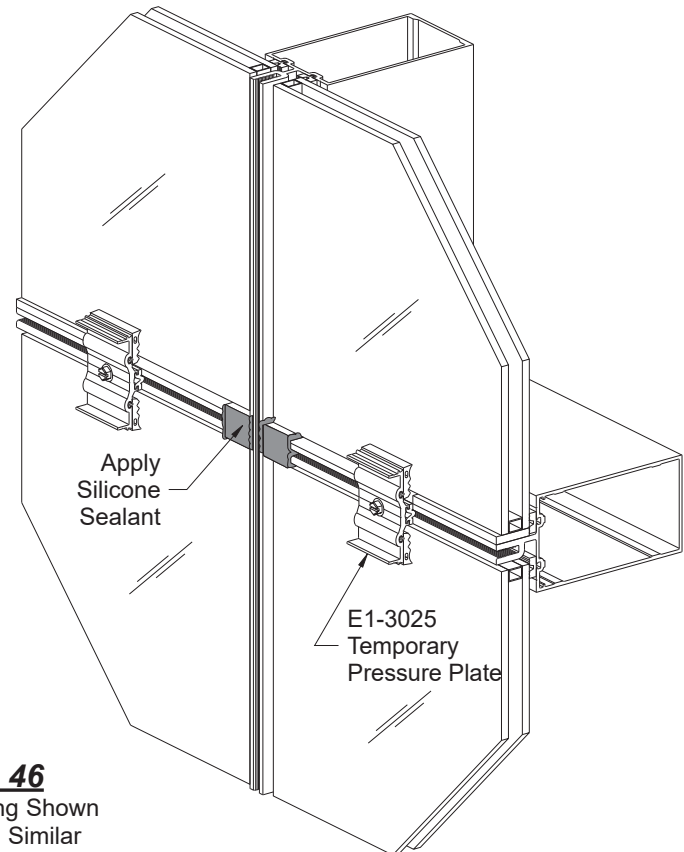

DETAIL 46
Insulating Glazing Shown
Single Glazing Similar

YHC 300 OG GLAZING TABLE

	Glass Size	Exterior Gasket	Dry Glazed Interior Gasket	Wet Glazed Interior Spacer	Glazing Adaptor	Pressure Plate	Perimeter P. Plate
Single	1/4"	E2-0380	E2-0380	E2-0353*	—	AS-3173	AS-3179
	9/16"	E2-0379	E2-0379	E2-0353*	—	AS-3173	AS-3179
Insulating	9/16"	E2-0379	E2-0379	E2-0353*	E9-3141	AS-3172	AS-3178
	1" (Dry)	E2-0380	E2-0380	—	—	AS-3172	AS-3178
	1" (Wet)	E2-0380	—	E2-0353*	—	AS-3173	AS-3173 w/ E9-8215 & E2-0239
	1-5/16"	E2-0379	E2-0379	E2-0353*	—	AS-3172	AS-3178

* Interior Spacer E2-0222 will be used for design pressures above 90 PSF.

GLAZING

STEP 24 (Continued)
INSTALL PRESSURE PLATES

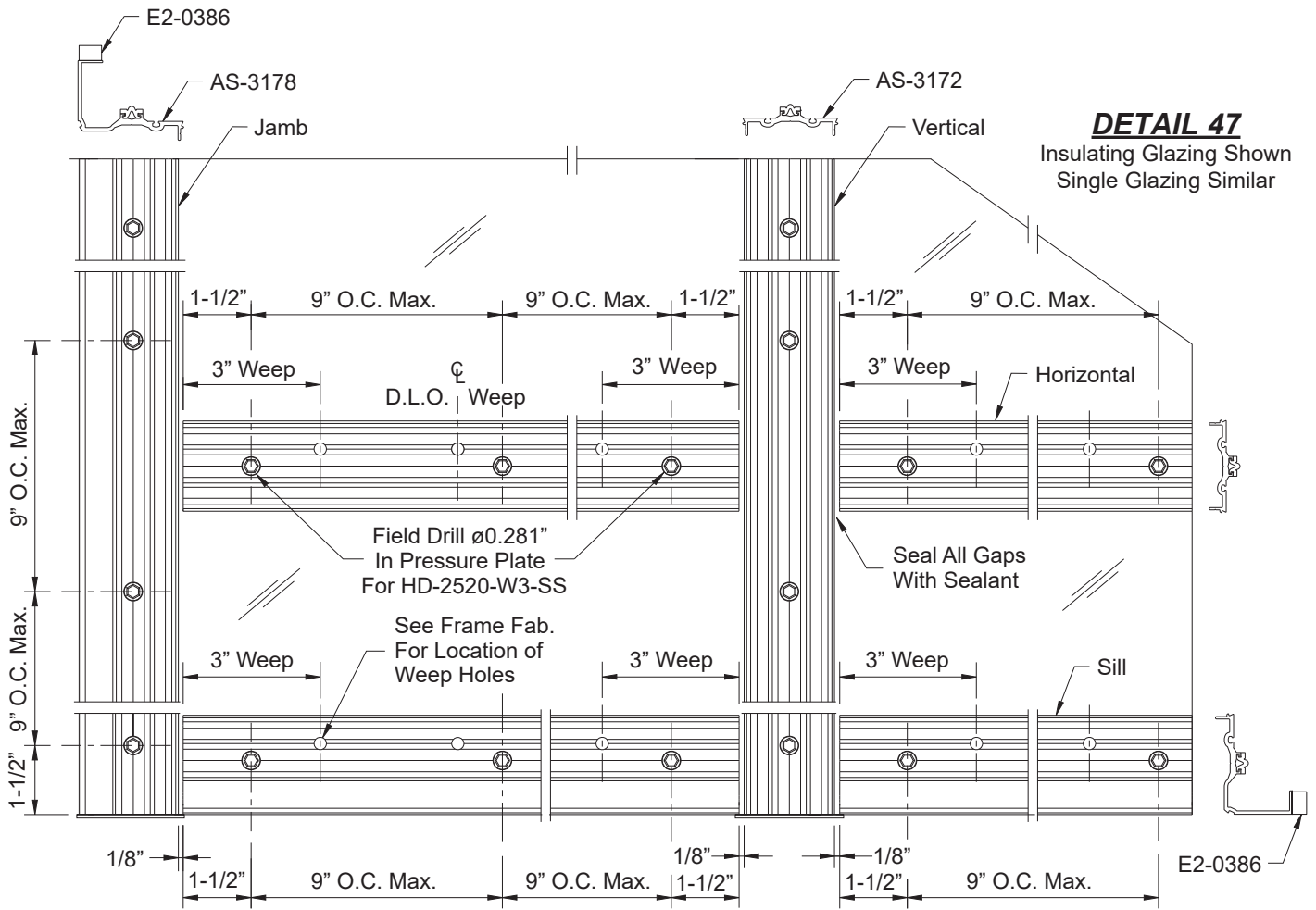

DETAIL 47
Insulating Glazing Shown
Single Glazing Similar

- Apply isolator tape, E2-0386, to the inside leg of all perimeter pressure plates.
- Install vertical pressure plates first: Fasten with HD-2520-W3-SS fasteners.
- Initially torque fasteners to 50 inch-pounds with a speed wrench or torque limiting screw gun. Work from the bottom up.
- Torque all fasteners to 75 inch-pounds.

See **Detail 47**.

GLAZING

**STEP 25
INSTALL EXTERIOR FACE COVERS**

- Snap on vertical exterior face covers using a mallet and a clean scrap piece of lumber, starting at the top and working down the vertical.
- Center and install horizontal pressure plates in the opening with HD-2520-W3-SS fasteners, leaving a 1/8" gap at the ends. Initially torque the fasteners to 50 inch-pounds; then tighten all of them to 75 inch-pounds.
- Apply and tool sealant to completely seal the gaps at horizontal pressure plate ends.
- Snap on horizontal face covers, starting at one end and working block and mallet across the horizontal.

See **Detail 48**.

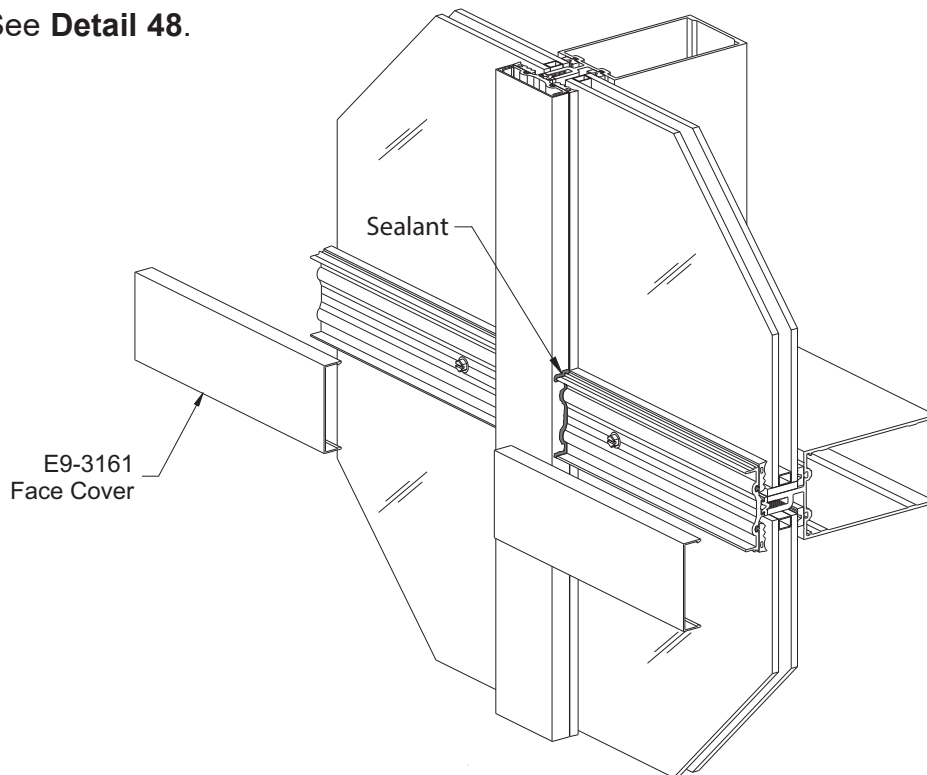

DETAIL 48
Insulating Glazing Shown
Single Glazing Similar

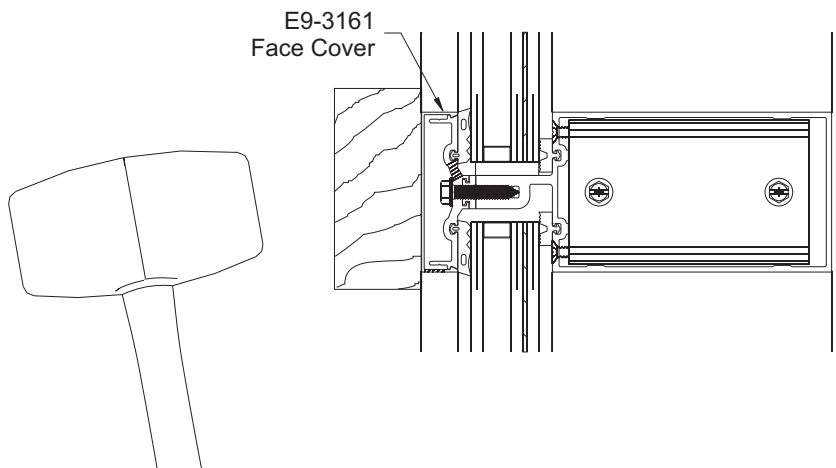

GLAZING

**STEP 26
APPLY INTERIOR SILICONE SEALANT**

- Make sure all silicone contact surfaces and joints have been cleaned with a cleaner and method as approved by sealant manufacturer.
- Apply masking tape to the mullion and glass as shown in **Detail 49**.
- Apply tested structural silicone sealant into the cavity between the mullion and glass starting from the bottom and work towards the top. Use positive pressure so that the silicone sealant completely fills the cavity.
- Using a nylon spatula or other non-scratching implement, tool the silicone sealant immediately after running the joint. Exert positive pressure while tooling to ensure that the silicone sealant makes complete contact with all surfaces.

Caution: Be careful not to remove too much silicone sealant.

- Remove masking tape immediately after tooling and before silicone skins over.

Caution: Do not permit the silicone sealant to skin over before it is tooled. Immediately remove masking tape after tooling silicone sealant.

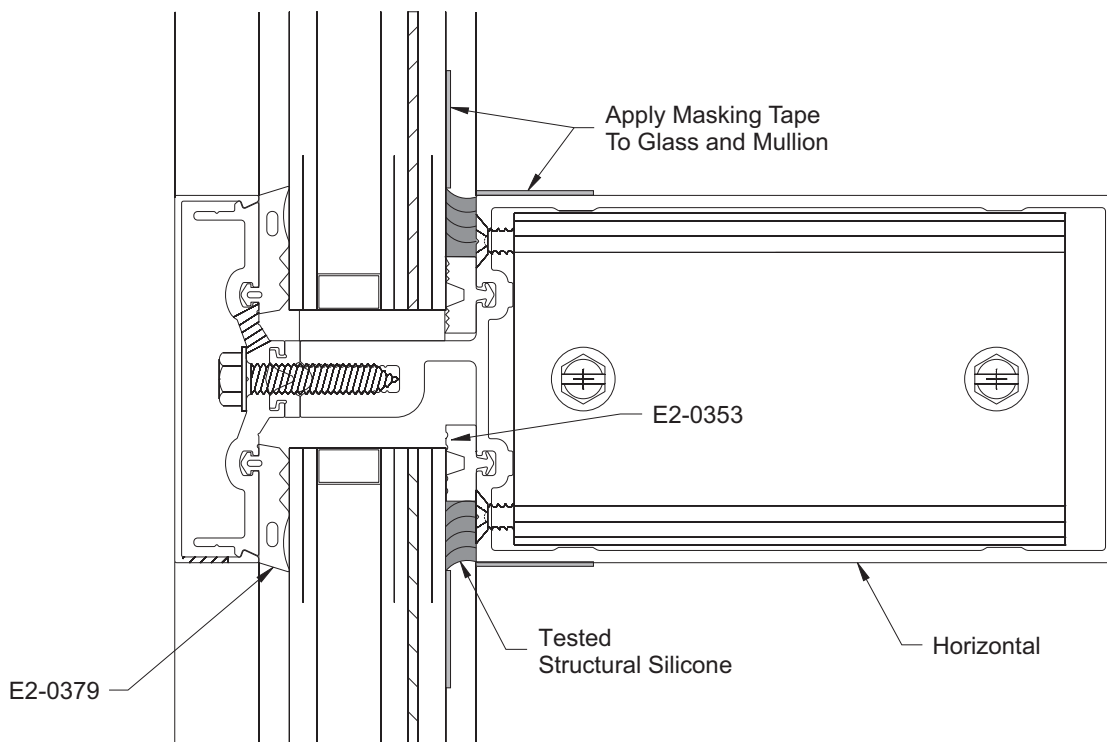

DETAIL 49
Insulating Glazing Shown
Single Glazing Similar



101 Marietta Street NW
Suite 2100
Atlanta, Georgia 30303
www.ykkap.com