

YCW 750 OG Outside Glazed Curtain Wall System

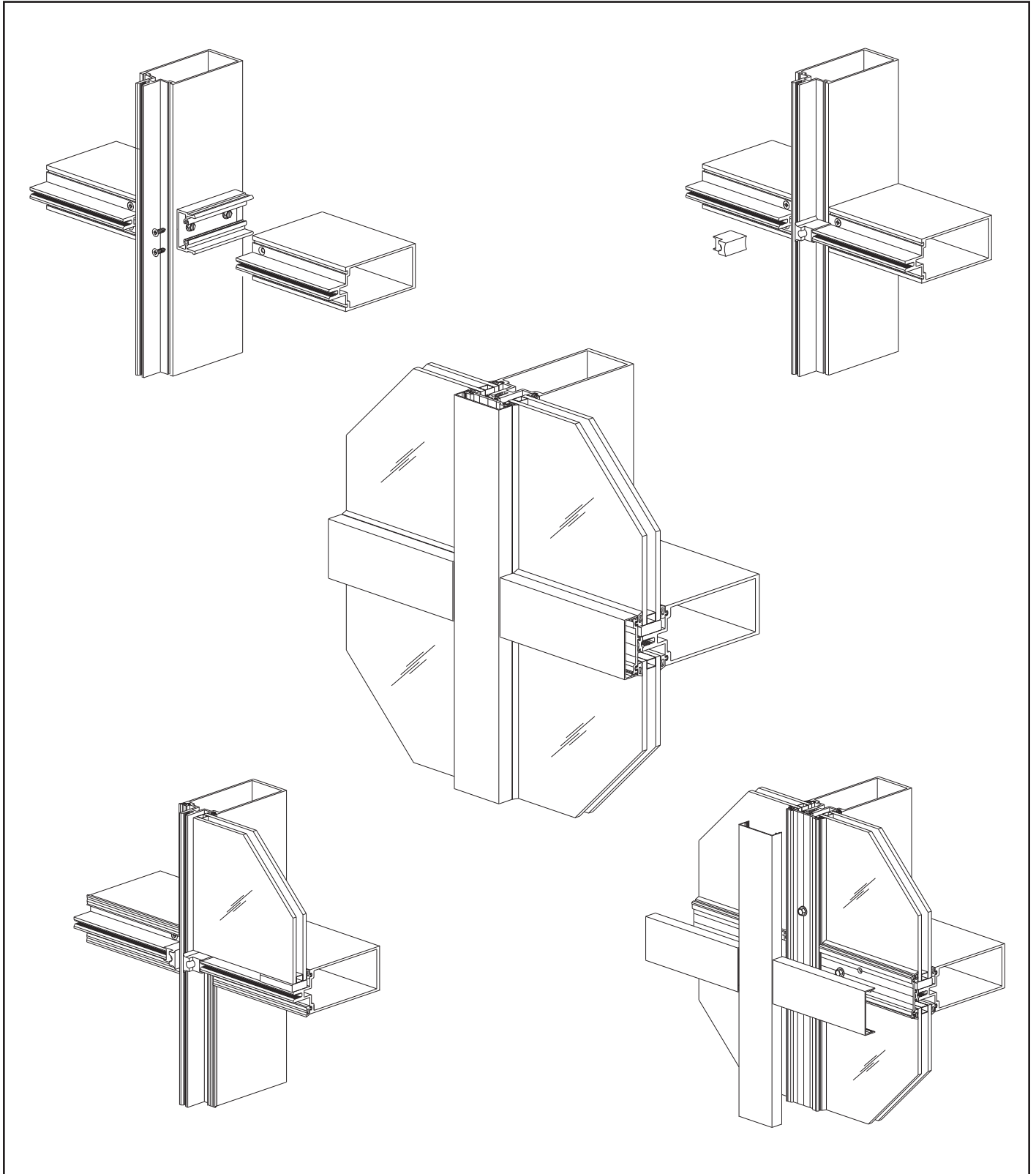

Installation Manual

TABLE OF CONTENTS

Installation Notes Page ii

PARTS DESCRIPTION

YCW 750 OG Framing Members Pages 1 to 3

YCW 750 OG Accessories Pages 3 to 6

FRAME FABRICATION

Anchoring Methods/Framing Types..... Pages 7 & 8

Fabricate Vertical Mullions Pages 9 to 11

Using Steel Reinforcing Page 12

Assemble 90° Outside Corner Mullions..... Page 13

Attach Shear Blocks/Clips for Horizontals..... Pages 14 & 15

Attach “J” Anchors Page 16

Fabricate Horizontal Members Pages 17 to 22

Fabricate Pressure Plates Page 23

Fabricate Face Covers Page 24

FRAME INSTALLATION

Typical Vertical Splice Pages 25 & 26

Install Continuous Perimeter Anchor..... Page 27

Jamb/Vertical Installation with Perimeter Anchors Page 29

Jamb Installation with Jamb Anchors Page 29

Jamb/Vertical Installation with Mullion End Anchors..... Pages 30 & 31

Install Wind Load/Dead Load Anchors Pages 32 to 34

Attach Horizontal Members Pages 35 to 40

Install Door Subframes Page 41

Apply Perimeter Sealant..... Pages 42 & 43

Install Joint Plugs..... Page 44

GLAZING

Install Glazing Adaptors..... Page 45

Install Interior Glazing Gaskets Page 46

Install Setting & Side Blocks Page 47

Install Exterior Glazing Gaskets Page 48

Install Glass Page 48

Pressure Plate Layout and Assembly Page 49

Install Exterior Face Covers Page 50

Install Optional Deep Face Covers..... Page 51

Installation Notes

















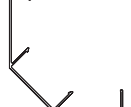





1. Do not drop, roll or drag boxes of aluminum framing. Move and stack boxes with proper support to prevent distortion. If fork lifts are used, be especially careful about striking the boxes when lifting or moving.
2. Store in a dry, out of the way area. If rain exposure, condensation or any water contact is likely, then all packaging material should be removed. Wet packaging materials will discolor and may stain aluminum finishes and paints.
3. All materials should be checked for quality and quantity upon receipt, YKK AP must be notified immediately of any discrepancies in shipment. Check to make sure that you have the required shims, sealants, supplies and tools necessary for the installation.
4. Carefully check the openings and surrounding conditions that will receive your material. Remember, if the construction is not per the construction documents, it is your responsibility to notify the general contractor in writing. Any discrepancies must be brought to the general contractor's attention before you proceed with the installation.
5. These installation instructions are of a general nature and may not cover every condition you will encounter. The shop drawings prepared should be specifically for the project.
6. Any material substitutions must be of equal or greater quality.
7. Make certain that material samples have been sent for compatibility and adhesion testing for all manufacturer's sealants involved. Make certain sealants have been installed in strict accordance with the sealant manufacturer's recommendations and specifications.
8. Remember to isolate, in an approved manner, all aluminum from uncured masonry or other incompatible materials.
9. System-to-structure fasteners are not supplied by YKK AP. Fasteners called out on shop drawings are to indicate minimum sizes for design loading.
10. If any questions arise concerning YKK AP products or their installation, contact YKK AP for clarification before proceeding.
11. YKK AP storefront and/or curtain wall framing is typically completed before drywall, flooring and other products which may still be in process. Wrap and protect the material when stored at job site.
12. Cutting tolerances are plus zero, minus one thirty second unless otherwise noted.
13. Check our website, www.ykkap.com, for the latest installation manual update prior to commencing work.

FRAMING MEMBERS

	Vertical / Horizontal 2-1/2" x 5-1/4" For 1/4" Glazing	E9-1246		Vertical / Horizontal 2-1/2" x 3-3/4" For 1" Glazing	E9-1235
	Vertical / Horizontal 2-1/2" x 3-3/4" For 1/4" Glazing	E9-1250		Vertical / Horizontal Heavy Duty 2-1/2" x 3-3/4" For 1" Glazing	E9-3537
	Jamb Open Back 2-1/2" x 5-1/4" For 1/4" Glazing	E9-3588		Vertical / Horizontal 2-1/2" x 6-3/4" For 1" Glazing	E9-1242
	Jamb Open Back 2-1/2" x 3-3/4" For 1/4" Glazing	E9-3592		Jamb Open Back 2-1/2" x 5-1/4" For 1" Glazing	E9-3580
	Head / Sill Open Back 2-1/2" x 5-1/4" For 1/4" Glazing	E9-3587		Jamb Open Back 2-1/2" x 3-3/4" For 1" Glazing	E9-3584
	Head / Sill Open Back 2-1/2" x 3-3/4" For 1/4" Glazing	E9-3591		Head / Sill Open Back 2-1/2" x 5-1/4" For 1" Glazing	E9-3579
	Optional Head For Incidental Water 2-1/2" x 5-1/4" For 1/4" Glazing	E9-3590		Head / Sill Open Back 2-1/2" x 3-3/4" For 1" Glazing	E9-3583
	Optional Head For Incidental Water 2-1/2" x 3-3/4" For 1/4" Glazing	E9-3594		Optional Head For Incidental Water 2-1/2" x 5-1/4" For 1" Glazing	E9-3582
	Horizontal Open Back 2-1/2" x 5-1/4" For 1/4" Glazing	E9-3589		Optional Head For Incidental Water 2-1/2" x 3-3/4" For 1" Glazing	E9-3586
	Horizontal Open Back 2-1/2" x 3-3/4" For 1/4" Glazing	E9-3593		Horizontal Open Back 2-1/2" x 5-1/4" For 1" Glazing	E9-3581
	Vertical / Horizontal 2-1/2" x 5-1/4" For 1" Glazing	E9-1215		Horizontal Open Back 2-1/2" x 3-3/4" For 1" Glazing	E9-3585
	Vertical / Horizontal 2-1/2" x 5-1/4" For 1" Glazing	E9-1225		Horizontal Flush Filler For 5-1/4" Depth Open Back Members	E9-3162

* Splay mullions and other face covers are available, contact YKK AP.

FRAMING MEMBERS

	Horizontal Flush Filler For 3-3/4" Depth Open Back Members	E9-3595		Horizontal Face Cover 11/16" x 2-1/2"	E9-1207
	Pressure Plate With PVC Isolator For 1/4" & 1" Glazing	AS-1216		Bull Nose Face Cover 2-1/2" x 2"	E9-1293
	Perimeter Pressure Plate With PVC Isolator For 1/4" Glazing	AS-3572		90° Outside Corner Face Cover For 1/4" Glazing	E9-1238
	Perimeter Pressure Plate With PVC Isolator For 1" Glazing	AS-3569		90° Outside Corner Face Cover For 1" Glazing	E9-1228
	Pressure Plate For Deep Covers With PVC Isolator For 1/4" & 1" Glazing	AS-3574		Interior Cover Base Use with E9-1281	E9-1280
	Perimeter Pressure Plate For Deep Covers With PVC Isolator For 1" Glazing	AS-3576		Interior Cover For 5-1/4" Back Depth 90° Outside Corner Use with E9-1280	E9-1281
	90° Outside Corner Adaptor For 1/4" Glazing	E9-1236		Interior Cover For 6-3/4" Back Depth 90° Outside Corner Use with E9-1280	E9-3548
	90° Outside Corner Pressure Plate With PVC Isolator For 1/4" Glazing	AS-1237		Glazing Adaptor For 1/4" glazing	E9-1220
	90° Outside Corner Adaptor For 1" Glazing	E9-1226		Glazing Adaptor For 1/2" Glazing	E9-1232
	90° Outside Corner Pressure Plate With PVC Isolator For 1" Glazing	AS-1227		Flush Pocket Filler For 1" glazing	E9-1253
	Face Cover 2-1/2 x 3/4"	E9-1206		Perimeter Anchor For 1/4" Glazing	E9-1248
	Face Cover 2-1/2" x 2-3/8" Use with AS-3574 & AS-3576	E9-1219		Perimeter Anchor For 1" Glazing	E9-1223

* Splay Mullions and other face covers are available, contact YKK AP.











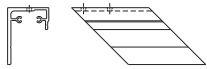

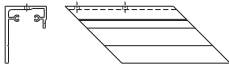

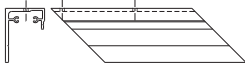

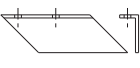

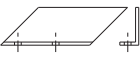

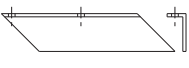



FRAMING MEMBERS

	Perimeter Channel For 1" Glazing	E9-1231		Snap-In Door Stop For 20D/35D/50D Doors E2-0051 Gasket Included Use with E9-1224 & E9-3513	AS-0417
	Single Acting Transom Bar For 20D/35D/50D Doors E2-0051 Gasket Included	AS-0402		Heavy Duty Transom Bar For 40M/50M Doors E2-0051 Included	AS-0467
	Standard Door Jamb For 20D/35D/50D Doors & 1/4" Glazing Use with AS-0417	E9-1224		Heavy Duty Door Jamb For 40M/50M Doors Use with AS-0458	E9-3617
	Standard Door Jamb For 20D/35D/50D Doors & 1" Glazing Use with AS-0417	E9-3513		Snap-In Door Stop For 40M/50M Doors E2-0051 Gasket Included Use with E9-3617	AS-0458











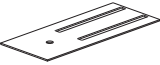
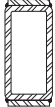
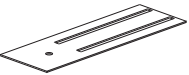

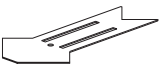
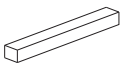
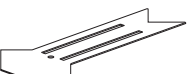
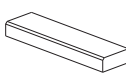

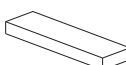

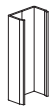

ACCESSORIES

	Standard Shear Block For 3-3/4" Back Depth 3.125" Long	E1-3503		Optional Shear Clip For 5-1/4" Back Depth Incidental Water Head	E1-3019
	Standard Shear Block For 5-1/4" Back Depth 4.375" Long	E1-3504		Shear Block (For E-Slot) For 3-3/4" Back Depth 3.125" Long	E1-1206
	Standard Shear Block For 6-3/4" Back Depth 6.000" Long	E1-3506		Shear Block (For E-Slot) For 5-1/4" Back Depth 4.375" Long	E1-1200
	"J" Anchor For 3-3/4" Back Depth 3.125" Long	E1-3501		Shear Block (For E-Slot) For 6-3/4" Back Depth 6.000" Long	E1-1236
	"J" Anchor For 5-1/4" Back Depth 4.375" Long	E1-3502		Shear Block for 90° Outside Corner For 3-3/4" Back Depth 5.794" Long	E1-3503A
	"J" Anchor For 6-3/4" Back Depth 6.000" Long	E1-3505		Shear Block for 90° Outside Corner For 5-1/4" Back Depth 7.562" Long	E1-3504A
	Optional Shear Clip For 3-3/4" Back Depth Incidental Water Head	E1-3523		Shear Block for 90° Outside Corner For 6-3/4" Back Depth 9.860" Long	E1-3506A

ACCESSORIES

	<p>“J” Anchor for 90° Outside Corner For 3-3/4” Back Depth 5.669” Long</p>	<p>E1-3501A E1-3501B</p>		<p>Mullion “T” Anchor For E9-1235, E9-1250, & E9-3537, 3.462” Long</p>	<p>E1-1207</p>
	<p>“J” Anchor for 90° Outside Corner For 5-1/4” Back Depth 7.437” Long</p>	<p>E1-3502A E1-3502B</p>		<p>Mullion “T” Anchor For E9-1215 Only 4.866” Long</p>	<p>E1-1208</p>
	<p>“J” Anchor for 90° Outside Corner For 6-3/4” Back Depth 9.375” Long</p>	<p>E1-3505A E1-3505B</p>		<p>Mullion “T” Anchor For E9-1225 & E9-1246 4.960” Long</p>	<p>E1-1209</p>
	<p>Shear Clip for 90° Outside Corner (RH) For 3-3/4” Depth Optional Incidental Water Head</p>	<p>E1-3534</p>		<p>Mullion “T” Anchor For E9-1242 6.453” Long</p>	<p>E1-1238</p>
	<p>Shear Clip for 90° Outside Corner (LH) For 3-3/4” Depth Optional Incidental Water Head</p>	<p>E1-3535</p>		<p>Mullion “F” Anchor For E9-1235, E9-1250, E9-3537, E9-3584 & E9-3592, 3.462” Long</p>	<p>E1-1232</p>
	<p>Shear Clip for 90° Outside Corner (RH) For 5-1/4” Depth Optional Incidental Water Head</p>	<p>E1-3532</p>		<p>Mullion “F” Anchor For E9-1215 4.866” Long</p>	<p>E1-1233</p>
	<p>Shear Clip for 90° Outside Corner (LH) For 5-1/4” Depth Optional Incidental Water Head</p>	<p>E1-3533</p>		<p>Mullion “F” Anchor For E9-1225, E9-1246, E9-3580 & E9-3588 4.960” Long</p>	<p>E1-1231</p>
	<p>Mullion Splice Sleeve For 3-3/4” Back Depth</p>	<p>E1-1212</p>		<p>Mullion “F” Anchor For E9-1242 6.453” Long</p>	<p>E1-1240</p>
	<p>Mullion Splice Sleeve For 5-1/4” Back Depth</p>	<p>E1-1201</p>		<p>Temporary Glass Retainer 2” Long</p>	<p>E1-1294</p>
	<p>Mullion Splice Sleeve For 6-3/4” Back Depth</p>	<p>E1-1299</p>		<p>Mullion End Cap 2.500” x 2.313” x 0.050”</p>	<p>E1-1286</p>
	<p>Mullion Splice Sleeve For 3-3/4” Back Depth Open Back Jamb</p>	<p>E1-1354</p>		<p>Mullion End Cap for 90° Outside Corner For 1/4” Glazing</p>	<p>E1-3519</p>
	<p>Face Cover Splice Sleeve For E9-1206</p>	<p>E1-1202</p>		<p>Mullion End Cap for 90° Outside Corner For 1” Glazing</p>	<p>E1-3520</p>













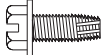





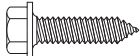

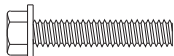

ACCESSORIES

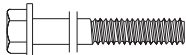
	Mullion End Cap For 3-3/4" Depth Optional Incidental Water Head	E1-3527		Steel Reinforcement 2" x 4" x 1/4" Steel Tube & (2) 1/4" x 1-3/4" Steel Bars With Zinc Oxide Paint	E1-0154
	Mullion End Cap For 5-1/4" Depth Optional Incidental Water Head	E1-3526		Setting Block For 1/4" Glazing EPDM with Pressure Sensitive Adhesive	E2-0112
	90° O.C. Mullion End Cap For 1/4" Glazing 3-3/4" Depth Optional Incidental Water Head	E1-3531		Side Block For 1/4" Glazing EPDM with Pressure Sensitive Adhesive	E2-0113
	90° O.C. Mullion End Cap For 1/4" Glazing 5-1/4" Depth Optional Incidental Water Head	E1-3530		Setting Block For 1" Glazing EPDM	E2-0104
	90° O.C. Mullion End Cap For 1" Glazing 3-3/4" Depth Optional Incidental Water Head	E1-3529		Side Block For 1" Glazing EPDM	E2-0105
	90° O.C. Mullion End Cap For 1" Glazing 5-1/4" Depth Optional Incidental Water Head	E1-3528		Standard Joint Plug For 1/4" Glazing EPDM Sponge	E2-0125
	Optional Jamb Anchor Clip For Open Back Jambs E9-3584 & E9-3592	E1-3524		Standard Joint Plug For 1" Glazing EPDM Sponge	E2-0102
	Optional Jamb Anchor Clip For Open Back Jambs E9-3580 & E9-3588	E1-3525		Joint Plug For Slide-In Horizontal at End Bays, 1/4" Glazing Use with E2-0123	E2-0129
	Wind Load Anchor Steel with Zinc Oxide Paint Refer to Shop Drawings for Anchor Dimensions	E1-1204* Project Specific		Joint Plug For Slide-In Horizontal at End Bays, 1" Glazing Use with E2-0123	E2-0124
	Dead Load Anchor Steel with Zinc Oxide Paint Refer to Shop Drawings for Anchor Dimensions	E1-1205* Project Specific		End Dam Plug Use with E9-1223 & E9-1231	E2-0505
	Jamb Anchor Plate	E1-3536		E-Slot Plug For Slide-In Horizontal at End Bays	E2-0123
	Steel Reinforcement 2" x 4" x 1/4" Steel Tube With Zinc Oxide Paint	E1-0162		Isolator Tape 1/8" x 7/16" Use with Perimeter Pressure Plate	E2-0239

* Note: Project specific part number.

Exact size of anchors should be determined from loads calculated on each individual curtain wall frame.

ACCESSORIES

	Interior/Exterior Glazing Gasket	E2-0120		#14 x 5/8" FHSMS Type AB, Zinc Plated Steel For Attachment of Mullion End Caps	FC-1410
	Weep Baffle For Optional Incidental Water Head Members	E2-0099		1/4"-20 x 5/8" HWHS Type F, Zinc Plated Steel For Attachment of Std. Shear Block to Vertical	HF-2510 -W1
	Anchor Slip Pad For Dead Load & Wind Load Anchors	E3-0103		1/4"-20 x 1" HWHS Type F, Zinc Plated Steel, For Attach. of Std. Shear Block to Vertical with Steel Reinforcing	HF-2516 -W1
	Drill Fixture	H-7210		1/4"-20 x 1-3/4" HWHS Type F, Zinc Plated Steel For Attachment of Opt. Shear Clip to Vertical	HF-2528 -W1
	#8 x 3/8" PHSMS Zinc Plated Steel For Attachment of Glazing Adaptors	PC-0806		1/4"-20 x 1" HWHMS Type CA, Stainless Steel For Attachment of Pressure Plate to Mullion	HD-2516 -W3-SS
	#8 x 1/2" FHSMS Type AB Stainless Steel For Attachment of Deep Face Cover at Exposed Area	FC-0808 -SS		1/4"-20 x 1" HWHMS Zinc Plated Steel For Attachment of "J" Anchor at Jamb	HM-2516 -W3
	#8 x 1/2" PHSMS Type AB Stainless Steel, For Attachment of Deep Face Cover at Concealed Area	PC-0808 -SS		1/4"-20 x 1-1/4" HWHMS Zinc Pl. Stl., For Attachment of 90° O.S. Corner Adaptor E9-1236 to Vert. (1/4" Glazing)	HM-2520 -W3
	#8 x 1/2" PHSMS Type F Stainless Steel For Attachment of Face Cover Splice Sleeves	PF-0808 -SS		1/4"-20 x 3-1/2" HWHMS Zinc Plated Steel, For Attachment of "J" Anchor at Intermediate Vertical	HM-2556 -W3
	#10 x 5/8" PHSMS Type AB, Zinc Plated Steel For Attachment of Interior Cover Base	PC-1010		1/4"-20 Nut HHMS Zinc Plated Steel, For Attachment of "J" Anchor at Intermediate Vertical & Jamb	HM-2500
	#12 x 1/2" PHSMS Type AB, Zinc Plated Steel For Attachment of Optional Head to Shear Clips	FC-1208		1/4" Flat Washer Zinc Plated Steel, For Attachment of "J" Anchor at Intermediate Vertical & Jamb	WW-2500
	#12 x 3/4" FHSMS Type AB, Zinc Plated Steel (Exposed Fasteners), For Attachment of Horizontal to Shear Block	FC-1212		1/4" Lock Washer Zinc Plated Steel, For Attachment of "J" Anchor at Intermediate Vertical & Jamb	WS-2500
	#12 x 1-1/4" FHSMS Type AB Zinc Plated Steel (Concealed Fasten.) For Attachment of Horizontal to Shear Block	FC-1220			

FRAME FABRICATION

FRAME TYPES / ANCHORING METHODS

The following is a guideline for common types of frames. Refer to shop drawings for exact layout of frames.

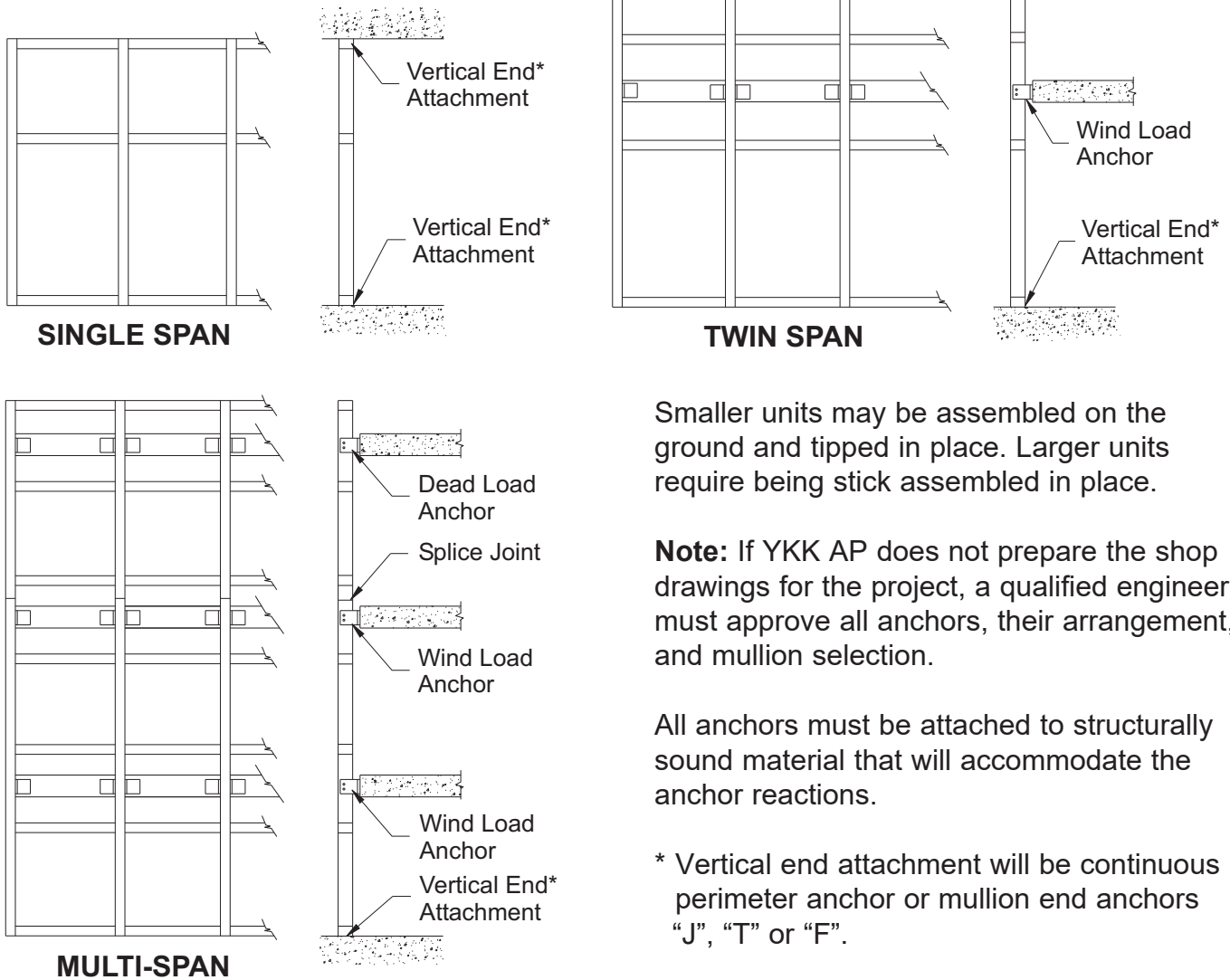

Smaller units may be assembled on the ground and tipped in place. Larger units require being stick assembled in place.

Note: If YKK AP does not prepare the shop drawings for the project, a qualified engineer must approve all anchors, their arrangement, and mullion selection.

All anchors must be attached to structurally sound material that will accommodate the anchor reactions.

* Vertical end attachment will be continuous perimeter anchor or mullion end anchors “J”, “T” or “F”.

Fabrication of YCW 750 OG varies depending on the type of vertical end attachment required for a given project:

Perimeter Anchors are for low load anchoring conditions (maximum 500lb. end load reaction):
E9-1248, E9-1223, & E9-1231

“J” Anchors are for medium to high load conditions: E1-3501, E1-3502, & E1-3505.

“T” & “F” Anchors are for high load conditions: E1-1207, E1-1208, E1-1209, E1-1231, E1-1232, E1-1233, E1-1238, & E1-1240

FRAME FABRICATION

FRAME TYPES / ANCHORING METHODS

Using Perimeter Anchors:

-Vertical mullions must be notched as shown in **Detail 1** on **Page-9**.

Using Mullion End Anchors:

YCW 750 OG has four possible end anchoring conditions: "J", "T", "F", and Door Jamb.

- "J" anchors are used with jambs and intermediate verticals at the sill only.
- "T" anchors are used with intermediate verticals at the head and sill.
- "F" anchors are used with jamb mullions at the head and sill.
- "Door Jamb" anchors are used with mullions at a door jamb and are specified by the approved shop drawings or P.E. calcs.
- Anchor usage depends on end reaction, stress, and attachment.

Mullions should be pre-assembled with shear blocks/clips, end anchors, and steel or aluminum reinforcing if necessary.

End anchors should be pre-drilled for anchor fasteners according to approved shop drawings or engineering calculations.

Framing Members for Stick Build:

- Open back head and sill members provide easy access to end anchor bolts.
- Closed horizontal members are used at all intermediate locations except at end bays.
- Open back intermediate horizontals are used at end bays to clear the shear blocks.

Note: When using stick build construction, check overall frame width every fifth mullion as the wall is installed. A buildup of cumulative tolerance errors may occur, resulting in excessive DLO spacing.

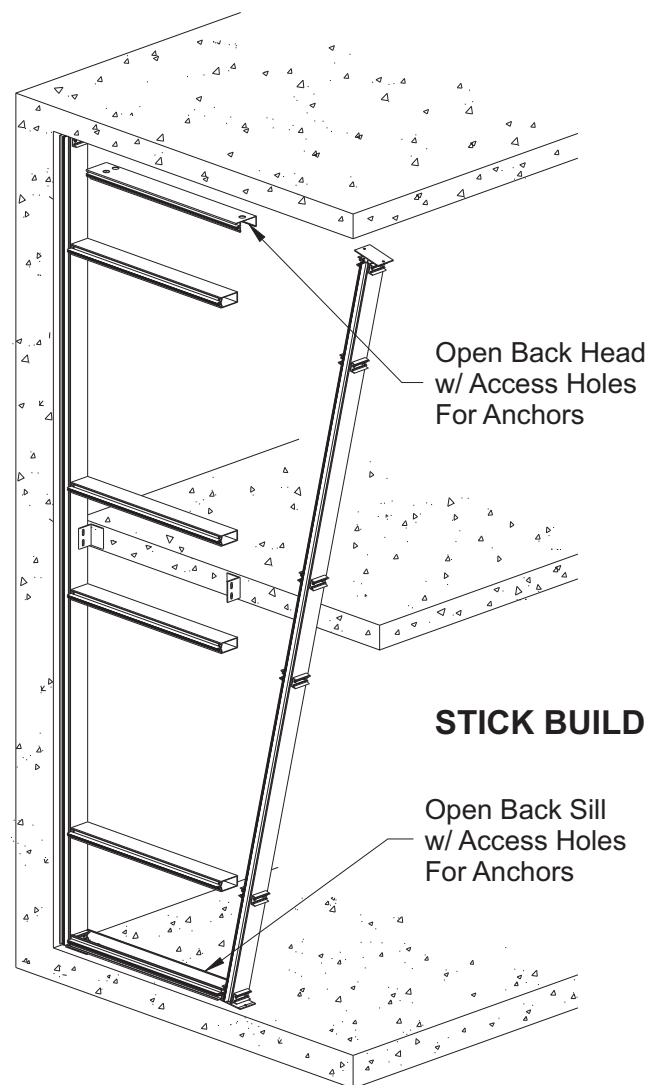

FRAME FABRICATION

FABRICATE VERTICAL MULLIONS

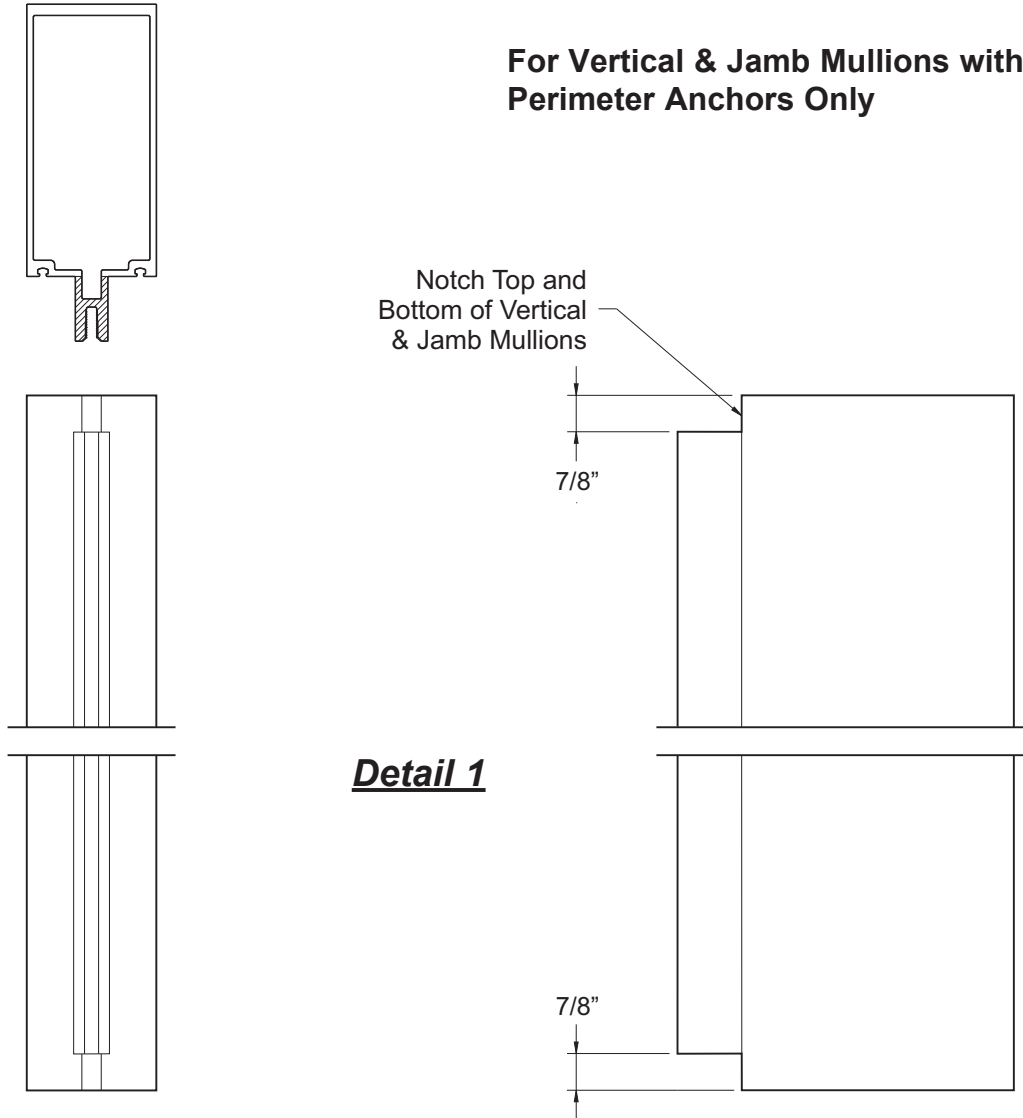

Step 1

-Cut all vertical and jamb mullions to dimensions as shown on shop drawings.

Allow for 1/2" caulk joint around the frame & 1/2" joint at vertical splices.

Note: Mullions at door jambs are sealed against the substrate at the sill without a shim space at that location.

Step 2

-When using continuous perimeter anchors, E9-1223, E9-1231 or E9-1248, the top and bottom of vertical and jamb mullions must be notched as shown in **Detail 1**, and sealed as shown on **Page 28**.

Note: Do not notch verticals when using mullion end anchors: "J", "T" or "F".

FRAME FABRICATION

STEP 3
FABRICATE VERTICAL MULLIONS

- Mullion hole locations for shear blocks, shear clips, and "J" anchors are shown below.
 - Drill 0.213" dia. (#3 bit) holes for shear block/clip attachment at the locations indicated.
 - Drill 0.281" dia. (#9/32 bit) holes for "J" anchor attachment at the sill at the locations indicated.
- See **Detail 2**.

Note: Hole locations for standard shear blocks are not the same as shear clips for optional incidental water head.

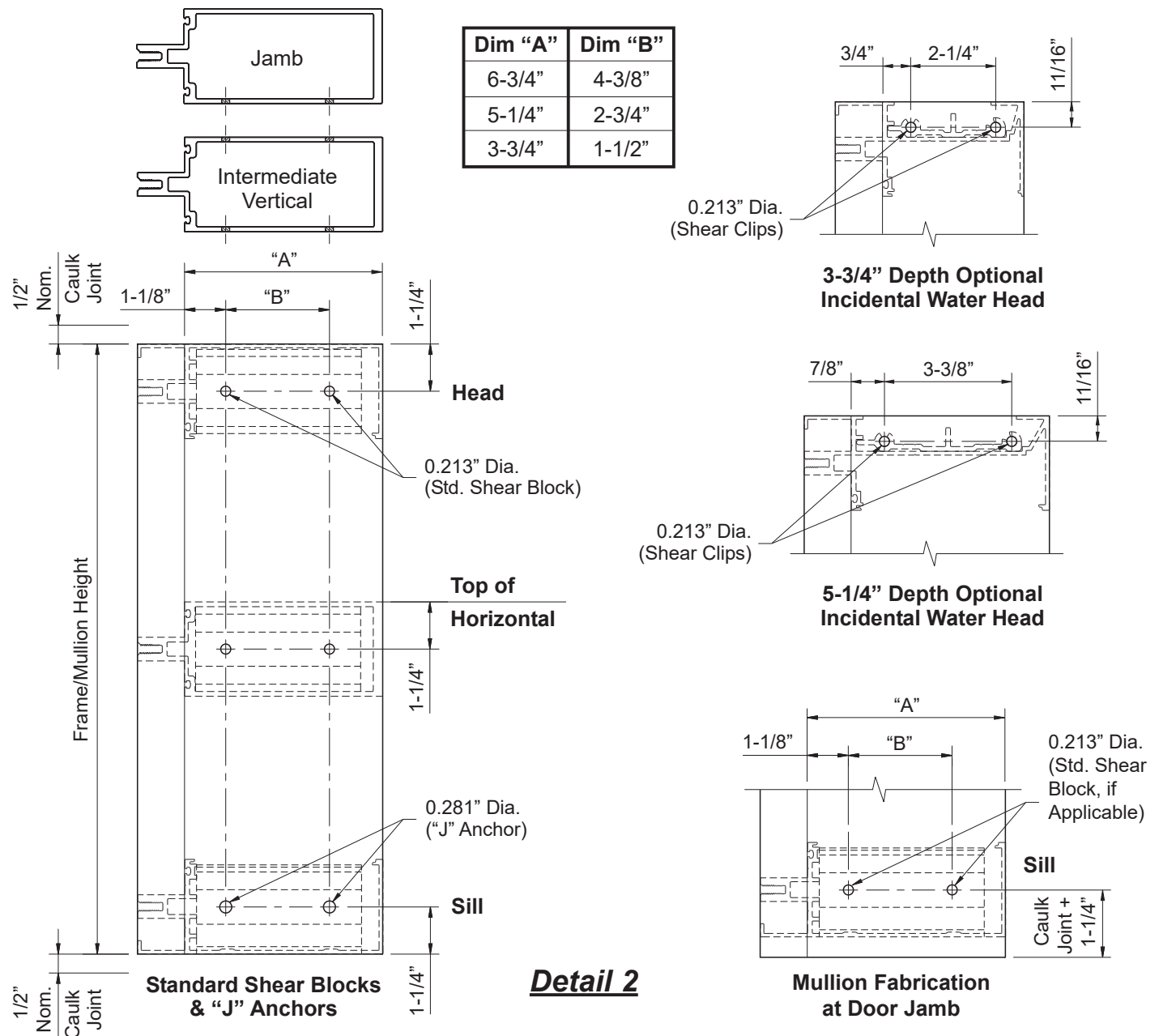

FRAME FABRICATION

STEP 3 (Continued)

FABRICATE 90° OUTSIDE CORNER MULLIONS

- Mullion hole locations for shear blocks, shear clips, and “J” anchors are shown below.
 - Drill 0.213” dia. (#3 bit) holes for shear block/clip attachment at the locations indicated.
 - Drill 0.281” dia. (#9/32 bit) holes for “J” anchor attachment at the sill at the locations indicated.
- See **Detail 3**.

Note: Hole locations for standard shear blocks are not the same as shear clips for optional incidental water head.

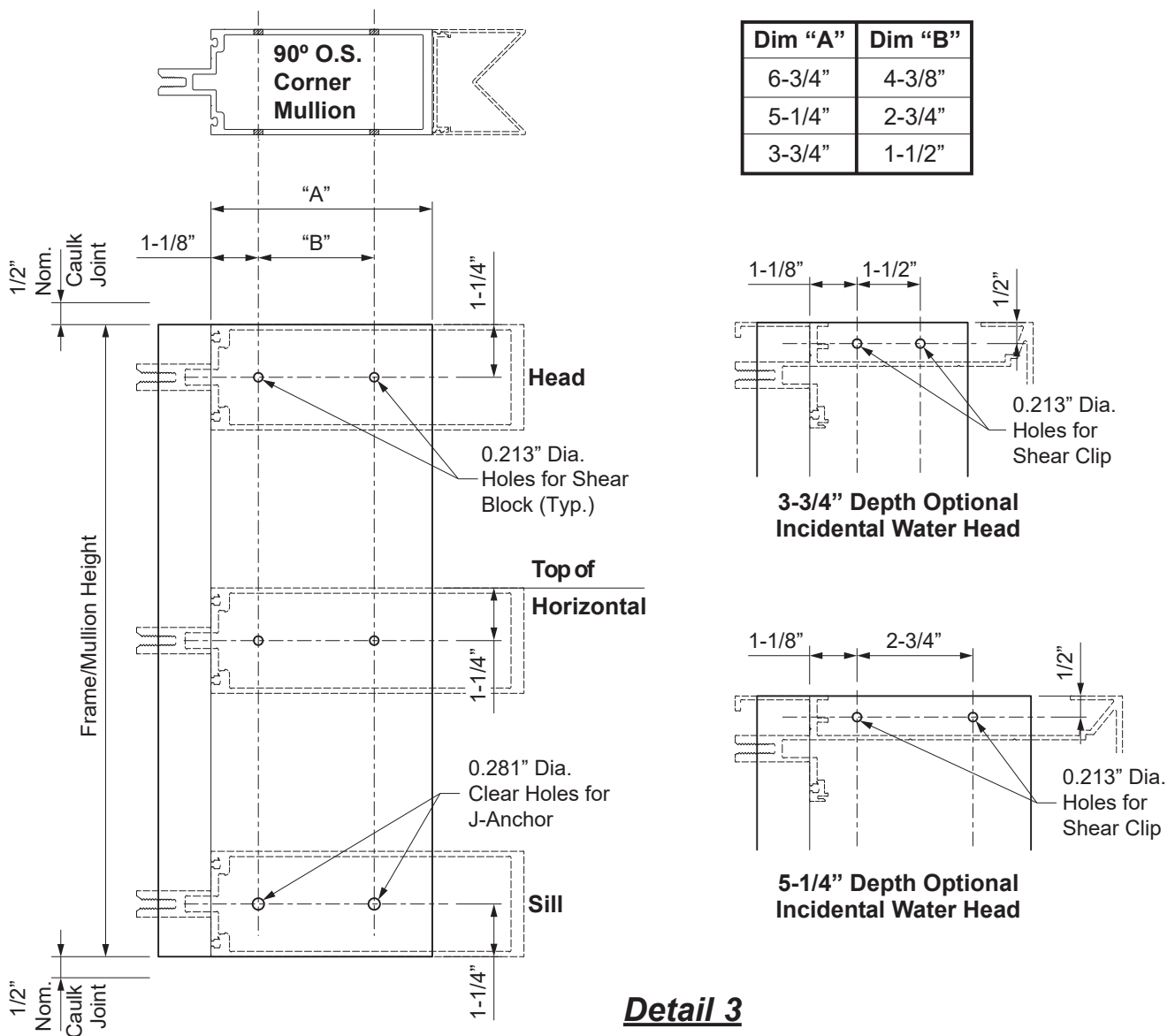

FRAME FABRICATION

**STEP 4 (Optional)
USING STEEL REINFORCING**

-Steel reinforcing must be primed/coated to insulate the steel from the aluminum.

When engineering calculations require the vertical mullions to be reinforced with steel, secure the reinforcing to the vertical using the appropriate fasteners.

- Start 3" from both ends of the mullion and install a fastener on both sides of the mullion tongue.
- Stagger the fasteners on either side of the tongue going up the vertical.
- Seal all screw heads with sealant.

Note: Exact size of reinforcing, size and location of fasteners to be determined by a qualified engineer.

Steel reinforcing is also attached on the sides of the mullion with the attachment of shear blocks.

- Drill 0.281" dia. (9/32 bit) clear holes in the mullion only.
- Match drill 0.213 dia. (#3 bit) tap holes in the reinforcing only.
- Attach the shear blocks with HF-2516-W1 fasteners.

See **Detail 4**.

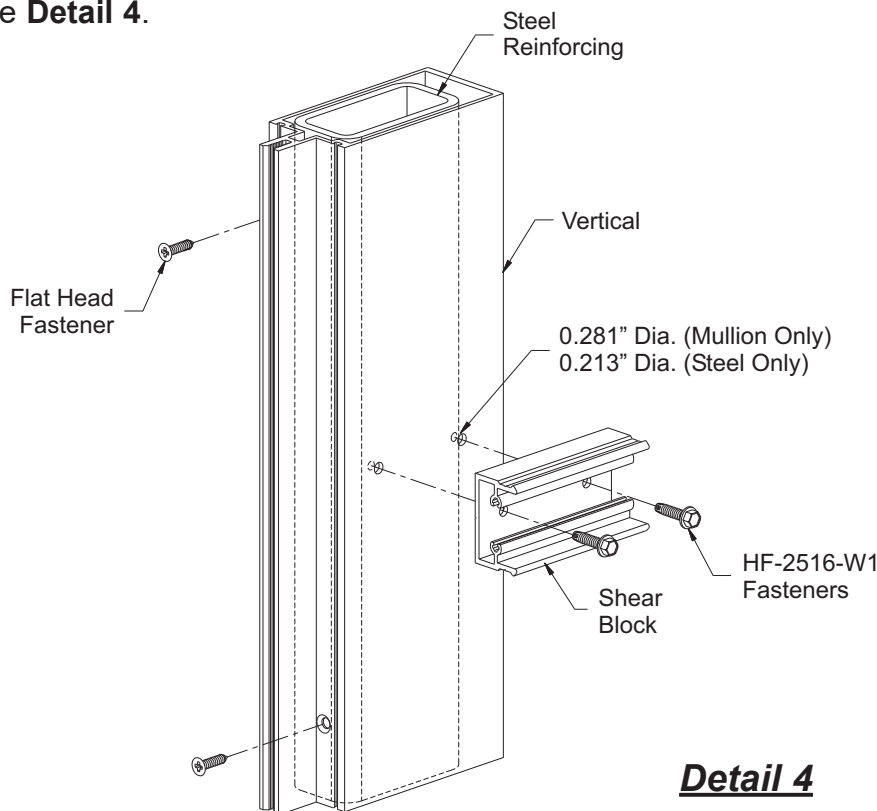

Detail 4

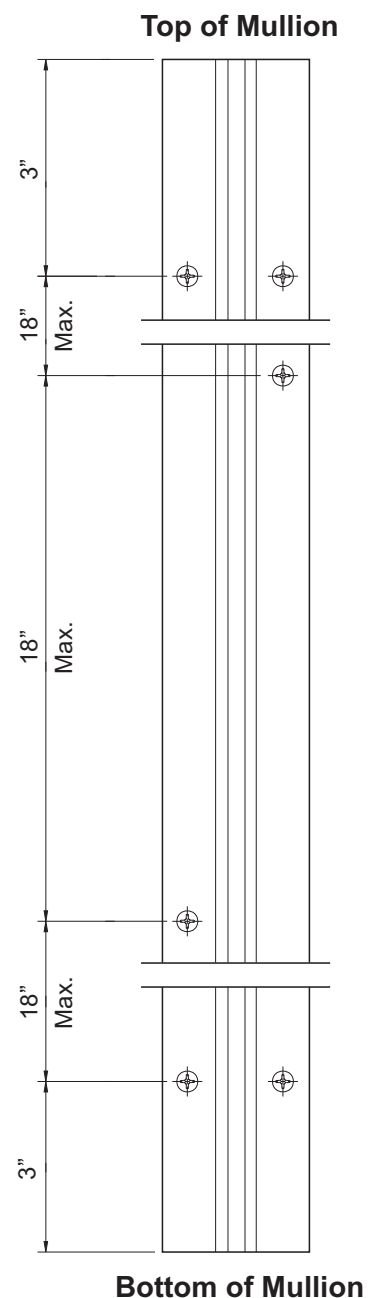

FRAME INSTALLATION

STEP 5

ASSEMBLE 90° OUTSIDE CORNER MULLIONS

- Drill 0.281" diameter clear holes into the corner mullion adaptor at 1-1/2" from each end and at 9" maximum on center.
- Fasten the corner mullion adaptor onto the corner mullion using HM-2516-W3 screws. Tighten the screws to 70 inch-pounds.

-Prior to attaching the corner shear blocks to the corner mullion, the interior covers must be installed. Attach the interior cover base E9-1280 to the back of the corner mullion with PC-1010 screws at 24" maximum on center. Then snap on the interior cover.

See **Detail 5**.

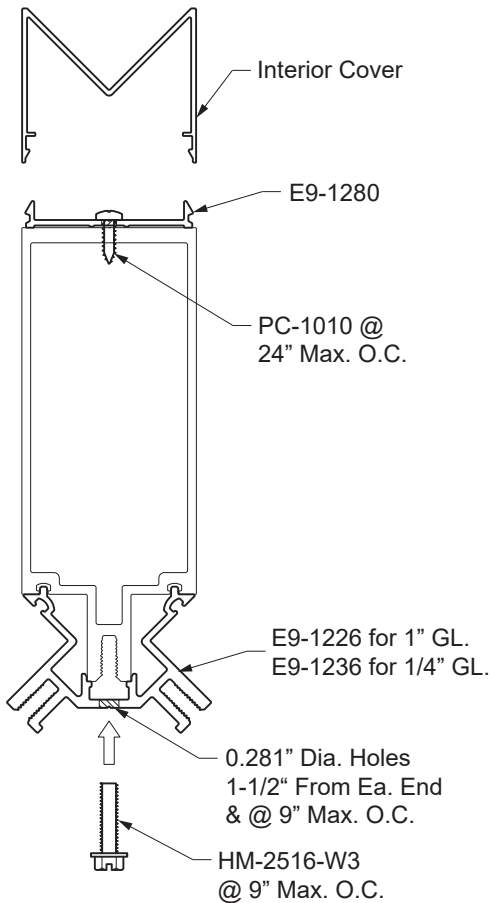

Detail 5

FRAME FABRICATION

**STEP 6
ATTACH SHEAR BLOCKS/CLIPS FOR HORIZONTALS**

Standard shear blocks are used to attach horizontal members to the jambs and verticals. Shear blocks for E-Slots (E1-1200, E1-1206 & E1-1236) are attached the same way.

E1-3503 for 3-3/4" back members.

E1-3504 for 5-1/4" back members.

E1-3506 for 6-3/4" back members.

-Attach shear blocks to jambs and verticals with (2) HF-2510-W1 fasteners per block.

Shear clips are used to attach optional incidental water head members to the jambs and verticals.

E1-3523 for 3-3/4" back members.

E1-3019 for 5-1/4" back members.

-Attach shear clips to jambs and verticals with (2) HF-2528-W1 fasteners per block.

See **Detail 6**.

Note: Do not attach standard shear blocks at the head and sill for end bays at this time. See **Step 17** for head and sill end bay attachment.

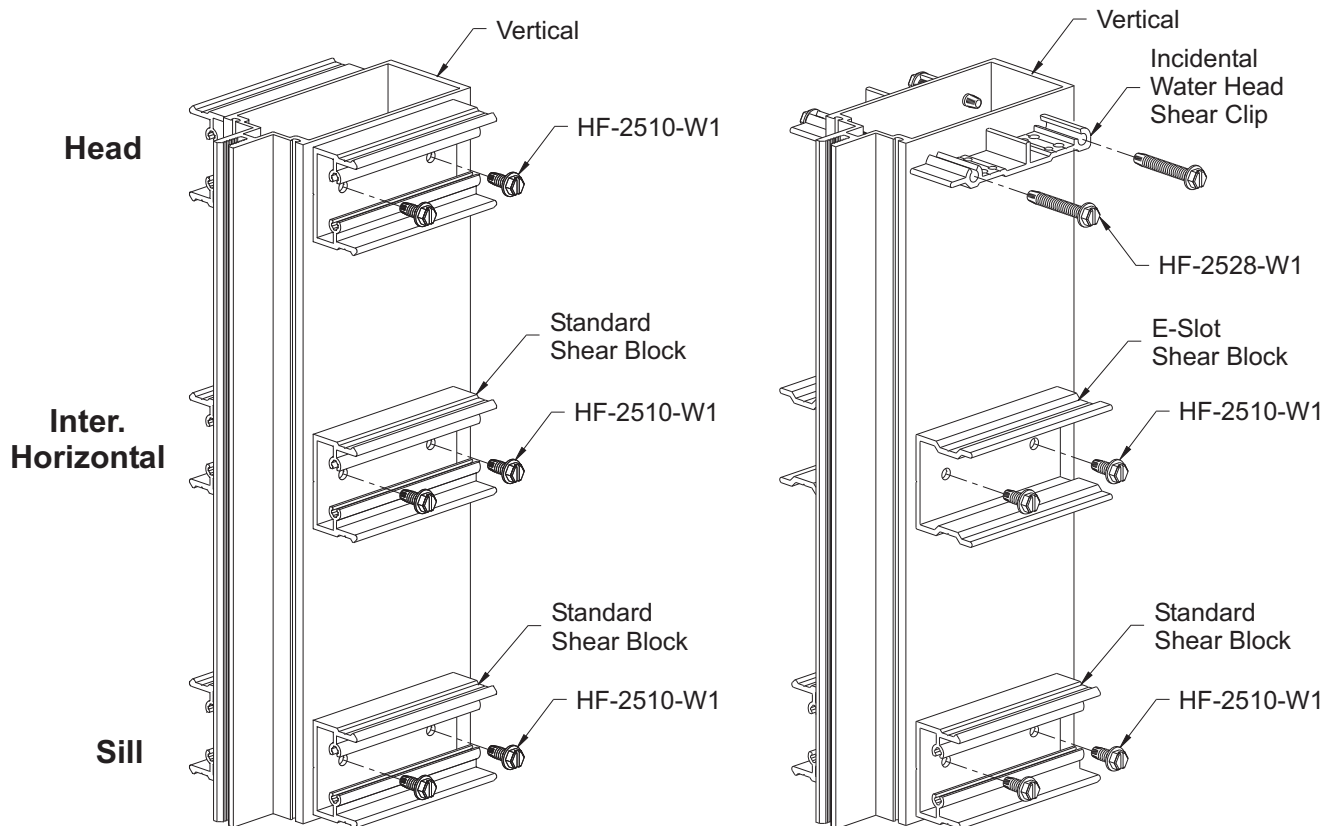

Detail 6

FRAME FABRICATION

STEP 6 (Continued)

ATTACH SHEAR BLOCKS FOR CORNER HORIZONTALS

Corner shear blocks/clips are used to attach horizontal members to the corner mullions:

- E1-3503A for 3-3/4" back members.
- E1-3504A for 5-1/4" back members.
- E1-3506A for 6-3/4" back members.

-Attach the shear blocks to jambs and verticals with two HF-2510-W1 fasteners per block (HF-2516-W1 where steel reinforcing is used.)

Shear clips are used to attach optional incidental water head members to the jambs and verticals.

- E1-3534/E1-3535 for 3-3/4" back members.
- E1-3532/E1-3533 for 5-1/4" back members.

See **Detail 7**.

- Additional fasteners may be required to accomodate special project conditions.
- Alternate holes can be utilized to correct fabrication errors.

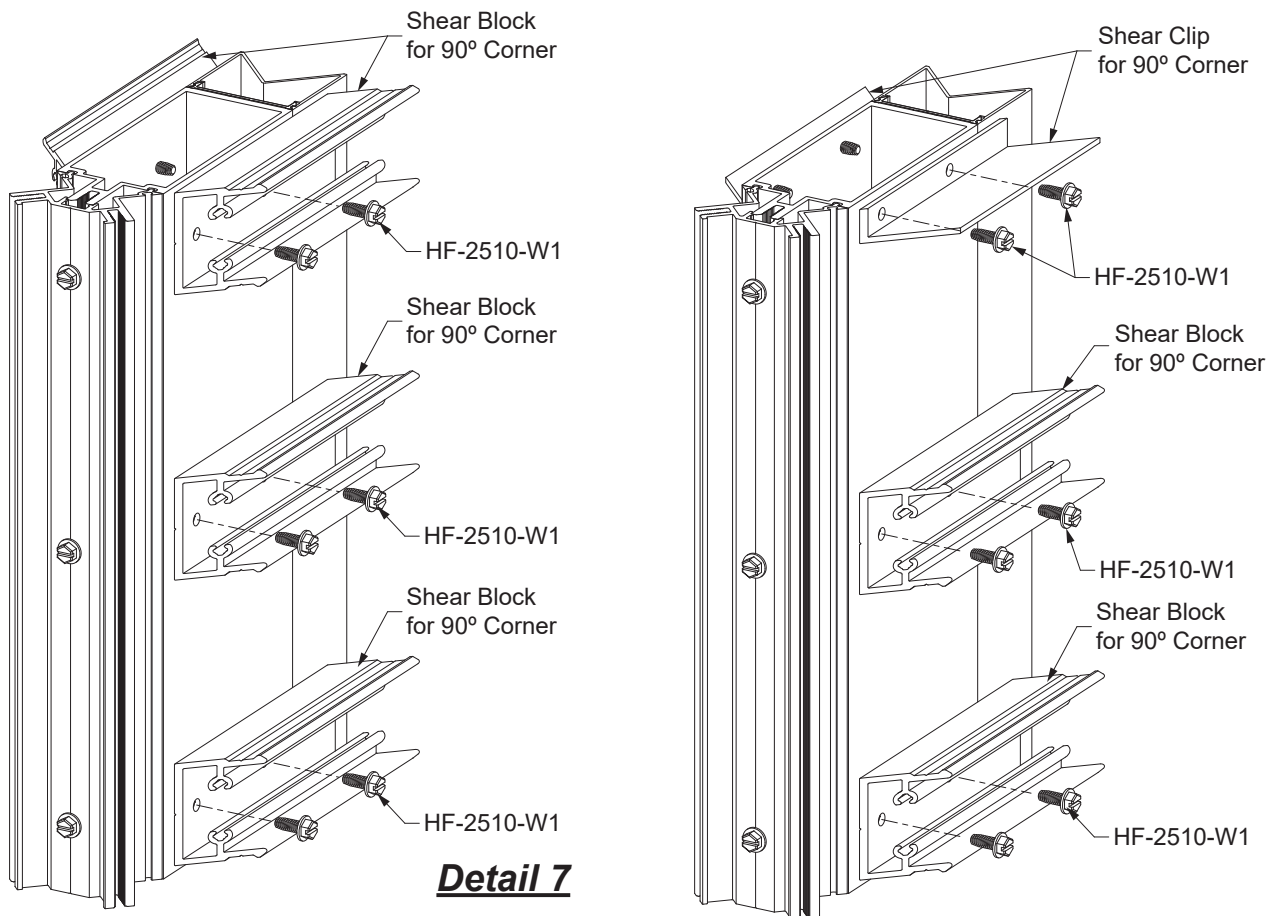

FRAME FABRICATION

**STEP 7
ATTACH “J” ANCHORS**

In addition to anchoring the curtain wall frame to the structure, “J” anchors are used to attach sill members to jamb and vertical mullions:

E1-3501 for 3-3/4” back members (E1-3501A/B at corner mullions)

E1-3502 for 5-1/4” back members (E1-3502A/B at corner mullions)

E1-3505 for 6-3/4” back members (E1-3505A/B at corner mullions)

Note: “J” anchors are used at the sill only.

Attach “J” Anchors at Jamb:

-Align the “J” anchor with the mullion and insert the HM-2516 bolts through the inside of the mullion and out the “J” anchor.

-Install 1/4” flat and lock washers between the anchor and HM-2500 hex nuts.

Attach “J” Anchors at Intermediate Verticals:

-Align the “J” anchors and insert the HM-2556 bolts through both anchors and the mullion.

-Install 1/4” flat and lock washers between the anchor and HM-2500 hex nuts.

See **Detail 8**.

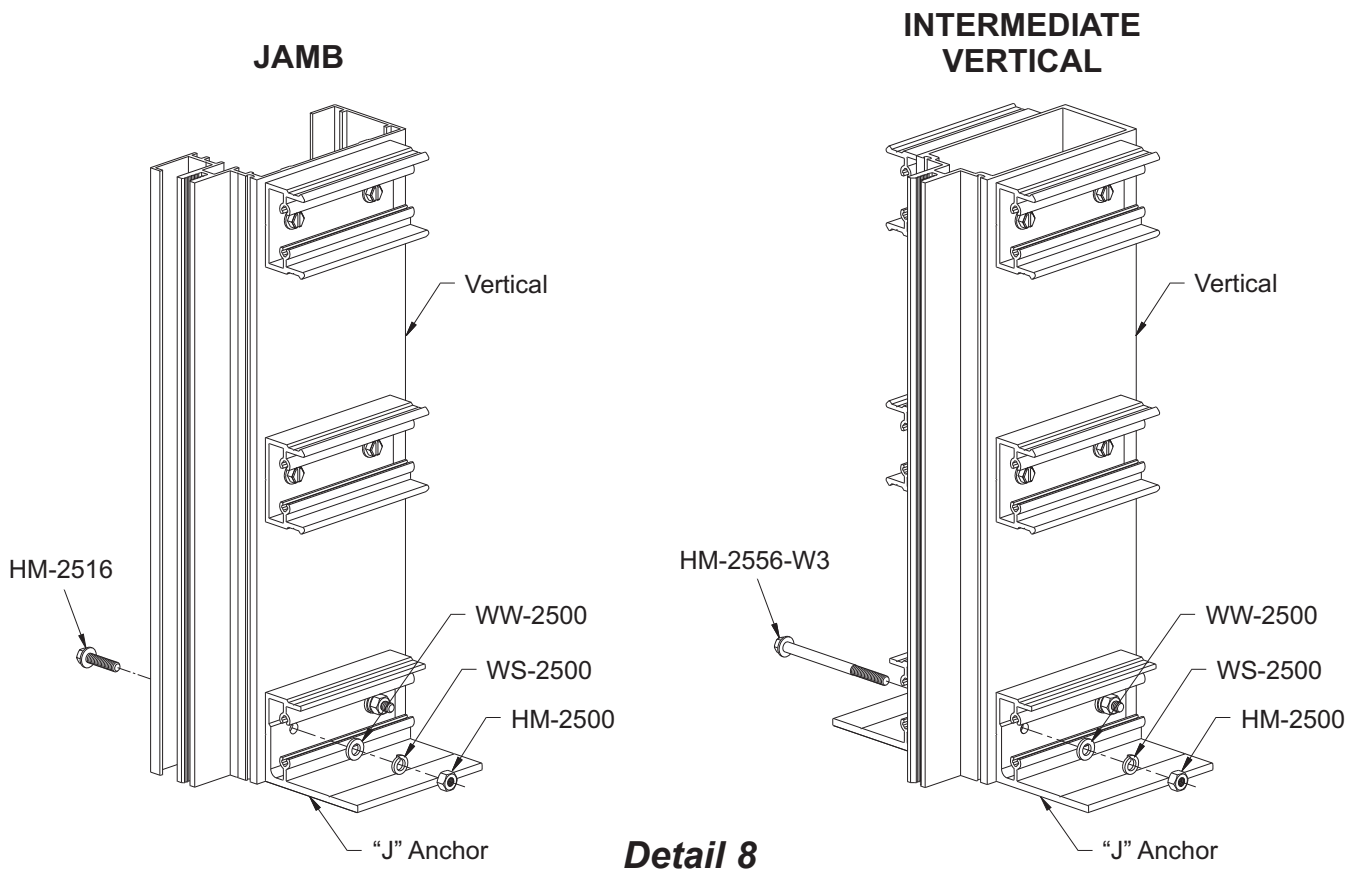

Detail 8

FRAME FABRICATION

**STEP 8
FABRICATE HORIZONTAL MEMBERS**

- Cut all horizontal members to the daylight opening as shown in shop drawings.
- Cut all horizontal flush fillers to the daylight opening minus(-) 1/32".
- Horizontal members must be fabricated for shear block/clip attachment as follows:

Horizontals with Concealed Fasteners (5-1/4" & 3-3/4" Back Depths Only):

- Layout hole locations on the face of the horizontal at both ends as shown below.
 - Drill 0.236" diameter (#B bit) holes and countersink for #12 flat head fasteners.
- See **Detail 9**.

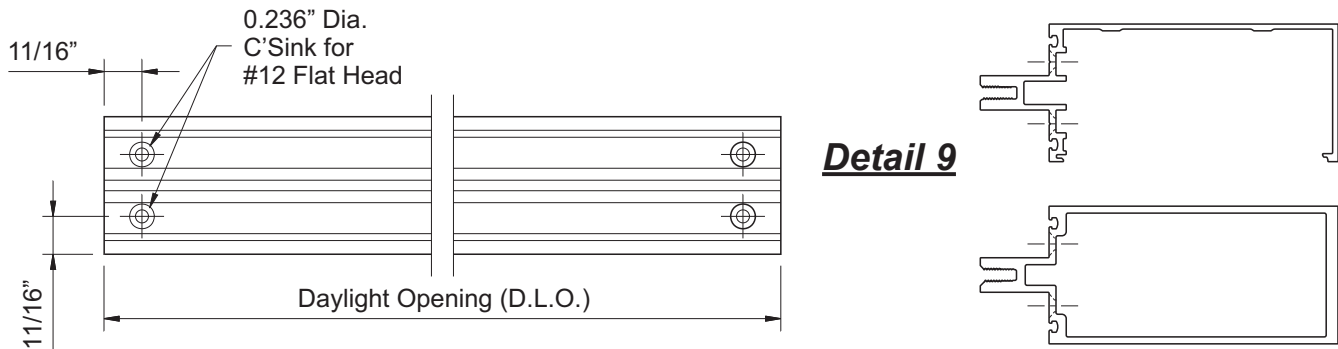

Detail 9

Horizontals with Exposed Fasteners:

- Layout hole locations on the top of the horizontal at both ends as shown below.
 - Drill 0.236" diameter (#B bit) holes and countersink for #12 flat head fasteners.
- See **Detail 10**.

Dim "A"	Dim "B"
6-3/4"	4-3/8"
5-1/4"	2-3/4"
3-3/4"	1-1/2"

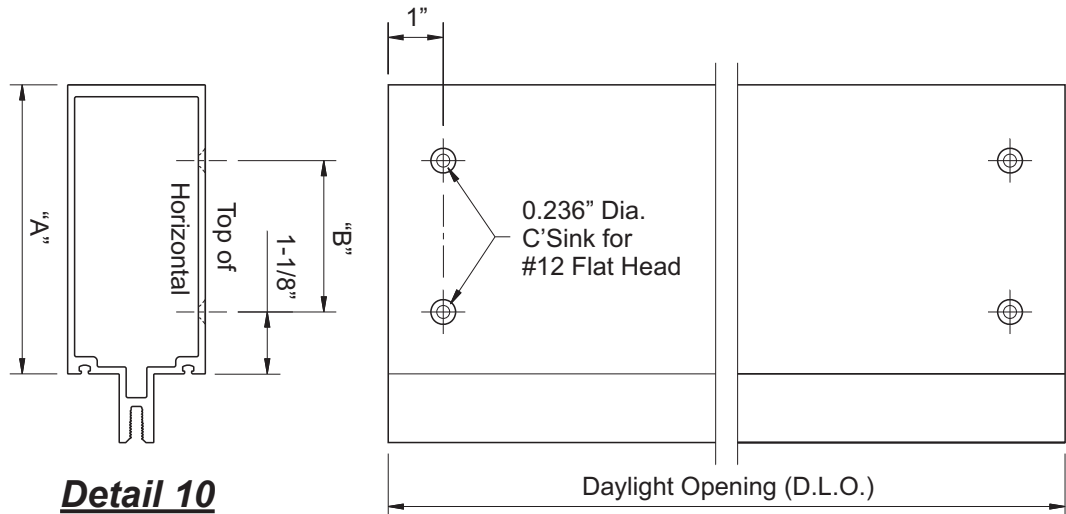

Detail 10

FRAME FABRICATION

**STEP 8 (Continued)
FABRICATE HORIZONTAL MEMBERS**

Open Back Head & Sill with “T” & “F” Anchors (5-1/4” & 3-3/4” Back Depths Only):

- Open back head & sill members require holes to access anchor bolts.
- Drill 1-1/2” dia. holes at anchor locations as required by approved shop drawings or engineering calculations.

See **Detail 11**.

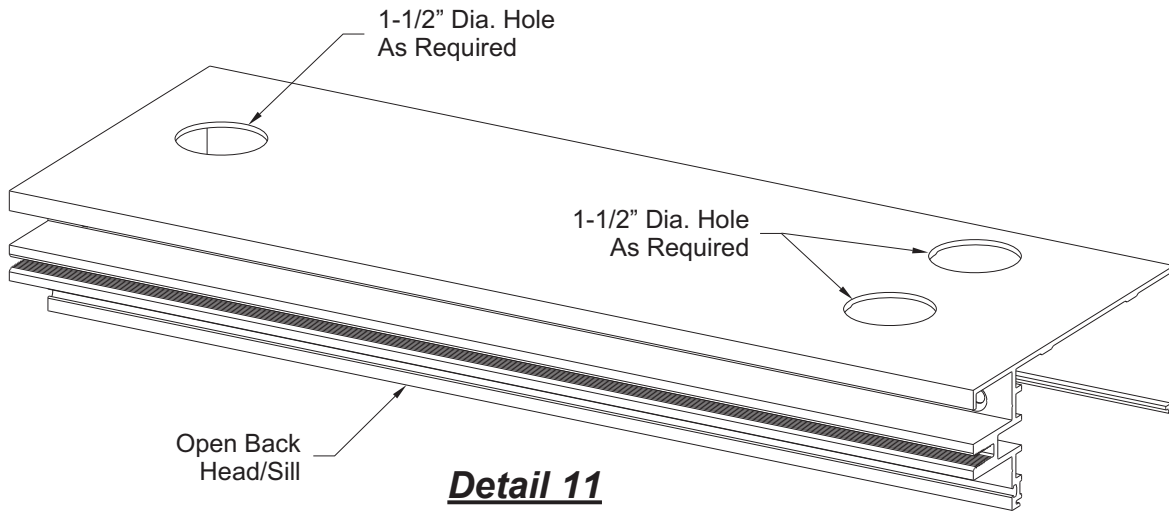

Tubular Head & Sill with “J”, “F” & “T” Anchors:

- Tubular head and sill members must be notched at each end to clear mullion end anchors and anchor bolts.
- See **Detail 12** below for notch dimensions.

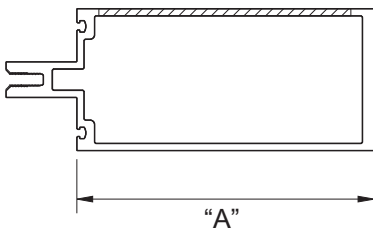

**Notch Horizontal
Ends to Clear
End Anchors
& Anchor Bolts**

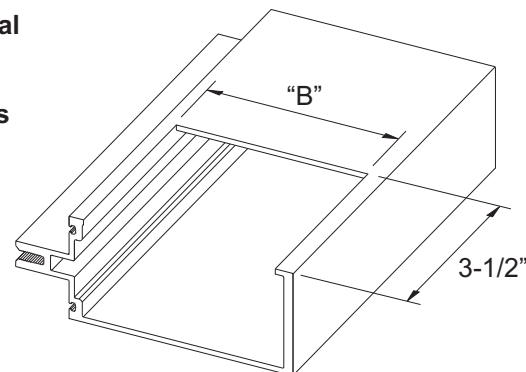

Dim “A”	Dim “B”
6-3/4”	6-1/4”
5-1/4”	4-3/4”
3-3/4”	3-1/4”

Detail 12

FRAME FABRICATION

STEP 8 (Continued)
FABRICATE HORIZONTAL MEMBERS

Optional Incidental Water Head (5-1/4" & 3-3/4" Back Depths Only):

- Layout hole locations on the bottom of the horizontal along the "V"-grooves at both ends.
- Drill 0.213" diameter (#3 bit) holes at each location.

Incidental water head members require weep holes along the top face of the mullion.

- Layout hole locations along the "V"-Groove of the top face as required according to approved shop drawings or engineering calculations.
- Drill 0.313" diameter weep holes at each location.

See **Detail 13**.

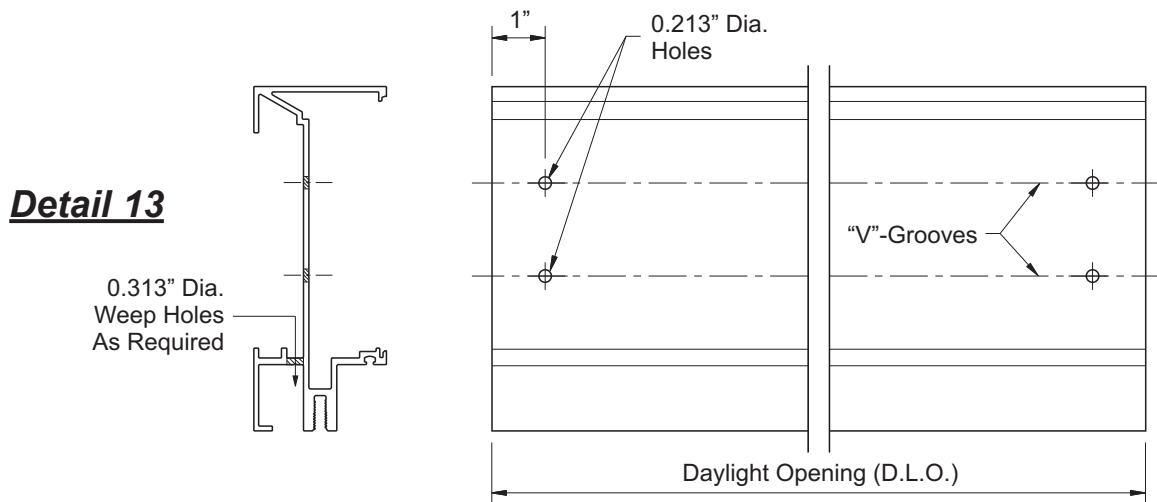

Optional Slide-In Tubular Horizontals at End Bays (E-SLOT):

When using tubular horizontals at end bays, horizontals must slide in from the interior.

- In order to clear the shear blocks on the verticals, notch the face and tongue of the horizontal at both ends as shown below.

See **Detail 14**.

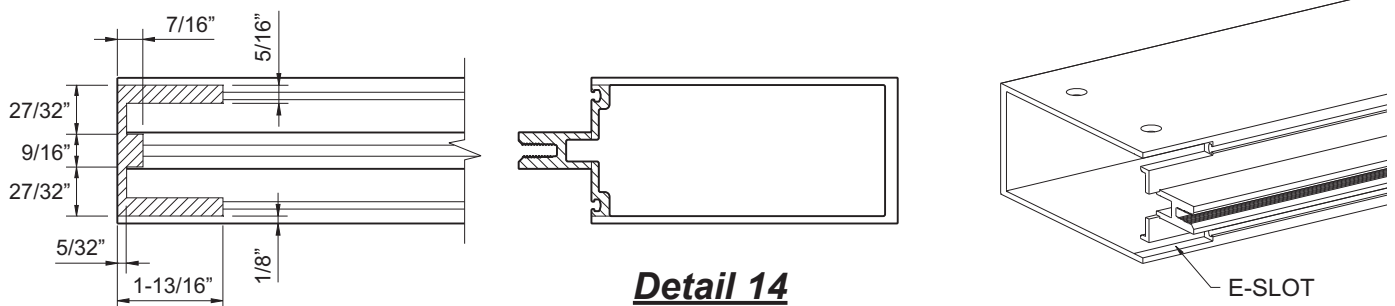

FRAME FABRICATION

**STEP 8 (Continued)
FABRICATE HORIZONTAL MEMBERS**

Horizontals at 90° O.S. Corner:

- Cut all horizontal members to the daylight opening as shown in shop drawings.
 - Horizontal members must be fabricated as shown below to attach to shear blocks or clips.
 - Layout hole locations on the top of the horizontal at the mitered ends as shown below.
 - Drill 0.236" diameter (#B bit) holes and countersink for #12 flat head fasteners.
- See **Details 15, 17 & 19.**

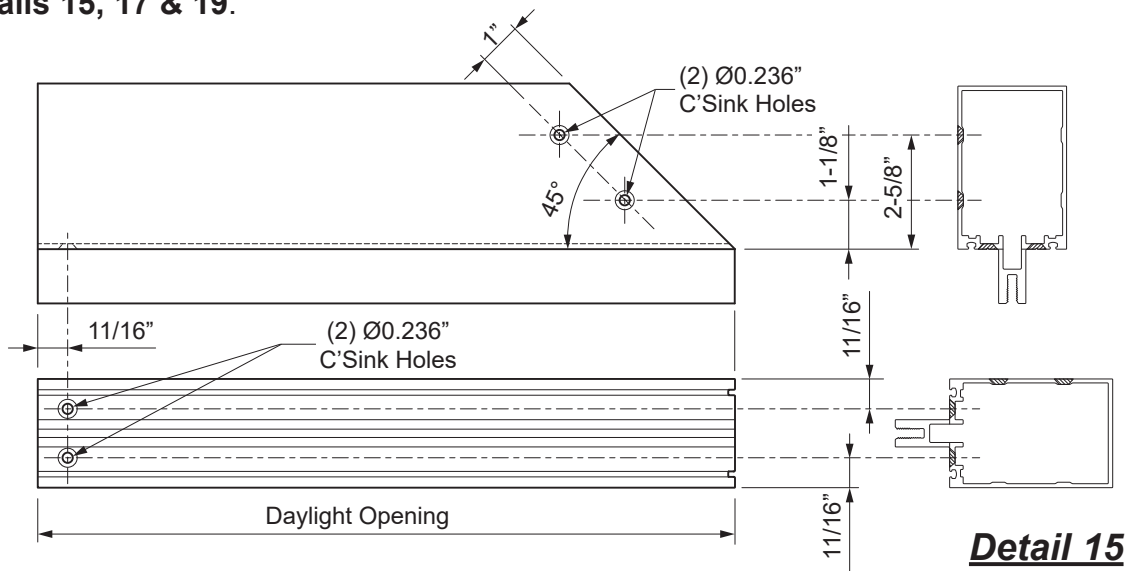

Incidental Water Heads at 90° O.S. Corner:

- Layout hole locations on the bottom of the horizontal along the "V"-grooves at both ends.
 - Drill 0.236" diameter (#B bit) holes at each location.
- Be careful not to penetrate the outer wall of the mullion.
- See **Details 16 & 18.**

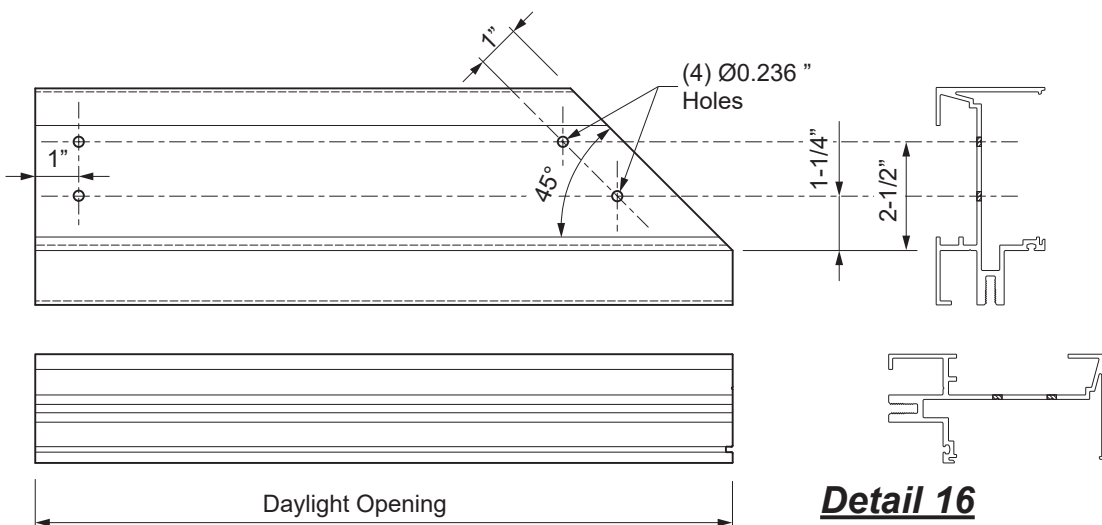

FRAME FABRICATION

STEP 8 (Continued)
FABRICATE HORIZONTAL MEMBERS

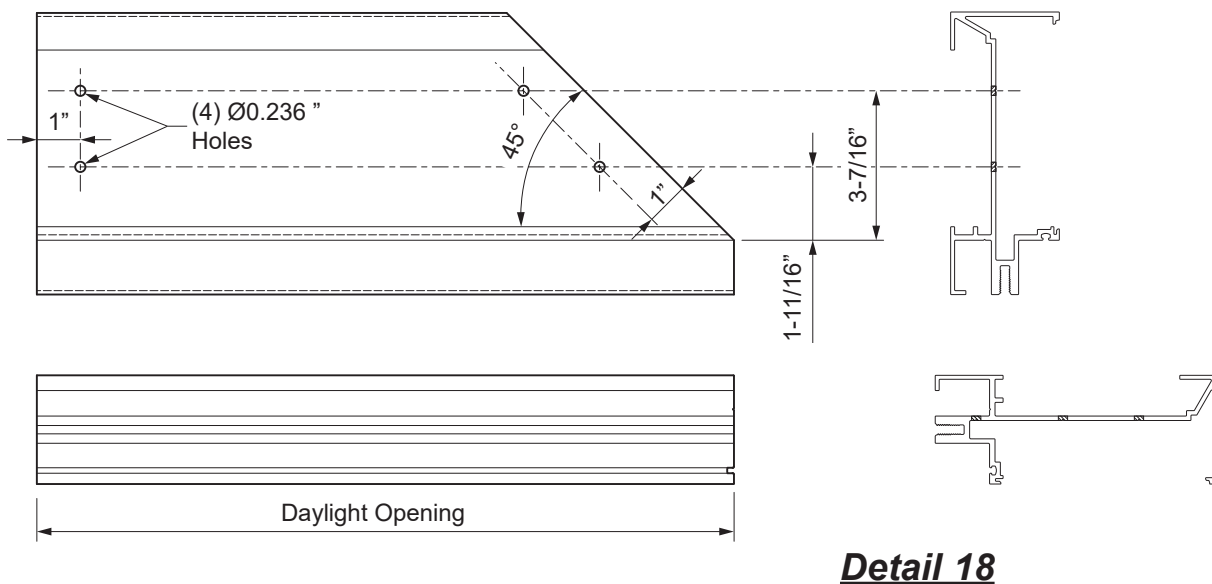
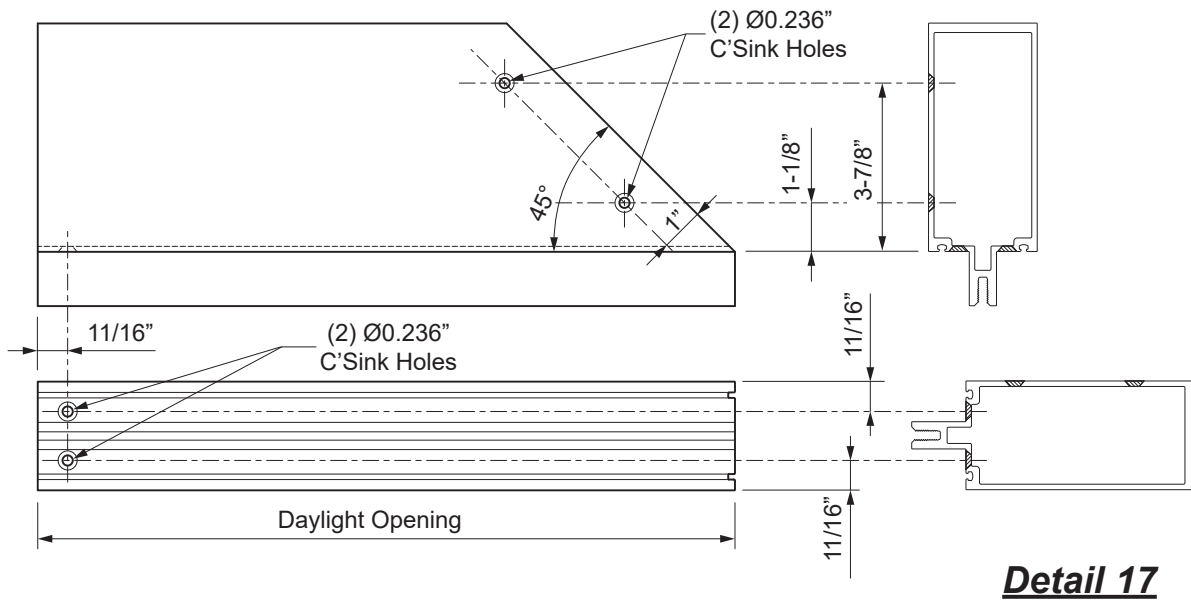

FRAME FABRICATION

STEP 8 (Continued)
FABRICATE HORIZONTAL MEMBERS

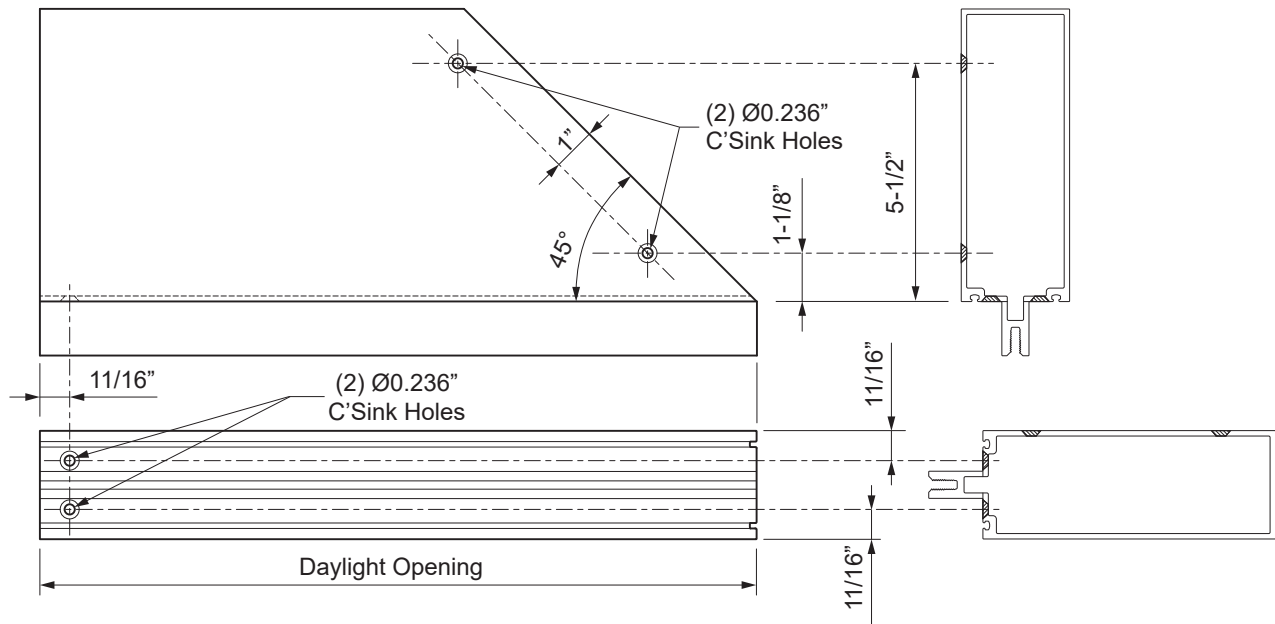

Detail 19

FRAME FABRICATION

STEP 9 FABRICATE PRESSURE PLATES

Horizontal Pressure Plates:

- Cut horizontal pressure plates to the daylight opening between verticals minus(-) 1/4".
 - Pressure plate stock lengths have 0.281" dia. holes factory drilled every 9".
After cutting, drill additional holes if required to ensure that end holes are 1-1/2" from each end.
 - If factory drilled holes are less than 1-1/2" from the ends, they must be sealed and not used.
 - Drill two 0.313" (5/16") diameter weep holes 3" from each end and one at the centerline of the pressure plate.
- See **Detail 20**.

Note: If the space between the weep holes exceeds 3', additional weep holes should be drilled to ensure that there is no more than 3' between the weep holes.

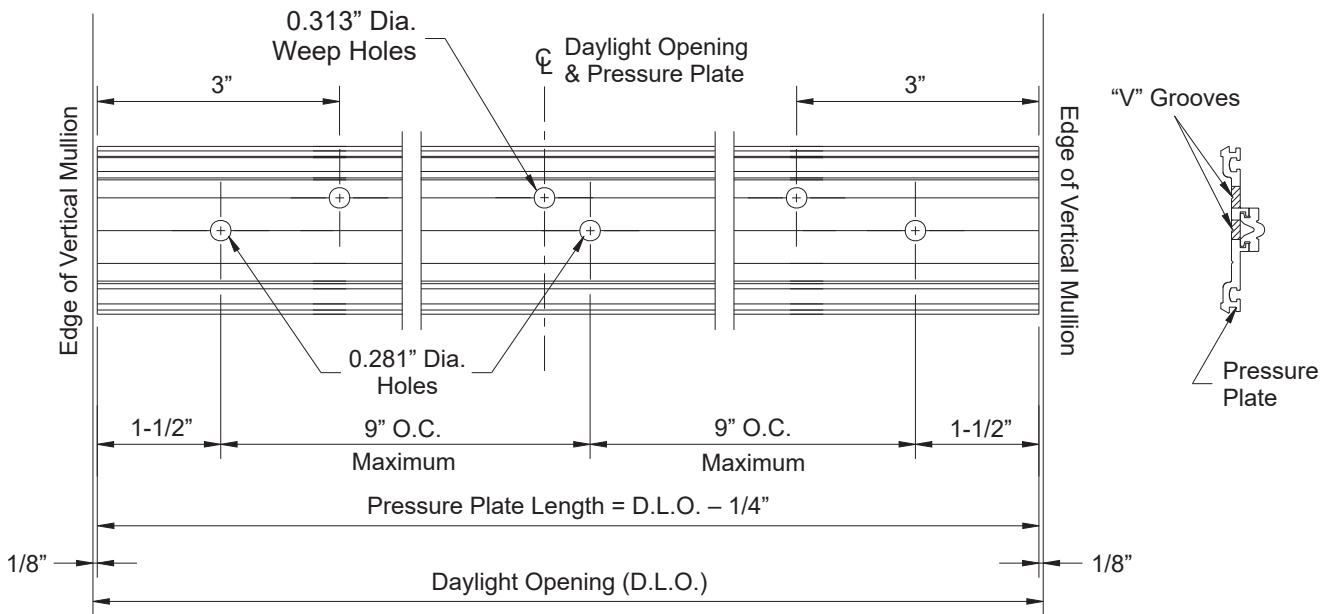

Detail 20

Vertical Pressure Plates:

- Cut vertical and jamb pressure plates to the same length as the vertical mullions.
- If vertical mullions are spliced, cut pressure plates to accommodate for 1/2" expansion joint as shown in **Step 11** on **Pages 25 & 26**.
- Drill additional attachment holes if required to ensure that end holes are at 1-1/2" from each end.

FRAME FABRICATION

**STEP 10
FABRICATE FACE COVERS**

Horizontal Face Covers:

- Cut horizontal face covers to the daylight opening between verticals minus(-) 1/16".
- Drill two 0.313" diameter weep holes at 1/3 points of cover as shown below.

See **Detail 21**.

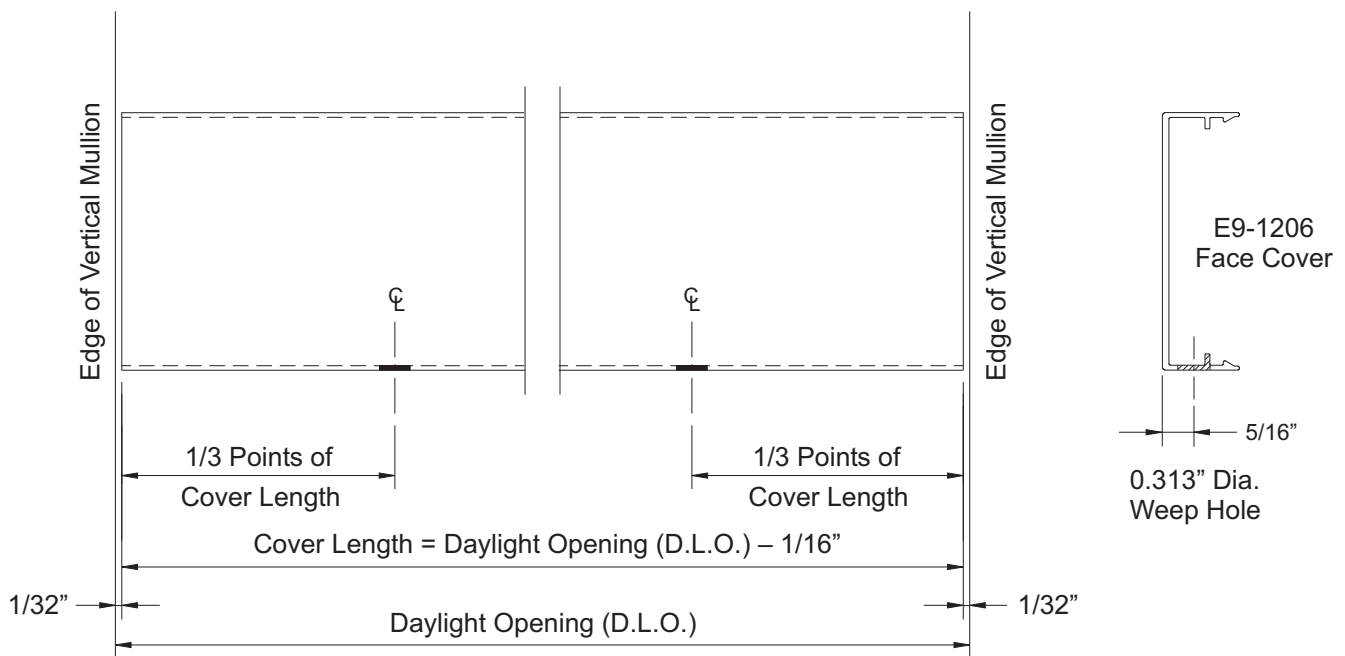

Detail 21

Vertical Face Covers:

- Cut vertical face covers to the same length as the vertical mullions unless the verticals are spliced.
- If vertical mullions are spliced, cut vertical covers to accommodate for the 1/2" expansion joint as shown in **Step 11**.

FRAME INSTALLATION

STEP 11
TYPICAL VERTICAL SPLICE

Stagger Mullion, Pressure Plate, and Cover Splice Joints as Shown Below.

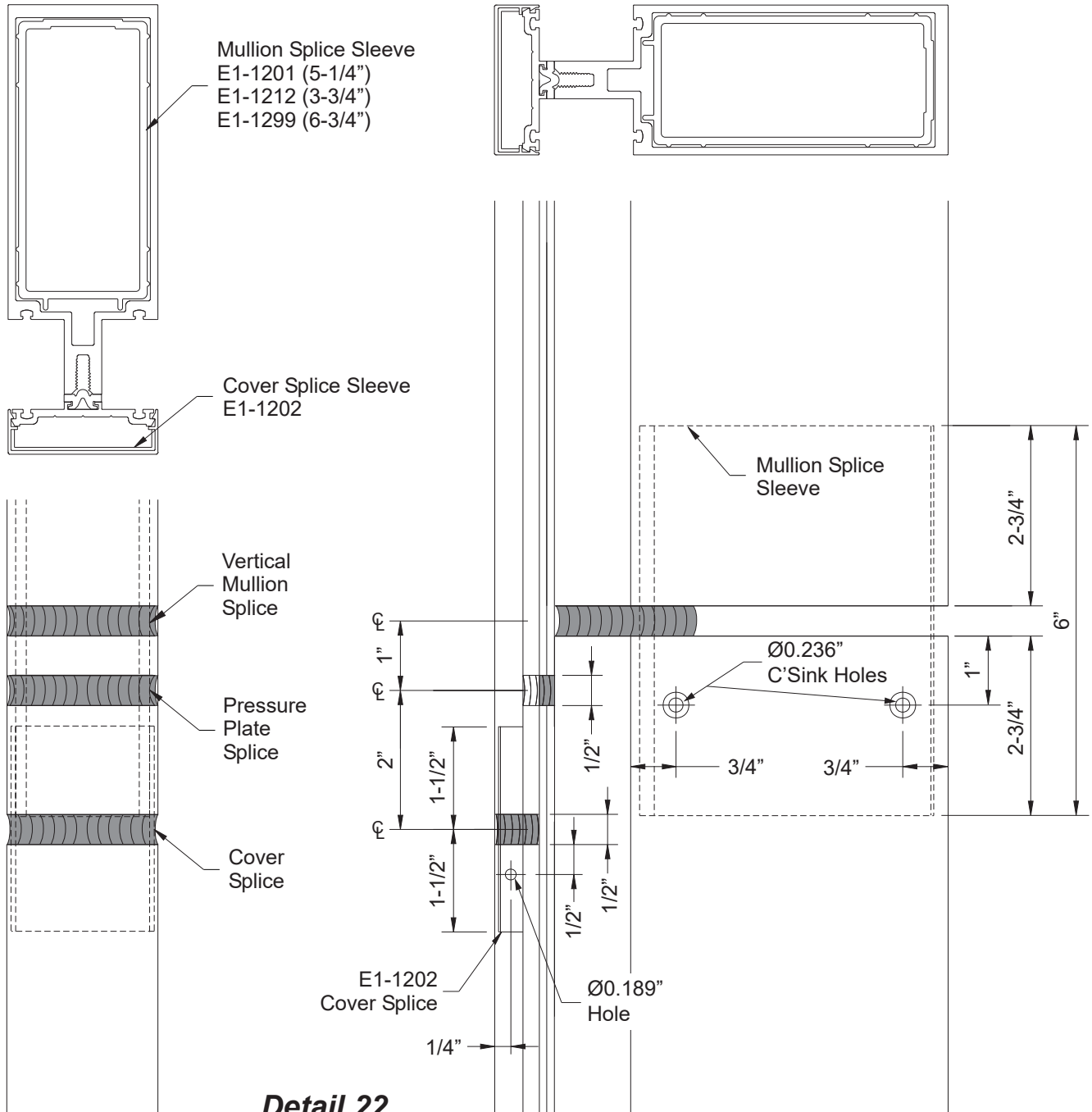

Detail 22

FRAME INSTALLATION

**STEP 11 (Continued)
TYPICAL VERTICAL SPLICE**

- Clean all surfaces as recommended by sealant manufacturer.
- At 3/4" from the front and back of the lower mullion and down 1" from the top, drill Ø0.236" (#B drill bit) holes, and countersink for #12 flat head fasteners, on each side of the mullion.
- Apply bond breaker tape to the face of the splice sleeve at its midpoint (3" from top or bottom).
- Lower the splice sleeve into top of lower mullion 2-3/4" and attach with two FC-1212 fasteners on both sides of the mullion.
- When using 1" glazing mullions, stuff a small piece of backer rod 1/2" down the cavity behind mullion tongue and pump in sealant to fill the cavity.
- Apply sealant to the face of splice sleeve on the upper half and carefully slide the upper mullion down onto the splice sleeve. Place a 1/2" temporary shim between the mullions to locate them.
- Secure the upper mullion to the mid anchors and remove the temporary shims.
- Apply and tool sealant to the face and sides of the splice sleeve to create a water tight joint.

- Leave a 1/2" expansion joint between vertical pressure plate splices and fill the joint with sealant.
- Locate pressure plate fasteners 1-1/2" from each end of pressure plate splice as shown.
- Apply bond breaker tape to the face of the cover splice sleeve and attach it to the lower face cover with a PF-0808-SS fastener on each side.
- Prior to snapping on the upper portion of the face cover, apply sealant to the face of the splice.
- Leave a 1/2" expansion joint between face cover splices.

See **Details 22 & 23**.

Note: Face covers, pressure plates, and mullions are staggered at splice locations.

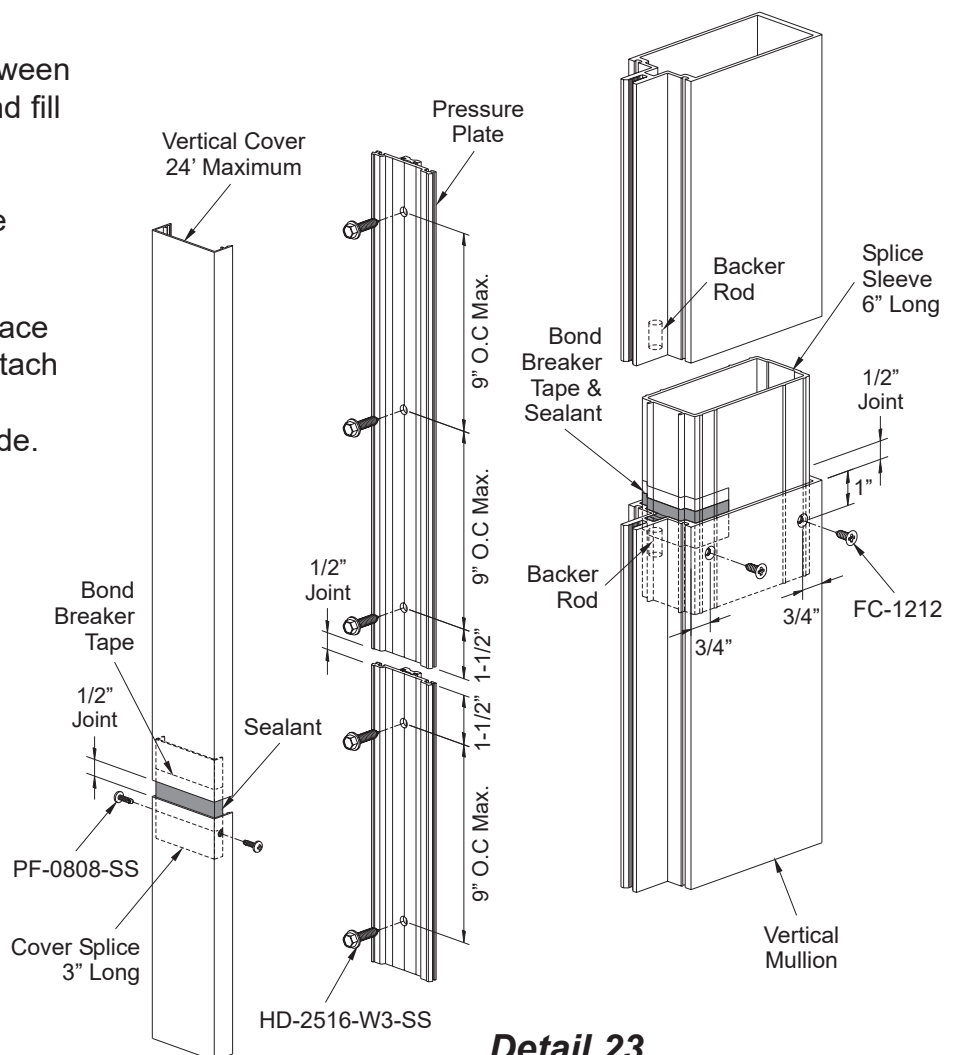

Detail 23

FRAME INSTALLATION

**STEP 12 (When Required)
INSTALL CONTINUOUS PERIMETER ANCHOR**

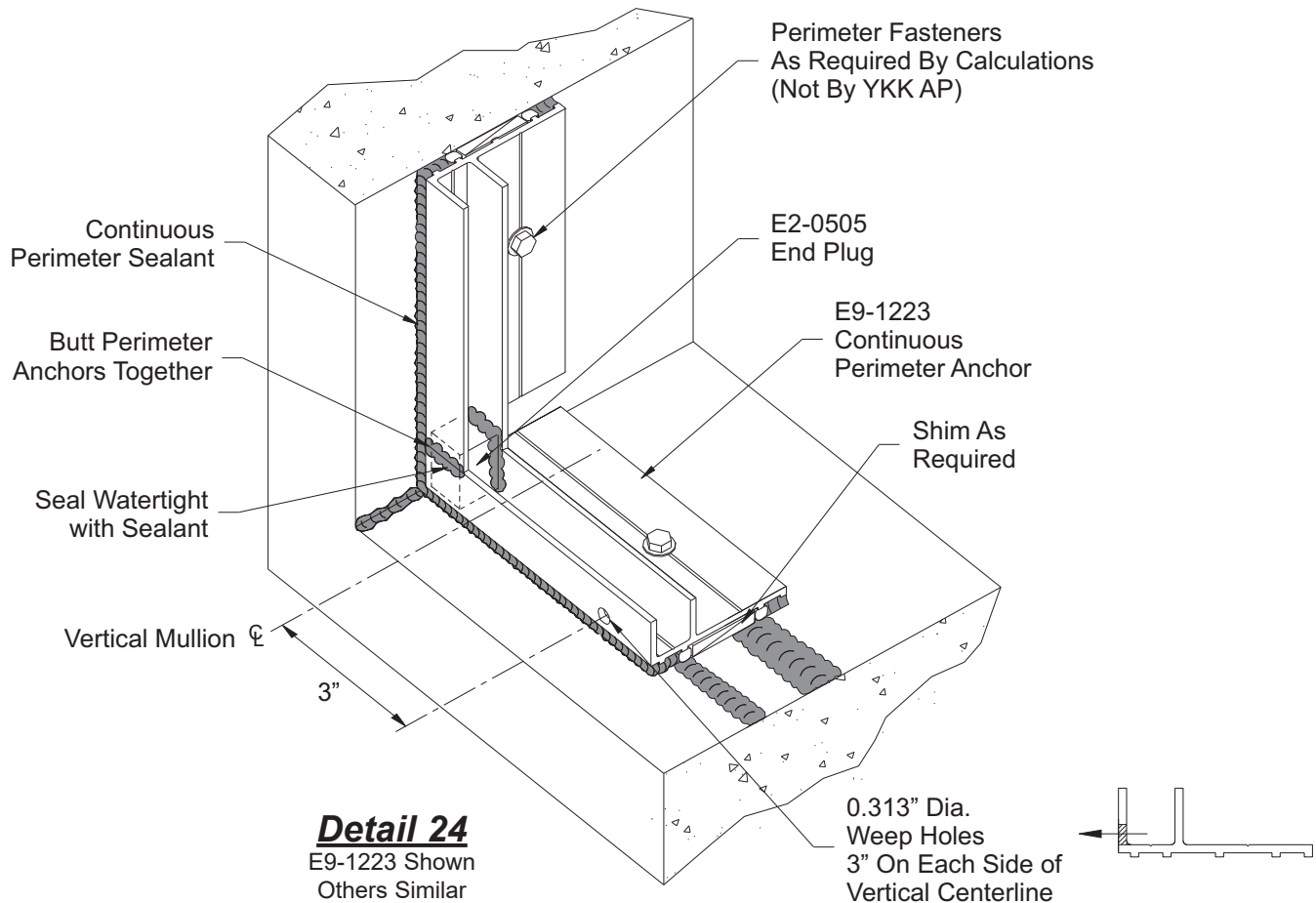

Detail 24
E9-1223 Shown
Others Similar

- Cut perimeter anchors to size:
 - Head and sill anchors stop 1/8" short of the structure.
 - Vertical jamb anchors butt in between head and sill anchors.
- Prepare structure for anchor attachment.
- Install perimeter anchors with appropriate perimeter fasteners. Refer to shop drawings or engineering calculations for type and spacing of fasteners. Shim as required to install anchors level.
- When splicing head and sill pieces together, leave 3/8" joint for expansion and install end plug, E2-0505, that has been buttered with sealant on the front, back, and bottom at the joint.
- Run continuous sealant along the perimeter between the anchors and the substrate.
- Seal corners of butted perimeter anchors watertight with sealant.
- Butter E2-0505 end plug with sealant on all sides that touch the anchors. Then push end plug into place and tool excess sealant that comes through the cracks.
- Field drill 0.313" diameter weep holes in perimeter anchor (exterior face only) at sill only, 3" from center line of vertical on each side.

See **Detail 24**.

FRAME INSTALLATION

**STEP 13 (When Required)
JAMB/VERTICAL INSTALLATION
WITH PERIMETER ANCHORS**

- The notched ends of vertical mullions for 1" glazing leaves the interior of the mullion exposed and must be plugged prior to installation.
- Install a small piece of backer rod into the notched out space directly behind the tongue at the top and bottom of the vertical mullions.
- Push the backer rod into the opening at the face of the mullion.
- Apply and tool sealant to seal off the opening made by the notch.

- Install interior gasket, E2-0120, to jamb mullion (jamb side only) the full length of the mullion.
- Position jamb into opening as shown below.
- Seal the gap between the perimeter anchor and vertical glazing pocket(s) with sealant (one side for jambs – both sides for intermediate verticals).
- Install temporary retainer clip, E1-1294, at the top and bottom of the mullion.
- Repeat this step for all jamb and vertical mullions.

See **Detail 25**.

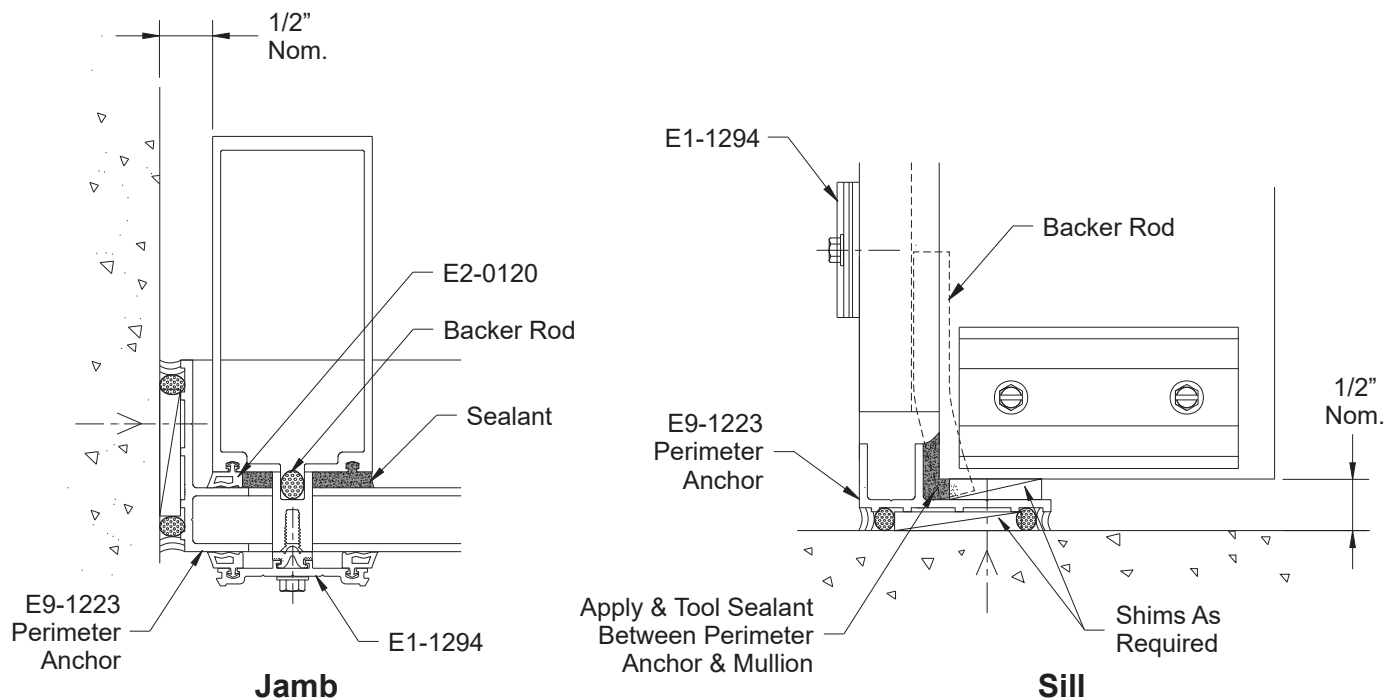

Detail 25
E9-1223 Shown
Others Similar

FRAME INSTALLATION

STEP 14 (Optional)
JAMB INSTALLATION WITH JAMB ANCHORS

Optional jamb anchor clips, E1-3524 for 3-3/4" back depth and E1-3525 for 5-1/4" back depth, may be used with open back jamb members to reduce deflection at the jambs.

- Locate the jamb anchor locations on the structure according to approved shop drawings.
- Strike a plumb line the length of the frame height at the center line of the anchor fasteners.
- Provide anchor fasteners as per approved shop drawings or engineering calculations.
- Install the anchor fasteners as recommended by fastener manufacturer.
- Install the jamb mullions as instructed in the next step.

Note: Jamb anchor clips must be installed plumb and line up straight with each other.

See **Detail 26**.

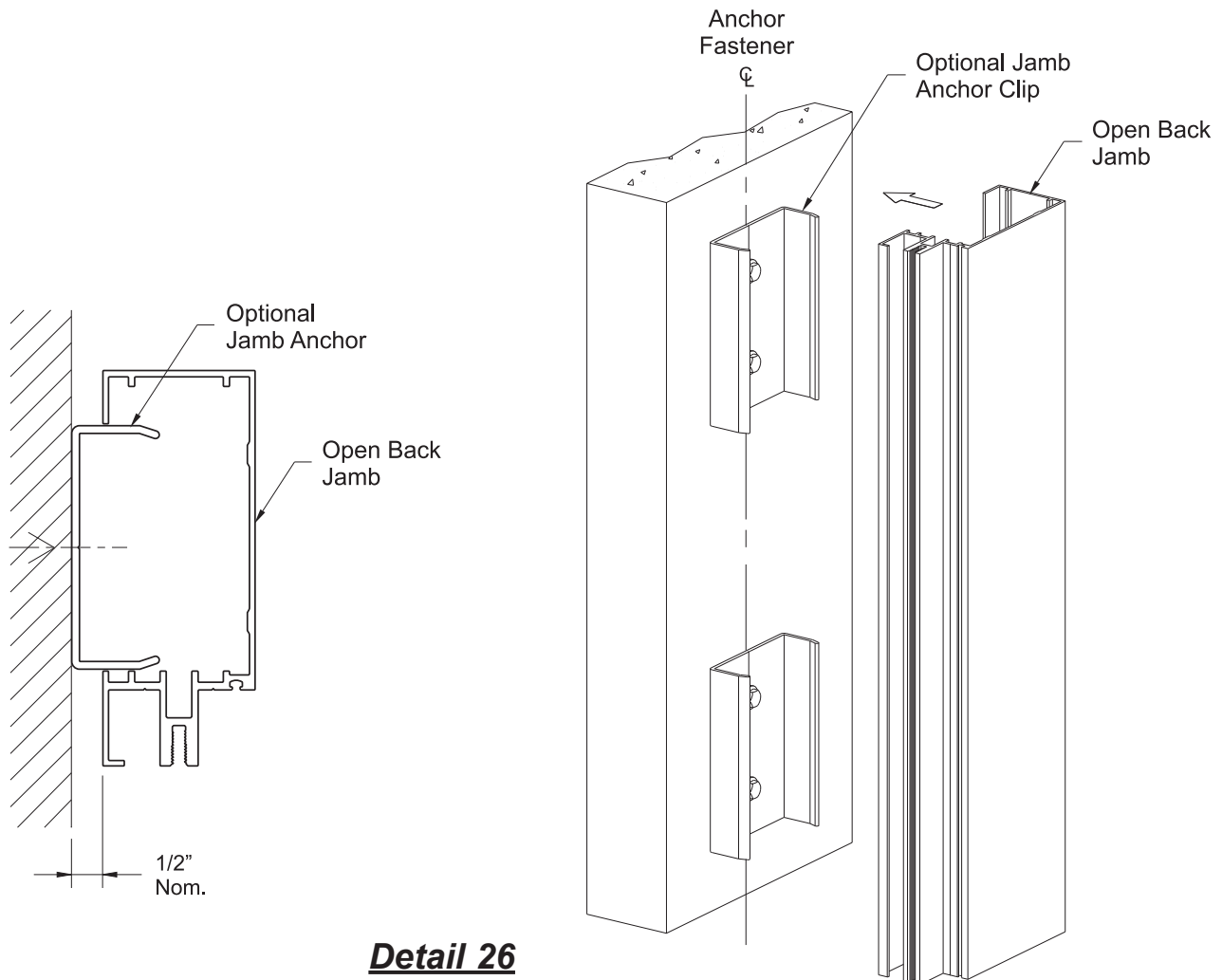

Detail 26

FRAME INSTALLATION

**STEP 15
JAMB/VERTICAL INSTALLATION
WITH MULLION END ANCHORS**

- Clean all contact surfaces as recommended by sealant manufacturer.
- Apply sealant into the screw raceway and along the front edge of the mullion at each end.
- Prior to erecting verticals, install mullion end caps with FC-1410 fasteners.
- Seal all screw heads with sealant.

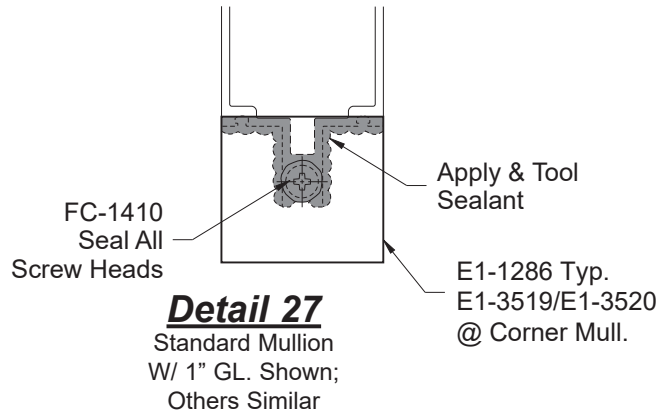

See **Detail 27**.

Note: End caps are not required at the bottom of the door jamb mullions as they run flat against the substrate.

- Insert mullion "T" and "F" anchors into the top and bottom of the mullions before erecting them into the opening.
- Erect and locate the jamb and vertical mullions and temporarily attach them to the structure. All mullions must be installed plumb and true.
- Drill through the pre-drilled holes in "T", "F" and "J" anchors into the structure for the appropriate anchor fasteners according to approved shop drawings or engineering calculations.

See **Detail 28**.

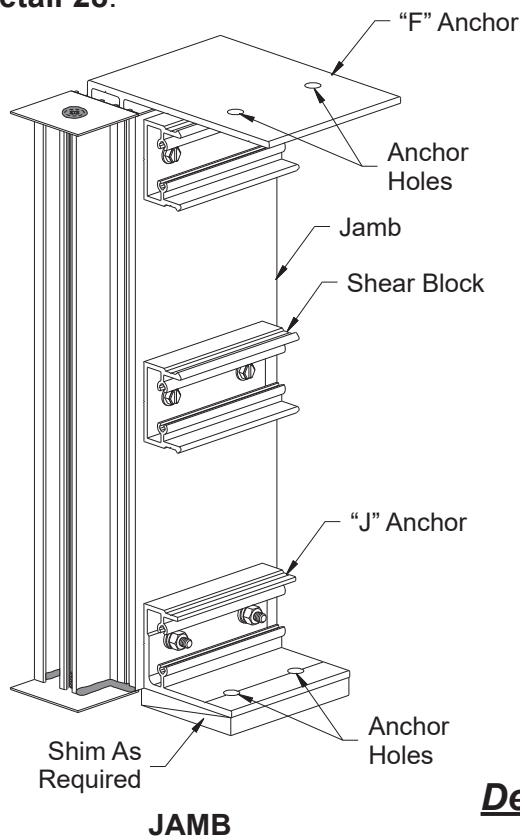

Detail 28

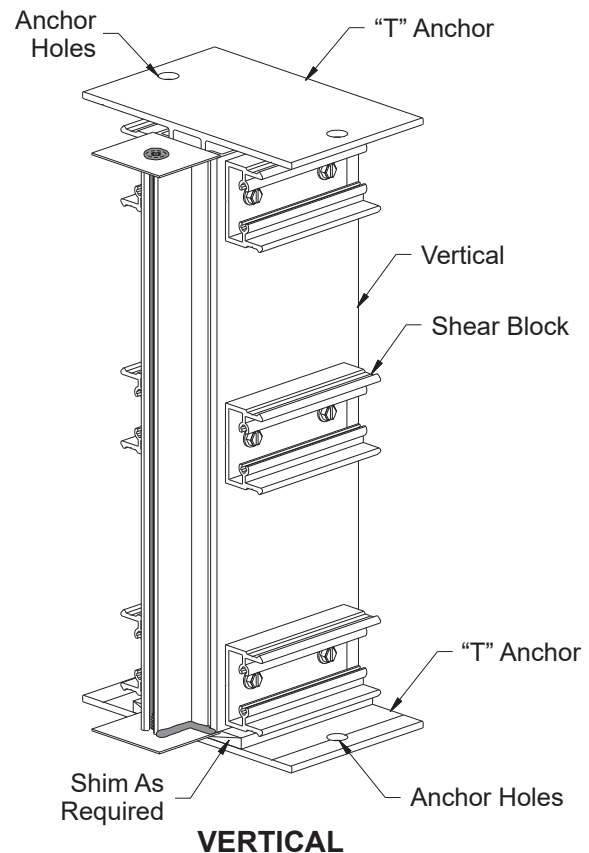

FRAME INSTALLATION

STEP 15A
VERTICAL INSTALLATION
AT DOOR JAMB END ANCHORS

The mullions at the door jambs are set directly upon the sill substrate without any shims and are sealed against the substrate. The anchors to be used at this location are specified by the approved shop drawings and or P.E. calculations.

-Locate the mullion anchor for the door jamb and install it to the substrate according to the approved shop drawings and P.E. calculations.

Note: if using an exposed fasteners shear block as a mullion anchor, check to ensure the sill shear block fasteners will not cause interference. Field modify the shear block anchor as required. See **Detail 30**.

-Clean all contact surfaces as recommended by sealant manufacturer.
 -Set the mullion on the anchor, directly onto the sill substrate in a bed of sealant. Avoid using shims at this location. See **Detail 29**.

-Refer to the approved shop drawings for any additional fasteners required.
 -Tool sealant at the bottom of the mullion at the sill substrate around the perimeter of the mullion. See **Detail 31**.

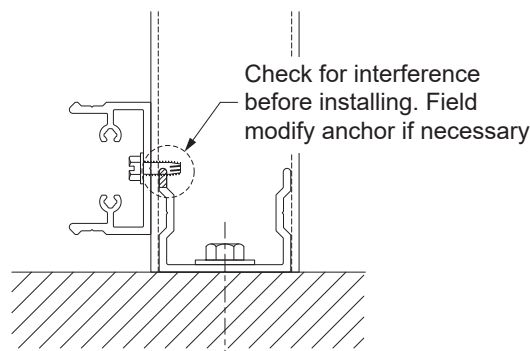
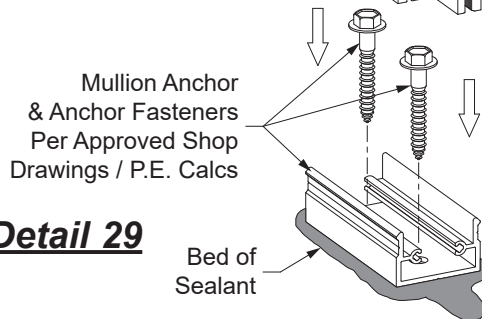
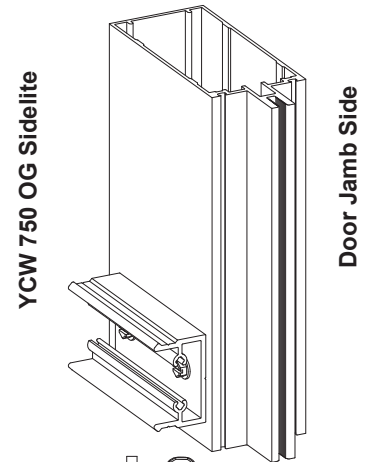

Detail 30
 For Exposed Fasteners Shear Block Used as Anchor

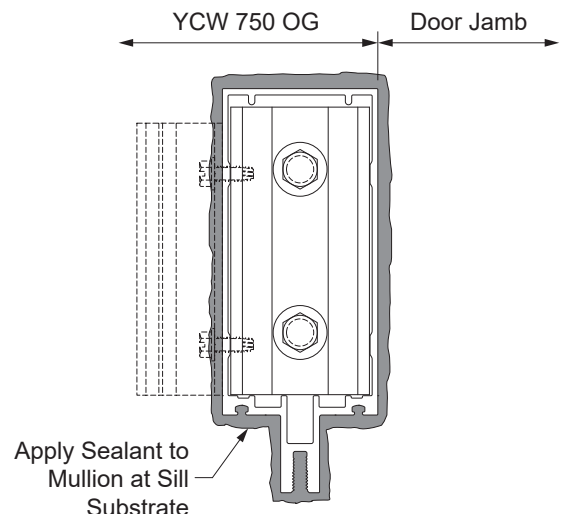

Detail 31

FRAME INSTALLATION

**STEP 16
INSTALL WIND LOAD/DEAD LOAD ANCHORS**

-Install steel wind load and dead load anchors. Anchor are normally template or line set before mullions are hung. Outstanding leg of anchor must be set at 90° to offset line. The back of the vertical mullion should set about 1" from the anchoring substrate.

-Torque all anchor bolts to 90 inch-pounds.

See **Detail 32**.

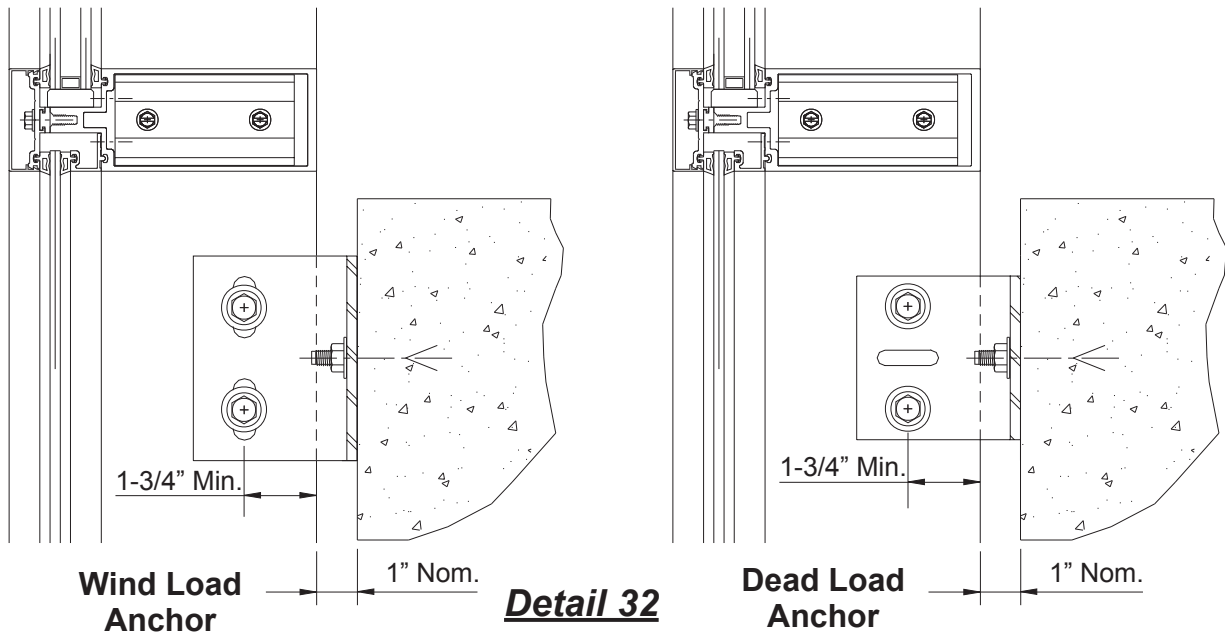

-Install, plumb, and align vertical mullions. Drill and install appropriate diameter anchor bolts per approved shop drawings or engineering calculations.

-Nylon slip pads, E3-0103, must be installed between mullion and anchors.

See **Detail 33**.

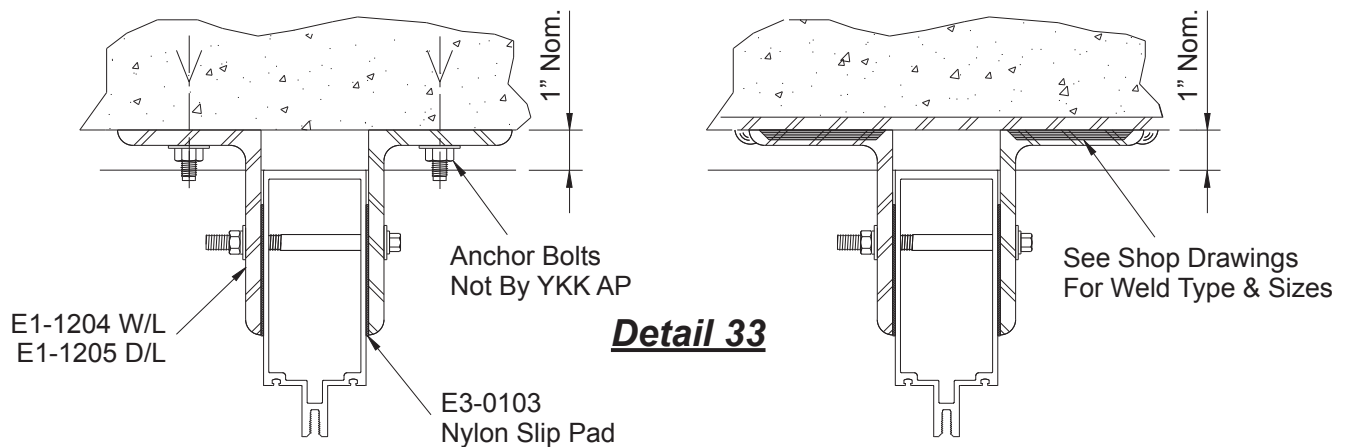

FRAME INSTALLATION

TYPICAL WIND LOAD ANCHOR

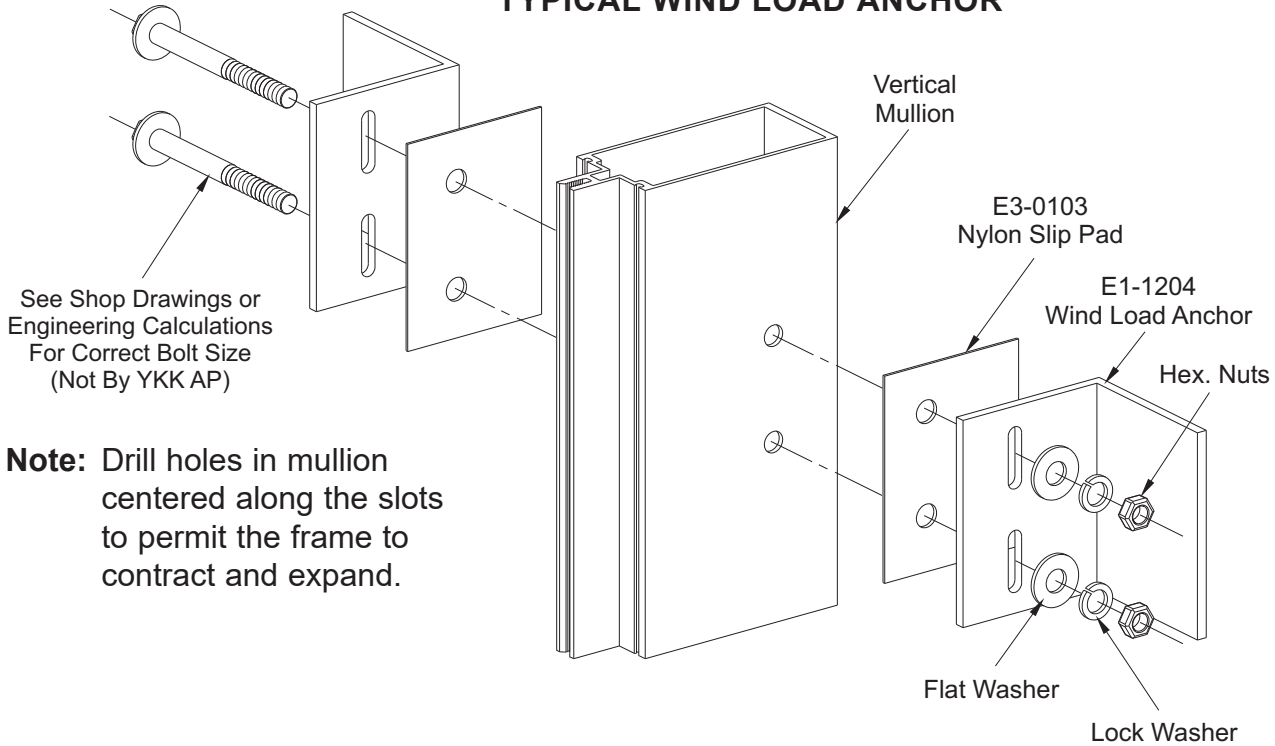

Detail 34

TYPICAL DEAD LOAD ANCHOR

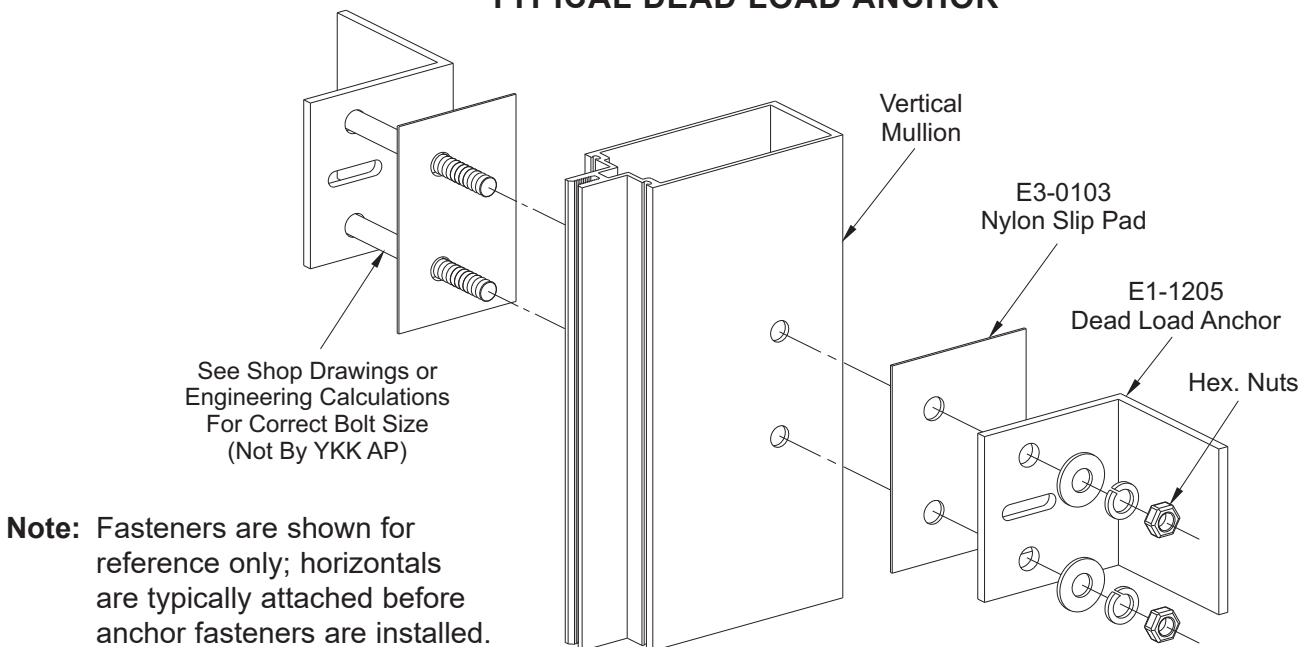

FRAME INSTALLATION

JAMB WIND LOAD ANCHOR

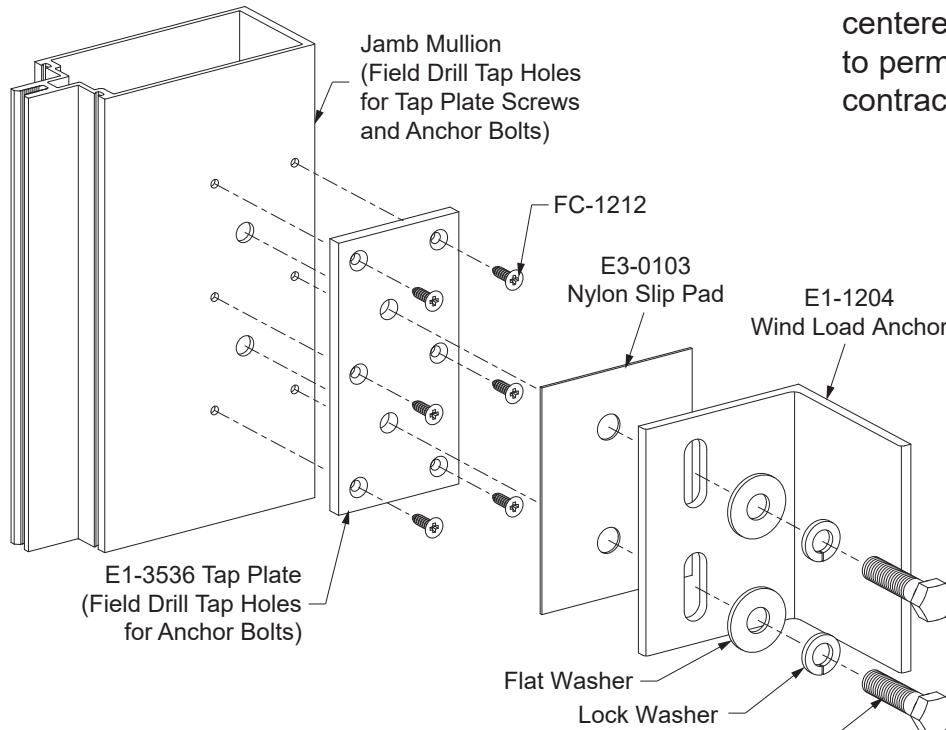

Note: Drill holes in mullion centered along the slots to permit the frame to contract and expand.

JAMB DEAD LOAD ANCHOR

Detail 34A

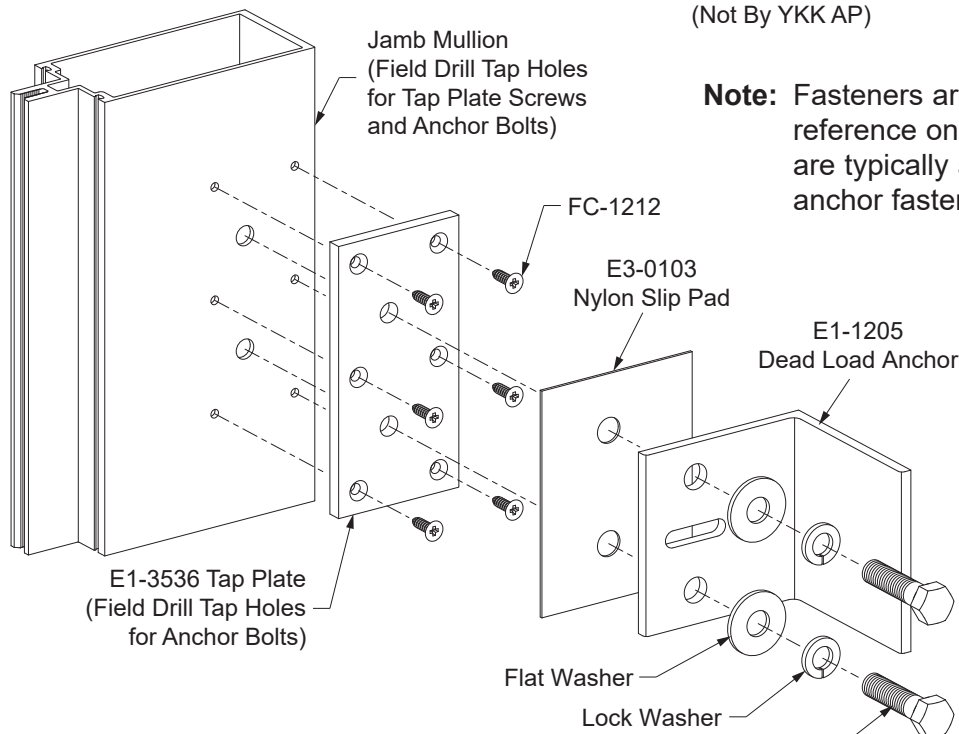

See Shop Drawings or Engineering Calculations For Correct Bolt Size (Not By YKK AP)

Note: Fasteners are shown for reference only; horizontals are typically attached before anchor fasteners are installed.

See Shop Drawings or Engineering Calculations For Correct Bolt Size (Not By YKK AP)

FRAME INSTALLATION

STEP 17
ATTACH HORIZONTAL MEMBERS

Note: Before applying any sealant, clean aluminum surfaces using cleaner and method approved by sealant manufacturer.

-Just prior to attaching the horizontal members to the vertical, apply sealant to the front of the shear block as shown.

Horizontals with Concealed Fasteners:

- Slide the horizontal members towards the vertical and attach them to the shear blocks at each end with two FC-1220 fasteners.
- Tool and wipe away any excess sealant at the vertical to horizontal joints.

See **Detail 35**.

CONCEALED FASTENERS

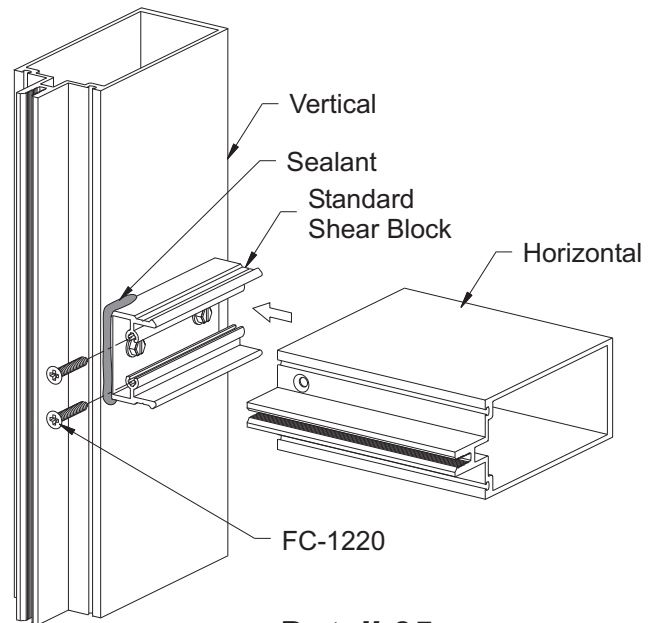

Detail 35

Horizontals with Exposed Fasteners:

- Slide and align the horizontal members towards the vertical and transfer the hole locations on top of the horizontal to the shear block.
- Remove the horizontal and drill a 0.189" dia. (#12 bit) hole at each hole location.
- Slide the horizontal back against the vertical and attach it to the shear block with two FC-1212 fasteners at each end.
- Tool and wipe away any excess sealant at the vertical to horizontal joints.

See **Detail 36**.

EXPOSED FASTENERS

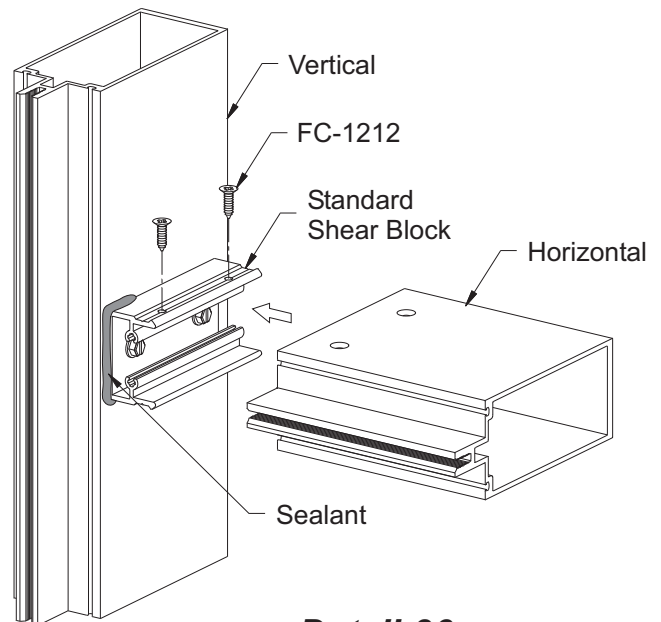

Detail 36

FRAME INSTALLATION

**STEP 17 (Continued)
ATTACH HORIZONTAL MEMBERS**

Open Back Intermediate Horizontals:

- Just prior to attaching the horizontal members to the vertical, apply sealant to the front of the shear block as shown below.
 - Lower the horizontal down onto the shear block. Make sure the horizontal and vertical glazing pockets are flush.
 - Attach the horizontal to the shear block at the face of the horizontal with two FC-1220 fasteners at each end.
 - Tool and wipe away any excess sealant at the vertical to horizontal joints.
 - Snap on the mullion flush filler.
- See **Detail 37**.

OPEN BACK HORIZONTAL

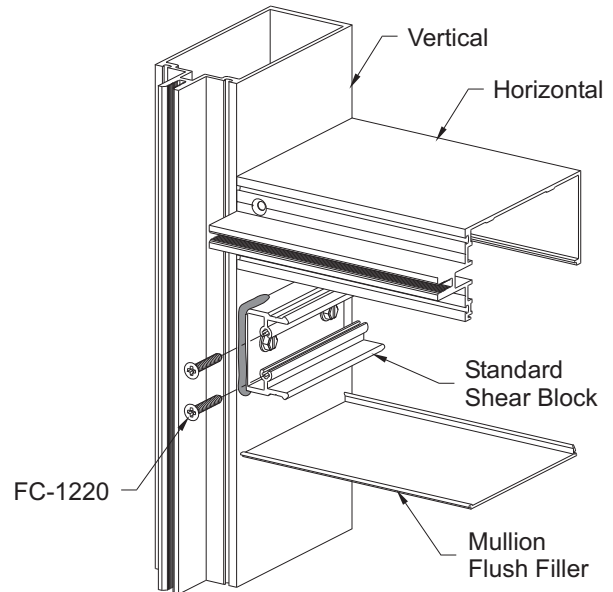

Detail 37

Open Back Head & Sill Members at End Bays:

- To clear the vertical mullions at end bays shear blocks must be pre-attached to the head and sill members through the face of the mullion with FC-1220 fasteners.
 - Position the head/sill members into place and attach the shear blocks to the verticals with two HF-2510-W1 fasteners per block.
 - Provide anchor fasteners per approved shop drawings or engineering calculations.
 - Install the anchor fasteners as recommended by fastener manufacturer.
 - Snap on the mullion flush filler.
- See **Detail 38**.

OPEN BACK HEAD/SILL AT END BAY

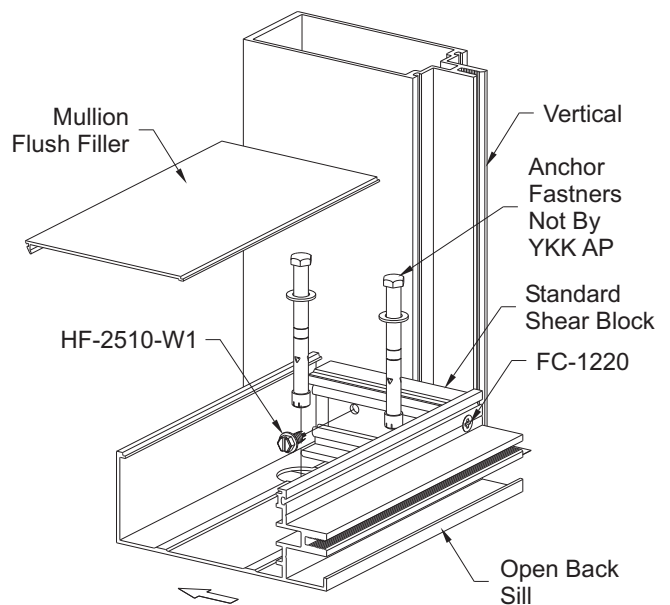

Detail 38

Sill Shown, Head Similar

Caution: A solid shim must be placed under the vertical mullion to transfer glazing dead loads to the foundation.

FRAME INSTALLATION

STEP 17 (Continued)
ATTACH HORIZONTAL MEMBERS

Optional Incidental Water Head Members:

- End anchors must be installed before attaching incidental water heads; install the anchor bolts according to manufacturer’s recommendations.
- Install a weep baffle, E2-0099, directly behind each weep hole. Dab a small amount of sealant on the bottom of the weep baffle to secure it.
- Just prior to installing the the incidental water head members, apply sealant to the underside of the shear clip where it meets the vertical.
- Incidental water head members must be joggled into place:
 - Tilt the head member towards the exterior and engage the back of the head with the back of the shear clip. Rotate the head into place and push it forward to properly seat the head member on the shear clip.
- Attach the head member to the shear clip with two PC-1208 fasteners per clip.
- Apply and tool sealant to the head to vertical intersection at each end as shown in **Detail 40**.
- Snap on the mullion flush filler as shown on **Detail 39**.

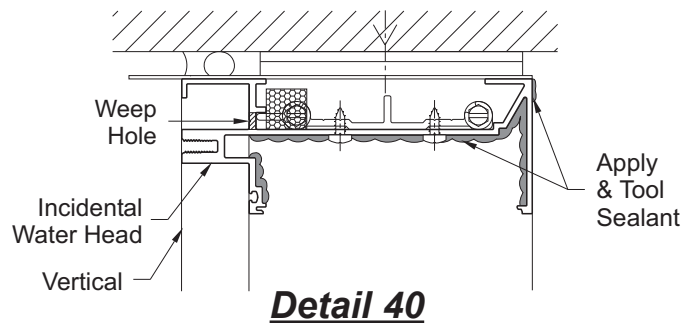
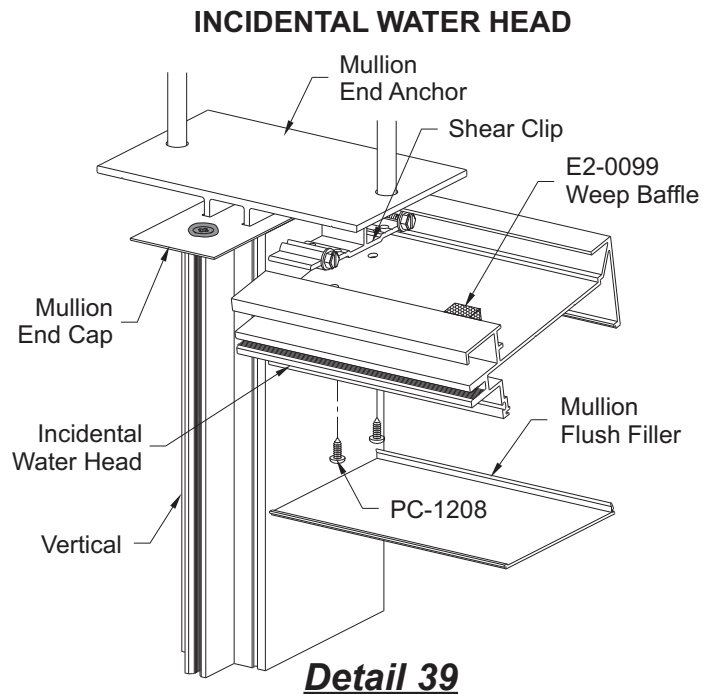

Tubular Head & Sill Members:

- Mullion end anchors must be installed before head and sill members are attached.
- Provide anchor fasteners as per approved shop drawings or engineering calculations.
- Install the anchor fasteners as recommended by fastener manufacturer. See **Detail 41**.
- Clean, seal, and attach head and sill members as previously shown on **Page 35**.

Caution: A solid shim **must** be placed under the vertical mullion to transfer glazing dead loads to the foundation.

TUBULAR HEAD/SILL

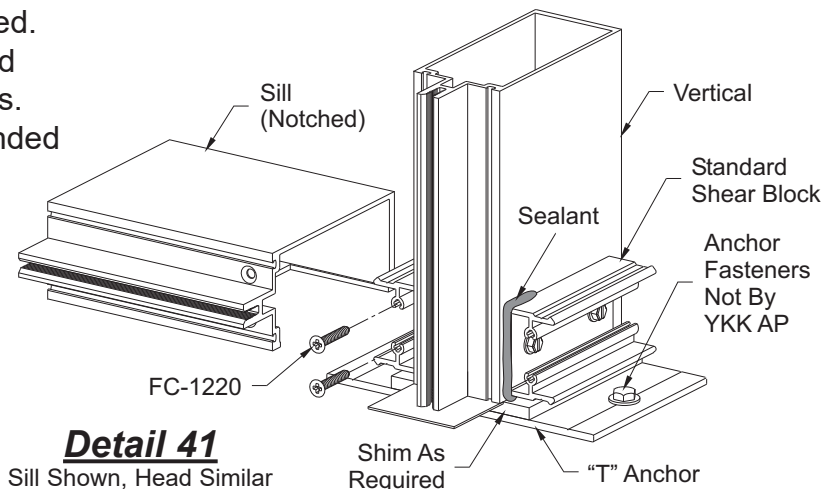

FRAME INSTALLATION

**STEP 17 (Continued)
ATTACH HORIZONTAL MEMBERS**

TUBULAR HORIZONTALS AT END BAYS

For Tubular Horizontals at End Bays (E-Slot):

- Slide the horizontal into place from the interior; the shear blocks should easily pass through the E-Slots at the ends of the horizontal.
- Make sure that the glazing pockets are flush.
- Attach the horizontal to the shear block at each end with FC-1212 fasteners as previously shown for horizontals with exposed fasteners.

See **Detail 42**.

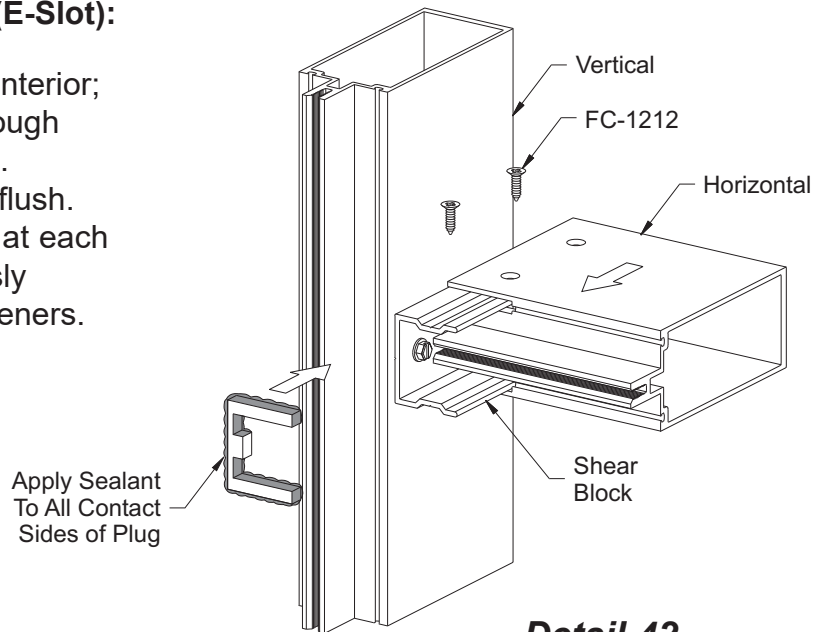

Detail 42

- Apply sealant to all contact sides of the E-Slot plug, E2-0123.
- Insert the E-Slot plug into place and press it firmly against the shear blocks.
- Cover the entire slot with sealant and tool the sealant to ensure a watertight seal.

See **Detail 43**.

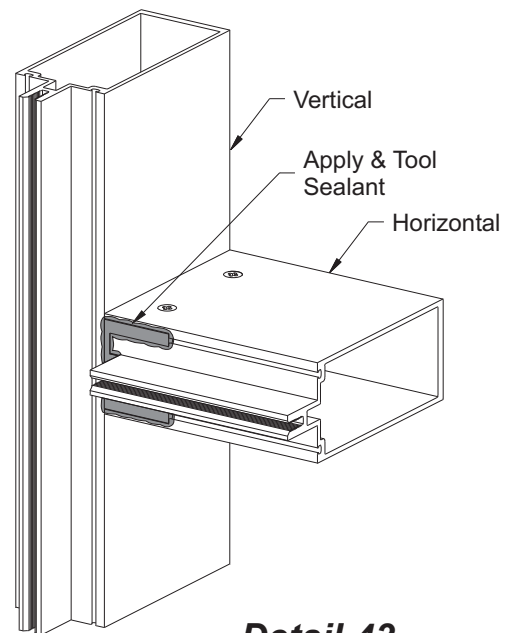

Detail 43

FRAME INSTALLATION

STEP 17 (Continued) ATTACH HORIZONTAL MEMBERS AT CORNER MULLIONS

Note: Before applying any sealant, clean aluminum surfaces using cleaner and method approved by sealant manufacturer.

-Just prior to attaching the horizontal members to the corner mullion, apply sealant to the front of the horizontal at the mitered end as shown in **Detail 44**.

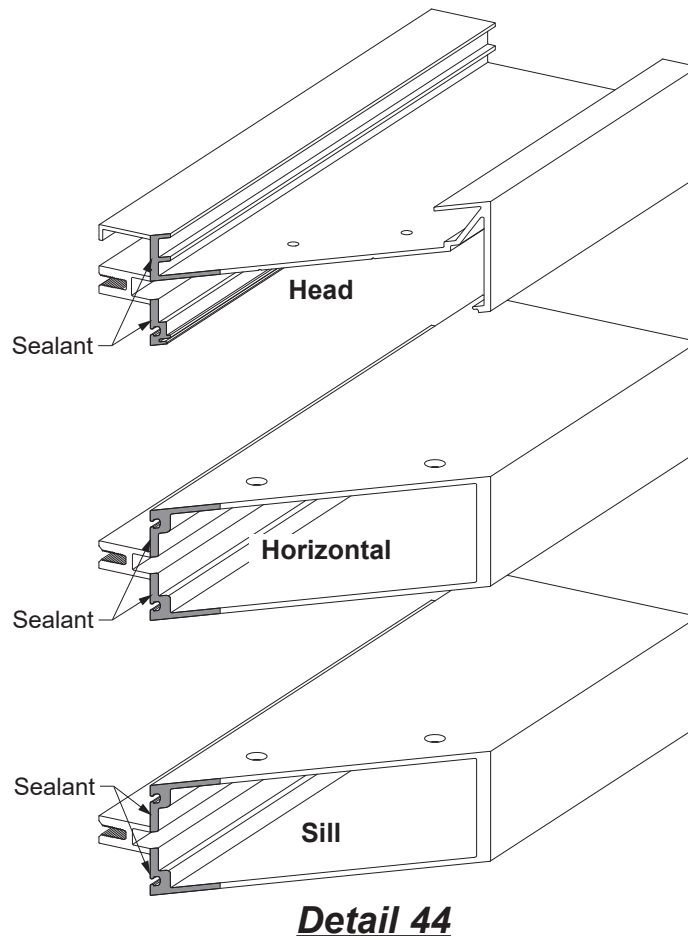

FRAME INSTALLATION

STEP 17 (Continued)

ATTACH HORIZONTAL MEMBERS AT 90° OUTSIDE CORNER MULLIONS

- Just prior to attaching the horizontal members to the corner mullion, apply sealant to the front of the corner shear blocks or shear clips.
- Attach the horizontal members at the mitered end to the corner mullion at the shear blocks with fasteners as shown below in **Detail 45**.
- When using incidental water head members, match drill 0.189” tap holes into the shear clips. Attach the incidental water head using PC-1208 screws.
- Tool and wipe away any excess sealant at the vertical to horizontal joints.

See **Detail 45**.

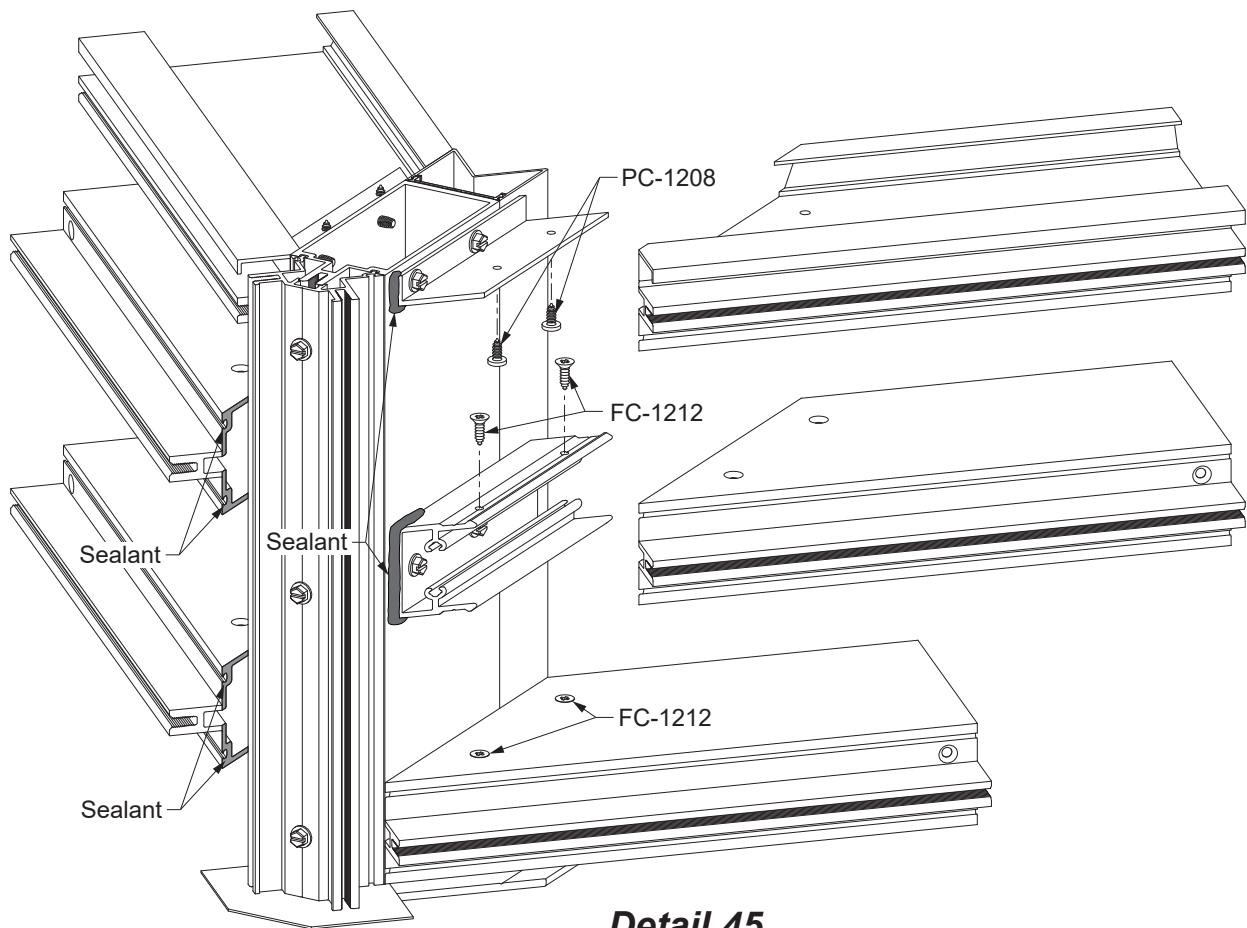

Detail 45

Incidental Water Head Shown,
Tubular Head attachment
Similar to Horiz and Sill

FRAME INSTALLATION

STEP 18 INSTALL DOOR SUBFRAMES

Refer to the **Entrances Installation Manual** for assembly of the door subframes. These subframes are typically glazed into the curtain wall framing at the jambs, and set directly upon the sill substrate without any shims. The subframe members are determined by the approved shop drawings.

-Clean all sealant contact surfaces as recommended by the sealant manufacturer.

-Install the jamb subframe onto the mullion with fasteners according to the approved shop drawings and/or P.E. calculations, setting the subframe jambs in beds of sealant as shown in **Detail 46**.

-Apply and tool sealant to the bottom of the jamb subframe as shown in **Detail 47**.

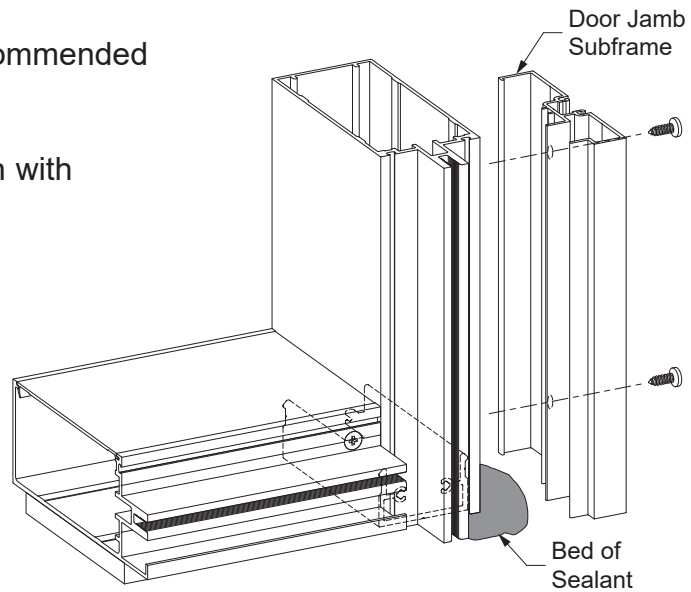

Detail 46

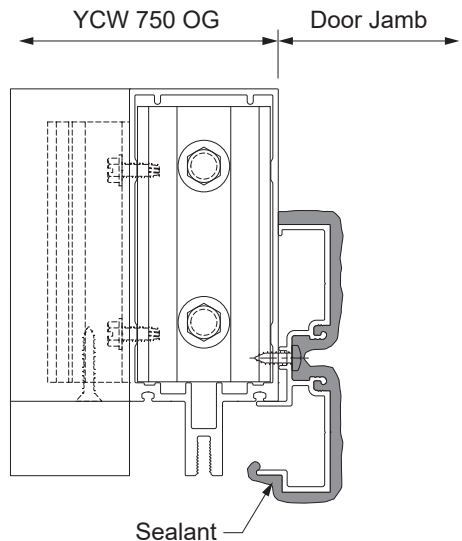

Detail 47

FRAME INSTALLATION

STEP 19a

APPLY PERIMETER SEALANT WHEN USING STANDARD JAMB MEMBERS

- Clean the area around the perimeter of the frame with cleaner and method approved by sealant manufacturer.
- Push in backer rod between the perimeter of the frame and the substrate about 1/4".
- Apply sealant to the perimeter of the frame.
- Tool the sealant to ensure a water tight joint.

See **Detail 48a**.

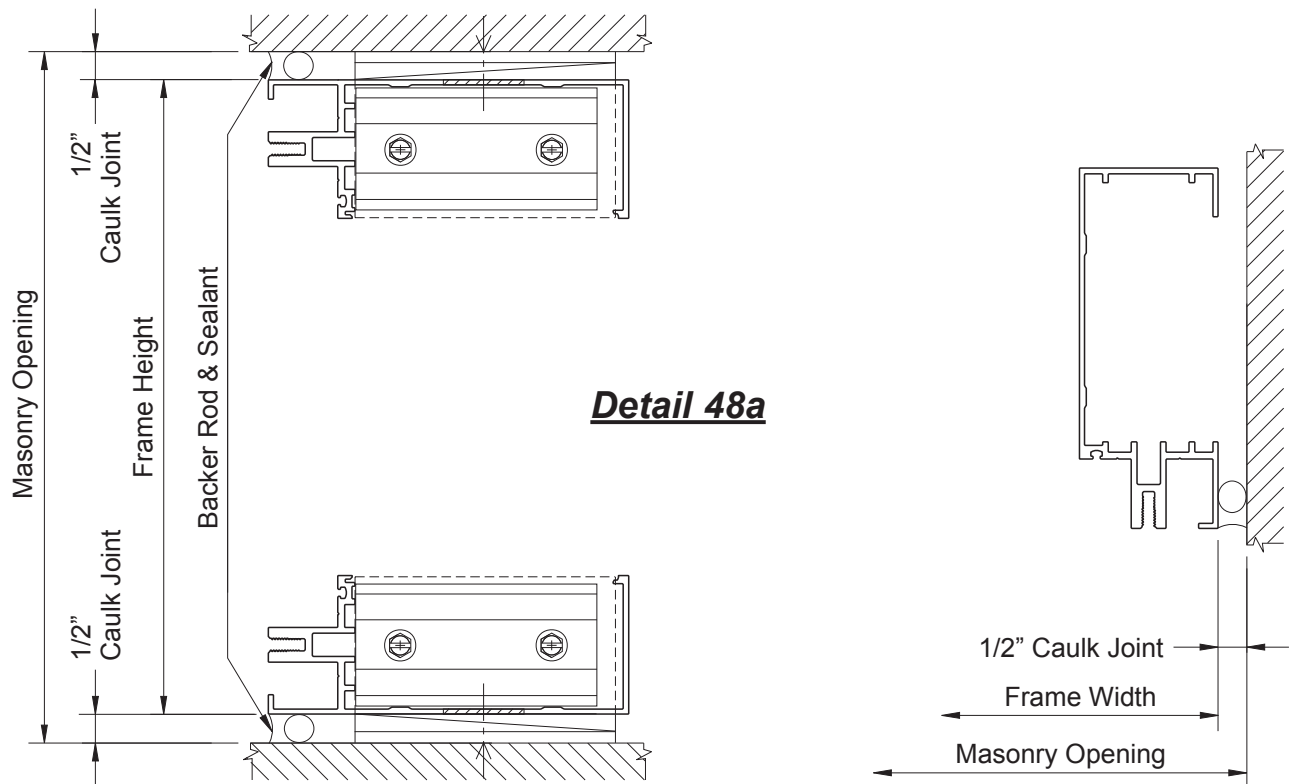

FRAME INSTALLATION

STEP 19b

APPLY PERIMETER SEALANT WHEN USING OPTIONAL JAMB MEMBERS

- Clean the area around the perimeter of the frame with cleaner and method approved by sealant manufacturer.
- Push in backer rod between the perimeter of the frame and the substrate about 1/4".
- Apply sealant to the perimeter of the frame.
- Tool the sealant to ensure a water tight joint.

See **Detail 48b**.

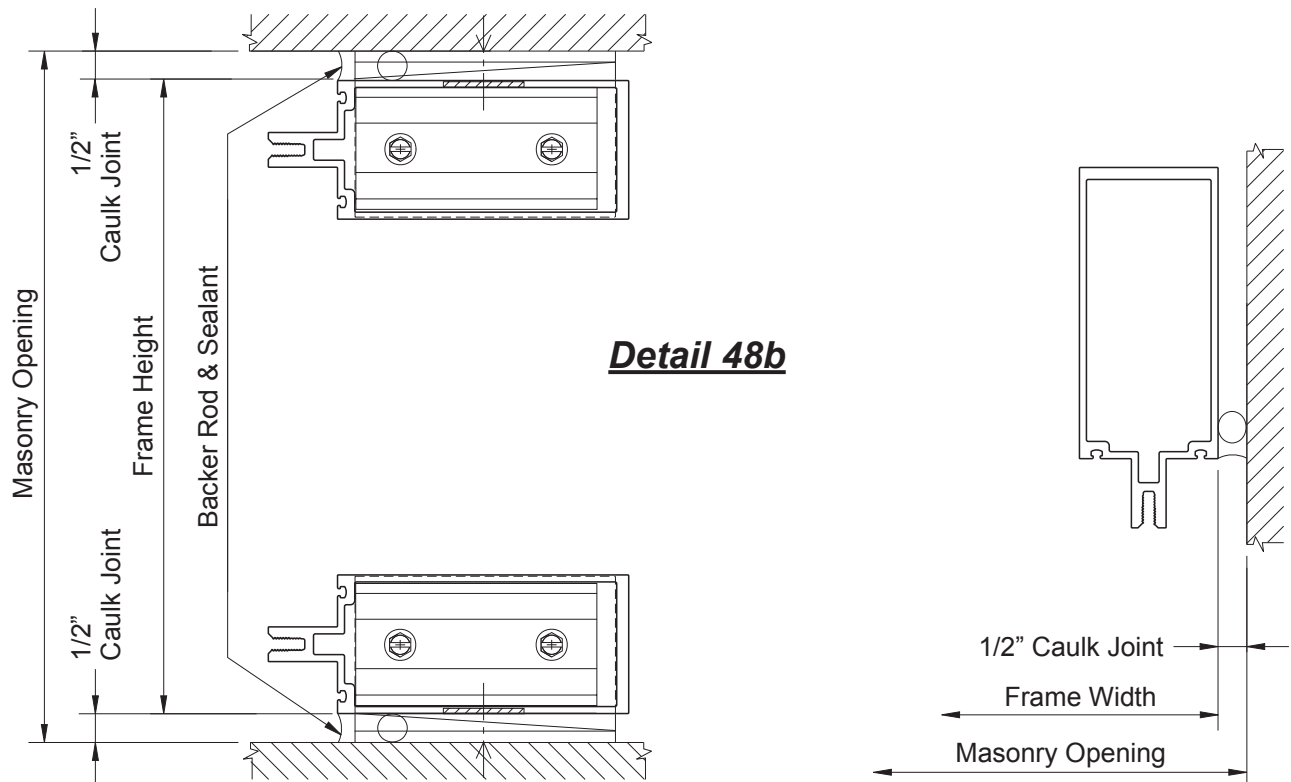

FRAME INSTALLATION

**STEP 20
INSTALL JOINT PLUGS**

The tongue of each head, horizontal and sill must be sealed to the tongue of the vertical and jamb mullions at each end with joint plugs, E2-0102 for 1" glazing or E2-0125 for 1/4" glazing.

For Open Back Sill Members:

- Just prior to installing joint plugs, clean the area around the intersection of the vertical and the sill member with an approved cleaner.
- Apply and tool sealant to the joint where the sill member meets the vertical and along the joint between the mullion end cap and the perimeter leg of the sill member.

See **Detail 49**.

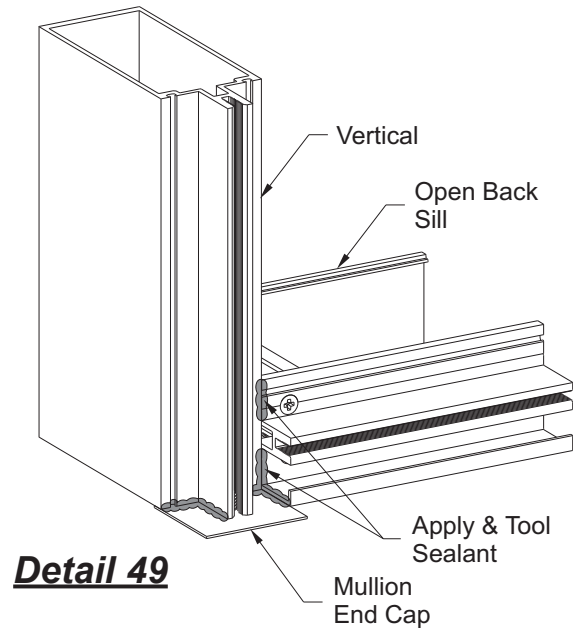

- Clean the area around the mullion tongue ends with an approved cleaner.
- Apply and tool sealant to the joint where the horizontal meets the vertical.
- Apply sealant to the three contact sides of the joint plug.
- Install joint plug as shown with the long leg of the joint plug against the vertical tongue.
- Press the joint plug firmly against the face of the mullion.
- Tool the sealant to ensure a watertight seal.
- Seal all exposed screw heads on the face of the mullion.

See **Detail 50**.

Note: For E-Slot horizontals, E2-0124 joint plug must be used.

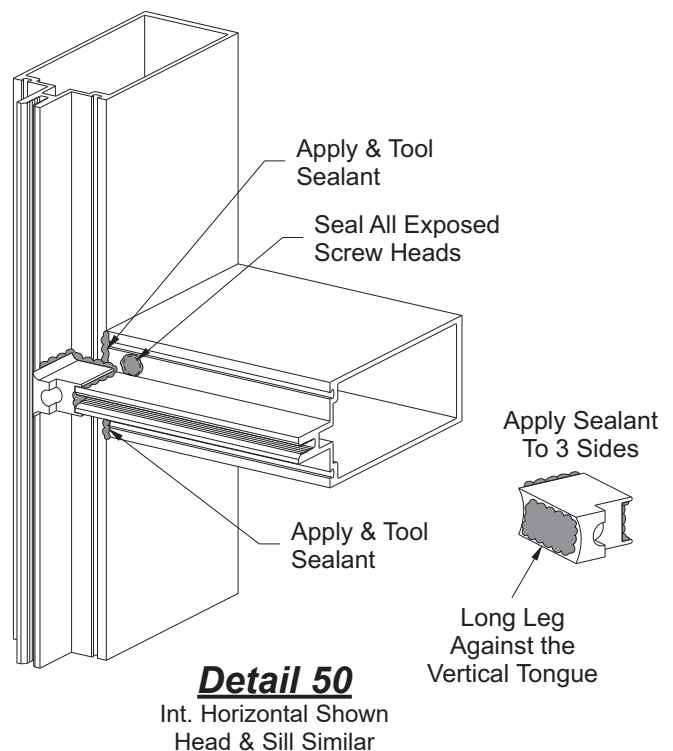

GLAZING

STEP 21 (Optional)
INSTALL GLAZING ADAPTORS

Note: 1/4" glazing adaptor, E9-1220 shown
1/2" glazing adaptor, E9-1232 similar.

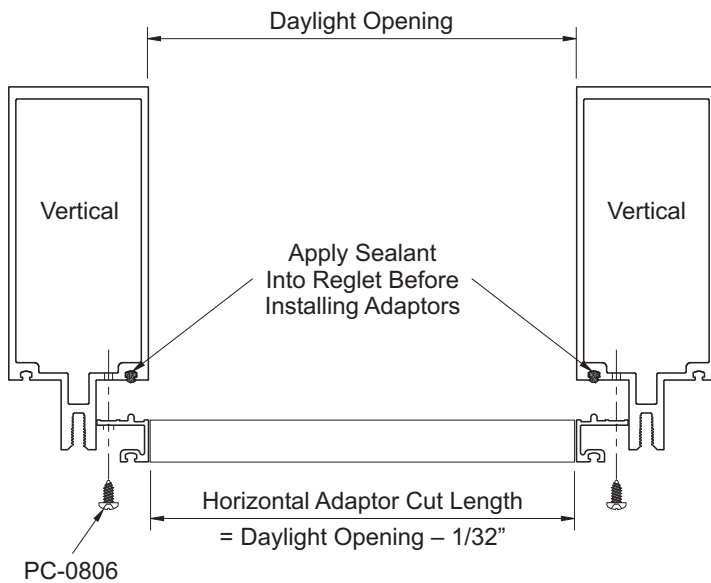

Detail 51

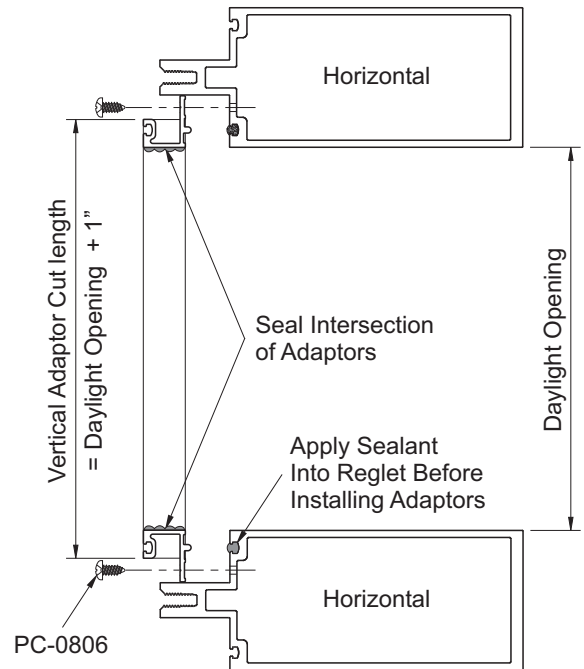

-Cut glazing adaptors to:

Vertical Cut Length = D.L.O. plus(+) 1".

Horizontal Cut Length = D.L.O. minus(-) 1/32".

- Predrill each adaptor along the "V"-groove with 0.189" dia. holes 2" from each end and 24" O.C.
- Dry fit adaptors and match drill 0.141" dia. holes (drill #28) on the mullion to receive PC-0806 fasteners.
- Clean the area around the mullion glazing reglet and the glazing adaptor with a cleaner approved by the sealant manufacturer.
- Apply sealant into the glazing reglet of the mullion and the ends of the horizontal adaptors.
- Install the adaptors with PC-0806 screws at each hole location. Install the vertical adaptors first; make sure they are centered along the day light opening.
- Tool sealant at all adaptor intersections and seal all screw heads.

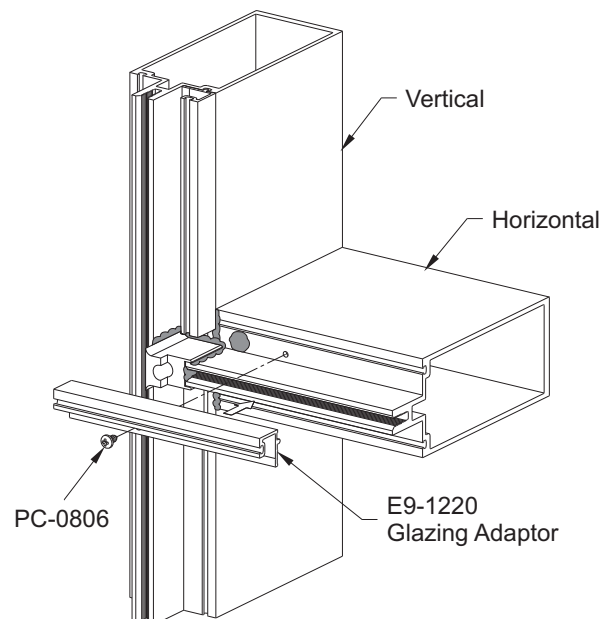

Detail 52

See **Detail 51 & 52.**

GLAZING

**STEP 22
INSTALL INTERIOR GLAZING GASKETS**

- Cut interior glazing gaskets to size:
 Vertical Gasket = Daylight Opening + 1-1/2".
 Horizontal Gasket = Daylight Opening + 1/4" per each foot of opening width.
- Install vertical gaskets first, centered along the daylight opening.
- Install horizontal glazing gaskets next.
 - Insert the glazing gasket into the reglet at each end first.
 - Snap the rest of the glazing gasket into the reglet starting at the center and work towards each end.

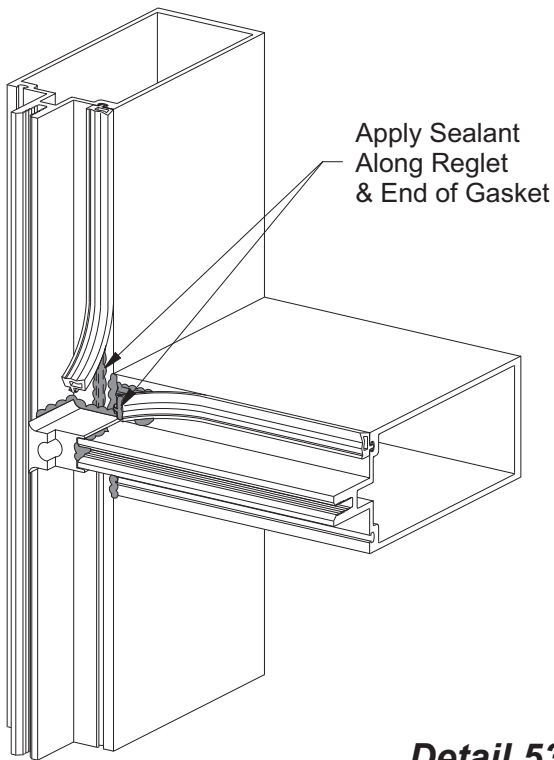

Detail 53

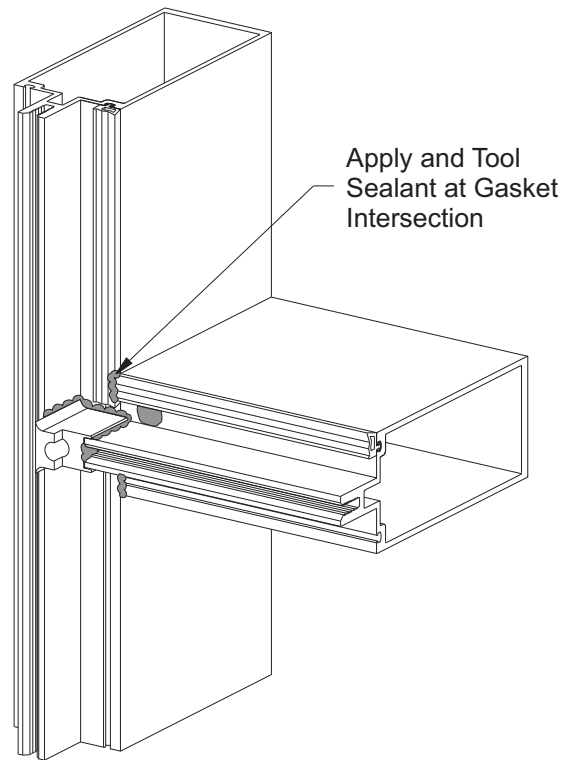

- Pull the last 3" of each gasket away from the reglet.
- With gasket end held out of the way, run a 2-3" bead of sealant into the reglet at the ends.
- Apply sealant at the ends of the horizontal gaskets.
- Reinsert the ends of the gaskets pressing them firmly against the face of the mullions.
- Apply and tool sealant at the intersection of the vertical and horizontal gaskets.

See **Detail 53**.

GLAZING

STEP 23
INSTALL SETTING & SIDE BLOCKS

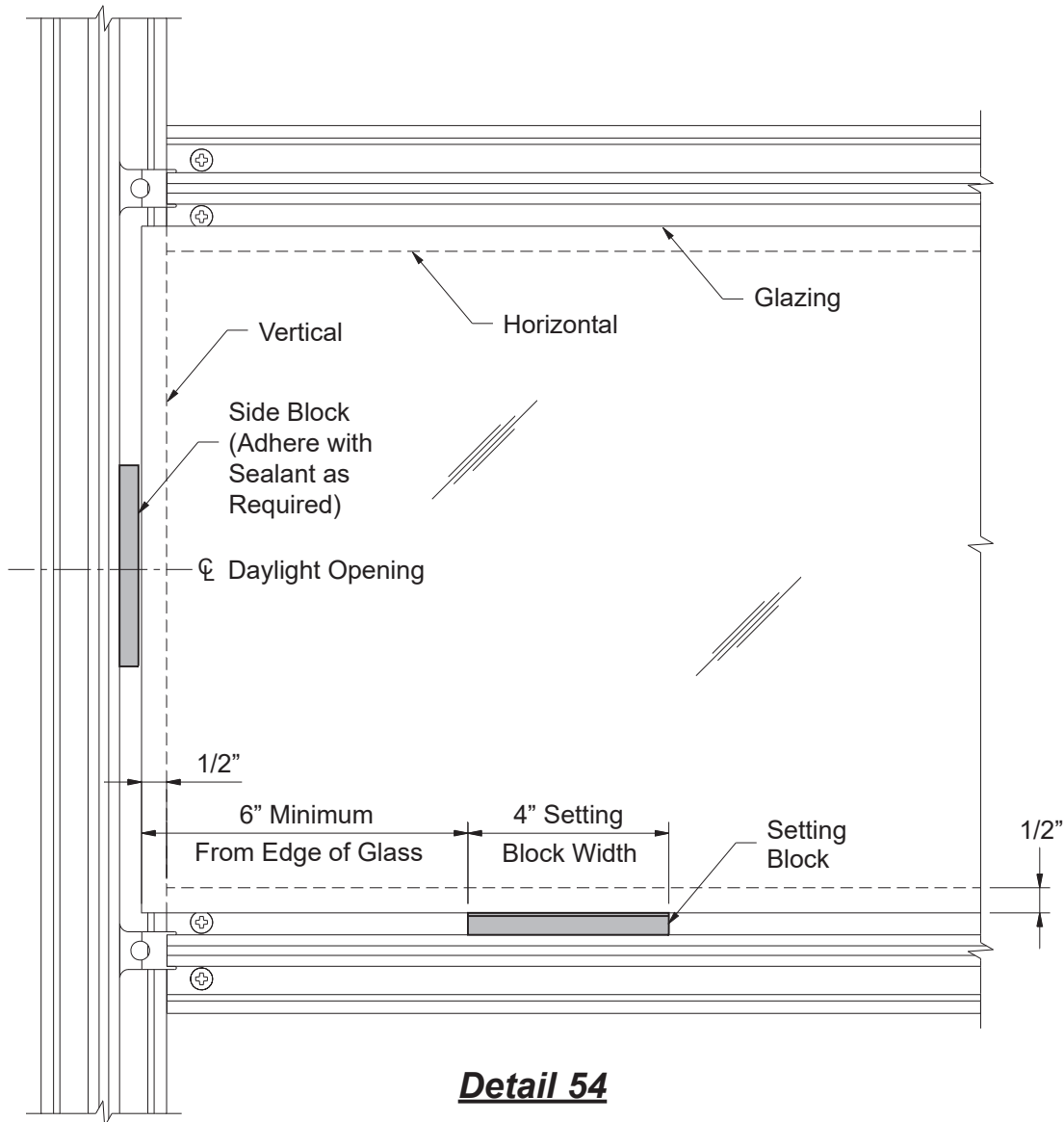

Detail 54

- Install setting blocks, E2-0104 for 1" glazing or E2-0112 for 1/4" glazing, at 1/4 points of D.L.O. or minimum of 6" from edge of glass, whichever is greater. Consult YKK AP for setting block requirements on units that exceed 60" x 90" or 40 sq. ft.
- Install side blocks, E2-0105 (adhere with sealant) for 1" glazing or E2-0113 for 1/4" glazing, centered along the daylight opening on both sides of glazing material.

See **Detail 54**.

GLAZING

**STEP 24
INSTALL EXTERIOR GLAZING GASKETS**

- Preload exterior vertical glazing gaskets to the same length as the vertical pressure plates.
- Preload exterior horizontal glazing gaskets to daylight opening plus 1/4" per foot of opening width.
- Install vertical glazing gaskets onto the vertical pressure plates.
- Install horizontal gaskets by pushing each end into the reglet of the pressure plate. Next, press center of gasket into reglet; then push gasket into reglet working from center towards the ends.

Caution: Do not stretch the gaskets.

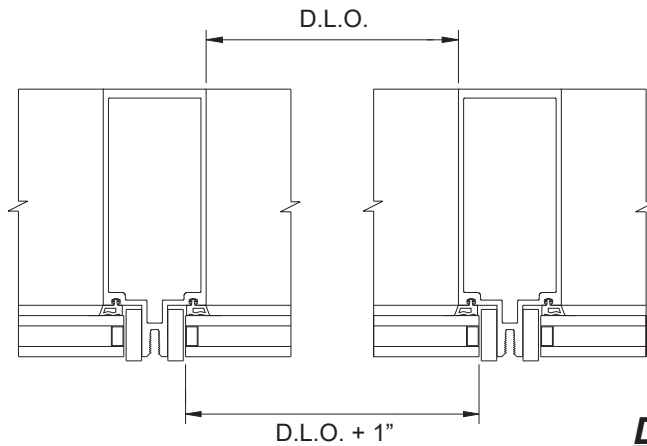

Detail 55

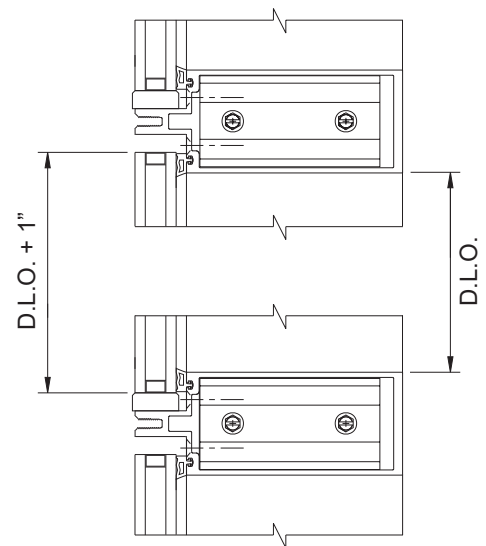

**STEP 25
INSTALL GLASS**

Glass and Spandrel Size = Daylight Opening + 1" Horizontally and Vertically.

- As each lite is installed, attach a temporary retaining clip, E1-1294, in the middle of each horizontal and 4" from glass edge at each end using HD-2516-W3-SS fasteners.
- Reuse the temporary retaining clips.
- Apply sealant to the face of the joint plugs just prior to installing vertical pressure plates. Do not allow sealant to skim over prior to installing pressure plates.

Note: Sealant must form a complete seal between the exterior gasket, pressure plate, thermal isolator, and the joint plug.

See **Detail 55 & 56.**

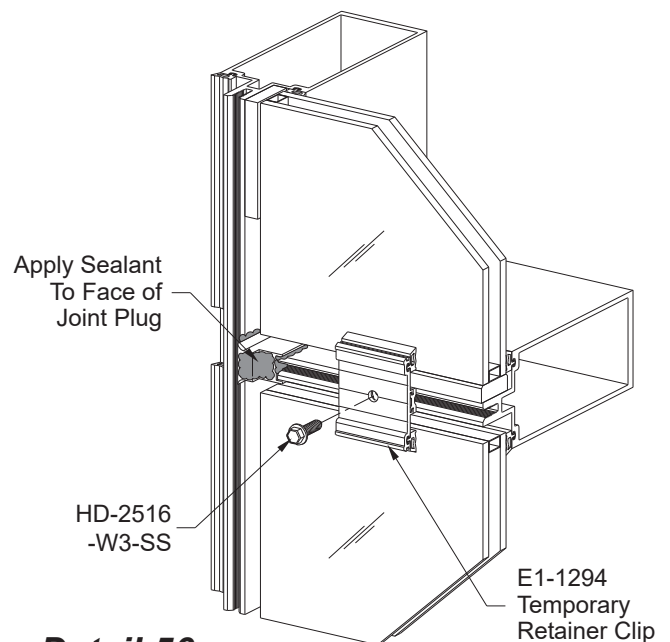

Detail 56

GLAZING

STEP 26
PRESSURE PLATE LAYOUT AND ASSEMBLY

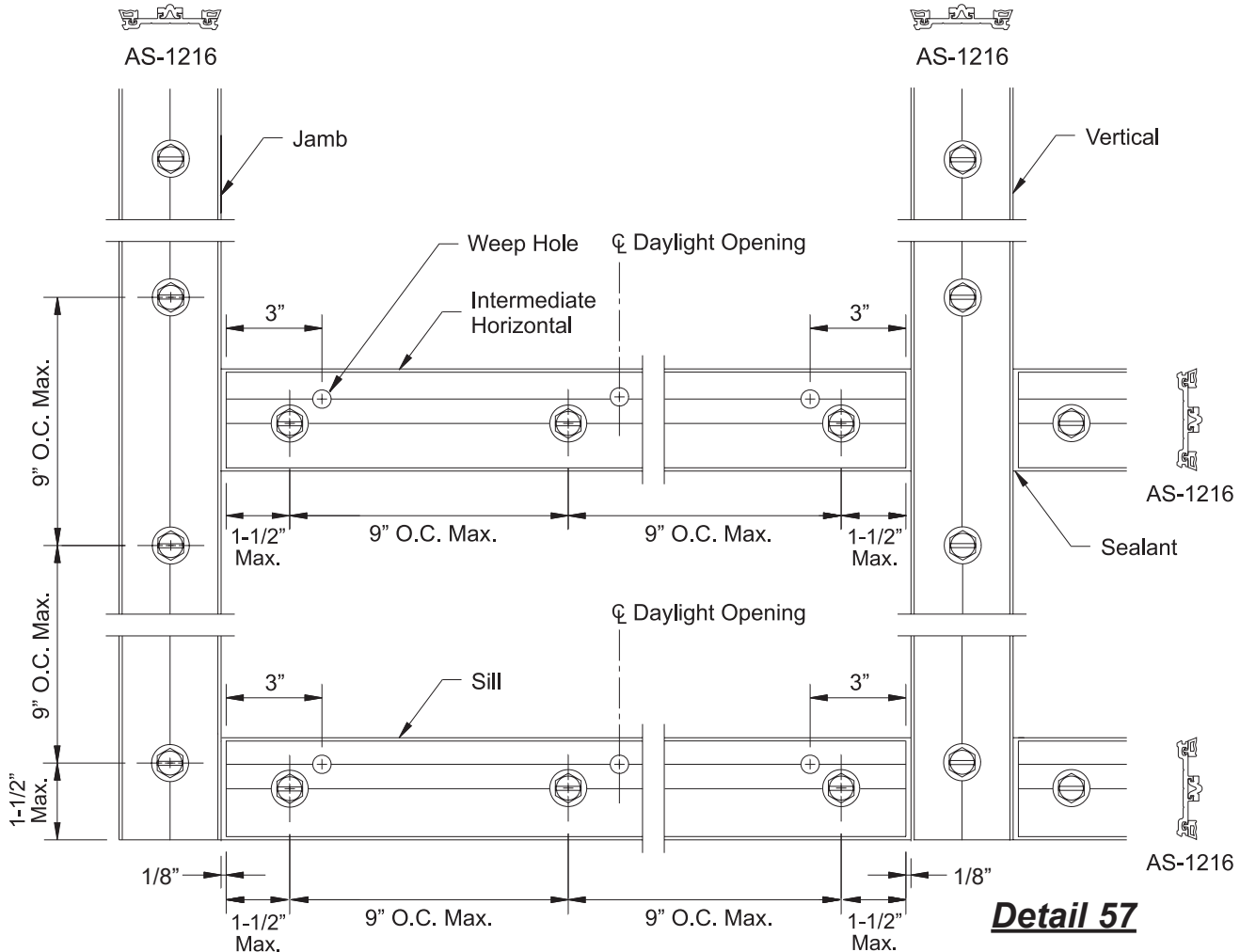

-Pressure plate stock lengths are factory punched with 0.281" diameter holes at 9" O.C. maximum. After cutting, additional holes may be required to have screws 1-1/2" from each end.

See **Detail 57**.

-Install vertical pressure plates using HD-2516-W3-SS screws. Initially torque screws to 30 inch-pounds with a speed wrench or torque limiting screw gun. Work from the bottom up.

-Torque all vertical pressure plate screws to 50 inch-pounds.

-Install vertical face cover E9-1206 using a mallet and a clean piece of lumber. Start at the top of the cover and work block and mallet down the vertical. See **Detail 58**. For installation of deep face covers, see **Step 27A** on **Page 51**.

-Center and install horizontal pressure plates in opening, leaving a 1/8" gap at the ends.

-Starting at the center of each pressure plate, tighten each retainer screw to 50 inch-pounds.

See **Detail 57**.

Note: Perimeter pressure plates AS-3569 (1" glazing) and AS-3572 (1/4" glazing) with isolator tape E2-0239 must be used when using tubular head and sill members.

Mullion end caps must be installed when using mullion end anchors.

GLAZING**STEP 27
INSTALL EXTERIOR FACE COVERS**

- Apply and tool sealant to the gap between horizontal pressure plate and the vertical face cover.
- Install horizontal face cover E9-1206. Start at one end and work block and mallet across the horizontal.

See **Detail 59**.

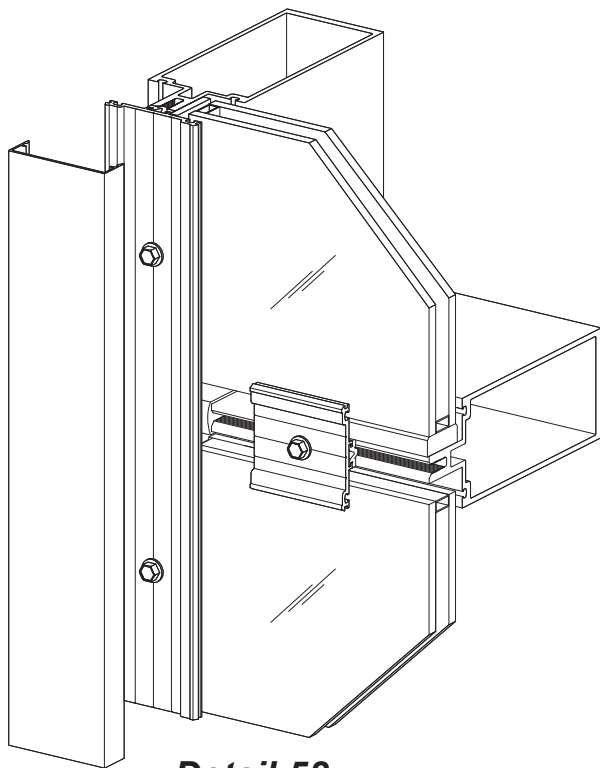

Detail 58

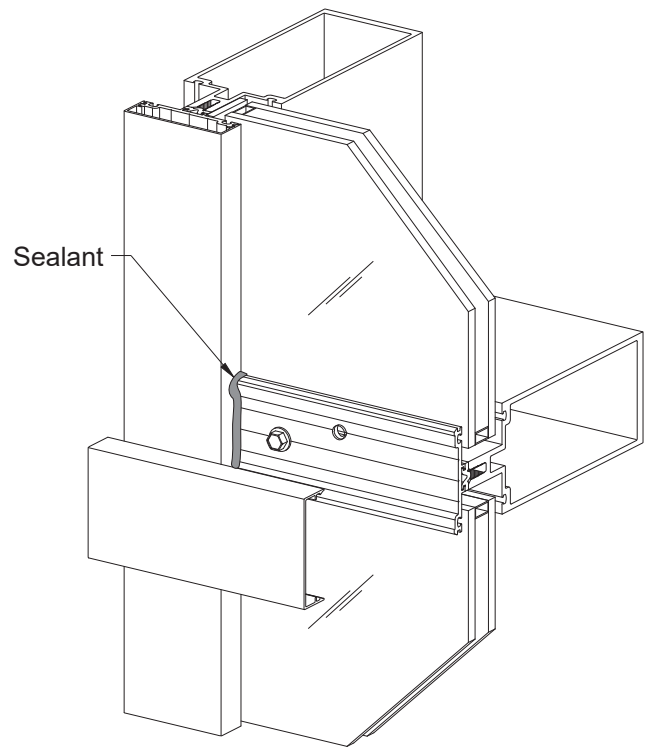

Detail 59

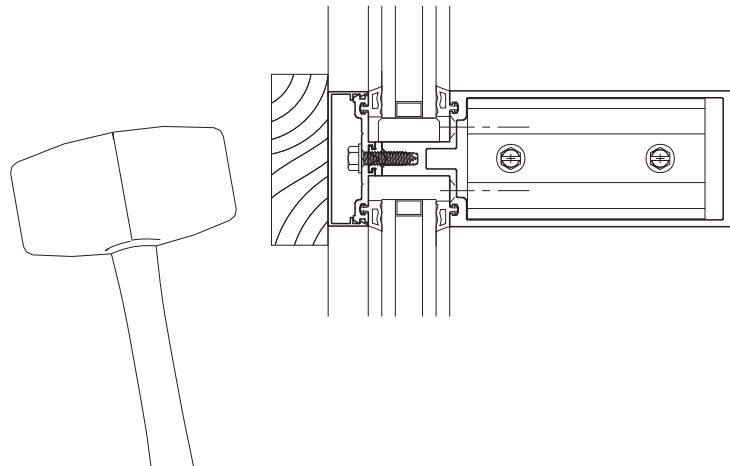

GLAZING

STEP 27A
INSTALL OPTIONAL DEEP FACE COVERS

Installation of a deep vertical cover is similar to that of the standard face cover, except a fastener is required to keep the cover from possibly sliding down over time. Typically, the face cover is fastened with one PC-0808-SS screw at a horizontal to be concealed by the horizontal face cover, unless otherwise specified on the approved shop drawings.

-For concealed fastener locations, drill a 0.189" diameter hole into the side of the face cover, 7/16" from the snap interface of the cover. Snap on the deep cover at its intended location. Using the clear hole as a pilot hole, drill a 0.141" diameter tap hole into the leg on the deep pressure plate. Secure the face cover in place with a PC-0808-SS.

-If the face cover requires it to be fastened at an exposed location, drill a 0.189" diameter countersunk hole into the side of the cover. Snap on the deep cover at its intended location. Using the clear hole as a pilot hole, drill a 0.141" diameter tap hole into the leg on the deep pressure plate. Secure the face cover in place with an FC-0808-SS screw.

-Continue to install the horizontal pressure plate and face cover as specified on **Pages 49 & 50**.

See **Detail 60**.

Installation of horizontal deep face covers is similar except the screw is always on the top of the face cover with its head set in sealant.

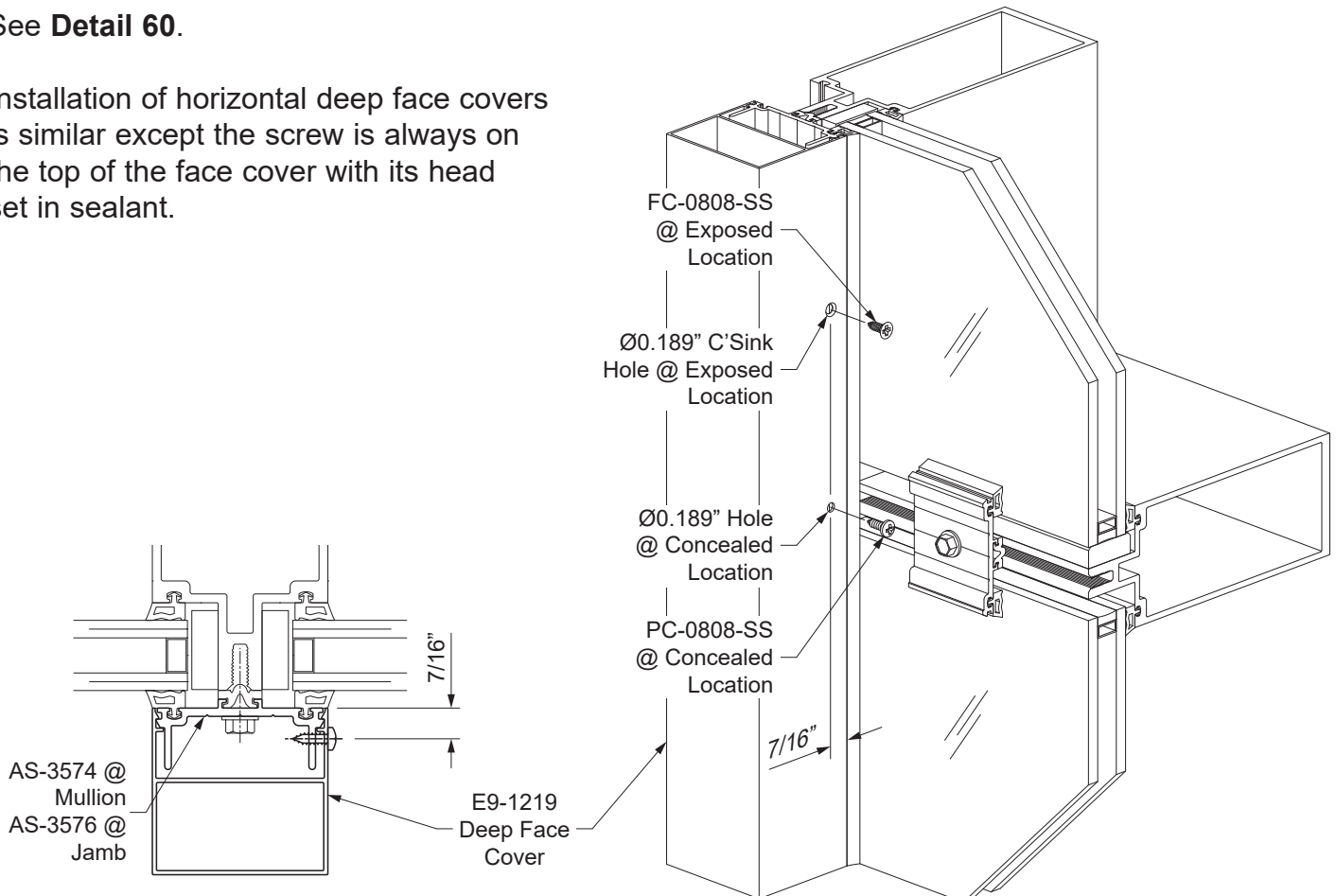

Detail 60

 **YKK AP America Inc.**

101 Marietta Street NW

Suite 2100

Atlanta, Georgia 30303

www.ykkap.com