

**YWW 50 T Thermal Window Wall System
Continuous Head & Sill
SSG**

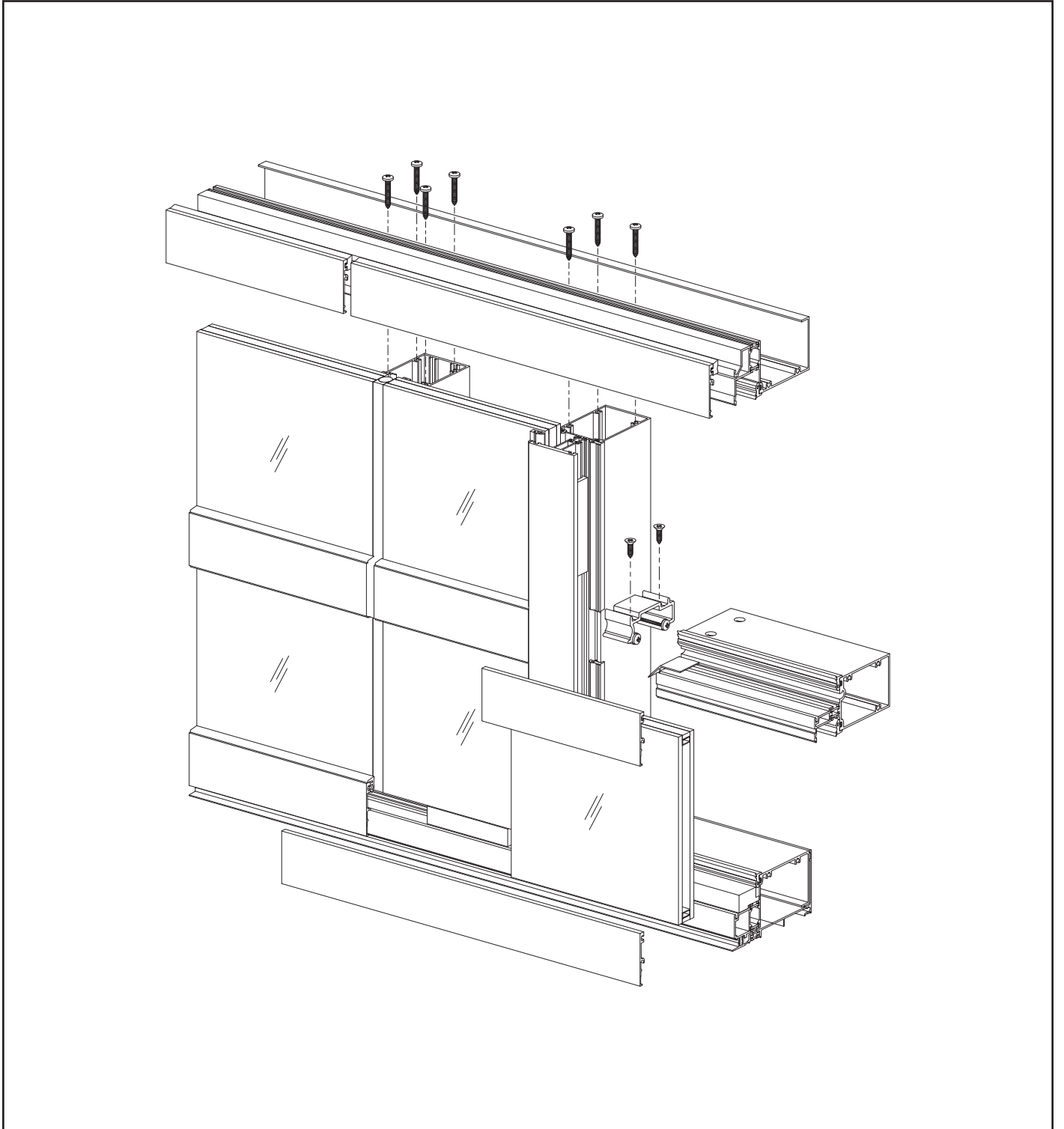

Installation Manual

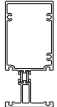

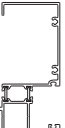



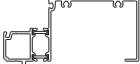













TABLE OF CONTENTS

Installation Notes	Page ii
PARTS DESCRIPTION	
Framing Members	Pages 1 to 4
Accessories	Pages 5 to 7
FRAME FABRICATION	
Determine Frame Size	Pages 8 & 9
Fabricate Sill Flashing	Page 10
Fabricate Head & Sill Members	Pages 11 & 12
Fabricate Two Piece Verticals & Jamb Members	Pages 13 & 14
Fabricate Interior & Exterior Glass Stops	Pages 16 & 17
Fabricate Glazing Adaptors	Page 18
Fabricate Plate Adaptors	Page 19
Fabricate Head Receptor & Slab Edge Cover	Page 20
Fabricate Head Near Expansion Joint	Page 21
FRAME ASSEMBLY	
Attach Mullion End Caps	Page 22
Install End Dams	Page 22
Prepare Frames for Assembly	Page 23
Assemble Frames	Page 23
Assemble Sill Flashing for Slab Edge Cover	Page 24
Assemble Head Receptor for Slab Edge Cover	Pages 25 & 26
Assemble Slab Edge Cover Plates	Page 26
FRAME INSTALLATION	
Install Sill Flashing	Page 27 to 28
Sill Preparation	Page 28
Install Corner Mullions for Vertical Through Frames	Page 29 & 30
Assemble and Install Head Receptor	Pages 31 & 32
Install Slab Edge Cover	Page 33
Install Slab Sill Flashing for Slab Edge Cover	Pages 34 & 35
Install Assembled Frames	Pages 36
Apply Internal & Perimeter Sealant	Page 37
Install Slab Edge Frames	Pages 38 & 39
Apply Perimeter Sealant at Slab Edge Locations	Pages 40 & 41
Install Water Deflectors & Horizontal Bridges	Page 42 to 44
Install Corner Trim Base and Cover	Page 44 & 45
Install 1/4" Glazing Adaptors	Page 46
GLAZING	
Seal Inside Glazed Horizontals	Page 47
Install Glazing Gaskets	Page 48
Install Glass for Standard Glazing	Pages 49 to 51
Install Glass for Structural Silicone Glazing	Pages 52 to 56









Installation Notes

1. Do not drop, roll or drag boxes of aluminum framing. Move and stack boxes with proper support to prevent distortion. If fork lifts are used be especially careful about striking the boxes when lifting or moving.
2. Store in a dry, out of the way area. If rain exposure, condensation or any water contact is likely, then all packaging material should be removed. Wet packaging materials will discolor and may stain aluminum finishes and paints.
3. All materials should be checked for quantity and quality upon receipt, YKK AP must be notified immediately of any discrepancies in shipment. Check to make sure that you have the required shims, sealants, supplies and tools necessary for the installation.
4. Carefully check the openings and surrounding conditions that will receive your material. Remember, if the construction is not per the construction documents, it is your responsibility to notify the general contractor in writing. Any discrepancies must be brought to the general contractor's attention before you proceed with the installation.
5. Gather your shop drawings, materials, packing list and this installation manual. Carefully review parts location, the sequence it goes therein when you glaze it and how you seal it. Installation instructions are of a general nature and may not cover every condition you encounter. The shop drawings and/or installation manuals were prepared specifically for the product.
6. Any material substitutions must be of equal or greater quality.
7. Make certain that material samples have been sent for compatibility testing for all manufacturer's sealants involved. Make certain that sealants have been installed in strict accordance with the manufacturer's recommendations and specifications.
8. Remember to isolate, in an approved manner, all aluminum from uncured masonry or other incompatible materials.
9. System-to-structure fasteners are not supplied by YKK AP. Fasteners called out on shop drawings are to indicate minimum sizes for design loading.
10. Entrances are to be installed plumb, square, level and true.
11. If any questions arise concerning YKK AP products or their installation, contact YKK AP for clarification before proceeding.
12. YKK AP store front and/or curtain wall framing is typically completed before drywall, flooring and other products that may still be in process. Take the extra time to wrap and protect the work produced.
13. Cutting tolerances are plus zero, minus one thirty second unless otherwise noted.
14. Check our website, www.ykkap.com, for the latest installation manual update prior to commencing work.

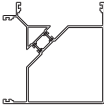

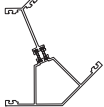











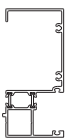

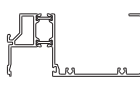
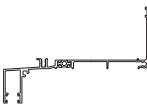
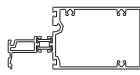
FRAMING MEMBERS FOR OUTSIDE GLAZING

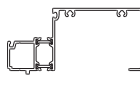
 <p>Vertical For Continuous Head & Sill Construction</p>	<p>BE9-2803</p>	 <p>Aluminum Plate Adaptor Use with BE9-2814</p>	<p>E9-8222</p>
 <p>Head / Jamb</p>	<p>BE9-2816</p>	 <p>Head Receptor</p>	<p>BE9-2819</p>
 <p>Horizontal</p>	<p>BE9-8728</p>	 <p>Snap Cover Use with BE9-2819</p>	<p>E9-8720</p>
 <p>Sill</p>	<p>BE9-2823</p>	 <p>Pocket Filler</p>	<p>BE9-8734</p>
 <p>Exterior Glass Stop Use with BE9-2823 & BE9-8728</p>	<p>E9-1715</p>	 <p>Glazing Adaptor For 1/4" glazing Use with BE9-8734</p>	<p>E9-1725</p>
 <p>Deep Pocket Glazing Adaptor For 1/4" Glazing</p>	<p>E9-1707</p>	 <p>6-1/8" Slab Edge Cover For use with 5-1/8" Slab</p>	<p>E9-8059</p>
 <p>Shallow Pocket Glazing Adaptor For 1/4" Glazing</p>	<p>E9-1708</p>	 <p>6-5/8" Slab Edge Cover For use with 5-5/8" Slab</p>	<p>E9-7723</p>
 <p>Sill Flashing</p>	<p>BE9-2818</p>	 <p>7-3/8" Slab Edge Cover For use with 6-3/8" Slab</p>	<p>E9-8223</p>
 <p>Sill Flashing With Integral Plate Adaptor</p>	<p>BE9-2812</p>	 <p>7-7/8" Slab Edge Cover For use with 6-7/8" Slab</p>	<p>E9-8231</p>
 <p>Sill Flashing</p>	<p>BE9-2814</p>	 <p>8" Slab Edge Cover For use with 7" Slab</p>	<p>E9-8589</p>

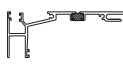







FRAMING MEMBERS FOR OUTSIDE GLAZING

	<p>9" Slab Edge Cover For use with 8" Slab</p>	<p>E9-8428</p>		<p>Expansion Mullion Male</p> <p>BE9-2827</p>
	<p>90° Corner Mullion Use with (2) BE9-8734</p>	<p>BE9-8731</p>		<p>Slip-On Face Cap Use with BE9-2827</p> <p>E9-1763</p>
	<p>135° Outside Corner Mullion Use with (2) BE9-8734</p>	<p>BE9-8725</p>		<p>Hinged Mullion Female</p> <p>BE9-7912</p>
	<p>Expansion Mullion Female Elastomer Weathering E2-0065 not Included</p>	<p>BE9-8708</p>		<p>Outside Hinged Mullion Male 3° to 20°</p> <p>BE9-7911</p>







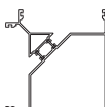

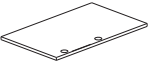
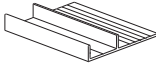
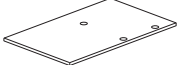
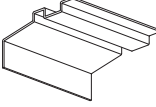
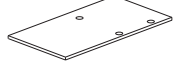
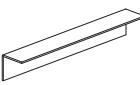

FRAMING MEMBERS FOR STRUCTURAL SILICONE GLAZING

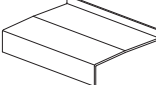
 <p>Vertical For Structural Silicone Glazing</p>	<p>E9-2805</p>	 <p>SSG Expansion Mullion Female</p>	<p>E9-2824</p>
 <p>Glazing Adaptor For 1/4" Glazing Use with E9-2805</p>	<p>E9-2716</p>	 <p>SSG Expansion Mullion Male</p>	<p>E9-2825</p>
 <p>Head / Jamb / Sill</p>	<p>BE9-2816</p>	 <p>Sill Flashing</p>	<p>BE9-2818</p>
 <p>Head For Spliced Runs Longer than 24'-0"</p>	<p>BE9-2801</p>	 <p>Sill Flashing With Integral Plate Adaptor</p>	<p>BE9-2812</p>
 <p>Horizontal</p>	<p>BE9-8728</p>	 <p>Sill Flashing</p>	<p>BE9-2814</p>
 <p>Sill For Spliced Runs Longer than 24'-0"</p>	<p>BE9-2823</p>	 <p>Aluminum Plate Adaptor Use with BE9-2814</p>	<p>E9-8222</p>
 <p>Exterior Glass Stop Use with BE9-8728 & BE9-8706</p>	<p>E9-1715</p>	 <p>Head Receptor</p>	<p>BE9-2819</p>
 <p>Exterior Glass Stop Use with BE9-2801</p>	<p>E9-1730</p>	 <p>Snap Cover Use with BE9-2819</p>	<p>E9-8720</p>
 <p>Deep Pocket Glazing Adaptor For 1/4" Glazing</p>	<p>E9-1707</p>	 <p>Pocket Filler</p>	<p>BE9-8734</p>
 <p>Glazing Adaptor For 1/4" Glazing</p>	<p>E9-1708</p>	 <p>Glazing Adapter For 1/4" glazing Use with BE9-8734</p>	<p>E9-1725</p>



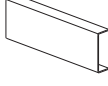

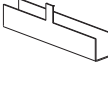
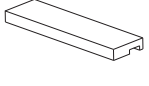
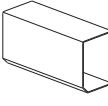
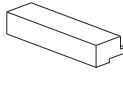

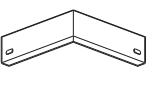
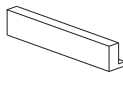















FRAMING MEMBERS FOR STRUCTURAL SILICONE GLAZING

 <p>6-1/8" Slab Edge Cover For use with 5-1/8" Slab</p>	<p>E9-8059</p>	 <p>9" Slab Edge Cover For use with 8" Slab</p>	<p>E9-8428</p>
 <p>6-5/8" Slab Edge Cover For use with 5-5/8" Slab</p>	<p>E9-7723</p>	 <p>90° Corner Mullion For structural silicone glazing</p>	<p>E9-2821</p>
 <p>7-3/8" Slab Edge Cover For use with 6-3/8" Slab</p>	<p>E9-8223</p>	 <p>90° Outside Corner Trim Base For 1" Glazing</p>	<p>E9-2550</p>
 <p>7-7/8" Slab Edge Cover For use with 6-7/8" Slab</p>	<p>E9-8231</p>	 <p>90° Outside Corner Trim Cover</p>	<p>E9-3439</p>
 <p>8" Slab Edge Cover For use with 7" Slab</p>	<p>E9-8589</p>	 <p>90° Corner Mullion Use with (2) BE9-8734</p>	<p>BE9-8731</p>



















ACCESSORIES

 <p>Shear Block For BE9-8728 Horizontal Use (2) PC-1228 & (2) FC-1212 not Included</p>	E1-2802	 <p>SSG Mullion End Cap</p>	E1-2805
 <p>"F" Anchor For Head & Jamb</p>	E1-2803	 <p>Expansion Mullion End Cap</p>	E1-2806
 <p>Splice Sleeve For Head Receptor</p>	E1-2813	 <p>Standard Mullion End Cap</p>	E1-2809
 <p>Splice Sleeve For Head Receptor</p>	E1-9962	 <p>End Cap For BE9-2812 Sill Flashing</p>	E1-9951
 <p>Splice Sleeve For Sill Flashing at Slab Edge Cover</p>	E1-9959	 <p>End Cap For E9-8222 Adaptor</p>	E1-1196
 <p>Splice Sleeve For Sill Flashing and Head Receptor</p>	E2-0070	 <p>End Cap For Head Receptor at Jamb</p>	E1-9952
 <p>Joint Sleeve For Head & Sill (Forward Chamber)</p>	E1-1027	 <p>End Cap For Head Receptor at Splice Joint</p>	E1-9957
 <p>Joint Sleeve For SSG Head & Sill (Forward Chamber)</p>	E1-1028	 <p>Setting Block / Side Block 1" Glazing</p>	E2-0184
 <p>Joint Sleeve For Head & Sill (Rear Chamber)</p>	E1-2804	 <p>Setting Block For Sill 1" Glazing</p>	E2-0182
 <p>Water Deflector For Horizontals at Structural Silicone Glazed Verticals</p>	E1-1038	 <p>Setting Block For Horizontal 1/4" Glazing</p>	E2-0192
 <p>Water Deflector For Horizontals at 90° Structural Silicone Glazed Corners</p>	E1-1039	 <p>Setting Block For Sill 1/4" Glazing</p>	E2-0190

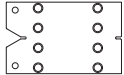
ACCESSORIES

	Setting Block Use with BE9-2819	E2-0054		Temporary Glass Retainer For 1/4" Structural Silicone Glazing	E3-0006
	Weep Baffle	E2-0098		Temporary Glass Retainer For 90° Outside SSG Corner	E1-3588
	Weep Baffle	E2-0099		End Cap Use with E9-8059	E1-9984
	Side Block	E2-0186		End Cap Use with E9-7723	E1-9985
	Side Block	E2-0537		End Cap Use with E9-8223	E1-9953
	Anti-Walk Block For Deep Pocket	E2-0153		End Cap Use with E9-8231	E1-9954
	Anti-Walk Block	E2-0546		End Cap Use with E9-8589	E1-9955
	Water Deflector	E2-0047		End Cap Use with E9-8428	E1-9956
	End Dam For Frame Ends Where Head & Sill Run Through	E2-0193		Push-In Glazing Gasket	E2-0801
	End Dam For Frame Ends Where Head & Sill Run Through	E2-0194		Wedge Glazing Gasket	E2-0808
	Temporary Glass Retainer For 1" Structural Silicone Glazing	E3-0001		Push-In Glazing Gasket For SSG Glazing	E2-0541

ACCESSORIES

	<p>Wedge Glazing Gasket For SSG Glazing</p>	<p>E2-0542</p>	 <p>#1/4\"-20 x 1\" HWHMS Zinc Plated Steel For Attachment Corner Temp Glass Retainer</p>	<p>HM-2516</p>
	<p>SSG Glazing Spacer For Inside Glazing</p>	<p>E2-0543</p>	 <p>#10 x 3/8\" PHSMS-SS Type AB, Stainless Steel For Attachment of Head Receptor Splice</p>	<p>PC-1006 -SS</p>
	<p>SSG Glazing Spacer For Outside Glazing</p>	<p>E2-0544</p>	 <p>#10 x 5/8\" PHSMS Type AB Zinc Plated Steel For Attachment of E9-1724 Adaptor</p>	<p>PC-1010</p>
	<p>Weathering Gasket For Expansion Mullion</p>	<p>E2-0065</p>	 <p>#12 x 3/4\" FHSMS Type AB Zinc Plated Steel For Attachment of Horizontal to Shear Block E1-1037</p>	<p>FC-1212</p>
	<p>Airtight Gasket For Head Receptor</p>	<p>E2-0051</p>	 <p>#12 x 5/8\" PHSMS Type AB Zinc Plated Steel, For Attachment of Shear Clip E1-1040 to Vertical & Horiz.</p>	<p>PC-1210</p>
	<p>Steel Reinforcing 3/16\" x 2-3/4\" Use with E9-8443, E9-2805</p>	<p>E1-2811</p>	 <p>#12 x 1\" PHSMS Type AB Zinc Plated Steel For Screw Spline Attachment</p>	<p>PC-1216</p>
	<p>Drill Fixture</p>	<p>H-7250</p>	 <p>#12 x 1-1/4\" PHSMS Type AB Zinc Plated Steel, For Screw Spline Attachment When Using BE9-1704 as Jamb</p>	<p>PC-1220</p>
	<p>#8 x 1/2\" FHSMS Type AB Zinc Plated Steel For Attachment of Hinged Mullions</p>	<p>FC-0808</p>	 <p>#12 x 1-3/4\" PHSMS Type AB, Zinc Plated Steel For Attachment of Shear Block E1-2802 to Vertical</p>	<p>PC-1228</p>
	<p>#10 x 3/8\" FHSMS Type AB Zinc Plated Steel For Attachment of Mullion End Caps</p>	<p>FC-1006</p>	 <p>#10 x 3/8\" PHMS Stainless Steel, For Attachment of Sill Flashing</p>	<p>PM-1006 -SS</p>
	<p>#12 x 3/4\" UFHSMS Type A, Zinc Plated Steel, For End Dam Attachment</p>	<p>UA-1212</p>		

FRAME FABRICATION

STEP 1 DETERMINE FRAME SIZE

Determine Frame Width:

Note: Check the opening for squareness and plumb at both ends. Units must be installed in a true rectangle.

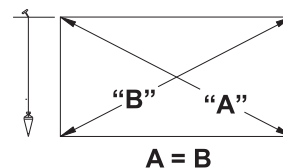
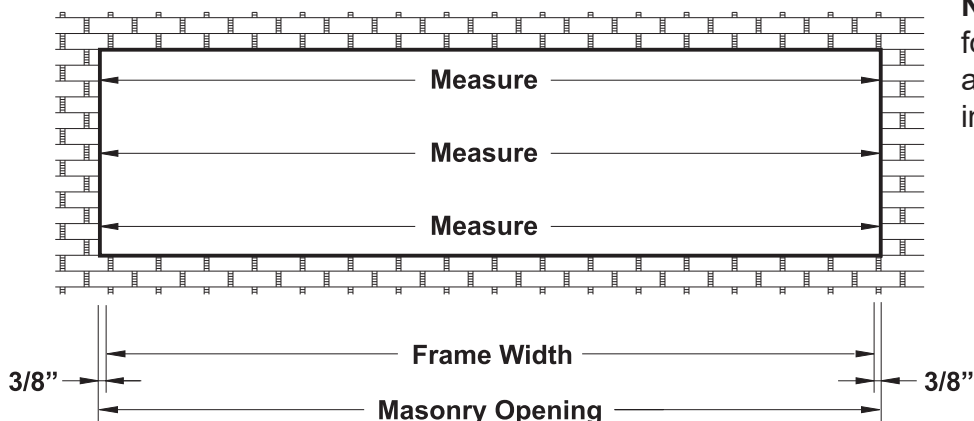

Detail 1

- Measure the width of the masonry opening at the top, middle, and bottom.
 - Select the smallest dimension measured and subtract 3/4" to determine the frame width.
- See **Detail 1**.

Determine Frame Height:

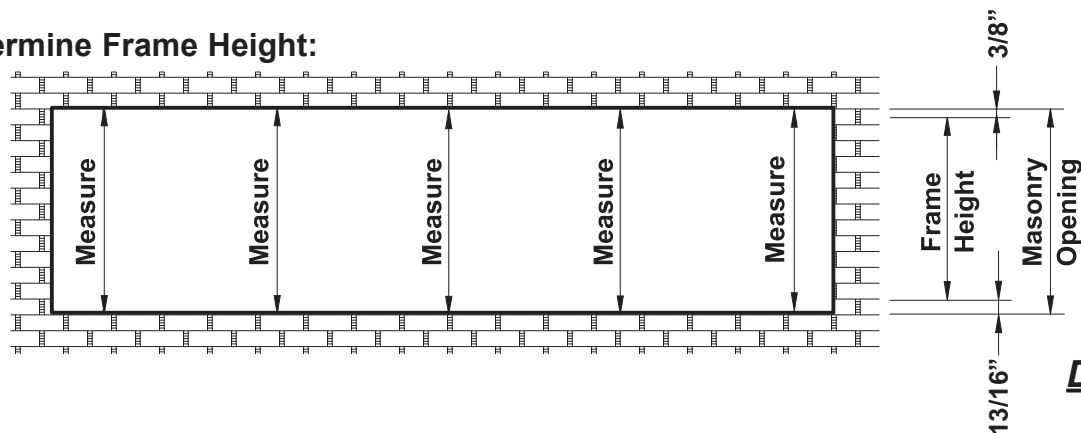

Detail 2

- Measure the height of the masonry opening in several places along the entire length of the opening.
- Select the smallest dimension measured and subtract 1-3/16" to determine the frame height to be used:
 - 3/8" for the shim/caulk joint at the head.
 - 7/16" for the sill flashing.
 - 3/8" for the shim/caulk joint below the sill flashing.

See **Detail 2**.

FRAME FABRICATION

STEP 1 (Continued)
DETERMINE FRAME SIZE

Determine Frame Height for Slab Edge Conditions:

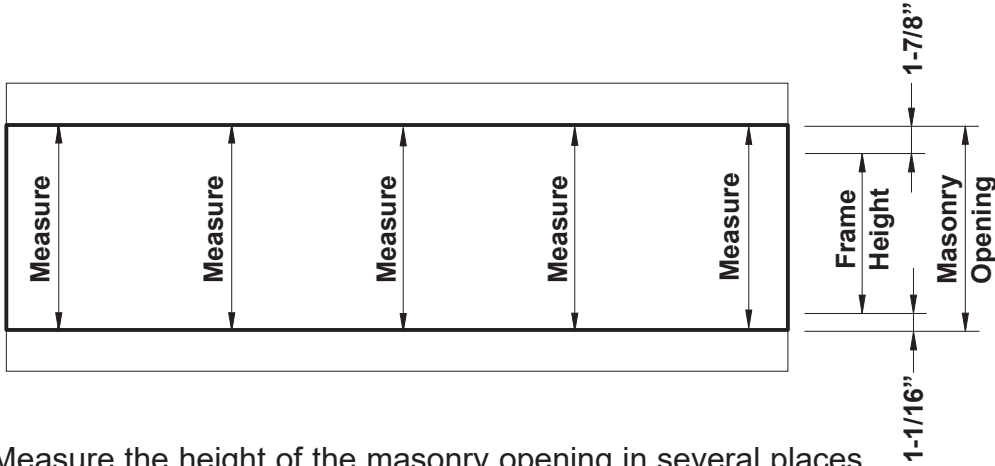

Detail 3

- Measure the height of the masonry opening in several places along the entire length of the opening.
- Select the smallest dimension measured and subtract 2-15/16" to determine the frame height to be used:
 - 5/8" for the shim/caulk joint at the head.
 - 1-1/4" for the head receptor.
 - 7/16" for the sill flashing.
 - 5/8" for the shim/caulk joint below the sill flashing.

See **Detail 3**.

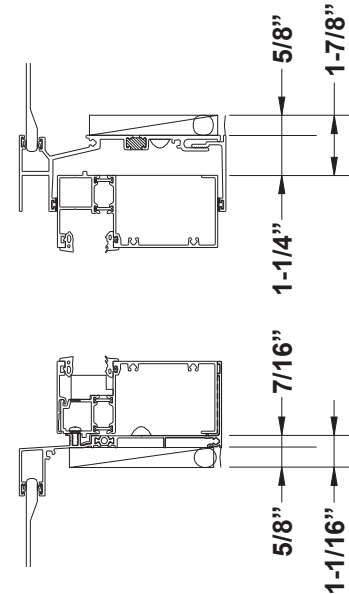

FRAME FABRICATION

STEP 2 FABRICATE SILL FLASHING

YWW 50 T requires the use of extruded sill flashing for continuous head and sill frames:

- Cut the sill flashing, BE9-2812, BE9-2818, BE9-2814 as determined in **Step 1**: Frame width plus(+) 1/4" at each jamb.
- For openings longer than 24'-0" the sill flashing needs to be spliced every twelve to fifteen feet.
- Allow for a 3/8" splice joint between sill flashing members.
- Mark the centerline of each vertical mullion on the sill flashing.

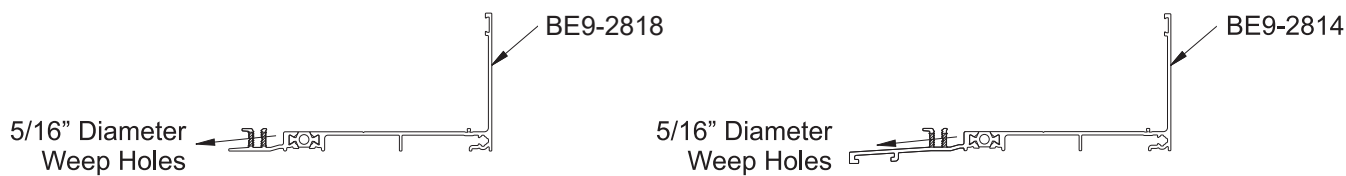
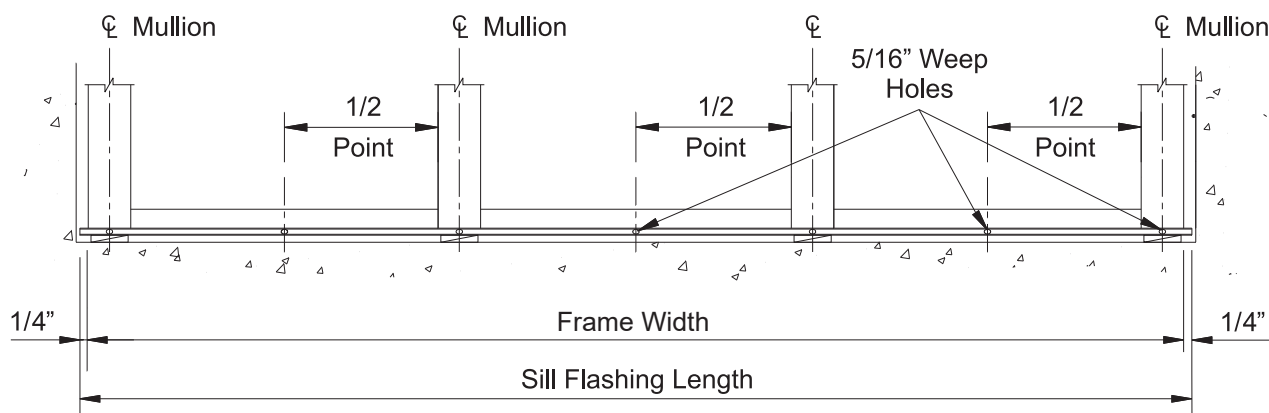

Detail 4

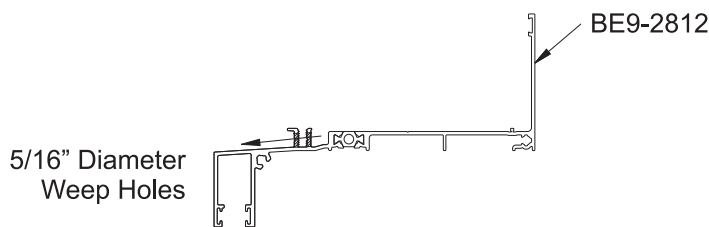

- Drill a 5/16" diameter weep hole in the face of the sill flashing at the centerline of each vertical mullion and at the midpoints between vertical mullions.

See **Detail 4**.

NOTE: Sill flashing is required for installation.

FRAME FABRICATION

STEP 3 FABRICATE HEAD & SILL MEMBERS

FOR VERTICAL THROUGH FRAMES

-Cut all head and sill members to the daylight opening between verticals.

Sill members require additional fabrication for anchoring to the sill flashing.

- Measure in 6" from each end of the sill member and mark hole locations along the glazing pocket "V"-groove.
- Mark additional hole locations a maximum of 24" on center (O.C.).
- Drill 0.213" diameter (#3 drill bit) holes at the underside of the "V" groove.
- Drill 7/16" diameter access holes at the top of the sill.

See **Detail 5**.

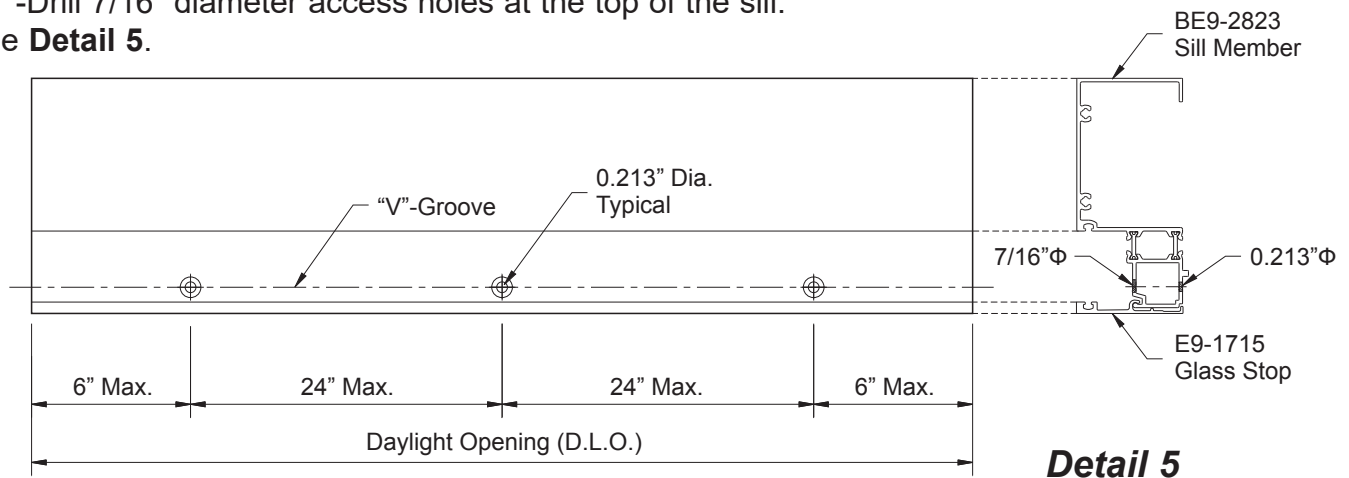

FOR CONTINUOUS HEAD & SILL FRAMES (YWW 50 T SSG Only)

With the YWW 50 T Structural Silicone Glazed (SSG) option, head and sill members may run continuously across the frame.

For Frames 24'-0" or shorter:

- Cut the head and sill members, BE9-2816, to the frame width determined in **Step 1**.

For Frames Longer Than 24'-0":

- Head member BE9-2801 and sill member BE9-2823 must be used instead of BE9-2816.
- Determine the location of the expansion mullions from the shop drawings (typically ten to fifteen feet on center).
- Cut the head and sill members to the dimension between the jamb and expansion mullions at end members and between the expansion mullions for intermediate members.

FRAME FABRICATION

STEP 3 (Continued)

FABRICATE HEAD & SILL MEMBERS

FOR CONTINUOUS HEAD & SILL FRAMES (YWW 50 T SSG Only)

-Mark the centerline of each SSG vertical member along the head and sill members.
 -Mark hole locations on the head and sill members for screw spline attachment of vertical members using one of the methods below:

-Using short pieces of vertical members as a template, align the template with the vertical centerline and the front of the head/sill and mark hole locations through the screw splines.

OR

-Layout hole locations on head and sill members as shown in **Detail 6**.

-Drill 0.236" diameter (#B drill bit) clearance holes at each location marked.

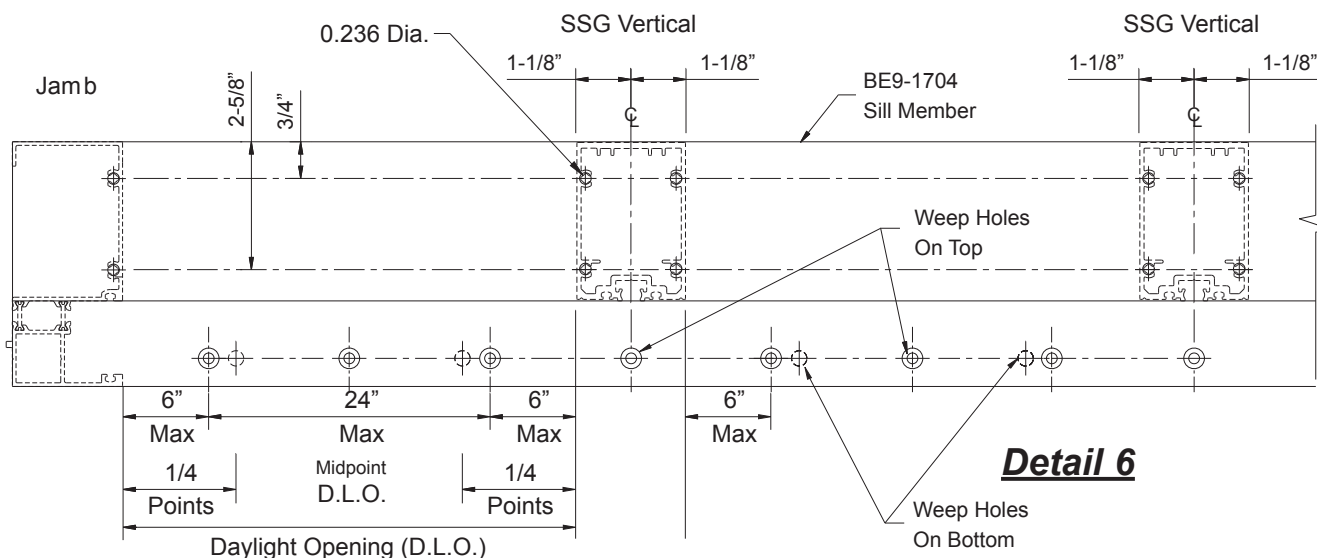

Detail 6

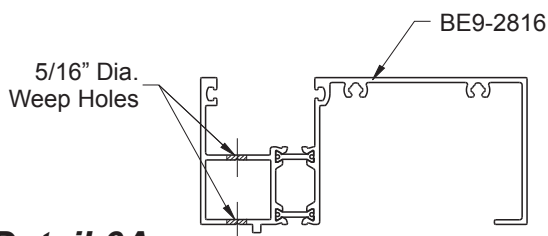

Detail 6A

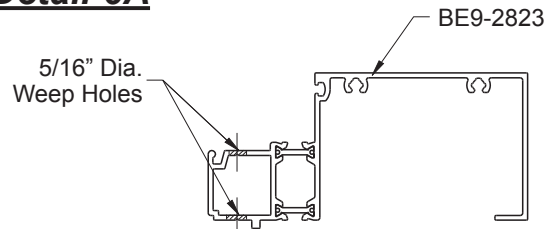

Continuous sill members must have weep holes drilled for each lite of glass.

-Mark the centerline of each intermediate vertical and the midpoint of D.L.O. between verticals in the glazing pocket of the sill.

-Turn the sill member over and mark the quarter points of D.L.O. between verticals on the bottom.

-Drill a 5/16" dia. hole at each hole location marked just in front of the thermal break.

See **Detail 6A**.

FRAME FABRICATION

STEP 4

FABRICATE SSG MULLIONS & JAMB MEMBERS

-Cut two piece verticals, fillers, and jamb members to the frame height minus (-) 4-1/2” as determined in **Step 1** on **Page 11** or as shown on approved shop drawings.

Fabrication of Verticals for Inside Glazed Frames:

- Use a short piece of each horizontal member as a template.
- Center the template on the face of the vertical member.
- Line up the glazing pockets and mark the location of each screw spline.

-OR-

- Layout the hole locations along the “V”-grooves of each member as shown in **Detail 7**.
- Drill a 0.189” diameter hole at each location marked.

Note: Drill fixture can be used.

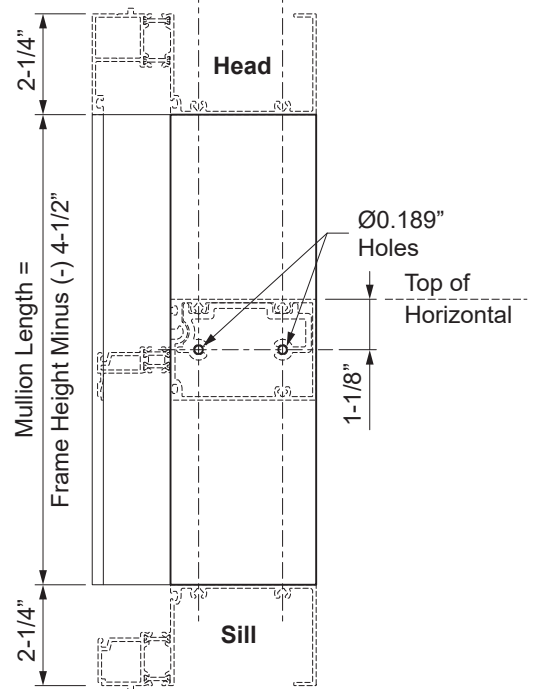
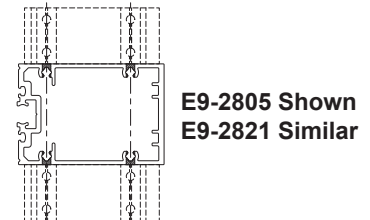
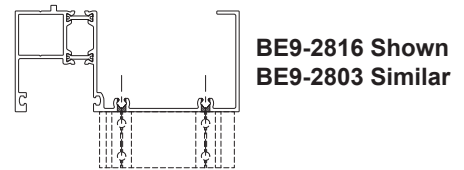

Detail 7

FRAME FABRICATION

STEP 4 (Continued)

FABRICATE TWO PIECE VERTICALS & JAMB MEMBERS

-Cut two piece verticals, fillers, and jamb members to the frame height determined in **Step 1** on **Page 11** or as shown on approved shop drawings.

Fabrication of Verticals for Outside Glazed Frames:

- Use a short piece of each horizontal member as a template.
- Center the template on the face of the vertical member.
- Line up the glazing pockets and mark the location of each screw spline.

-OR-

- Layout the hole locations along the “V”-grooves of each member as shown in **Detail 8**.
- Drill a 0.234” diameter hole at each location marked.

Note: Drill fixture can be used.

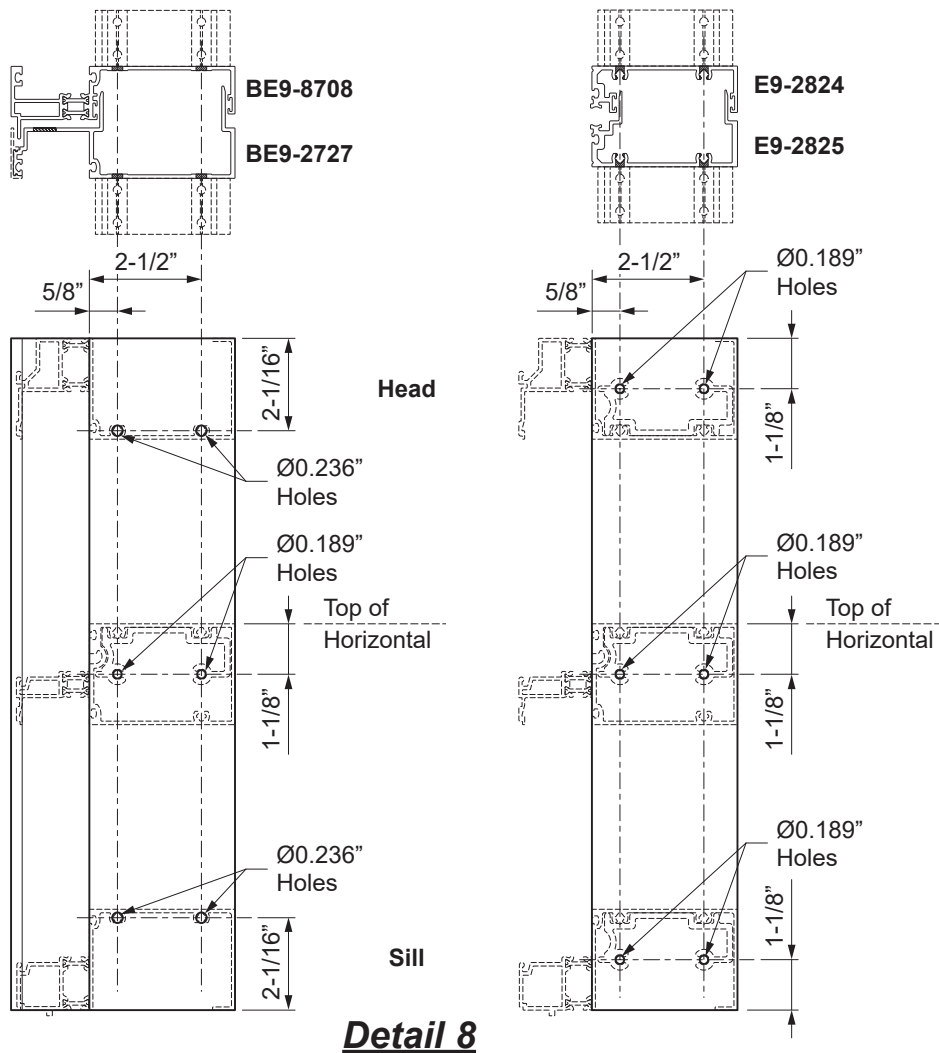

FRAME FABRICATION

STEP 6

FABRICATE EXTERIOR GLASS STOP FOR OUTSIDE GLAZED HORIZONTALS

- Exterior glazed horizontals require exterior glass stops:
 - BE9-8706 and BE9-8728 requires interior glass stop E9-1715.
- Cut the glass stop to the same dimension as the horizontals (D.L.O.) minus (-) 1/32". See **Detail 9**.

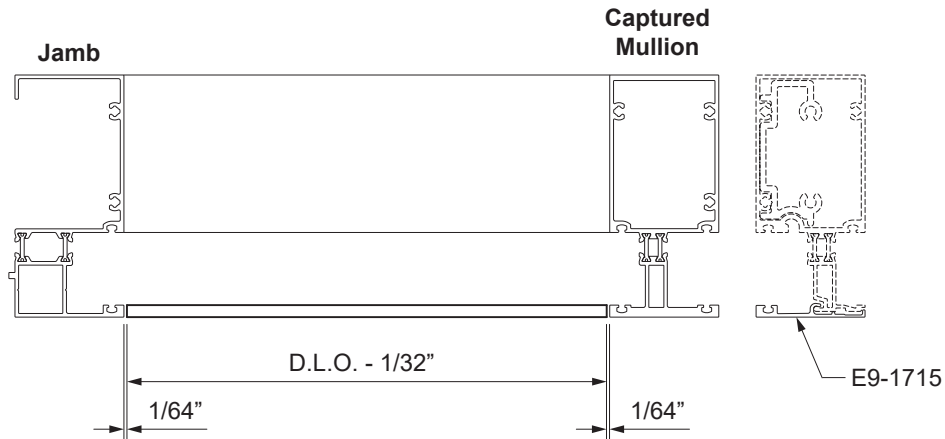

Detail 9

FRAME FABRICATION

STEP 6 (continued)

FABRICATE EXTERIOR GLASS STOP FOR OUTSIDE GLAZED HORIZONTALS

Structural Silicone Glazing (SSG):

- For frame widths 24'-0" or less cut the face covers to the frame width minus 4-9/16".
- For frame widths greater than 24'-0" face members are spliced every ten to fifteen feet at the center of an intermediate vertical.
- Allow for a 1/32" joint at each jamb and a 3/8" joint between face cover splices.

Caution: DO NOT splice the face cover at an expansion mullion!

See Detail 10A.

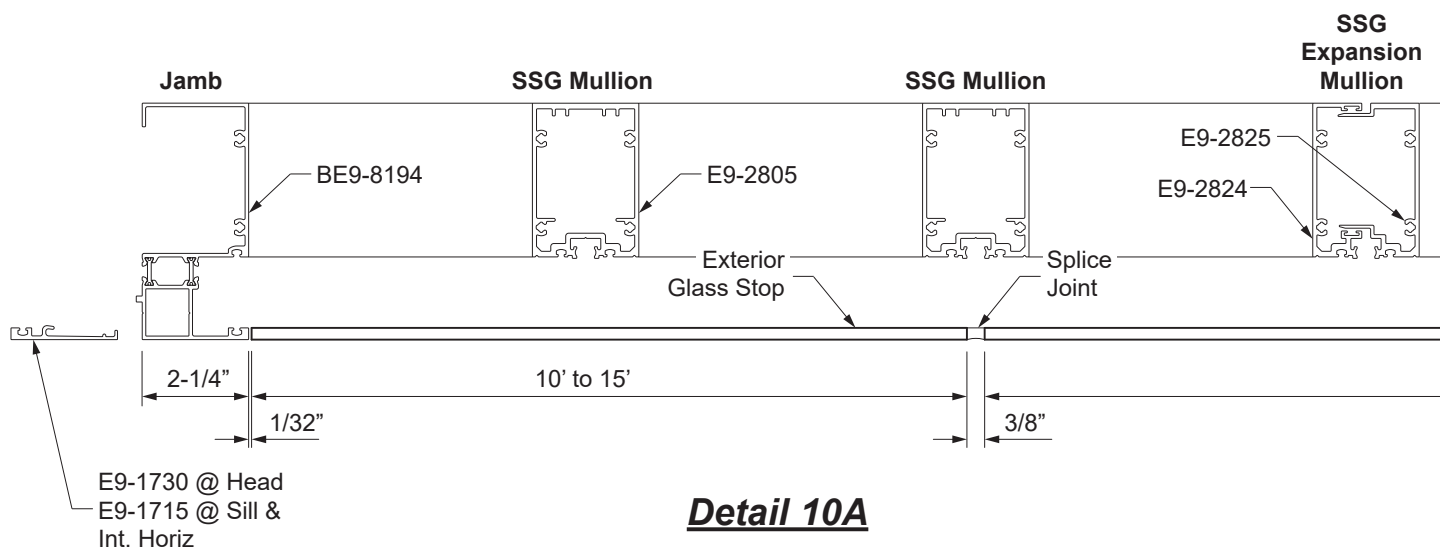

FRAME FABRICATION

STEP 6 (continued)

FABRICATE EXTERIOR GLASS STOP FOR OUTSIDE GLAZED HORIZONTALS

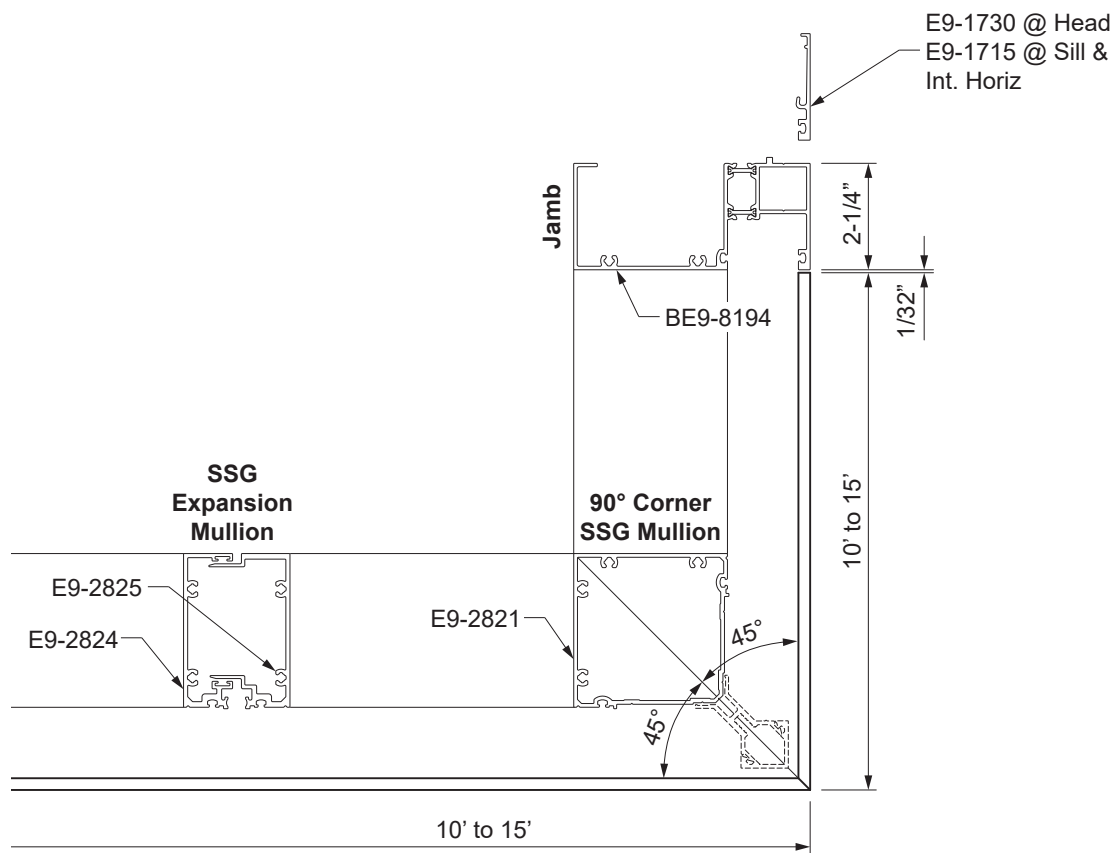

Detail 10B

FRAME FABRICATION

**STEP 6
FABRICATE GLAZING ADAPTORS**

YWW 50 T offers glazing adaptors for 1/4" glazing:

- E9-1707 for captured mullion deep pockets.
- E9-1708 for captured mullion shallow pockets.
- E9-2716 for structural silicone glazed (SSG) vertical mullions.
- E9-1725 for BE9-8734 pocket fillers for 90° corner posts and door jambs.

- Cut vertical glazing adaptors to the daylight opening dimension between horizontals plus(+) 7/8".
- Cut horizontal glazing adaptors to the daylight opening dimension between verticals minus(-) 1/32".

Glazing adaptor, E9-2716, requires additional fabrication:

- Mark hole locations along the recessed area in the middle of the adaptor 2" from each end and 12" on center.
- Drill 0.213" (#3 bit) dia. holes at each location marked.

See **Detail 11**.

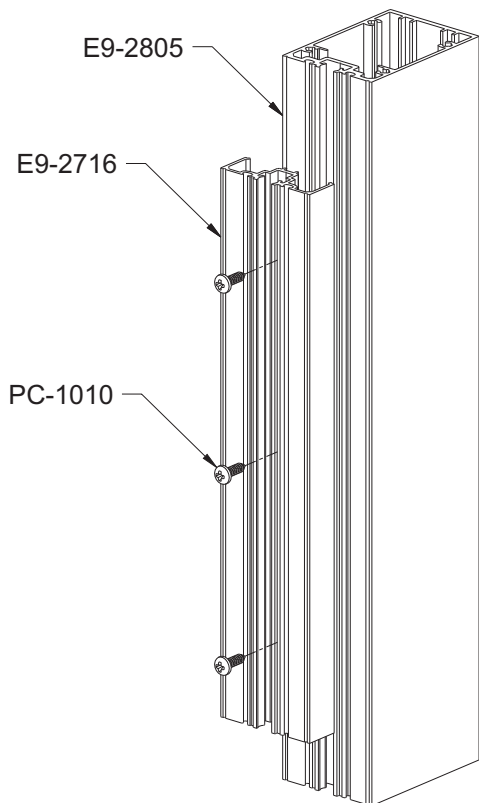

Detail 11

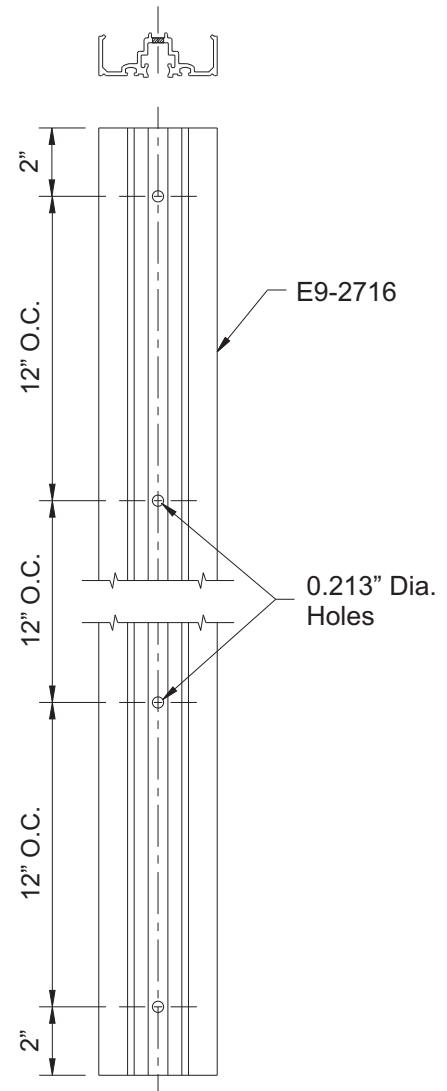

FRAME FABRICATION

STEP 7
FABRICATE PLATE ADAPTOR

- Cut the aluminum plate adaptor, E9-8222, to the same length as the sill flashing.
- Notch the aluminum plate adaptor 2-1/2" from each end where adjacent to a splice location as shown in **Detail 12**.

Detail 12

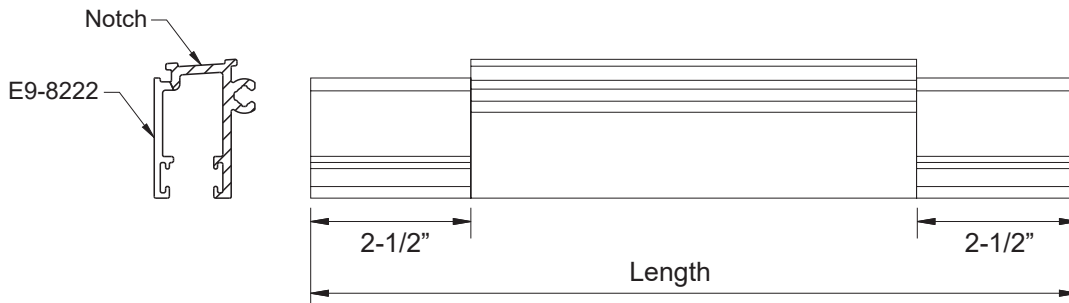

- Drill a hole at each location marked for anchoring to the sill flashing. Anchor size and location as determined by structural calculations.
- Alternate perimeter fasteners as shown with dimensions a and b.

Note: It is necessary to also notch the sill flashing 2-1/2" from each end where adjacent to a splice location as shown in **Detail 13**.

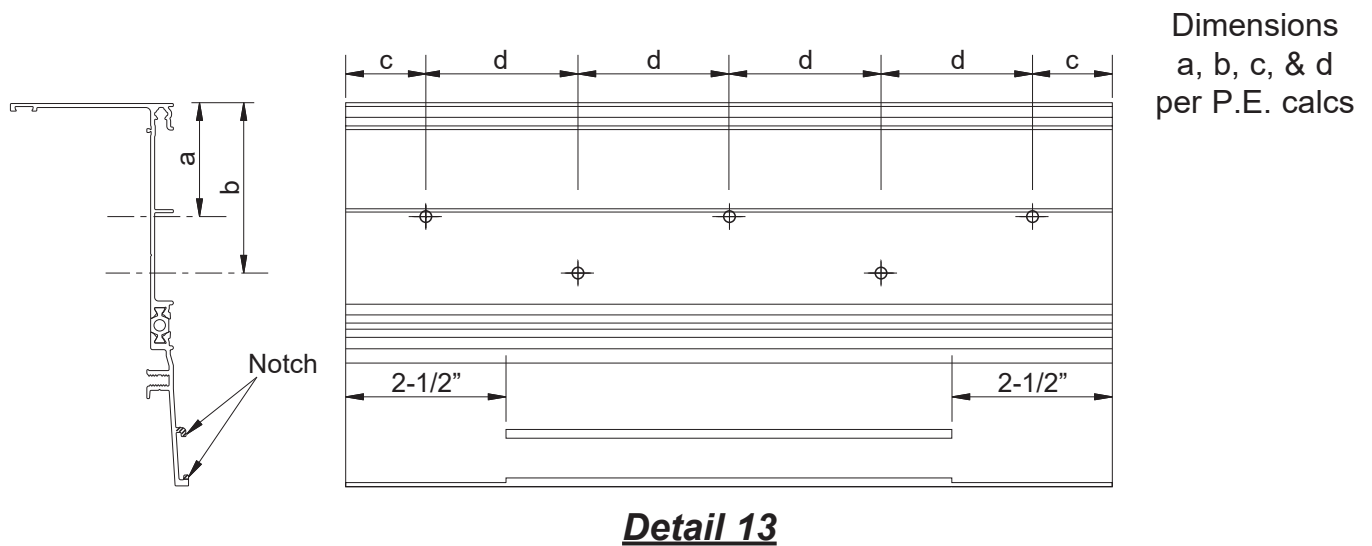

Detail 13

FRAME FABRICATION

STEP 8

FABRICATE HEAD RECEPTOR AND SLAB EDGE COVER

- Cut the head receptor and snap cover to the same dimension of the sill flashing as determined in **Step 2**.
- Alternate perimeter fasteners and drill weep holes as shown in **Detail 14**.

Dimensions
c, d, e, & f
per P.E. calcs

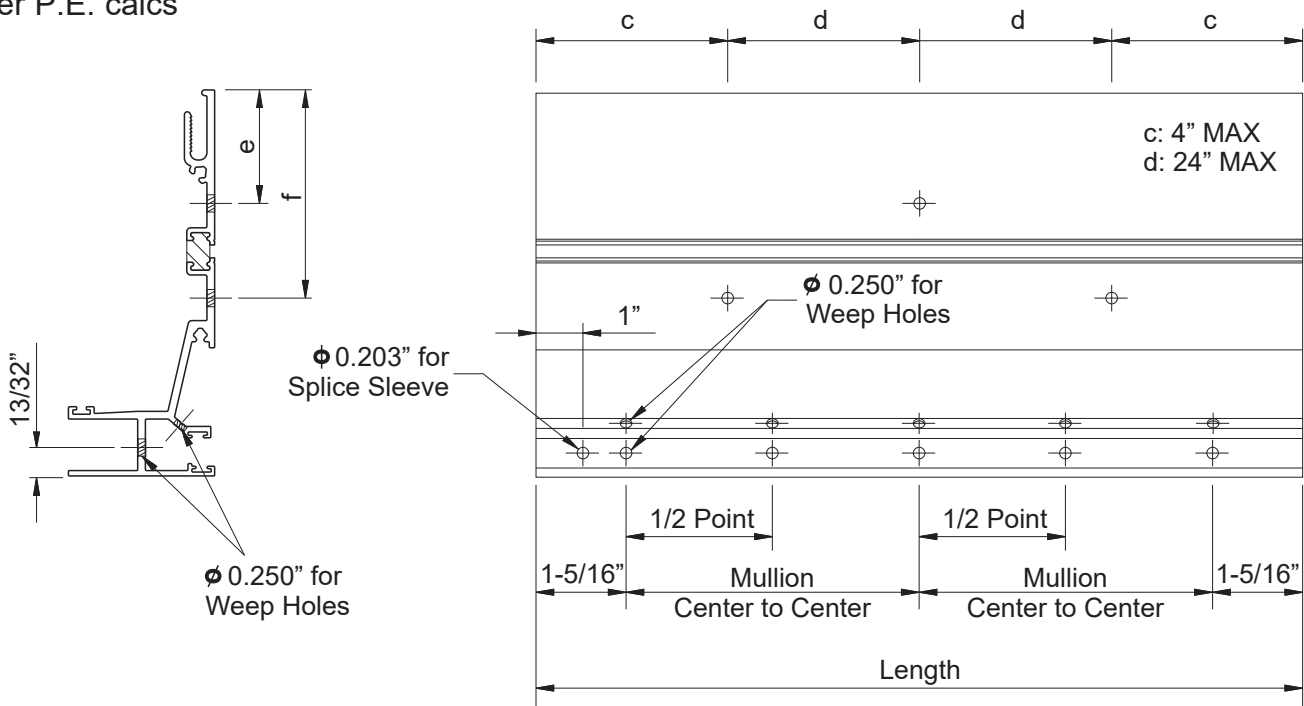

Detail 14

FRAME FABRICATION

STEP 9

FABRICATE HEAD NEAR EXPANSION JOINT (Captured Verticals Only)

The square nubs at the head will need to be notched at the expansion mullions to clear the end caps.

-Cut the nub 1/2" at the expansion mullion half of which the end cap is not attached to.

See **Detail 15**.

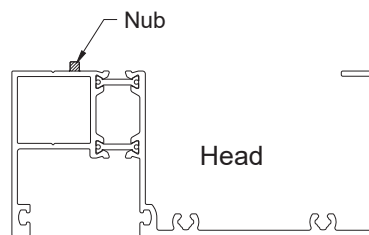

Detail 15

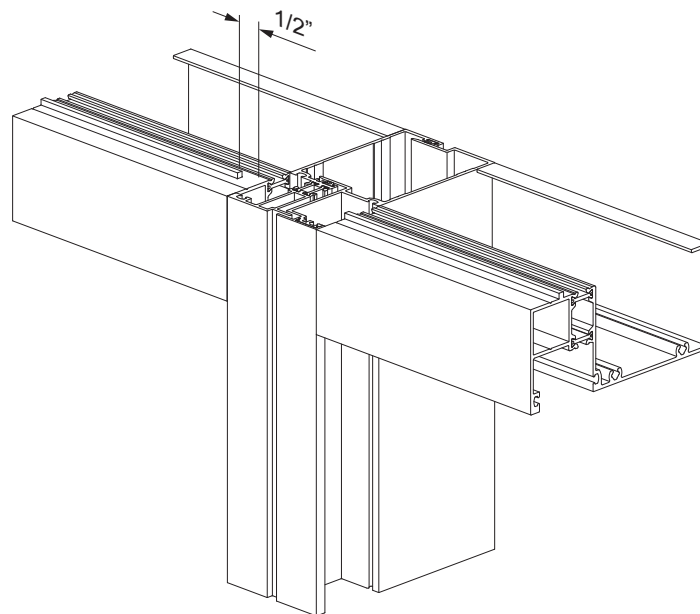

FRAME ASSEMBLY

STEP 10 ATTACH MULLION END CAPS

Mullion end caps are required at the top of the expansion mullion of continuous head and sill frames.

- Clean the vertical mullion ends and mullion end caps with a cleaner and method approved by the sealant manufacturer.
- Apply sealant to the gasket reglet and along the front of the vertical members on both ends prior to installing mullion end caps . For expansion mullions, apply sealant to the fastener side mullion only.
- Attach the mullion end caps to each end of the mullion with fasteners as shown **Detail 16**.
- Install E1-2806 mullion cap as shown on expansion mullion half. On the SSG expansion mullion, use the E1-2805 mullion cap.
- Tool the excess sealant along the inside of the glazing pocket between the mullion end cap and the mullion.

Field note: At the top of each mullion, the perimeter sealant must cover the extrusions entire front edge, thus completely covering the mullion cap.

- Seal all screw heads.
- See **Detail 15**.

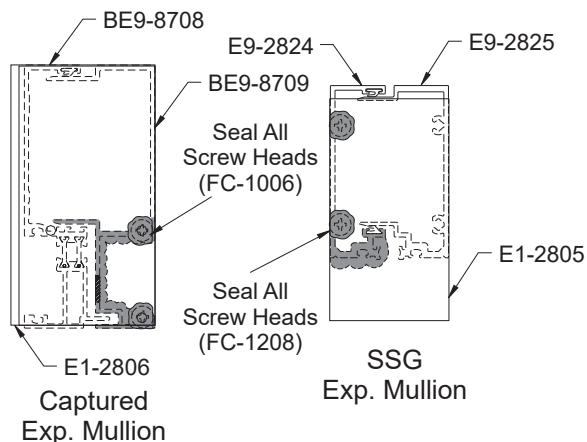

Detail 16

STEP 11 INSTALL END DAMS (For Continuous Head & Sill Frames Only)

The ends of head and sill members of continuous head & sill frames must be plugged using end dams, E2-0193 and E2-0194.

Use the following technique to install end dams at the head and sill:

- Clean the ends of the head and sill members with a cleaner and method approved by sealant manufacturer.
- Apply sealant to all contact sides of the end dam.
- Insert the end dam into each end, leaving it 1/8" recessed from the edge of the mullion.
- Apply sealant to the end dams and tool the sealant flush with the ends of the mullion.

See **Detail 17** (sill shown, head similar).

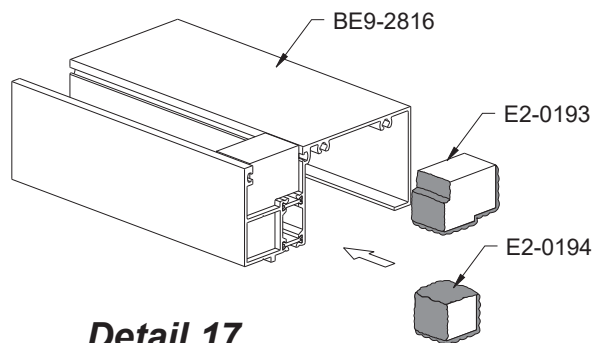

Detail 17

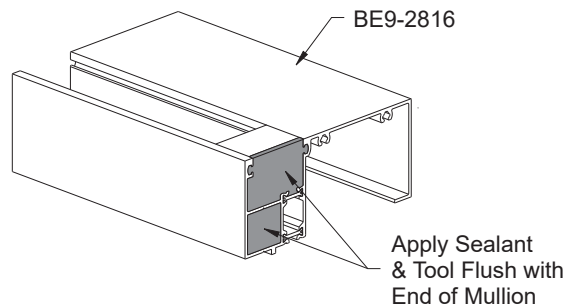

FRAME ASSEMBLY

**STEP 12
PREPARE FRAMES FOR ASSEMBLY**

Continuous Head & Sill Frames:

-Preparation is similar to Vertical Through Frames. Apply sealant to the ends of the Continuous Head and Sill members as shown in **Detail 18**.

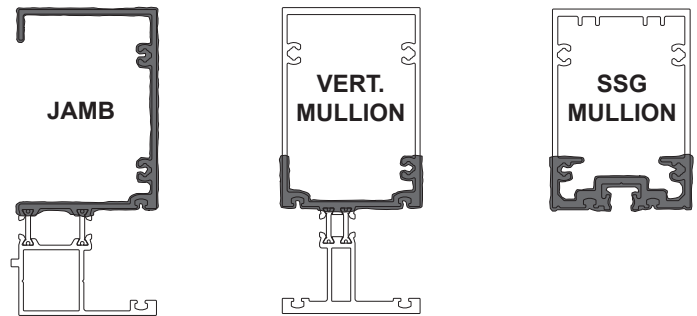

**STEP 12A
ASSEMBLE FRAMES**

**Continuous Head & Sill Frames
With One Piece SSG Verticals:**

- Attach jamb members to continuous head and sill members using (2) PC-1220 fasteners at each end.
- Attach one piece verticals to continuous head and sill members using (4) PC-1220 fasteners at each end.
- Attach intermediate horizontals to shear block, E1-2802, using (2) FC-1212 fasteners at each end.

See **Detail 19**.

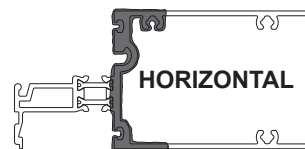

Detail 18

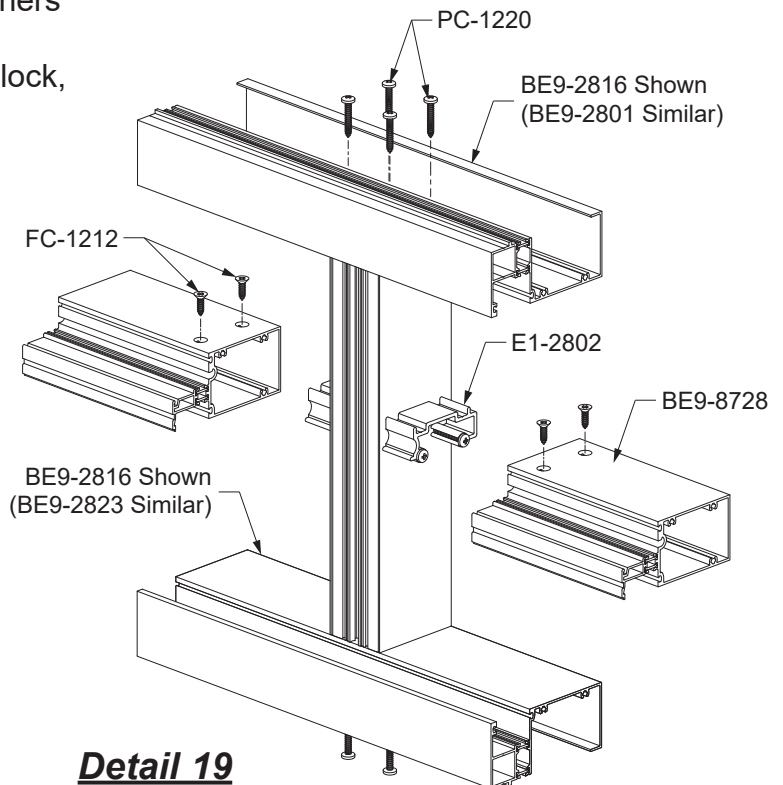

Detail 19

FRAME ASSEMBLY

**STEP 14
ASSEMBLE SILL FLASHING FOR SLAB EDGE COVER**

- Install 2 rows of gasket, E2-0065 at the slab edge cover pocket side of the plate adaptor, E9-8222, or into the integrated adaptor of the BE9-2812 sill flashing.
- Install the aluminum plate adaptor into the BE9-2814 sill flashing, by sliding into place.

See **Detail 20**.

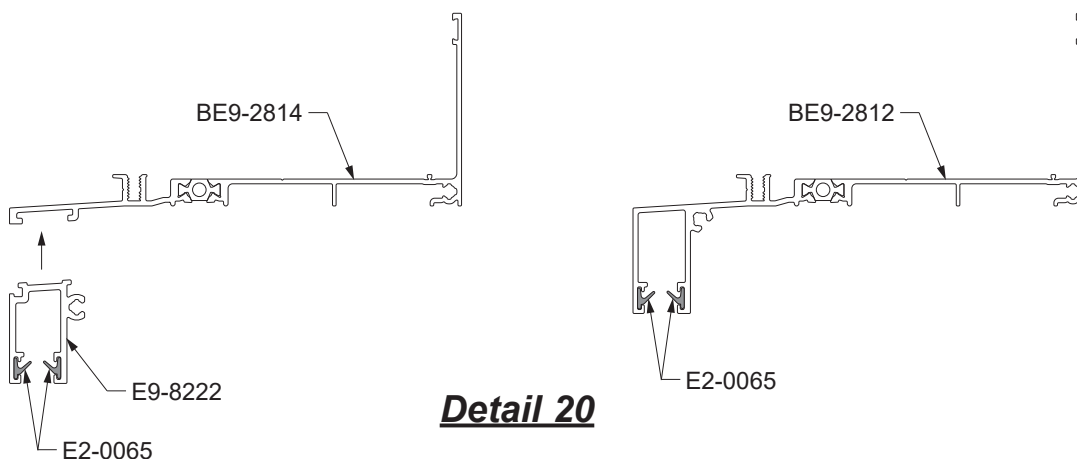

- At the jamb, clean all joint surfaces using cleaner approved by sealant manufacturer.
- Apply silicone sealant to the end of the plate adaptor region as shown in **Detail 21**.
- Fasten the appropriate end dam into the plate adaptor using one UA-1212 fastener.

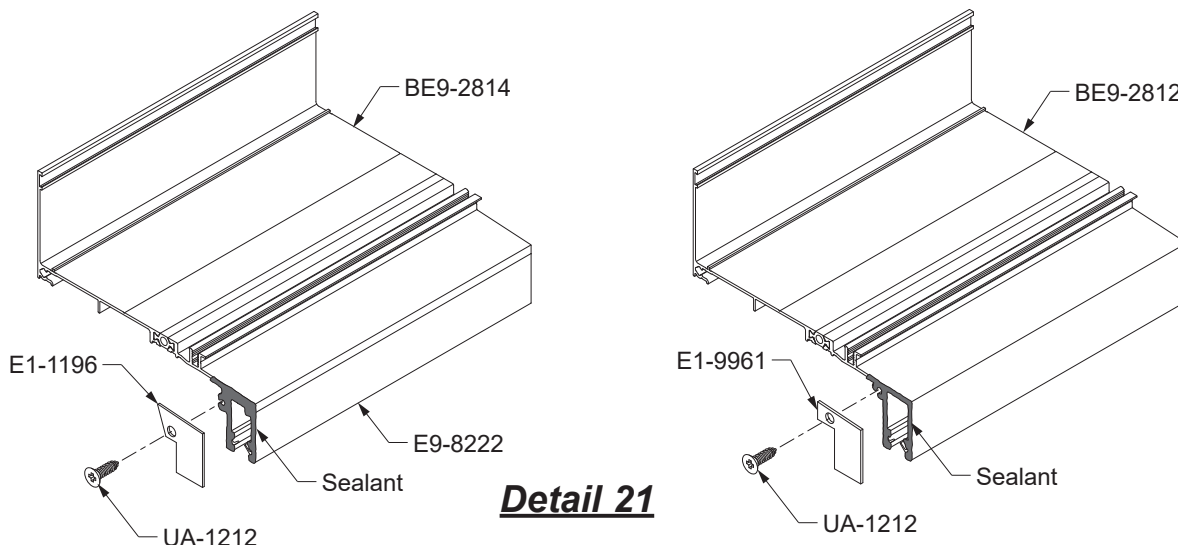

FRAME ASSEMBLY

STEP 15

ASSEMBLE HEAD RECEPTOR FOR SLAB EDGE COVER

- Install weep baffle, E2-0099, over every weep hole location.
- Install gasket, E2-0051, (cut to receptor length plus 3/8") on YWW 50 T frame side of receptor.
- Install gasket, E2-0051, (cut to receptor snap cover length) onto the E9-8720 snap cover.
- Install two rows of gasket, E2-0065, on the slab edge cover pocket side of head receptor.

See **Detail 22**.

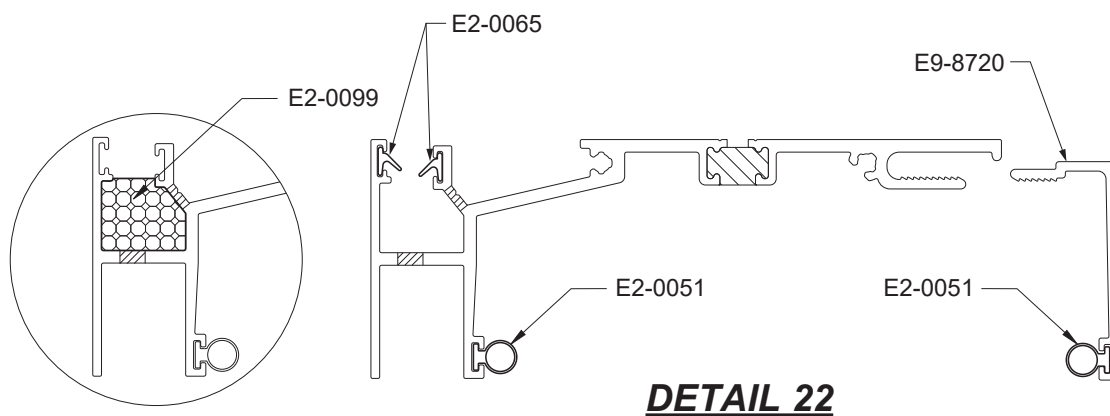

- Clean the ends of the receptor using cleaner approved by sealant manufacturer.
- Where the receptor is used at the jamb, apply sealant to the end as shown in **Detail 23A**.
- Attach the E1-9952 end dam to the head receptor using two UA-1212 fasteners.
- On the inside of the end dam, tool sealant as shown in Detail 35B.
- At splice joints, the E1-9957 end dam is used. Apply sealant as shown in **Detail 23B**.
- Attach the E1-9957 end dam with one UA-1212 fastener.

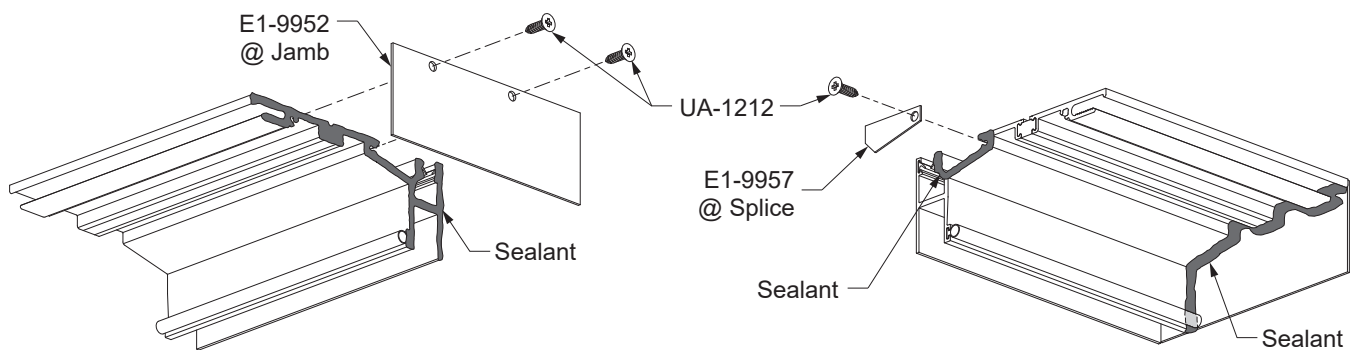

DETAIL 23A

DETAIL 23B

FRAME ASSEMBLY

STEP 15 (Continued)

ASSEMBLE HEAD RECEPTOR FOR SLAB EDGE COVER

-On the inside of the E1-9957 end cap, tool sealant as shown in **Detail 23C**.

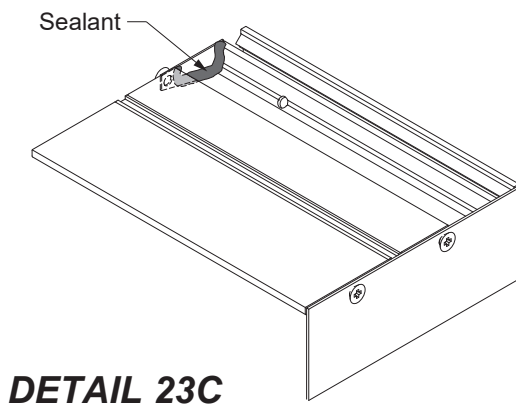

DETAIL 23C

STEP 16

ASSEMBLE SLAB EDGE COVER PLATES

- Clean the ends of the slab edge cover and attachment areas of end caps using a cleaner approved by sealant manufacturer.
- Apply and tool sealant to each end of the slab edge cover prior to attaching the end caps.
- Attach end caps to each end of the slab edge cover using (2) UA-1212 fasteners.
- Tool and wipe away any excess sealant at the joints.

See **Detail 24**.

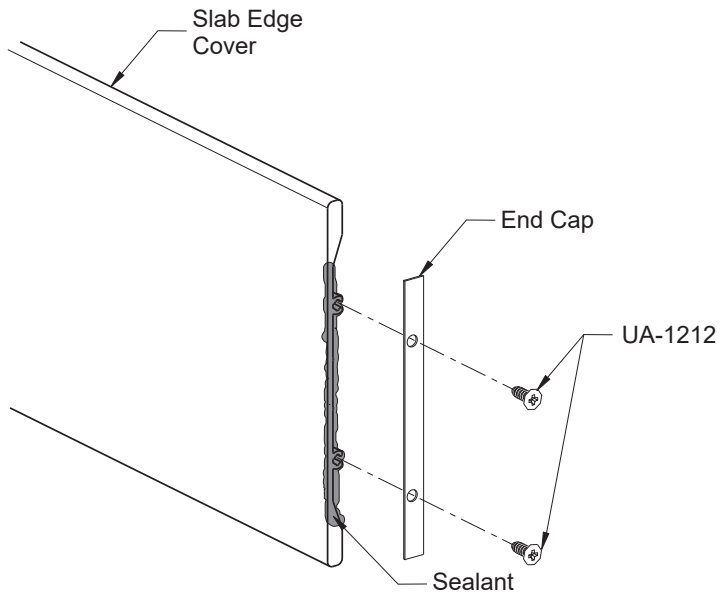

DETAIL 24

FRAME INSTALLATION

STEP 17 INSTALL SILL FLASHING

Note: For slab edge cover applications, see **Step 21** on **Page 34**.

- Starting at the smallest opening height, install the sill flashing with a minimum of 3/8" shim underneath. Sill flashing must be installed level.
- Anchor the sill flashing to the structure a maximum of 4" from each end and then 18" to 24" on center.
- Apply and tool sealant to cover the heads of all fasteners.

STEP 18 INSTALL SILL FLASHING SPLICE SLEEVE

- Remove the nub with a chisel or needle nose pliers a minimum length of 1-1/2" as shown in **Detail 25**.
- After the sill flashing has been shimmed and installed to the building structure, apply a small backer rod under the sill flashing as shown in **Detail 27**.
- Position the Silicone Splice Sleeve against the back wall below the groove.
- Bend the Silicone Splice Sleeve into the front on the channel as shown. Mark, and cut the sleeve at this position.
- Clean Sill Flashing and Silicone Splice Sleeve with isopropyl alcohol at the splice location
- Seal the flashing at the splice location as shown in **Detail 26**, before positioning the flashing. Set the Silicone Splice Sleeve into the sealant and flashing.
- Tool sealant tight as shown in **Detail 28**, squeezing the sheet flat.
- Thoroughly seal the small joint directly in front of the Silicone Splice Sleeve as shown in **Detail 28**.

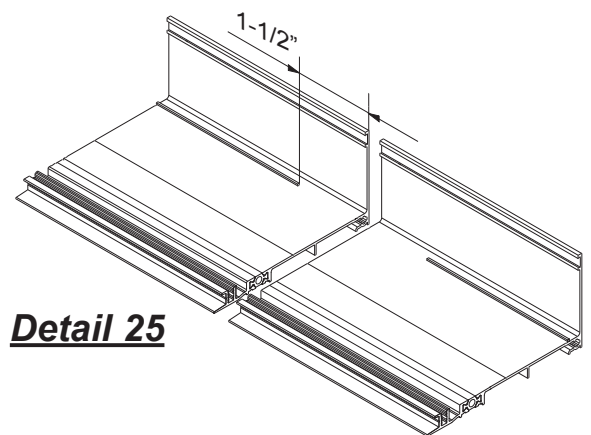

Detail 25

When using E2-0070, a compatible Silicone Sealant must be used at the splice. Compatible Silicone Sealants include Tremco Spectrum 2 and Dow Corning 795.

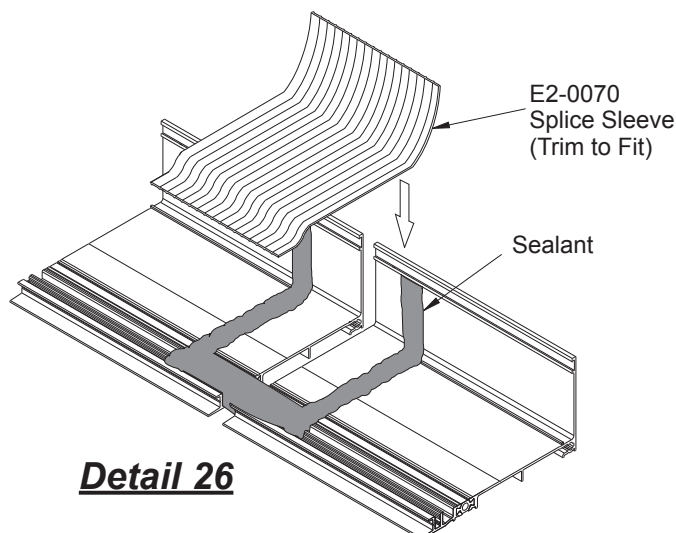

Detail 26

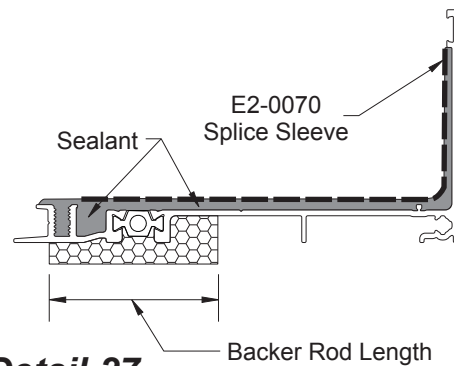

Detail 27

FRAME INSTALLATION

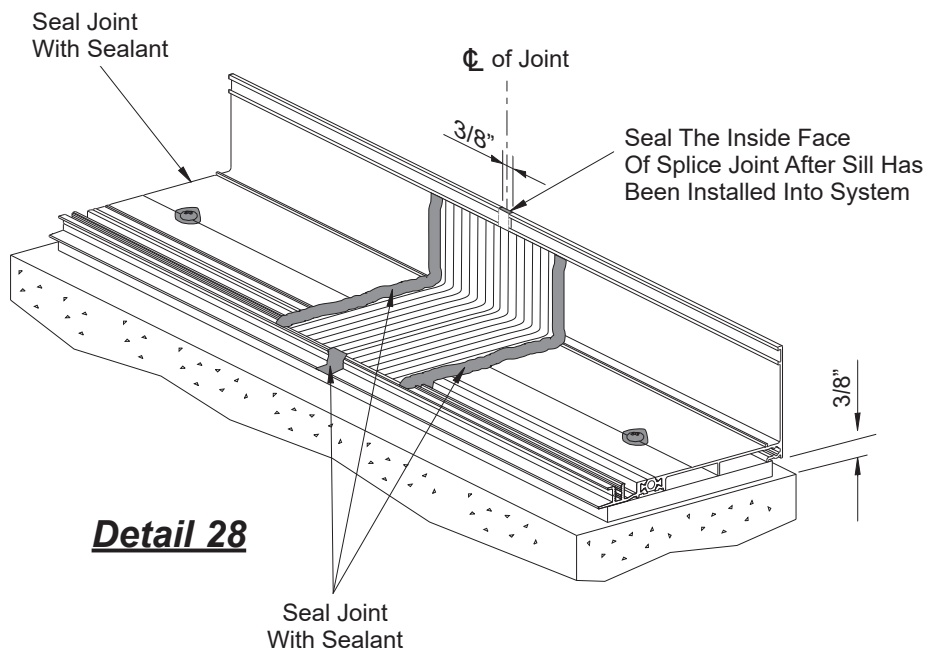

**STEP 19
SILL PREPARATION**

At every sill flashing splice condition, apply bond breaker tape to the back of the sill member before it is placed into the sill flashing. See **Detail 29**.

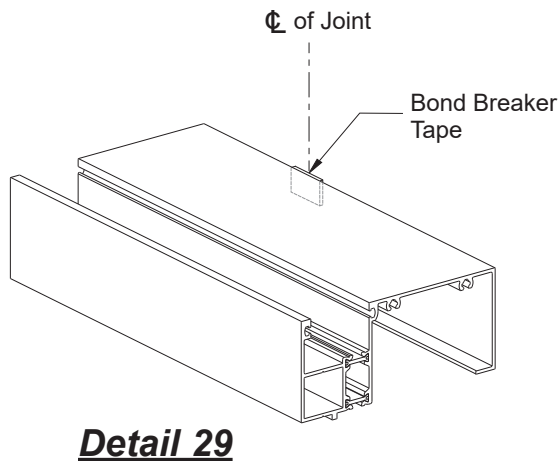

FRAME INSTALLATION

STEP 20 INSTALL SILL FLASHING AT CORNERS

- Cut two 12" long pieces of sill flashing and miter (45° for 90° corners and 67.5° for 135° corners).
 - Align the two pieces at the corner condition with the mitered ends pushed together tight and anchor the sill flashing as called out on shop drawings.
 - Apply and tool sealant to the mitered joint and anchor heads.
- See **Detail 30**.
- Continue installing the rest of the sill flashing providing a 3/8" expansion joint at splices as shown in **Step 18** on **Page 27 & 28**.

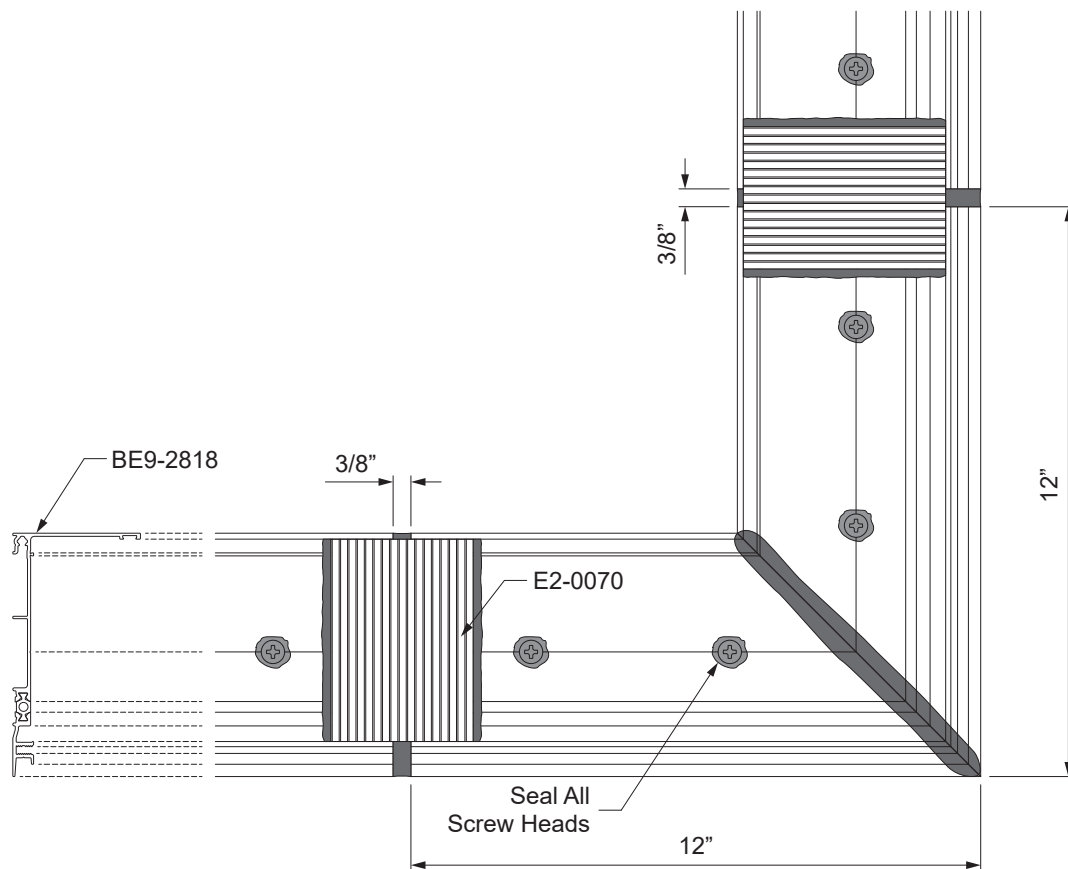

Detail 30
90° Outside Corner Shown
Others Similar

FRAME INSTALLATION

STEP 20A

INSTALL BE9-2814 / BE9-2812 SILL FLASHING AT CORNERS *

- Cut two 13-3/16" long pieces of sill flashing and E9-8222 slab edge cover adaptor, and miter (45° for 90° corners). The head receptor that is to be installed below will also receive the same miter cut fabrication.
- Install the head receptor using similar procedure as previously described for the sill flashing.
- Miter cut the slab edge cover plates 45° for 90° corners, such that upon installation, they leave a 1/2" gap at the corner.
- Fasten end caps onto the edge of the slab edge cover plates.
- Install the slab edge plates onto the setting blocks of the head receptor below.
- Align the two pieces of the sill flashing at the corner condition with the mitered ends pushed together tight and anchor the sill flashing as indicated on the approved shop drawings and or P.E. calculations.
- Apply and tool sealant to the mitered joint and anchor heads.

See **Detail 31**.

- Continue installing the rest of the sill flashing providing a 3/8" expansion joint at splices as shown in **Step 18 Pages 27 & 28**.

* **Note:** Similar technique required for head receptor.

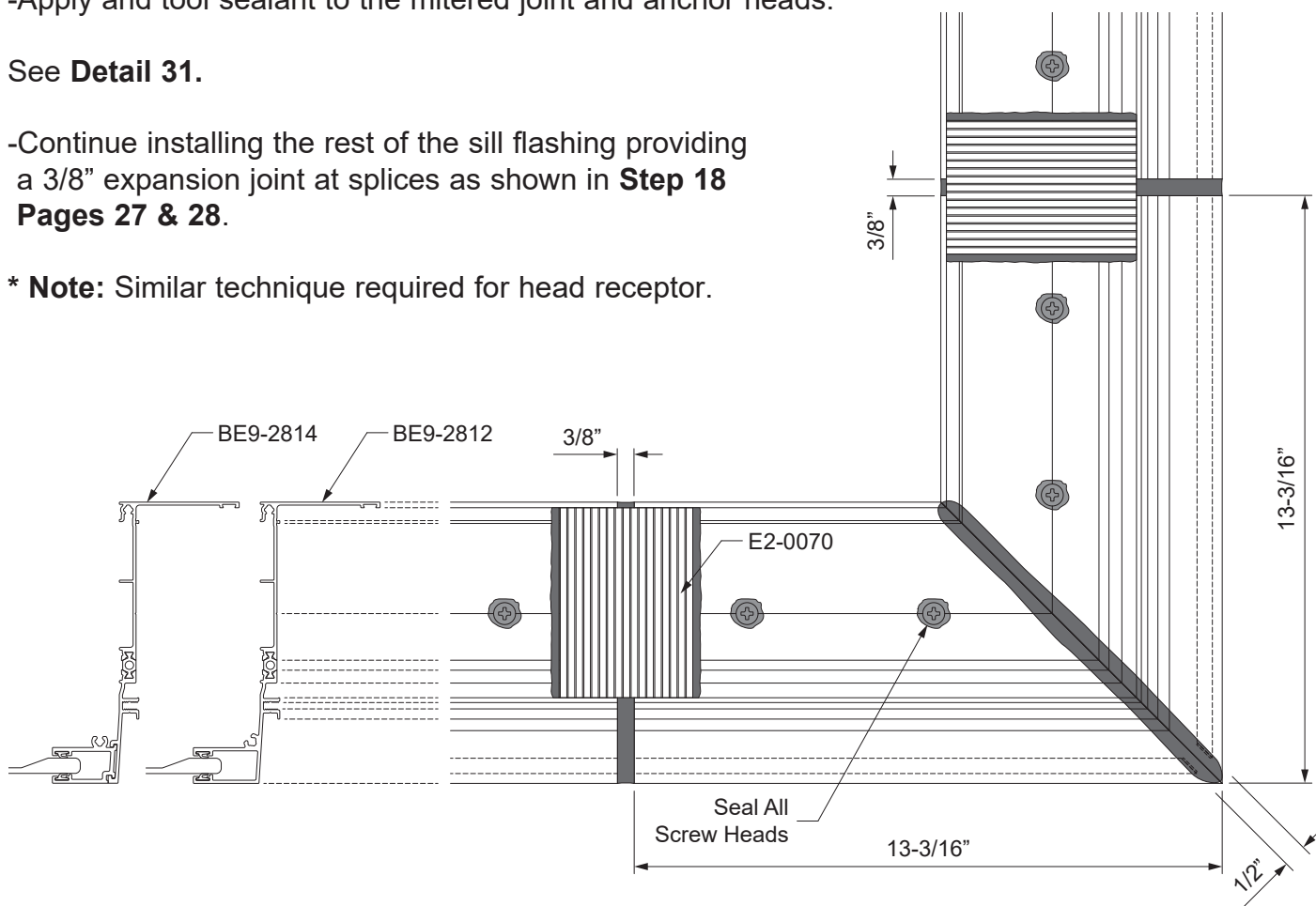

Detail 31

90° Outside Corner Shown
Others Similar

FRAME INSTALLATION

STEP 21 INSTALL HEAD RECEPTORS

With slab edge cover applications, the head receptor of the system below is installed first, then the slab edge cover, and then the sill flashing with slab edge adaptor for the system above.

- Starting at the smallest opening height, install the head receptor with a minimum of 1/2" shim space underneath. Head receptor must be installed level. Allow for a 3/8" splice joint between spans.
- Anchor the head receptor to the structure a maximum of 4" from each end and then 18" to 24" on center.
- Apply and tool sealant to the heads of all fasteners.

See **Detail 32**.

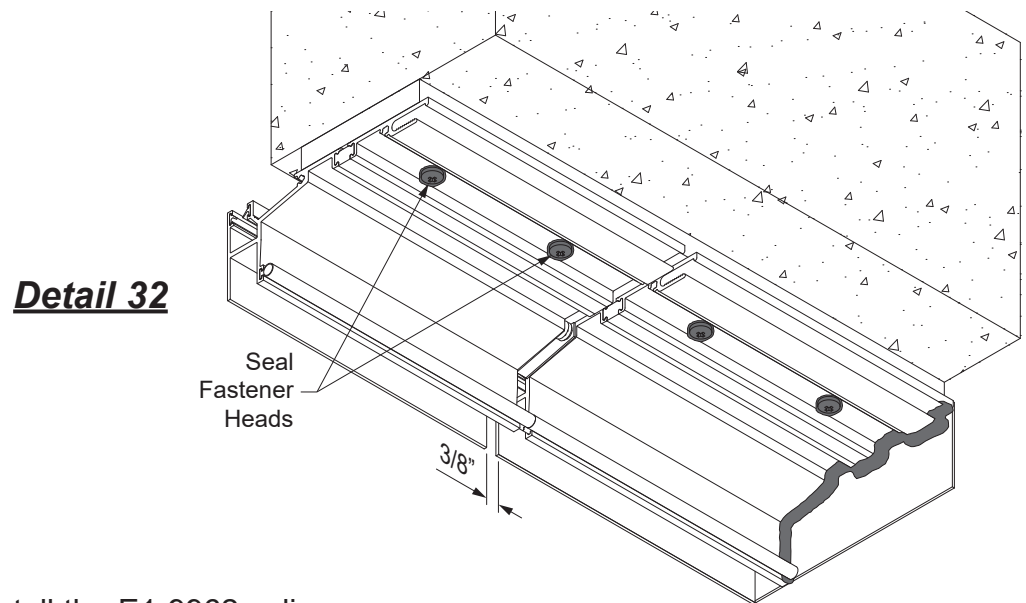

-At each splice location, install the E1-9962 splice sleeve, centered at the splice joint, using one PC-1006-SS fastener as shown in **Detail 33A**.

-In the slab edge receptacle above, adhere an E2-0070 silicone sheet to the receptor with sealant, also centered at the splice joint. Note that there will be a bulge where the fastener below penetrates the receptacle.

See **Detail 33B**.

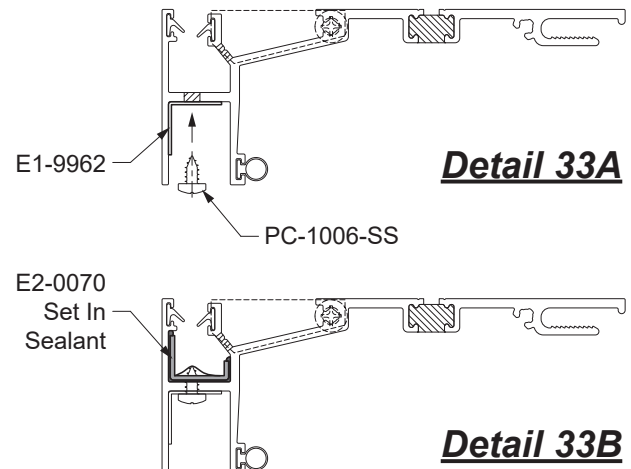

FRAME INSTALLATION

**STEP 21 (Continued)
INSTALL HEAD RECEPTORS**

-Prior to installing the E1-2813 splice sleeve, clean head receptor and splice sleeve with isopropyl alcohol at the splice location.

-Apply bond breaker tape to the top side of the splice sleeve at the center.

-Position the splice sleeve inside the front wall inside the head receptor, set in sealant centered on the splice joint as shown in **Detail 34**. Press the sleeve tight against the receptor.

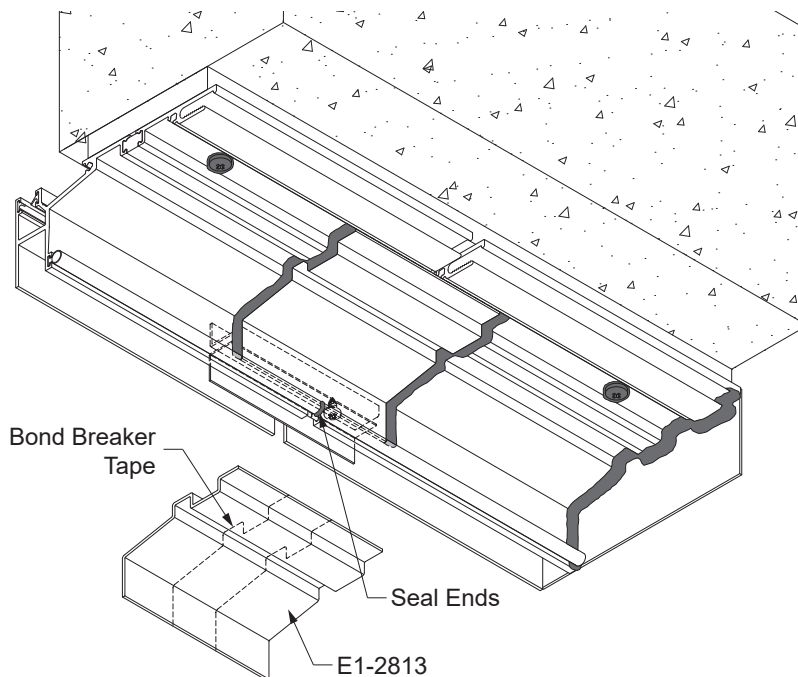

Detail 34

-Install E2-0054 setting blocks at 1/4 points of the head receptor.

See **Detail 35**.

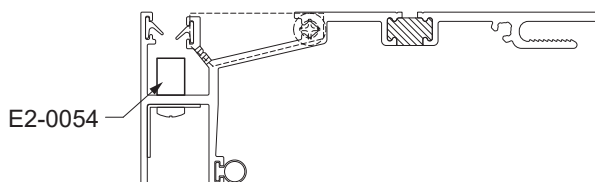

Detail 35

FRAME INSTALLATION

STEP 22 INSTALL SLAB EDGE COVER FASCIA

- Push slab edge cover into the head receptor to make contact with setting blocks, E2-0054.
- Be sure to leave a 3/8" joint between the plates for runs longer than 24'-0".

See **Detail 36**.

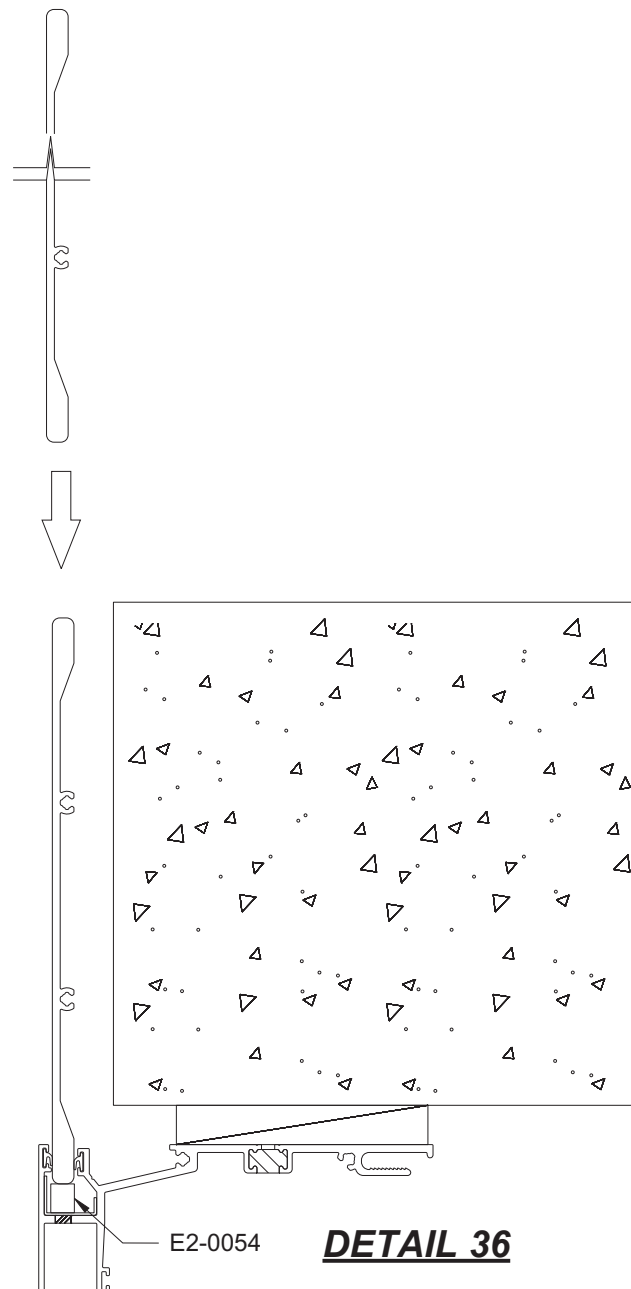

FRAME INSTALLATION

**STEP 23
INSTALL SILL FLASHING FOR SLAB EDGE COVER**

Before installing the sill flashing, install an E1-9959 splice sleeve at the underside of the sill flashing and slab edge adaptor.

- Apply bond breaker tape down the middle of the splice sleeve and sealant to one side of the splice sleeve as shown in **Detail 37**.
- Adhere the sealed half of the splice sleeve to the underside of the sill flashing.

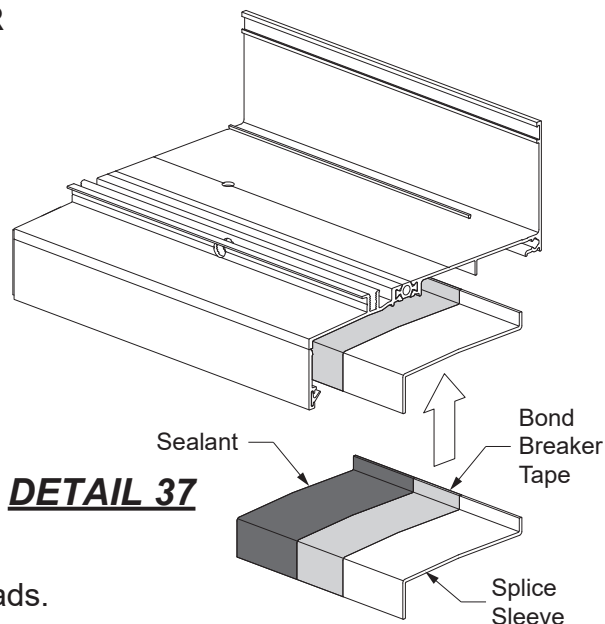

- Install the sill flashing assembly onto the substrate (1/2" minimum shim space), engaging the slab edge cover plates below and sealing all anchor fastener heads.
- Install the next slab edge sill flashing assembly onto the splice sleeve as shown in **Detail 38**. Be sure to leave a 3/8" splice joint between the sill flashing assemblies.

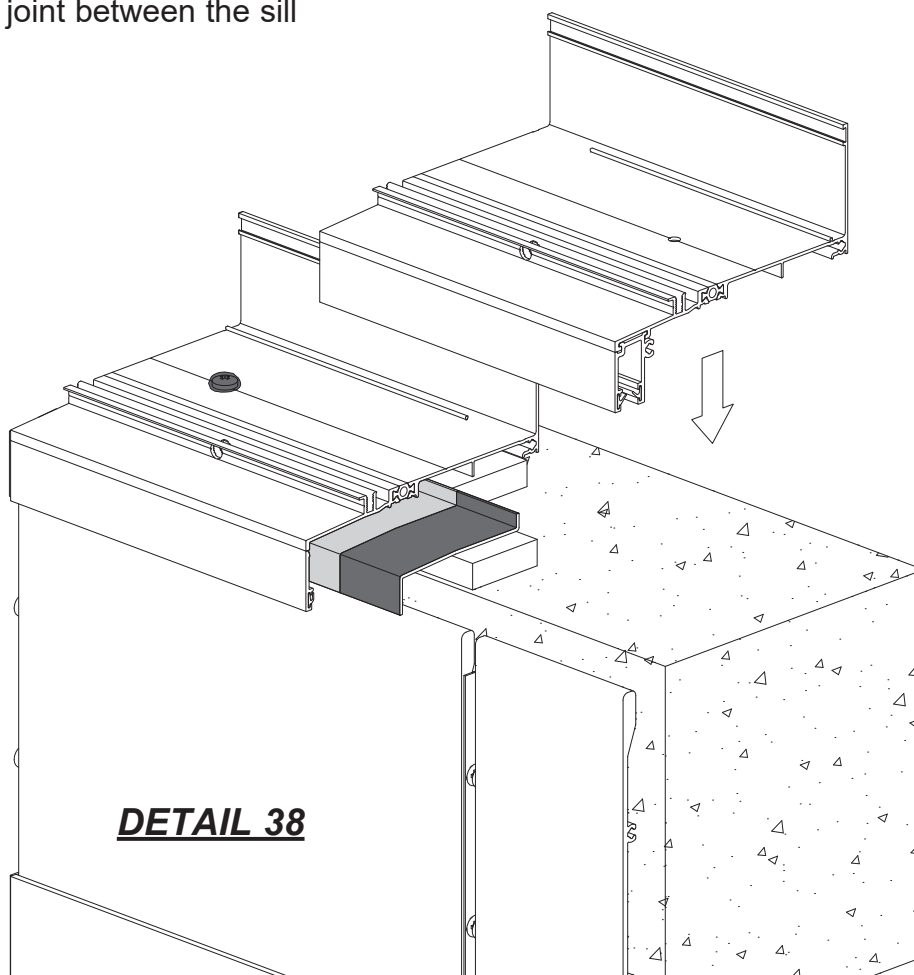

FRAME INSTALLATION

STEP 23 (Continued)

INSTALL SILL FLASHING FOR SLAB EDGE COVER

-Installation of the E2-0070 splice sleeve is the same as previously outlined in **Step 18**, except to apply sealant to the joint at the slab edge cover plate, adaptor, and head receptor as shown in **Detail 39**.

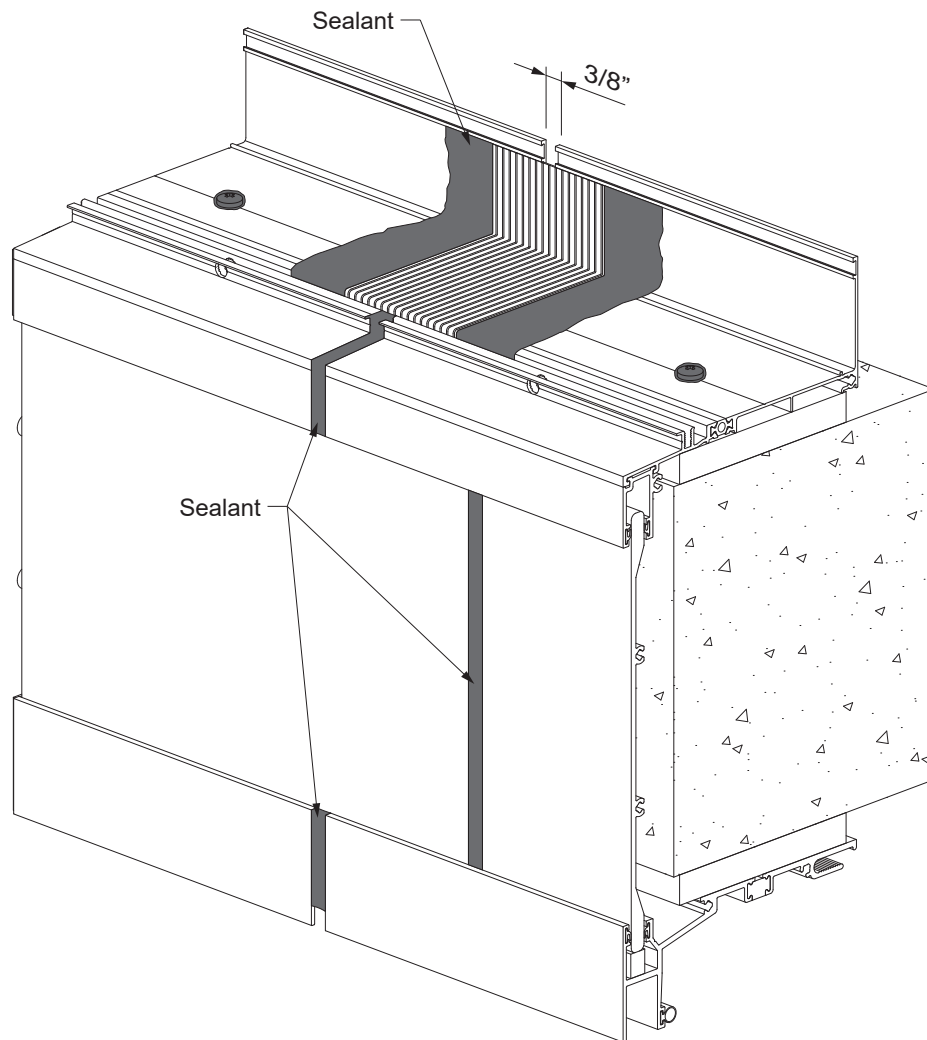

DETAIL 39

FRAME INSTALLATION

STEP 24 INSTALL ASSEMBLED FRAMES

- Immediately before installing the frames, apply a continuous bead of sealant to the top of the upturned leg of the sill flashing, and a generous amount of sealant to the pilot holes in the sill flashing. Be sure not to obstruct weep holes on exterior of sill. Make sure all surfaces are clean before applying sealant.
- Snap frame assemblies together and set onto the sill flashing.
- Shim the head and jamb members to ensure that the frame is installed plumb, square, and true.
- Anchor the head members at 6" on each side of every vertical centerline and then no more than 24" on center.
- Anchor jamb members 6" from each end and then no more than 24" on center.
- Follow by inserting and tightening fasteners into flashing through sealant.
- Seal all anchor heads.

Note: Shims must be installed at all anchor locations.

See **Detail 40**.
(Inside glazed shown, outside glazed similar)

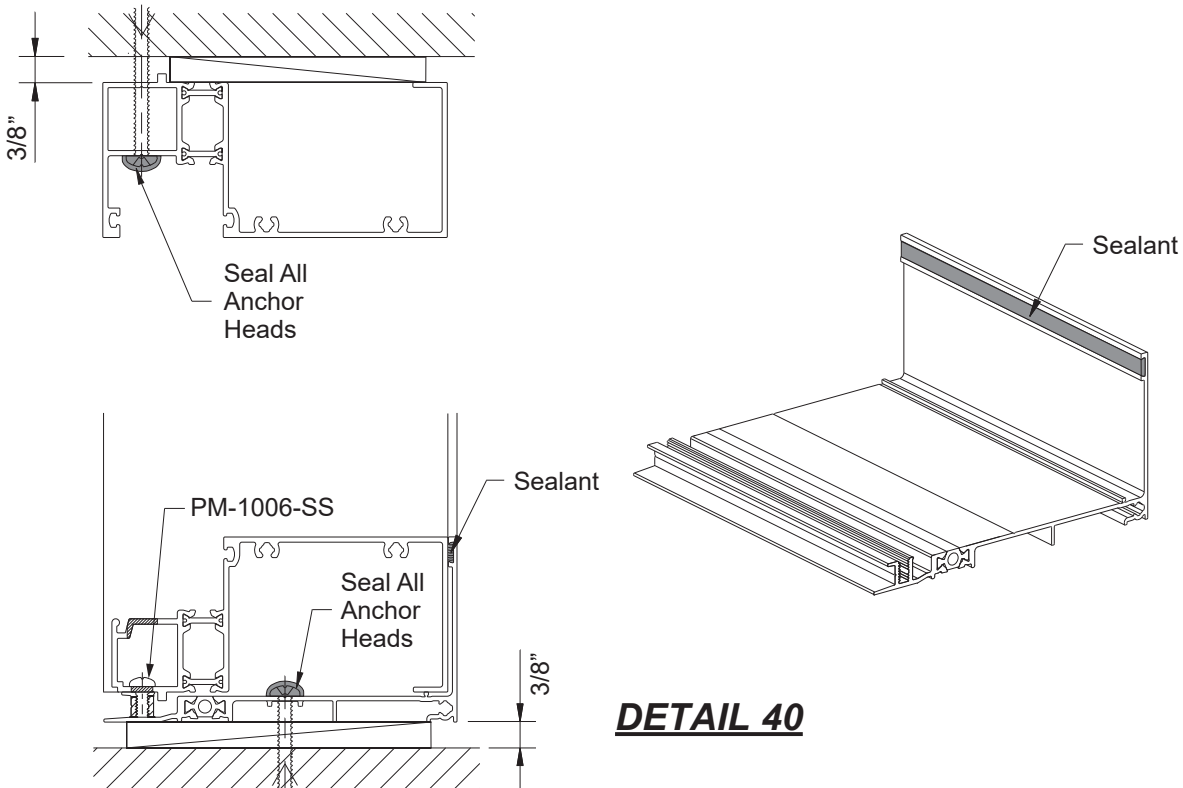

DETAIL 40

FRAME INSTALLATION

STEP 25 APPLY INTERNAL & PERIMETER SEALANT

- Apply sealant to all vertical/horizontal joints at the glazing pockets.
- Tool the sealant to ensure a watertight joint.
- See **Detail 42**.

- Install backer rod around the perimeter of the frame between the frame and the structure.
- Apply and tool sealant to ensure a watertight joint.
- See **Detail 43**.

Note: Interior and exterior seals are required.

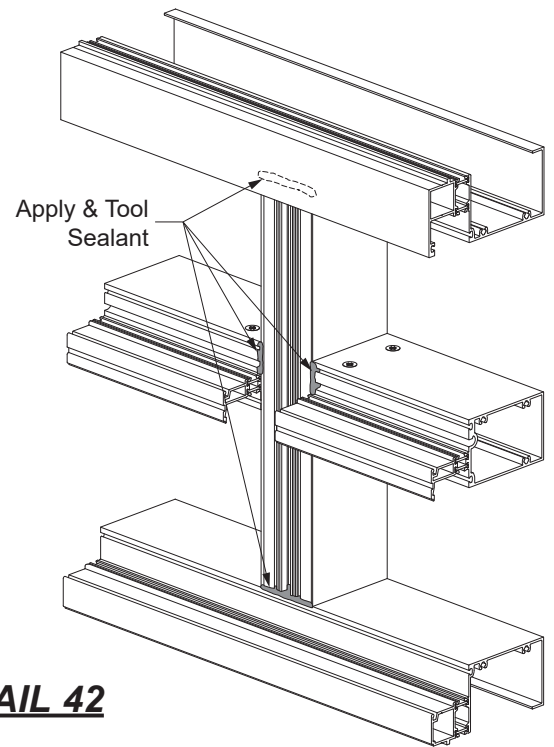

DETAIL 42

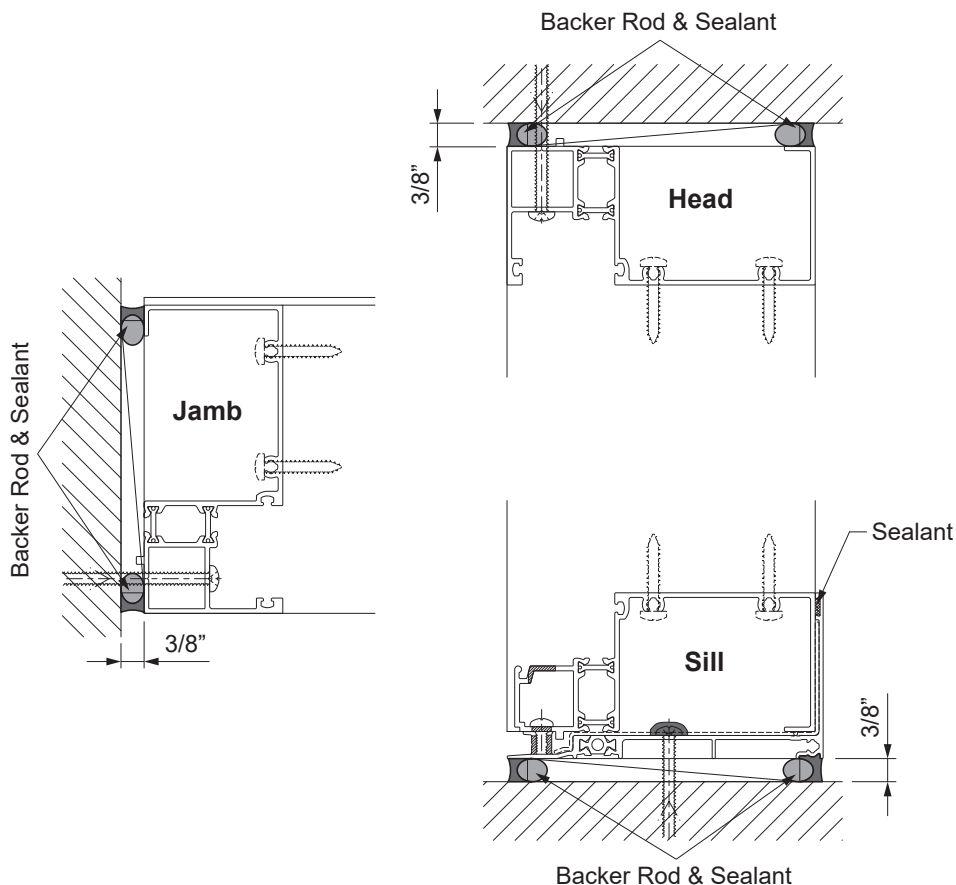

DETAIL 43

FRAME INSTALLATION**STEP 26****INSTALL ASSEMBLED FRAMES WITH SLAB EDGE COVER**

- Install E2-0098 sill weep baffle at each weep hole location.
- Clean the surfaces using cleaner approved by sealant manufacturer.

See **Detail 44**.

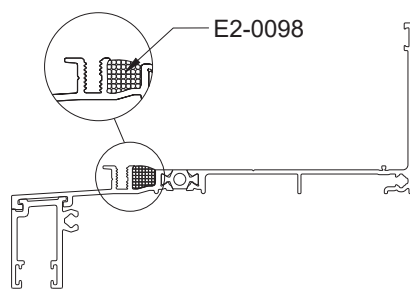

DETAIL 44

- Apply and tool sealant between wall and end dam.
- Apply and tool sealant to the sealant track on the back of the sill flashing.

See **Detail 45**.

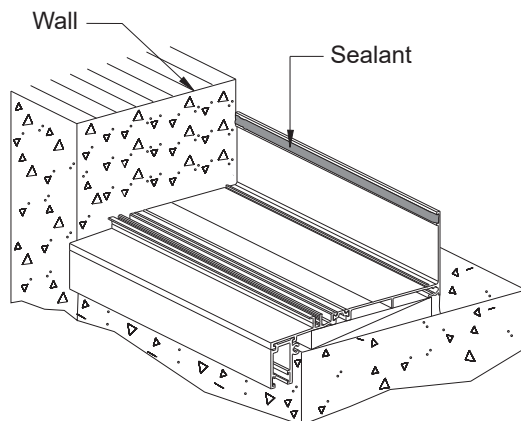

DETAIL 45

FRAME INSTALLATION

STEP 26 (Continued)

INSTALL ASSEMBLED FRAMES WITH SLAB EDGE COVER

- Set unglazed YWW 50 T frame into the opening pressing the excess sealant out of the sealant track on the sill flashing.
- Clean up excess sealant.
- Apply receptor snap cover into head receptor.
- Match drill hole in sill flashing for PM-1006-SS and install screws.

See **Detail 46**.

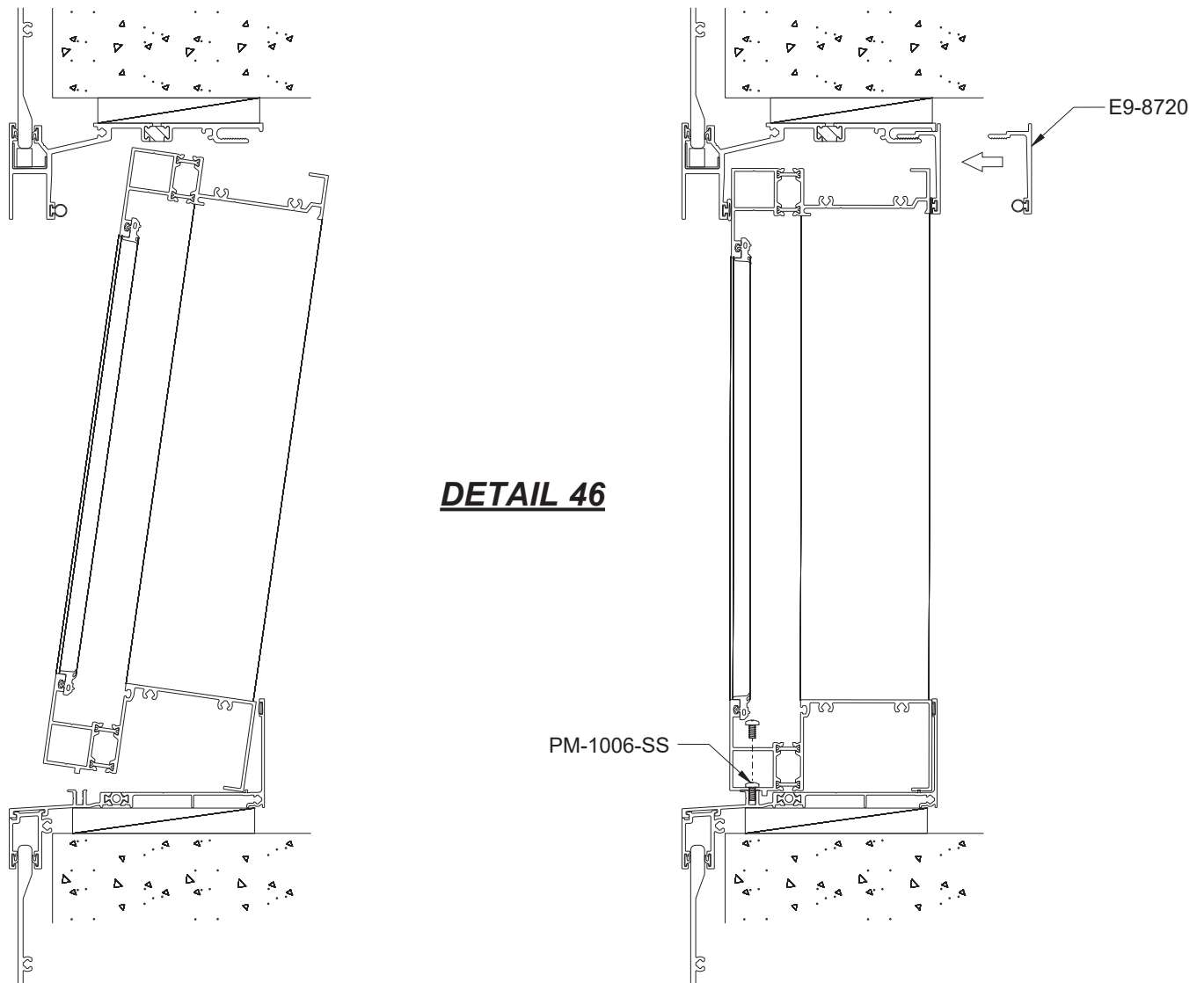

FRAME INSTALLATION

STEP 27

APPLY PERIMETER SEALANT

- Install backer rod and apply sealant to the back of the sill flashing and head receptor.
- Tool sealant prior to skinning over. See **Detail 47**.
- Also apply and tool sealant to the splice joint between the slab edge cover plates. See **Detail 47A**.

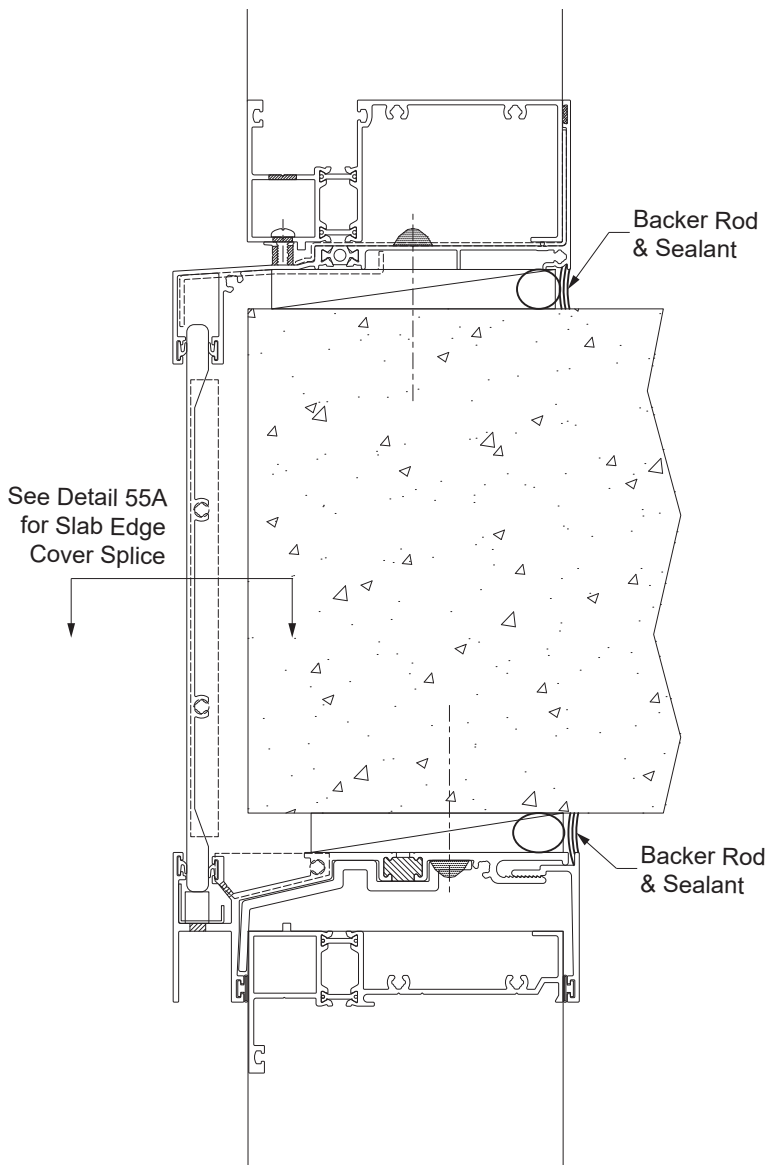

DETAIL 47
(WITH SLAB EDGE COVER)

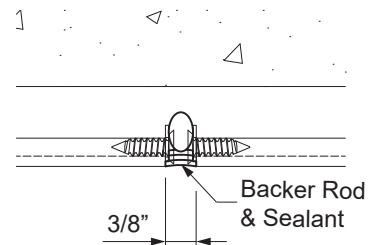

DETAIL 47A
(WITH SLAB EDGE COVER)

FRAME INSTALLATION

STEP 27 Continued)
APPLY PERIMETER SEALANT

- Install backer rod and apply sealant to the back of the sill flashing and head receptor.
- Tool sealant prior to skinning over.

See **Detail 48**.

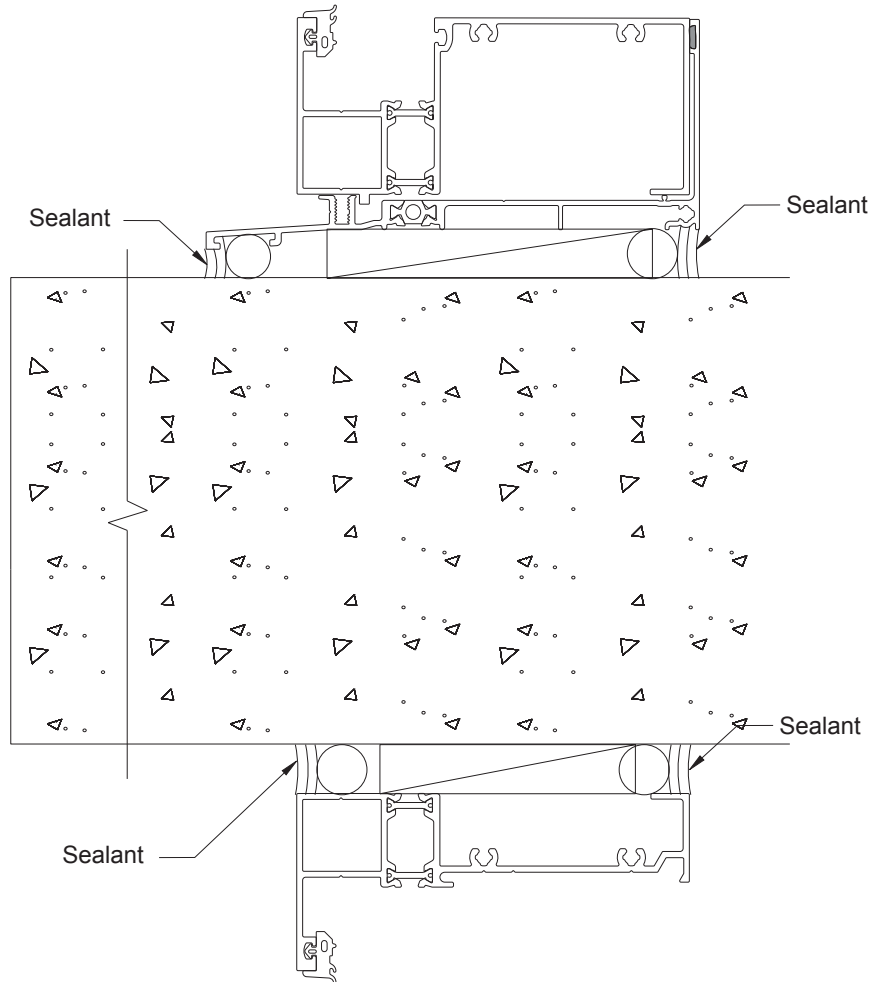

DETAIL 48
(WITHOUT SLAB EDGE COVER)

FRAME INSTALLATION

STEP 28 INSTALL WATER DEFLECTORS (Standard Mullions and Jamb)

The installation of a water deflector, E2-0047, at the ends of every intermediate horizontal is required to divert water away from the insulated units.

- Clean and dry off the glazing pocket of each horizontal at the ends.
- Peel off the protective paper and install the water deflector at the end of the horizontal.
- Position the vertical leg of the deflector against the end of the horizontal.
- Apply and tool sealant along the edges of the water deflector down onto the horizontal.
- Seal the ramp of the water deflector to the sides of the glazing pocket wall.

See **Detail 49**.

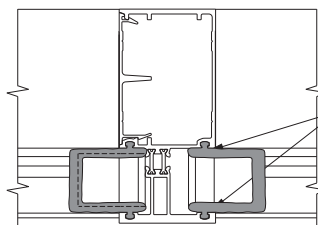
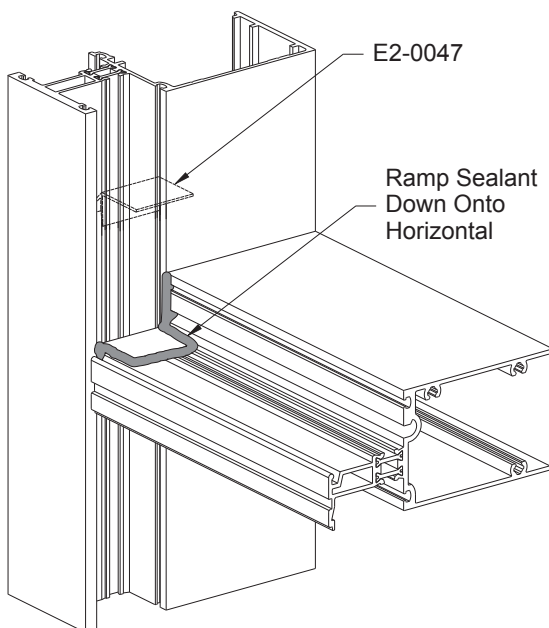

Seal Ramp of Deflector to the Pocket Wall

DETAIL 49

Outside Glazed Shown
Inside Glazed Similar

STEP 29 INSTALL HORIZONTAL BRIDGES (For SSG Verticals Only)

The installation of horizontal bridge, E1-1038, is required to bridge the gap between intermediate horizontals at the SSG vertical.

- Clean and dry off the glazing pocket of each horizontal at the ends.
- Install E1-1038 from the underside of the horizontals with a PC-1006 fastener on each side.
- Fill the cavity of the horizontal with backer rod and completely cover the end of the horizontals with sealant.
- Apply and tool sealant at all bridge to horizontal and vertical joints to ensure a watertight seal.

See **Detail 50**.

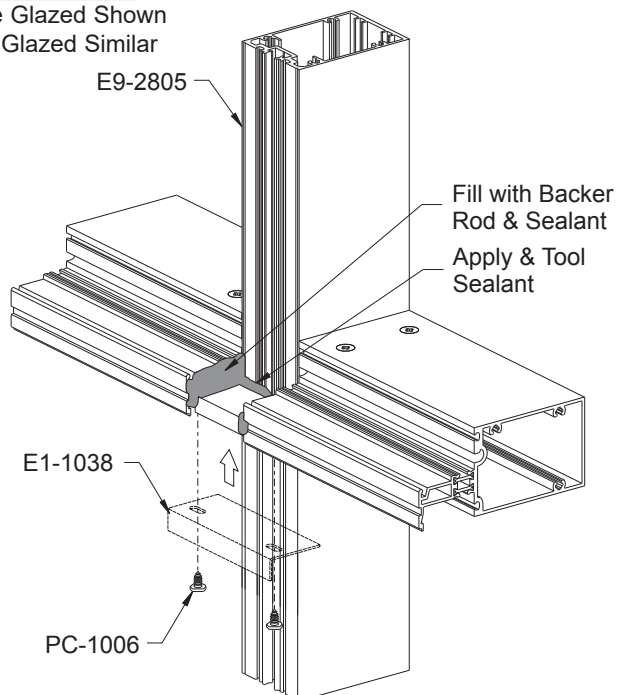

DETAIL 50

FRAME INSTALLATION

STEP 29 (Continued)

INSTALL HORIZONTAL BRIDGES (For SSG Verticals Only)

The installation of horizontal bridge, E1-1039, is required to bridge the gap between intermediate horizontals at the SSG corner.

-Clean and dry off the glazing pocket of each horizontal at the ends.

-Install E1-1039 from the underside of the horizontals with a PC-1006 fastener on each side.

See **Detail 51**.

-Fill the cavity of the horizontal with backer rod and completely cover the end of the horizontals with sealant.

-Apply and tool sealant at all bridge to horizontal and vertical joints to ensure a watertight seal.

See **Detail 52**.

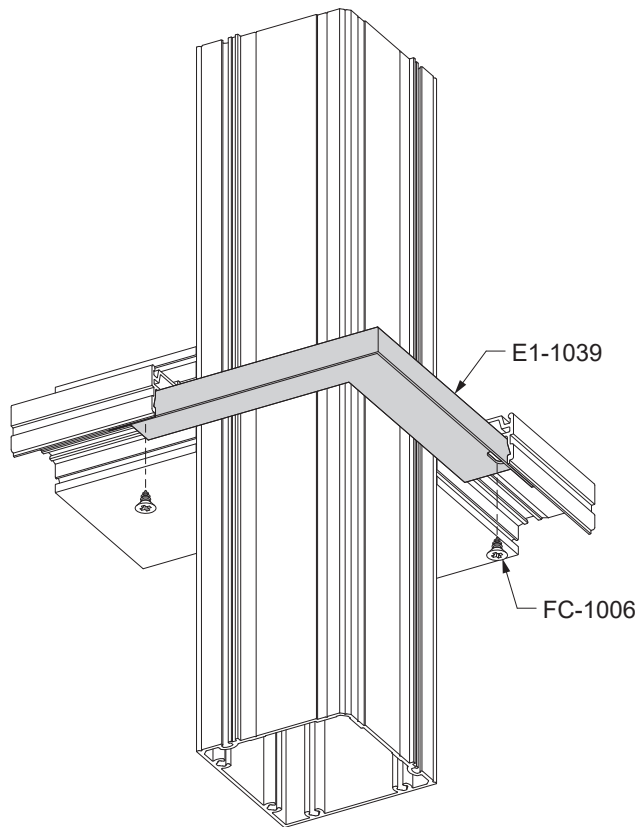

DETAIL 51

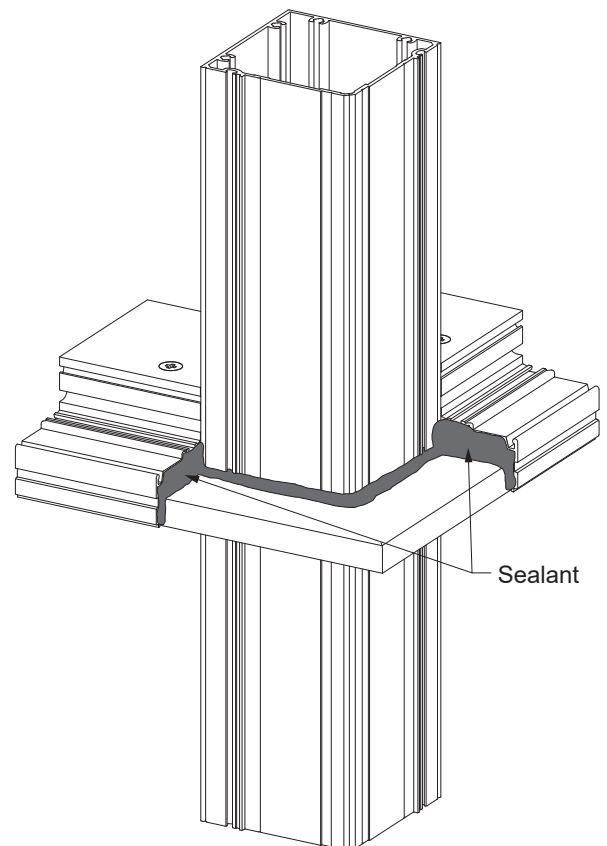

DETAIL 52

FRAME INSTALLATION

**STEP 30
INSTALL CORNER TRIM AT 90° OUTSIDE SSG CORNER**

- Cut the E9-2550 90° Outside Trim Cover Base and E9-3439 Trim Cover to Daylight Opening (D.L.O.H.) plus (+) 1".
- Mark hole locations on the trim cover no more than 3" from each end and then 18" on center maximum on both sides along the "V"-groove. Drill 0.189" diameter holes at each hole location. See **Detail 53**.
- For application at the continuous head or sill, notch 1/2" x 1/2" from the ends of the legs of the E9-2550 corner mullion trim adaptor base as shown in **Detail 53**. Drill 0.189" diameter clear holes in the legs of the adaptor 2" from each end and at 18" on center. Apply sealant to the legs of the trim adaptor prior to fastening to the corner mullion

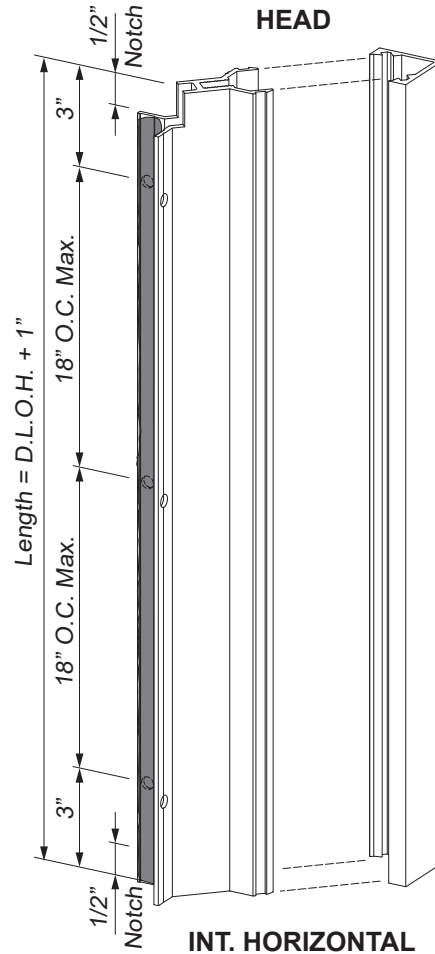
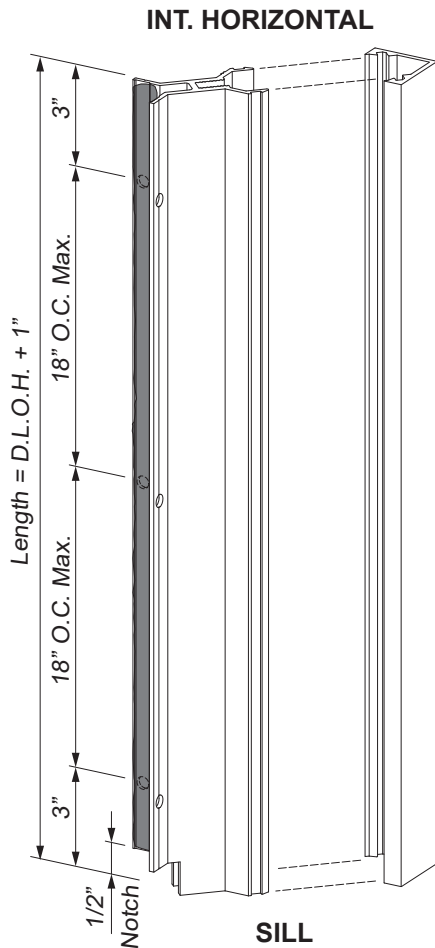
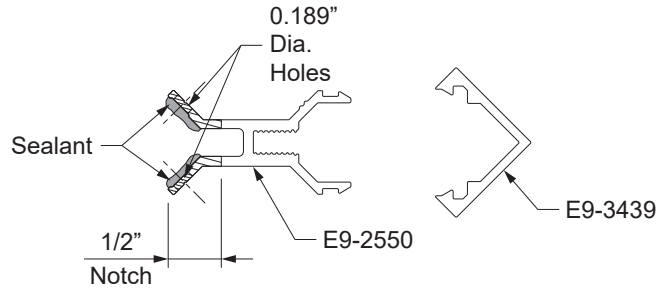

DETAIL 53

FRAME INSTALLATION

STEP 30 (Continued)

INSTALL CORNER TRIM AT 90° OUTSIDE SSG CORNER

- Position the trim cover onto the corner mullion centered along the vertical daylight opening and match drill 0.141" diameter holes into the mullion.
 - Attach the corner trim base to the corner mullion with PC-0806 fasteners. Do not attach the trim cover at this time.
 - Apply and tool sealant to all screw heads.
- See **Detail 54**.

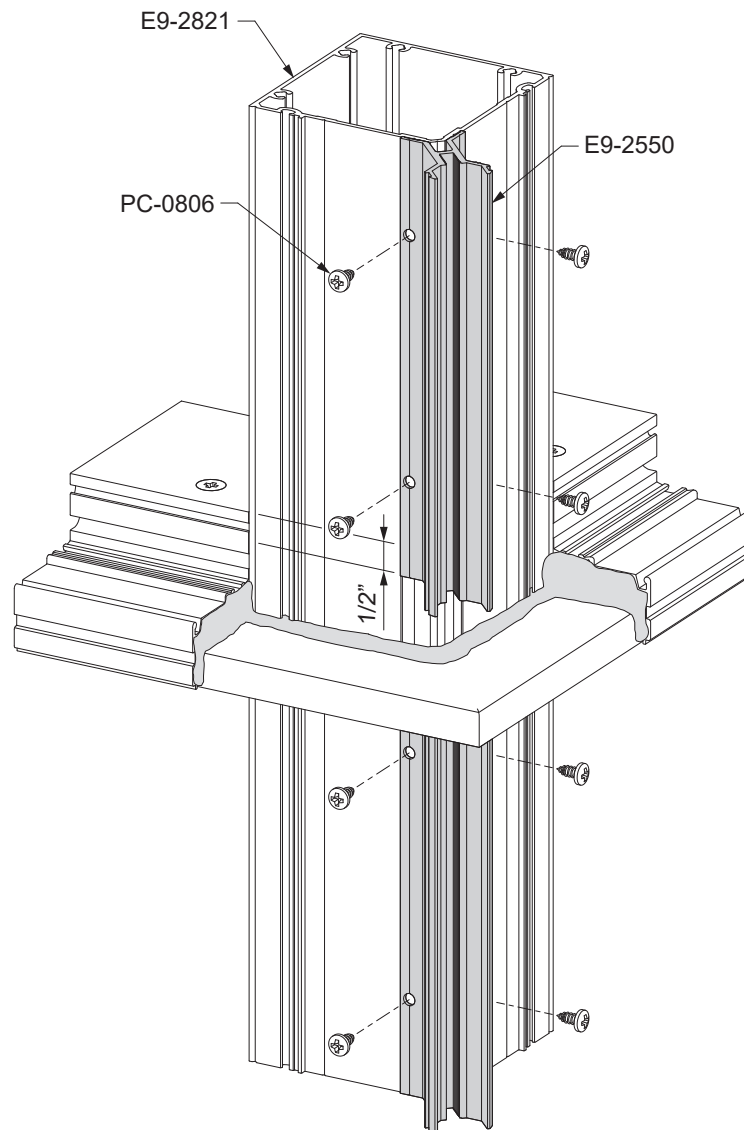

DETAIL 54

FRAME INSTALLATION

STEP 31 INSTALL 1/4" GLAZING ADAPTORS (When Required)

Attach the vertical glazing adaptors first.

For Standard Verticals:

- Apply sealant in the vertical gasket reglets.
- Center the vertical adaptor in the opening.
- Position the foot of the adaptor into the MegaTherm recess and rotate the other end into the gasket reglet of the mullion.

For SSG Verticals:

- Center the vertical adaptor in the opening.
- Attach the SSG glazing adaptor, E9-2716, to the mullion with PC-1010 fasteners, 2" from each end and no more than 18" on center.
- Seal all screw heads.

See **Detail 55**.

Attach the horizontal glazing adaptors last.

- Apply sealant to the ends of the horizontal glazing adaptors.
- Install the horizontal adaptors.

-Tool the sealant at the intersections of the adaptors to completely seal the joint.

See **Detail 56**.

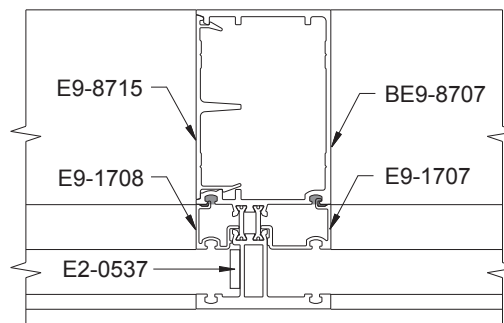

Standard Vertical

DETAIL 55

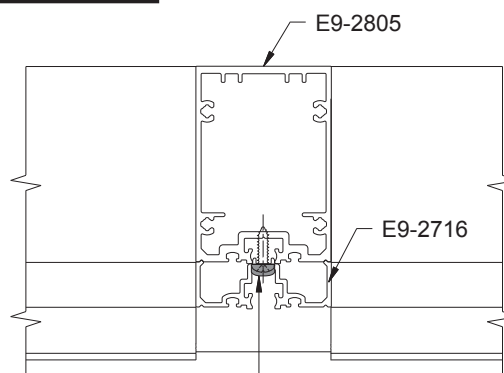

SSG Vertical

Seal All
Screw Heads
(PC-1010)

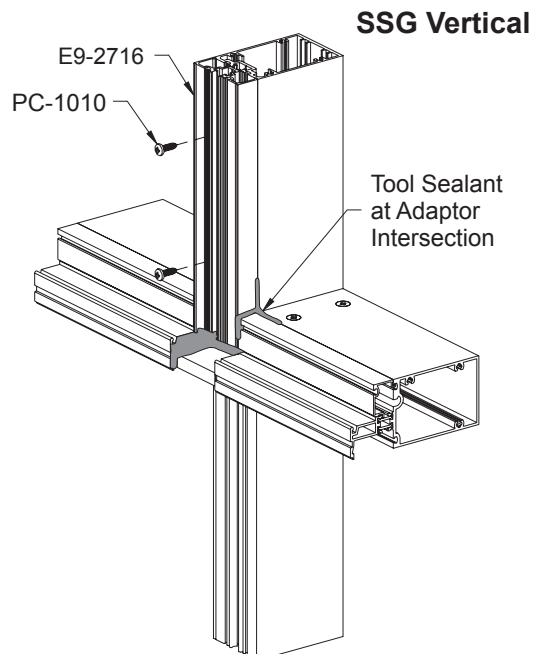
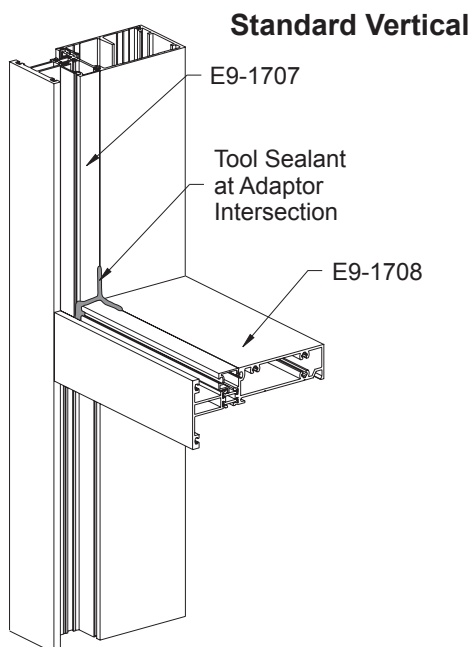

DETAIL 56

GLAZING

STEP 32 SEAL INSIDE GLAZED HORIZONTALS

Note: For Outside Glazing, skip this step and proceed to **Step 33** on **Page 47**.

Before installing the gaskets on an inside glazed window wall, the horizontals must be sealed to the verticals at the face of the system from the inside as shown in **Detail 57**.

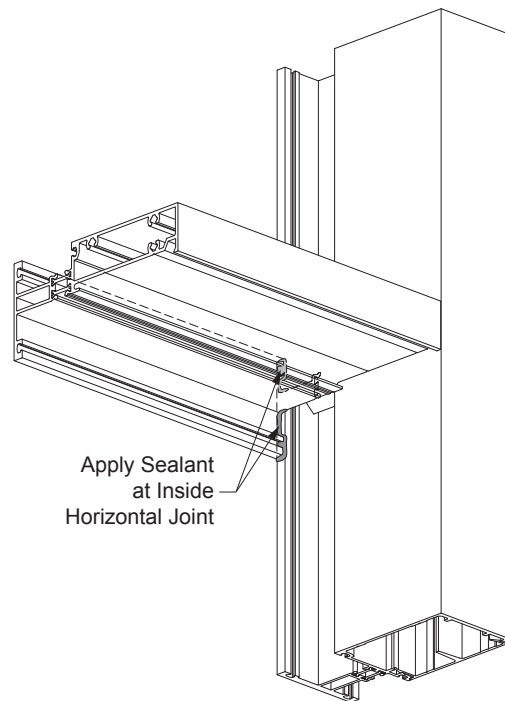

DETAIL 57
Inside Glazed Shown

GLAZING

STEP 33 INSTALL PUSH IN GLAZING GASKETS

For inside glazing: Push-in gasket, E2-0801, must be installed on the exterior prior to glazing.
For outside glazing: Push-in gasket, E2-0801, must be installed on the interior prior to glazing.

-Using a small brush clean out any dirt that may have accumulated in the gasket reglets.

Vertical glazing gaskets must be installed first:

- Cut vertical glazing gaskets to the Daylight Opening plus(+) 3/4" plus(+) an additional 1/4" for each foot of length. Notch ends of the vertical gasket as shown.
- Insert the gasket into the reglets at each end first; then insert the gasket at the midpoint of the opening.
- Push the gasket into the reglet starting at the midpoint and work towards each end.

See **Detail 58**.

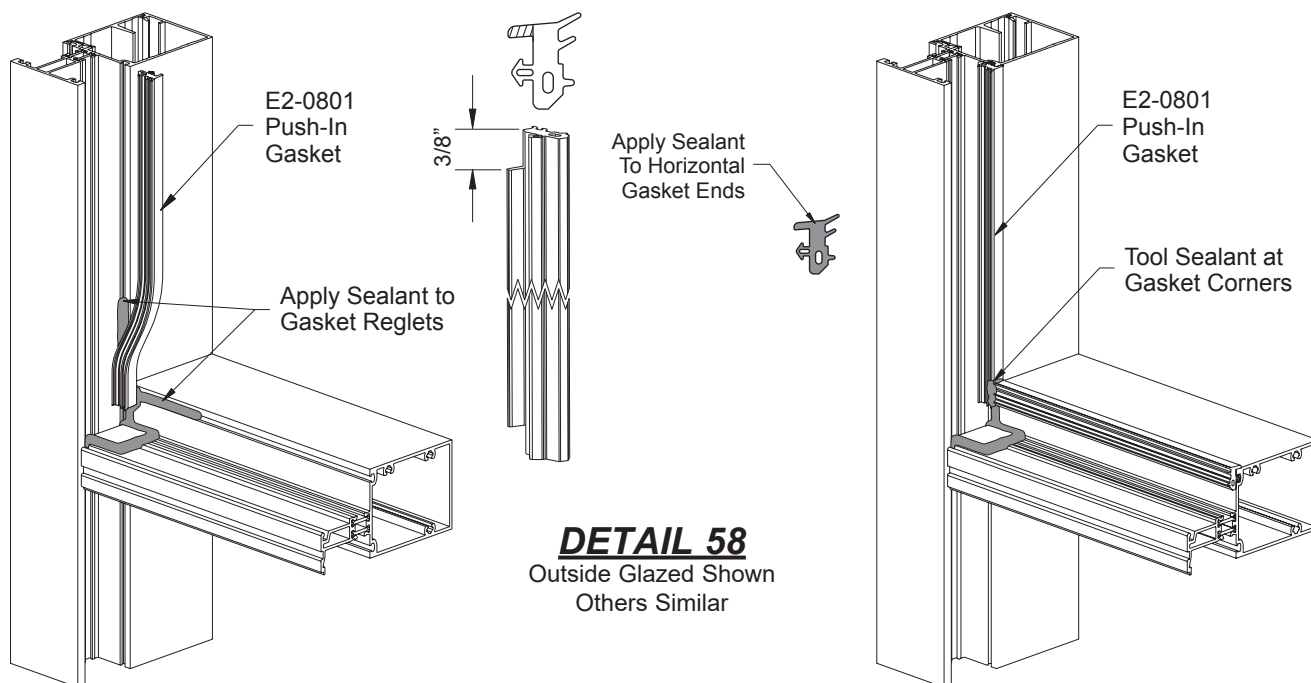

DETAIL 58
 Outside Glazed Shown
 Others Similar

Install horizontal glazing gaskets next:

- Cut horizontal glazing gaskets to Daylight Opening plus(+) 1/4" for each foot of length.
- Apply sealant to each end of the horizontal glazing gasket prior to inserting into the reglet.
- Insert the gasket into the reglet at each end first; then insert the gasket at the midpoint of the opening.
- Push the gasket into the reglet starting at the midpoint and work towards each end.
- Tool the excess sealant at the gasket corners to ensure a watertight seal.

See **Detail 58**.

-See **Step 35** on **Page 52** for SSG gasket instructions.

GLAZING

STEP 34
INSTALL GLASS FOR STANDARD GLAZING

Determine the glass size:

	Width	Height
Standard Glazing	D.L.O. + 7/8"	D.L.O. + 7/8"

- Install setting blocks at 1/4 points or according to engineering calculations.
At intermediate horizontals: E2-0184 for 1" glazing and E2-0192 for 1/4" glazing.
At sill conditions: E2-0182 for 1" glazing and E2-0190 for 1/4" glazing.

See **Detail 59**.

- Install side blocks, E2-0186, in the shallow glazing pocket of each vertical at the midpoint of daylight opening.
- Carefully install glass into the frame making sure that setting and side blocks are properly aligned with the glass.

Note: Be careful not to disengage any gaskets that have already been installed when installing glass.

See **Details 59 & 60**.

After glass is set, install one (1) E2-0153 anti-walk block at the deep pocket mullion locations.

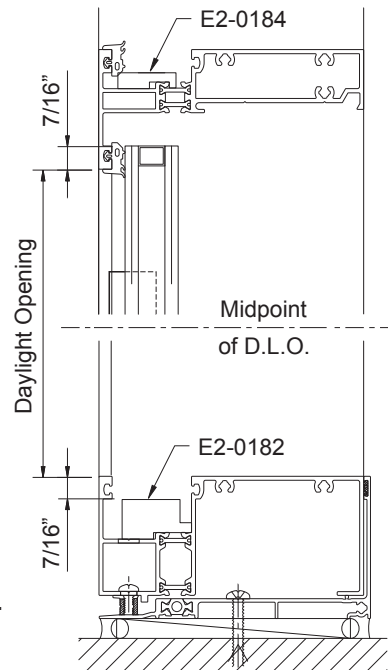

DETAIL 59

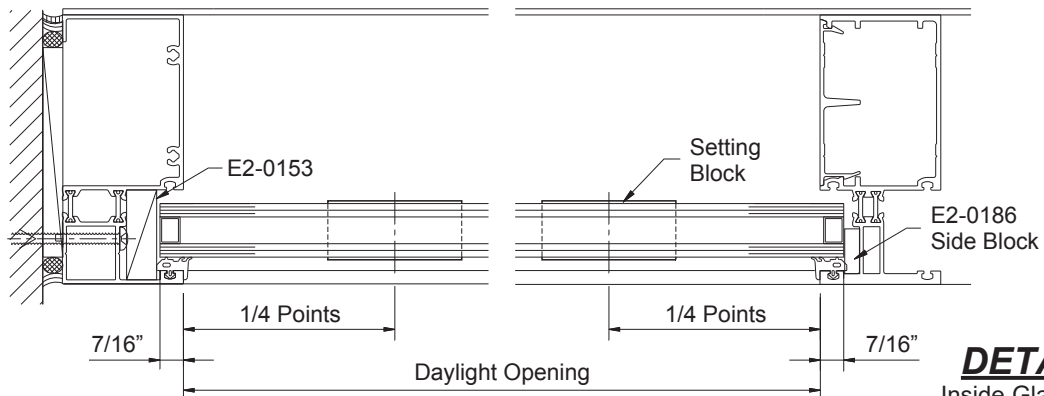

DETAIL 60
Inside Glazed Shown
Others Similar

GLAZING

**STEP 34 (Continued)
INSTALL GLASS FOR STANDARD GLAZING**

For Interior Glazing:

Interior glass stops are required at all head and intermediate horizontals:

- E9-8711 for 1" glazing and
- E9-7703 for 1/4" glazing.

-Apply sealant to each end of the glass stops and snap them into position.

-Tool the sealant into the joint between the glass stop and the vertical to ensure a watertight seal and wipe away any excess sealant.

See **Detail 61**.

-Install the interior horizontal wedge gaskets, E2-0808, to the Daylight Opening plus(+) 1/4" for each foot of length, leaving the ends out until the vertical gasket is installed.

-Cut the vertical wedge gasket to vertical Daylight Opening plus (+) 3/4". Notch the ends of the gasket as shown in **Detail 62**.

-Insert the vertical gasket into the glazing pocket, pushing the notched ends into the horizontals.

-Apply sealant to the ends of the horizontal wedge gaskets and finish inserting them into the glazing pocket against the vertical wedge gaskets.

See **Detail 63**.

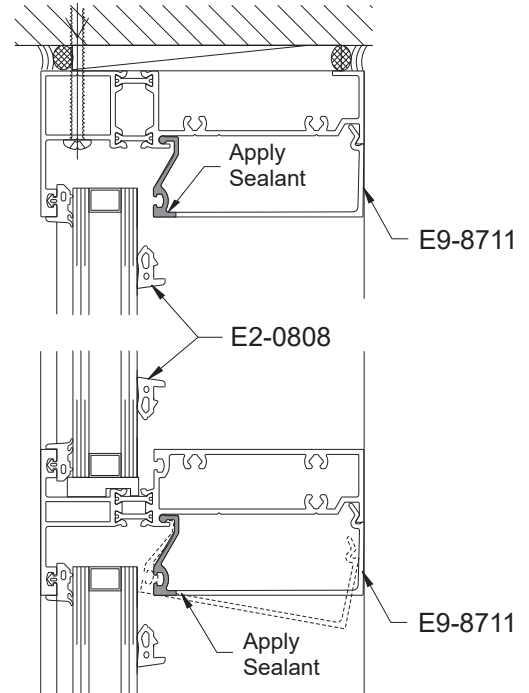

DETAIL 61

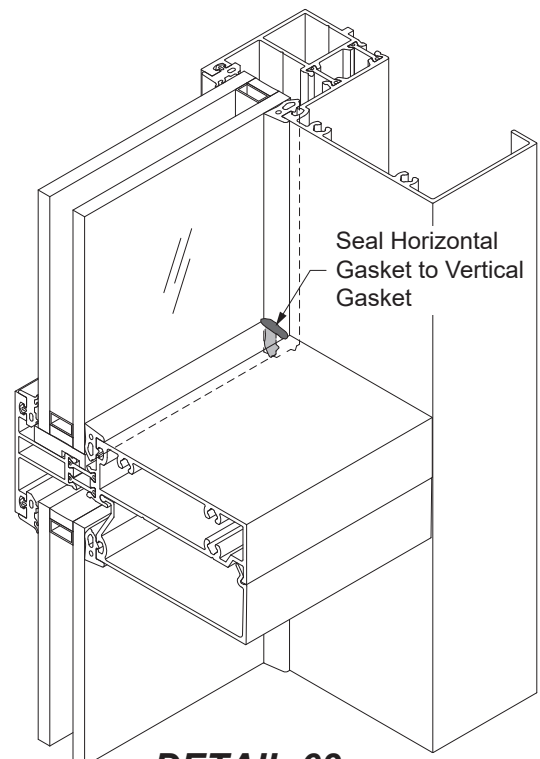

DETAIL 63
Inside Glazing

DETAIL 62

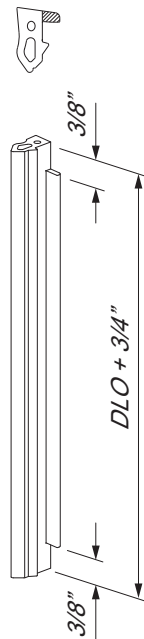

GLAZING

STEP 34 (Continued) INSTALL GLASS FOR STANDARD GLAZING

For Outside Glazing:

Exterior face covers are required at all sill and intermediate horizontals:

E9-1715 for BE9-2823 horizontal members.

-Apply sealant to the ends of the face covers, and engage the hook of the face covers with the ball of the horizontal members and rotate them into position.

See **Detail 64**.

-Install the exterior horizontal wedge gaskets, E2-0808, to the Daylight Opening plus(+) 1/4" for each foot of length, leaving the ends out until the vertical gasket is installed.

-Cut the vertical wedge gasket to vertical Daylight Opening plus (+) 3/4". Notch the ends of the gasket as previously shown in **Detail 62**.

-Insert the vertical gasket into the glazing pocket, pushing the notched ends into the horizontals.

-Apply sealant to the ends of the horizontal wedge gaskets and finish inserting them into the glazing pocket against the vertical wedge gaskets.

See **Detail 65**.

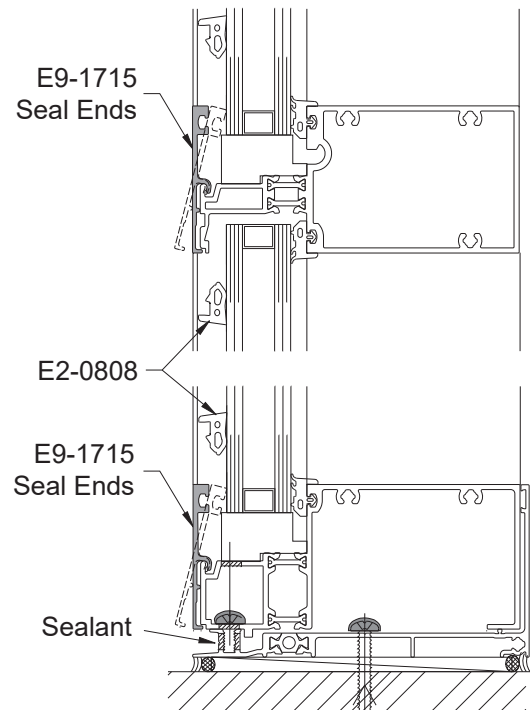

DETAIL 64

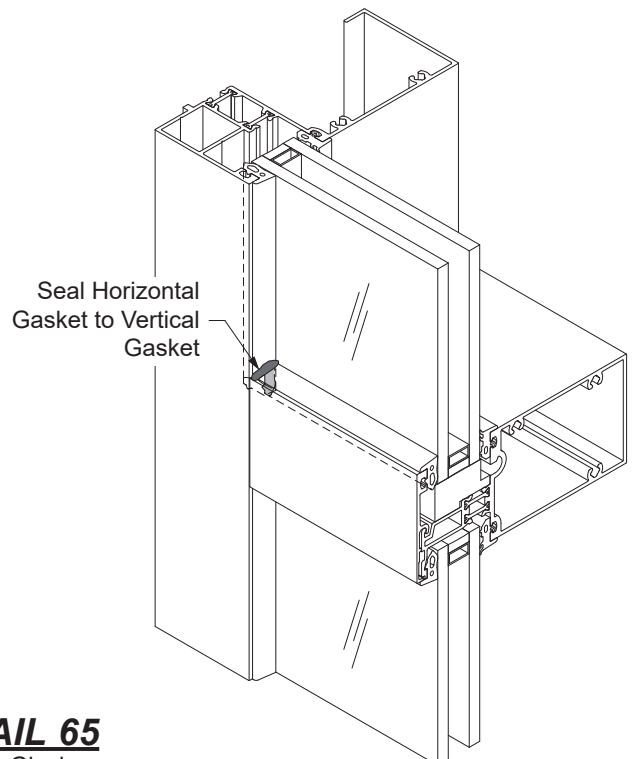

DETAIL 65
Outside Glazing

GLAZING

STEP 35 INSTALL GLASS FOR STRUCTURAL SILICONE GLAZING

Determine the glass size:

	Width	Height
Jamb to SSG	D.L.O. + 1-5/16"	D.L.O. + 7/8"
SSG to SSG	D.L.O. + 1-3/4"	D.L.O. + 7/8"

-Install setting blocks at 1/4 points or according to engineering calculations.

At intermediate horizontals: E2-0184 for 1" glazing and E2-0192 for 1/4" glazing.

At sill conditions: E2-0182 for 1" glazing and E2-0190 for 1/4" glazing.

See **Detail 66**.

-Cut glazing spacer, E2-0544, to the Daylight Opening.

-Install the glazing spacer as shown in **Detail 63**.

-Install the interior glazing gaskets at the jambs and horizontals as shown in **Step 34** on **Page 49**.

-Carefully install each lite of glass leaving a 1/2" joint between lites of glass. Be careful not to disturb the interior gaskets and spacers.

-Insert the temporary glass retainers, E3-0001 for 1" glazing or E3-0006 for 1/4" glazing, between the lites and twist them 90° clockwise to engage.

-Locate temporary glass retainers 18" to 24" on center.

-Snap on exterior face covers and install exterior wedge gaskets, E2-0542, starting at one end and work towards the opposite end. Seal the ends of the horizontal wedge gasket to the vertical gasket at the jamb.

See **Detail 67**.

Determine the gasket size:

Jamb	D.L.O. + 3/4", notched at ends
Spacer	D.L.O.
Head/Sill	D.L.O. + 1/4" per Foot of D.L.O.

Notch head/sill gaskets as shown on **Page 49**. Notch jamb gaskets as shown on **Page 51**.

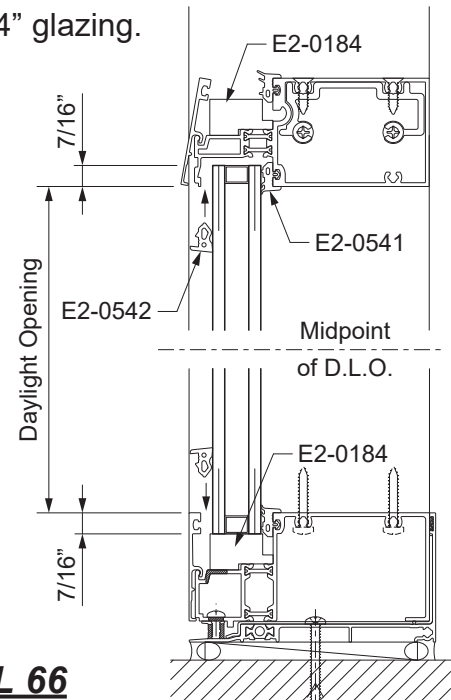

DETAIL 66

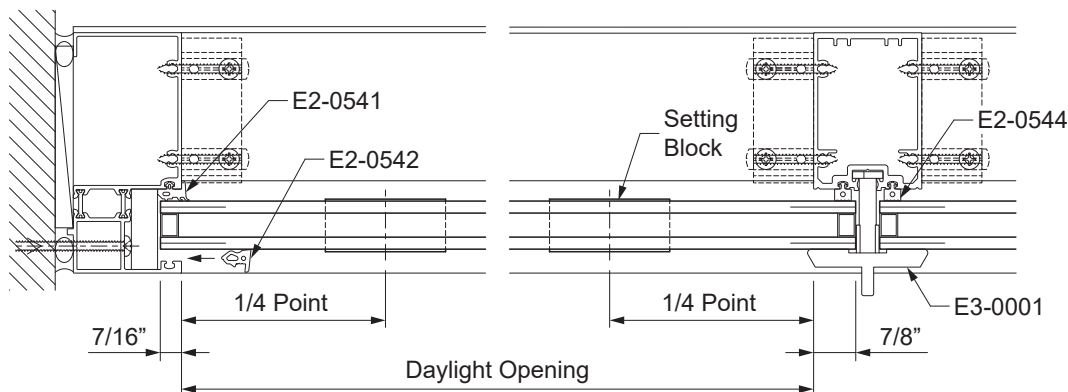

DETAIL 67

GLAZING

STEP 35 (Continued)

INSTALL GLASS FOR STRUCTURAL SILICONE GLAZING

-At the 90° corner SSG mullions, use E1-3588 retainers with HM-2516 fasteners, spaced at 2'-0" maximum on center.

See **Detail 68**.

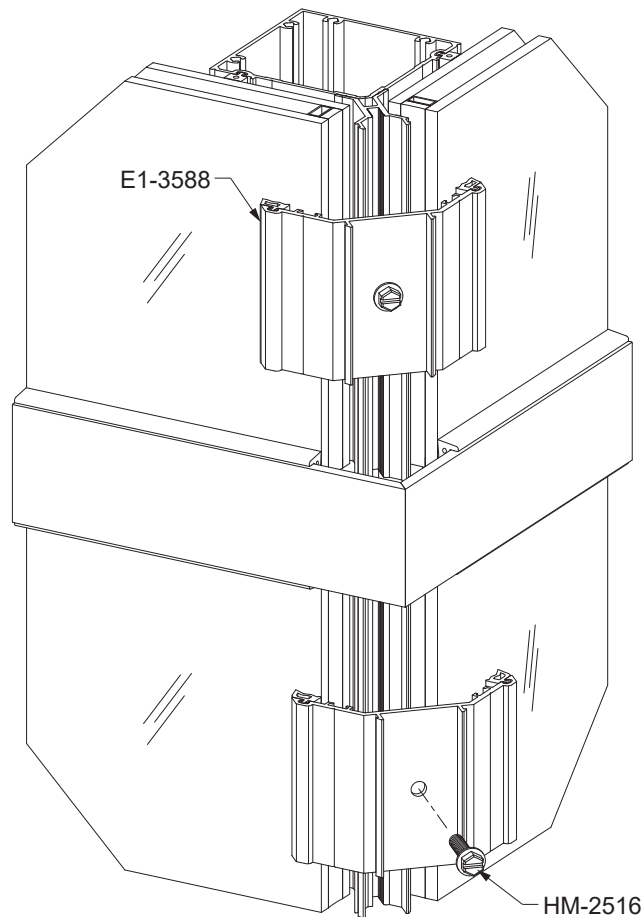

DETAIL 68

GLAZING

STEP 35 (Continued) INSTALL GLASS FOR STRUCTURAL SILICONE GLAZING

Apply Interior Structural Silicone:

- Prior to applying structural silicone, clean all contact surfaces using an approved cleaner.
- Run masking tape vertically on the glass with one edge in line with the side of the mullion.
- Run another piece of masking tape vertically along the edge of the vertical next to the glass.

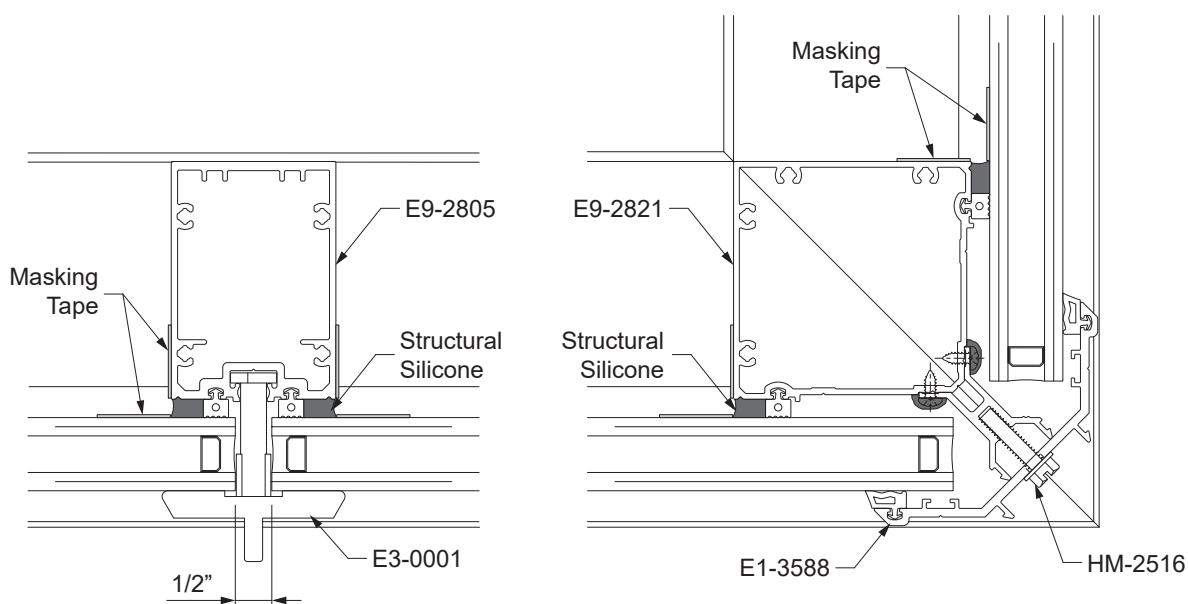

DETAIL 69

- Apply an approved structural silicone from the bottom to the top of the joint. Use positive pressure to completely fill the cavity between the glass and vertical mullion.
 - Using a nylon spatula or other non-scratching implement, tool the silicone immediately after running the vertical joint. Exert positive pressure while tooling to ensure that the silicone completely fills the cavity.
 - Be careful not to remove too much silicone. The silicone should make complete contact with the glass and aluminum surfaces. The finished joint should be flush with the edge of the vertical.
- See **Detail 69**.

Caution: Do not permit the silicone to skin over before it is tooled. Immediately remove masking tape after tooling the silicone.

GLAZING

STEP 35 (Continued)

INSTALL GLASS FOR STRUCTURAL SILICONE GLAZING

Apply Exterior Weatherseal:

Interior structural silicone must be fully cured before removing temporary retainers. Please consult sealant manufacturer for recommended cure time.

- Remove the temporary glass retainers and insert a backer rod between the lites of glass.
- Clean all contact surfaces with an approved cleaner and apply masking tape to both vertical edges of the glass.
- Starting at the bottom of the lite, pump silicone into the joint between the lites of glass. Apply moderate pressure so that the void is completely filled, and tool.

Caution: Be careful not to puncture the backer rod or push it out of the way.

DETAIL 70

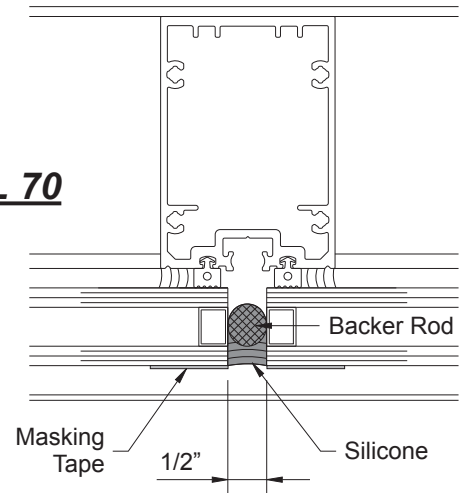

See **Detail 70**.

- At face cover splices, carry the sealant down over the face cover without sealing off the bottom to allow the system to weep properly.
- See **Detail 71**.

- Using a nylon spatula or other non-scratching implement, tool the silicone immediately after running the vertical joint. Exert positive pressure while tooling to ensure that the silicone completely fills the cavity.
- Be careful not to remove too much silicone. The silicone should make complete contact with the glass and aluminum surfaces. The finished joint should be flush with the edge of the vertical.

DETAIL 71

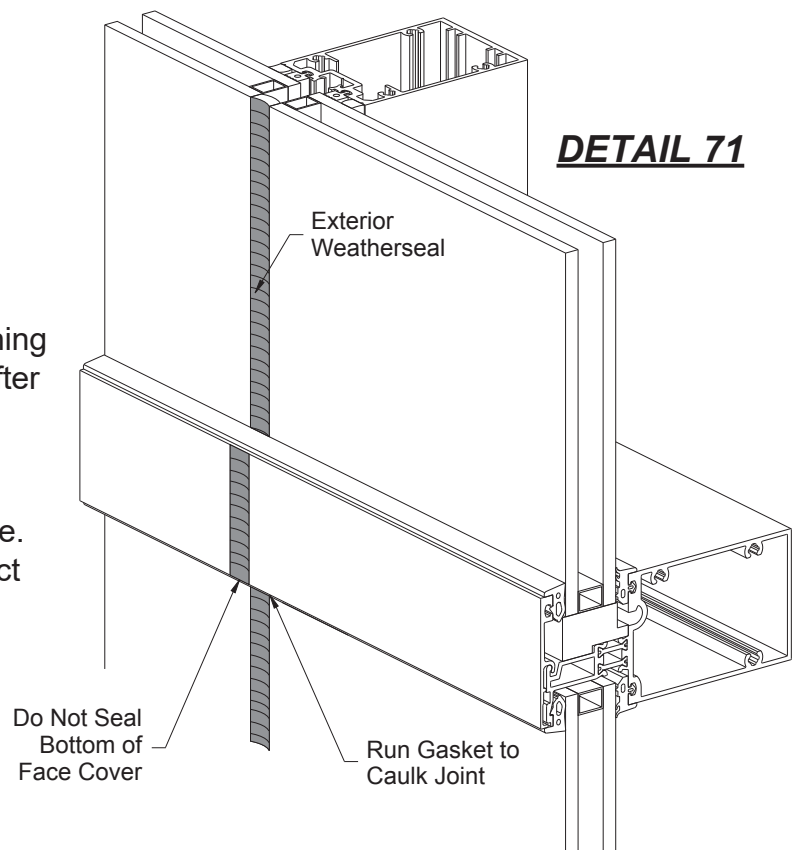

Caution: Do not permit the silicone to skin over before it is tooled. Immediately remove masking tape after tooling the silicone.

GLAZING**STEP 35 (Continued)****APPLY FACE COVER SEAL AT 90° OUTSIDE SSG CORNERS**

- Install exterior glazing gaskets and snap on face covers to the horizontal members at the SSG corner as previously shown in this manual.
- After glass is installed and exterior weatherseal is applied, apply a bead of sealant at the intermediate horizontal and sill along the top of the face cover gasket from weatherseal to weatherseal at the corner mullion.
- Tool the sealant to form a complete seal at the SSG corners.

See **Detail 72**.

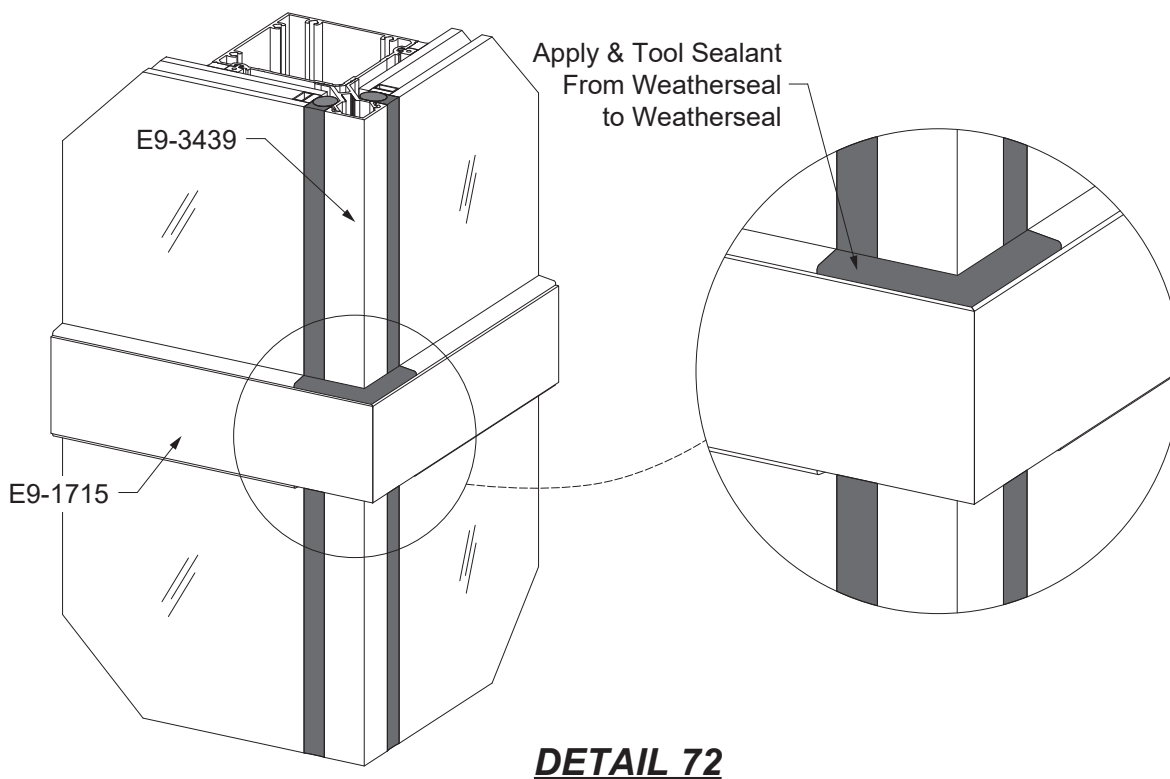



101 Marietta Street NW
Suite 2100
Atlanta, Georgia 30303
www.ykkap.com