

YWE 60 T Window Wall System

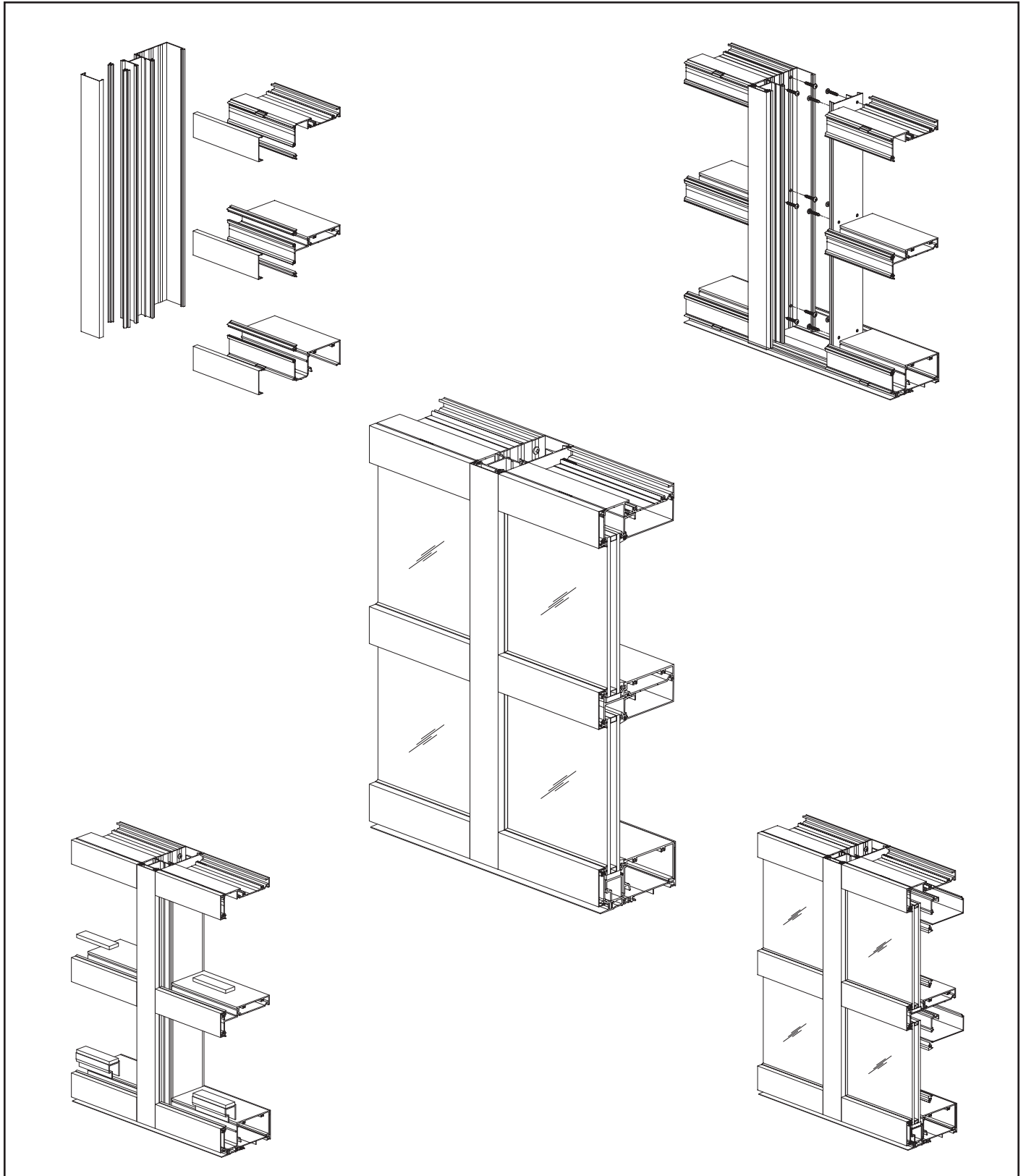

Installation Manual

TABLE OF CONTENTS

Installation Notes	Page ii
Frame Types	Pages iii & iv
PARTS DESCRIPTION	
YWE 60T Framing Members	Pages 1 & 2
YWE 60T Accessories	Pages 3 & 4
FRAME FABRICATION	
Determine Frame Size	Page 5
Fabricate Sill Flashing	Page 6
Fabricate Head and Sill Members	Pages 6 & 7
Fabricate Intermediate Horizontals	Page 8
Fabricate Vertical Mullions	Pages 8 & 9
Fabricate Glass Stops and Interior Trim Covers	Page 10
Fabricate Face Covers	Page 10
ASSEMBLY	
Attach Mullion End Caps & End Dams	Page 11
Attach Face Covers	Page 12
Assemble Frames	Page 13 & 14
FRAME INSTALLATION	
Install Sill Flashing	Pages 15 to 16
Sill Preparation	Page 17
Install Sill Flashing at Corners	Page 18
Install Assembled Frames	Page 19
Using Optional Head and Sill Anchors	Pages 20 & 21
Seal the Frames	Page 22
Install Water Deflectors	Page 23
Install Horizontal Bridge and Face Covers for SSG	Pages 23 & 24
Apply Perimeter Sealant	Page 25
Install 1/4" Glazing Adaptors	Page 26 & 27
GLAZING	
Install Glass for Standard Glazing	Pages 28 & 29
Install Glass for Structural Silicone Glazing	Pages 30 to 33
Reglazing Instructions	Page 34
CORNER CONDITIONS	
Install Standard Corner Mullions	Pages 35 & 36
Install 90° SSG Corner Mullions	Pages 37 to 42
DOOR CONDITIONS	
Door Installation	Pages 43 to 47

Installation Notes

1. Do not drop, roll or drag boxes of aluminum framing. Move and stack boxes with proper support to prevent distortion. If fork lifts are used be especially careful about striking the boxes when lifting or moving.
2. Store in a dry, out of the way area. If rain exposure, condensation or any water contact is likely, then all packaging material should be removed. Wet packaging materials will discolor and may stain aluminum finishes and paints.
3. All materials should be checked for quantity and quality upon receipt, YKK AP must be notified immediately of any discrepancies in shipment. Check to make sure that you have the required shims, sealants, supplies and tools necessary for the installation.
4. Carefully check the openings and surrounding conditions that will receive your material. Remember, if the construction is not per the construction documents, it is your responsibility to notify the general contractor in writing. Any discrepancies must be brought to the general contractor's attention before you proceed with the installation.
5. Gather your shop drawings, materials, packing list and this installation manual. Carefully review parts location, the sequence it goes therein when you glaze it and how you seal it. Installation instructions are of a general nature and may not cover every condition you encounter. The shop drawings and/or installation manuals were prepared specifically for the product.
6. Any material substitutions must be of equal or greater quality.
7. Make certain that material samples have been sent for compatibility testing for all manufacturer's sealants involved. Make certain that sealants have been installed in strict accordance with the manufacturer's recommendations and specifications.
8. Remember to isolate, in an approved manner, all aluminum from uncured masonry or other incompatible materials.
9. System-to-structure fasteners are not supplied by YKK AP. Fasteners called out on shop drawings are to indicate minimum sizes for design loading.
10. Entrances are to be installed plumb, square, level and true.
11. If any questions arise concerning YKK AP products or their installation, contact YKK AP for clarification before proceeding.
12. YKK AP store front and/or curtain wall framing is typically completed before drywall, flooring and other products that may still be in process. Take the extra time to wrap and protect work produced.
13. Cutting tolerances are plus zero, minus one thirty second unless otherwise noted.
14. Check our website, www.ykkap.com, for the latest installation manual update prior to commencing work.



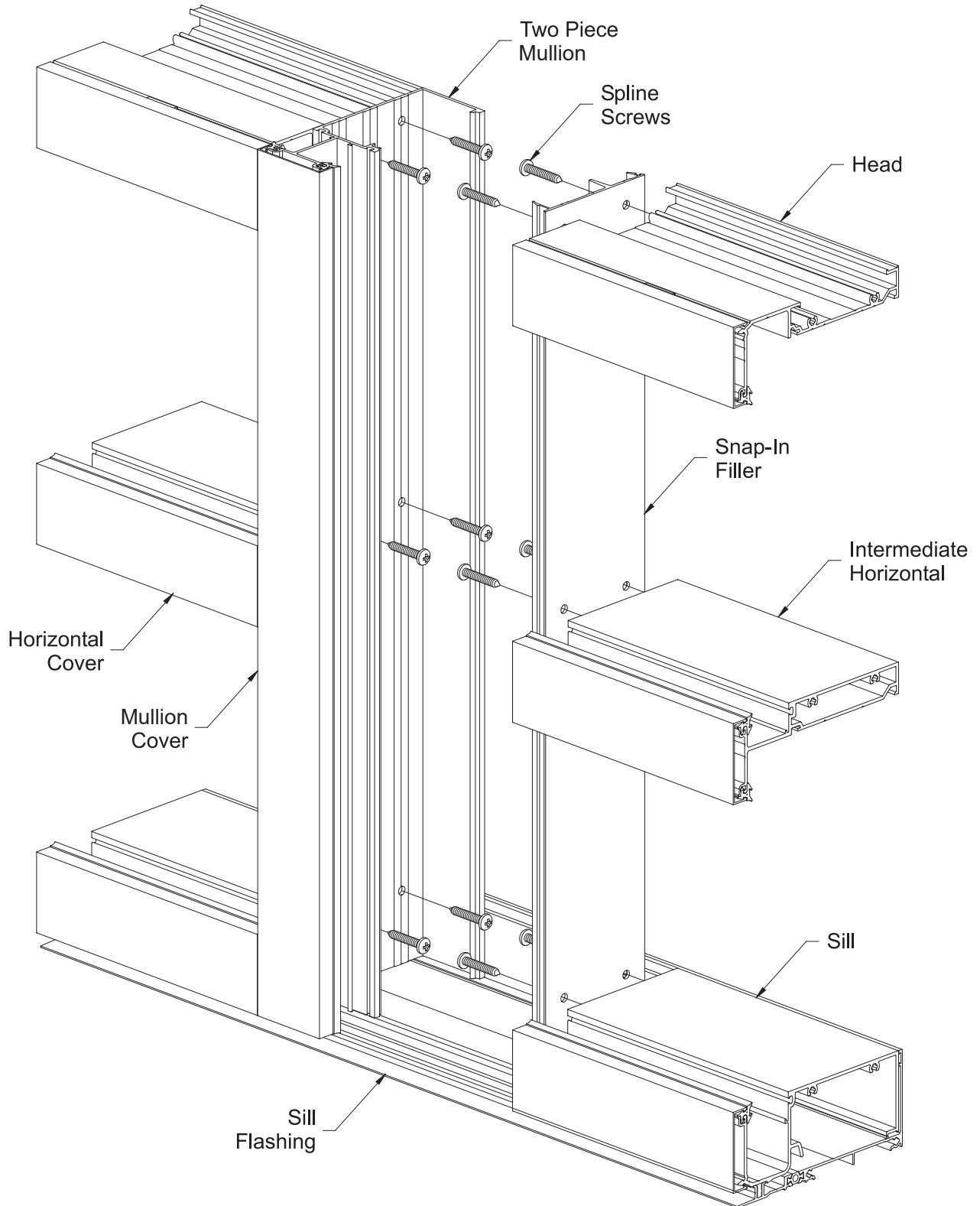



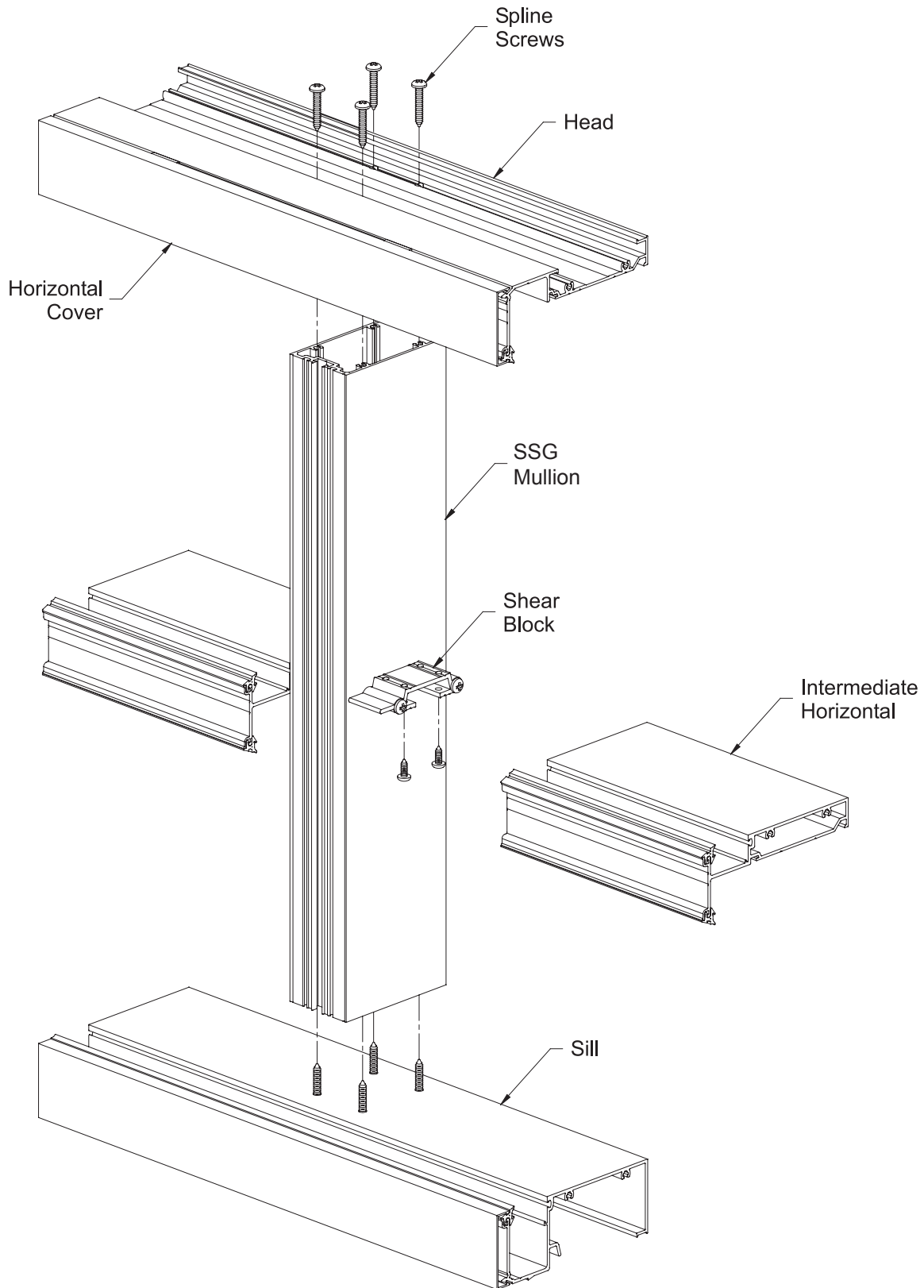





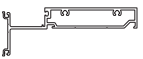

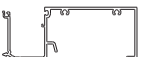





FRAME TYPES Mullion Through Frame





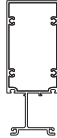
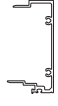



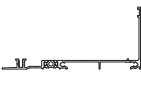







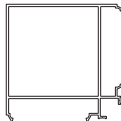



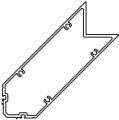

FRAME TYPES
Continuous Head and Sill Frame (Frames 24'-0" or Smaller)







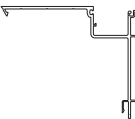

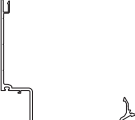



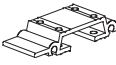
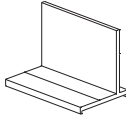

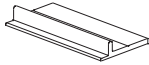
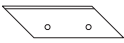
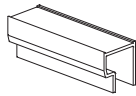
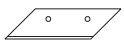
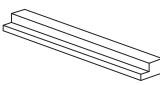
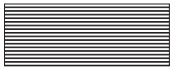
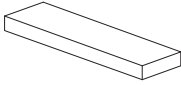
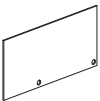
FRAMING MEMBERS

 Head 2-1/4" x 6"	E9-2301	 1/4" Glazing Adaptor	E9-2340
 Horizontal 2-1/4" x 6"	E9-2302	 1/4" SSG Glazing Adaptor Use with E9-2309 & E9-2310	E9-2346
 Sill 2-1/4" x 6"	E9-2303	 Glass Stop For 1" Glazing	E9-2341
 Jamb 2-1/4" x 6"	E9-2304	 Glass Stop For 1" Glazing	E9-2342
 Two Piece Mullion 2-1/4" x 6" Use with E9-2289	E9-2305	 Interior Trim Cover For 1" Glazing Use with E9-2341	E9-2343
 Two Piece Mullion Heavy Duty 2-1/4" x 6" Use with E9-2289	E9-2307	 Expansion Mullion (Female) Use with E9-2271 Weathering Gasket E2-0065 Not Included	E9-2270
 Two Piece SSG Mullion 2-1/4" x 6" Use with E9-2289	E9-2309	 Expansion Mullion (Male) Use with E9-2270	E9-2271
 Mullion Snap-In Filler Use with E9-2305, E9-2307 & E9-2309	E9-2289	 SSG Expansion Mullion (Female) Use with E9-2315 Weathering Gasket E2-0065 Not Included	E9-2316
 Tubular Mullion 2-1/4" x 6"	E9-2306	 SSG Expansion Mullion (Male) Use with E9-2316	E9-2315
 Tubular Mullion Heavy Duty 2-1/4" x 6"	E9-2308	 Sill Flashing (Economy) Not Thermally Broken	E9-2322
 Tubular SSG Mullion 2-1/4" x 6"	E9-2310	 Sill Flashing MegaTherm® Thermally Broken	BE9-2320

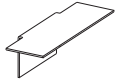
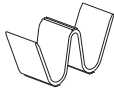

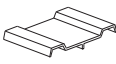

FRAMING MEMBERS

	Face Cover 2-1/4" x 1/2"	E9-2286		90° Outside Corner Face Cover Use with E9-2312 & E9-2313	E9-2349
	Face Cover 2-1/4" x 1"	E9-2284		Corner Post Filler Use with E9-2350, E9-2352 & E9-2354	E9-2314
	Face Cover 2-1/4" x 2"	E9-2268		90° Inside Corner Post Use with (2) E9-2314 & E9-2351	E9-2350
	Face Cover Extension	E9-2285		90° Inside Corner Trim Use with E9-2350 & E9-2314	E9-2351
	Reglaze Adaptor Use with E9-2301 & E9-2302	E9-2264		135° Outside Corner Post Use with (2) E9-2314 & (2) E9-2353	E9-2352
	Glazing Pocket Filler	E9-2345		135° Outside Corner Face Cover Use with E9-2352 & E9-2314	E9-2353
	90° Outside SSG Corner Mullion	E9-2311		135° Inside Corner Post Use with (2) E9-2314 & E9-2355	E9-2354
	90° Outside Corner Trim Base For 1" Glazing	E9-2550		135° Inside Corner Face Cover Use with E9-2354 & E9-2314	E9-2355
	90° Outside Corner Trim Cover For 1" Glazing	E9-3439		Transom Bar Sub-Frame	AS-0402
	90° Outside SSG Corner 1/4" Glazing Adaptor Use with E9-2311	E9-2347		Door Jamb Sub-Frame	E9-2344
	90° Outside Corner Post Use with E9-2313	E9-2312		Snap-In Door Stop Elastomer Weathering E2-0051 Included	AS-0417
	90° Outside Corner Post Use with E9-2312	E9-2313			

ACCESSORIES

	<p>Shear Block For Standard Horizontal Use with (2) PC-1228 & (2) PC-1208 Not Included</p>	<p>E1-1076</p>		<p>Head Anchor For Continuous Head & Sill Applications Only</p>	<p>E1-1097</p>
	<p>Shear Clip For Drop-Down Horizontal Use with (4) PC-1208 Not Included</p>	<p>E1-1077</p>		<p>Sill Anchor For Continuous Head & Sill Applications Only</p>	<p>E1-1098</p>
	<p>Shear Clip (Right Hand) For 90° SSG Corner Mullion Use with (4) PC-1208 Not Included</p>	<p>E1-1078</p>		<p>Setting Block Chair For Sill Use with E2-0178</p>	<p>E1-1080</p>
	<p>Shear Clip (Left Hand) For 90° SSG Corner Mullion Use with (4) PC-1208 Not Included</p>	<p>E1-1079</p>		<p>Setting Block For 1/4" Glazing</p>	<p>E2-0192</p>
	<p>Silicone Sill Flashing Splice Sleeve</p>	<p>E2-0070</p>		<p>Setting Block For 1" Glazing</p>	<p>E2-0178</p>
	<p>Sill Flashing End Dam</p>	<p>E1-9832</p>		<p>Side Block For Intermediate Mullion Shallow Glazing Pocket</p>	<p>E2-0134</p>
	<p>Mullion End Cap</p>	<p>E1-1093</p>		<p>Anti-Walk Block For Intermediate Mullion & Corner Mullion Deep Glazing Pocket</p>	<p>E2-0519</p>
	<p>Horizontal Bridge For Horizontals at SSG Verticals</p>	<p>E1-1090</p>		<p>Anti-Walk Block For Jamb Glazing Pocket</p>	<p>E2-0520</p>
	<p>Horizontal Bridge (Right Hand) For Horizontals at 90° SSG Corner</p>	<p>E1-1095</p>		<p>Water Deflector</p>	<p>E2-0047</p>
	<p>Horizontal Bridge (Left Hand) For Horizontals at 90° SSG Corner</p>	<p>E1-1096</p>		<p>End Dam For Head, Continuous Head & Sill Applications</p>	<p>E2-0522</p>
	<p>Face Cover Splice Sleeve For E9-2285 & E9-2286</p>	<p>E3-0039</p>		<p>End Dam For Sill, Continuous Head & Sill Applications</p>	<p>E2-0523</p>

ACCESSORIES

 <p>Weep Baffle For Sill at Weep Holes, Continuous Head & Sill Applications Only</p>	<p>E2-0099</p>	 <p>Weathering Gasket Use with E9-2270 Expansion Mullion</p>	<p>E2-0065</p>
 <p>Thermal Isolator Clip For Attachment of Perimeter Face Covers</p>	<p>E3-0037</p>	 <p>#10 x 3/8" PHMS Type AB, Zinc Plated Steel For Attachment of Mullion End Cap</p>	<p>PC-1006</p>
 <p>Temporary Glass Retainer For 1" Structural Silicone Glazing</p>	<p>E3-0001</p>	 <p>#10-24 x 3/8" PHMS Stainless Steel For Attachment of Sill to Sill Flashing</p>	<p>PM-1006 -SS</p>
 <p>Temporary Glass Retainer For 1/4" Structural Silicone Glazing</p>	<p>E3-0006</p>	 <p>#10 x 1/2" PHMS Type AB, Zinc Plated Steel For Attachment of E9-2314 to Corner Posts</p>	<p>PC-1008</p>
 <p>Temporary Glass Retainer For 90° Outside SSG Corner</p>	<p>E1-3588</p>	 <p>#12 x 1/2" FHSMS Type AB. Zinc Plated Steel For Attachment of Horizontal to E1-1076 at Door Jamb</p>	<p>FC-1208</p>
 <p>Exterior Glazing Gasket</p>	<p>E2-0511</p>	 <p>#12 x 1/2" PHMS Type AB, Zinc Plated Steel For Attachment of Shear Clip E1-1077 to Mullions</p>	<p>PC-1208</p>
 <p>Interior Glazing Gasket</p>	<p>E2-0171</p>	 <p>#1/4"-20 x 1" HWHMS Zinc Plated Steel For Attachment Corner Temp Glass Retainer</p>	<p>HM-2516</p>
 <p>Exterior Glazing Gasket Silicone Compatible For Frames with SSG Verticals</p>	<p>E2-0516</p>	 <p>#12 x 1-1/4" PHMS Type AB, Zinc Plated Steel For Screw Spline Attachment</p>	<p>PC-1220</p>
 <p>Interior Glazing Gasket Silicone Compatible For Frames with SSG Verticals</p>	<p>E2-0524</p>	 <p>#12 x 1-3/4" PHMS Type AB, Zinc Plated Steel For Attachment of Shear Block E1-1076 to Vertical</p>	<p>PC-1228</p>
 <p>SSG Glazing Spacer For Outside Glazing of SSG Verticals</p>	<p>E2-0176</p>	 <p>#12 x 3/4" UFHSMS Type A, Zinc Plated Steel For End Dam Attachment</p>	<p>UA-1212</p>
 <p>SSG Glazing Spacer For Inside Glazing of SSG Verticals</p>	<p>E2-0521</p>		

FRAME FABRICATION

**STEP 1
DETERMINE FRAME SIZE**

Determine Frame Width:

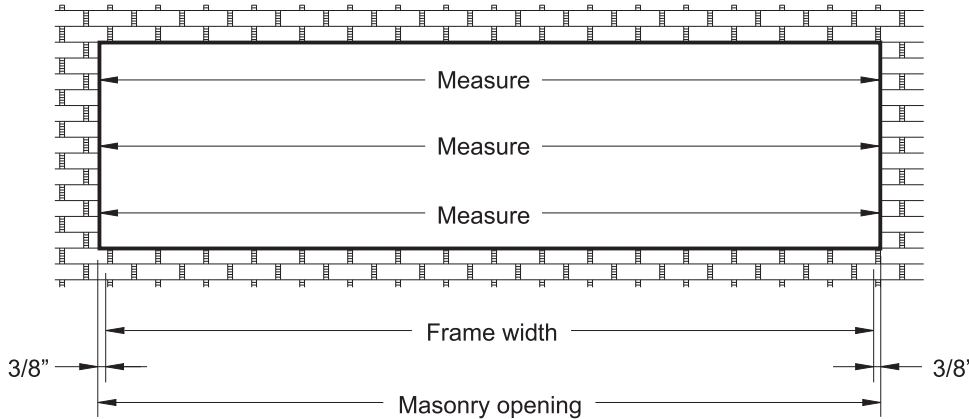

Note: Check the opening for squareness and plumb at both ends. Units must be installed in a true rectangle.

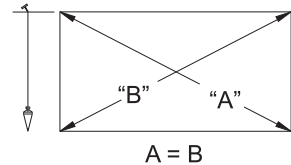

DETAIL 1

- Measure the width of the masonry opening at the top, middle, and bottom.
 - Select the smallest dimension measured and subtract 3/4" to determine the frame width.
- See **Detail 1**.

Determine Frame Height:

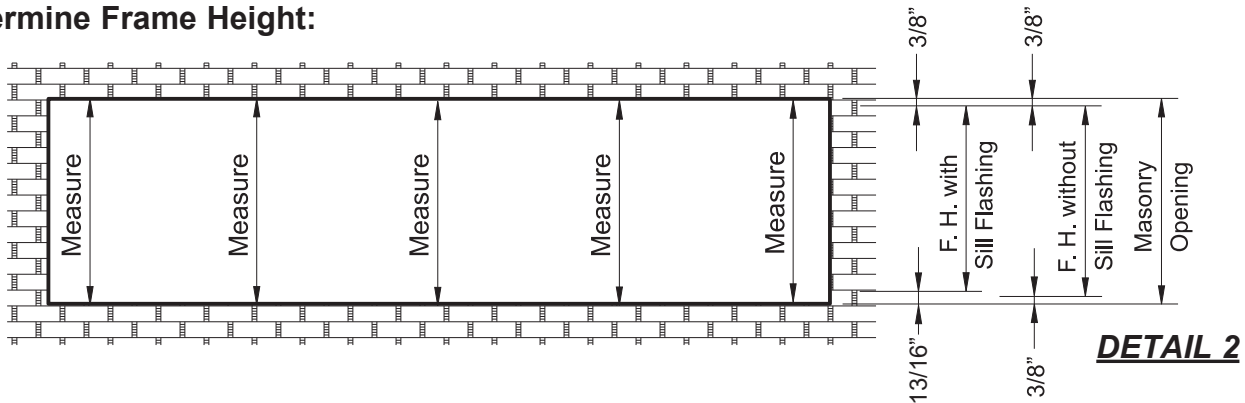

DETAIL 2

- Measure the height of the masonry opening several times along the entire length of opening and select the smallest dimension for the masonry opening height. See **Detail 2**.

To calculate frame height:

For Mullion Through Frames:

- Subtract 1-3/16" from the masonry opening height:
 - 3/8" caulk joint at head.
 - 7/16" sill flashing.
 - 3/8" caulk joint below flashing.

For Continuous Head & Sill Frames:

- Subtract 3/4" from the masonry opening height:
 - 3/8" caulk joint at head.
 - 3/8" caulk joint below sill member

NOTE: Vertical through frame widths over 24'-0" require expansion mullions every 12 to 15 feet (best location at vertical next to door jamb.)
 YWE 60 T must be installed with sill flashing, E9-2322 or BE9-2320, for vertical through applications. Sill flashing is not required when head and sill members run continuous (frames 24'-0" or smaller).

FRAME FABRICATION

STEP 2 FABRICATE SILL FLASHING (Mullion Through Frames Only)

- Cut the sill flashing, BE9-2320 or E9-2322, to the frame width determined in **Step 1**: Masonry opening width minus(-) 1/4" (1/8" at each jamb).
 - Allow for a 3/8" splice joint between sill flashing members on longer runs.
 - Mark the quarter points between mullions on the sill flashing.
 - Drill a 5/16" diameter weep hole in the face of the sill flashing at each quarter point.
- See **Detail 3**.

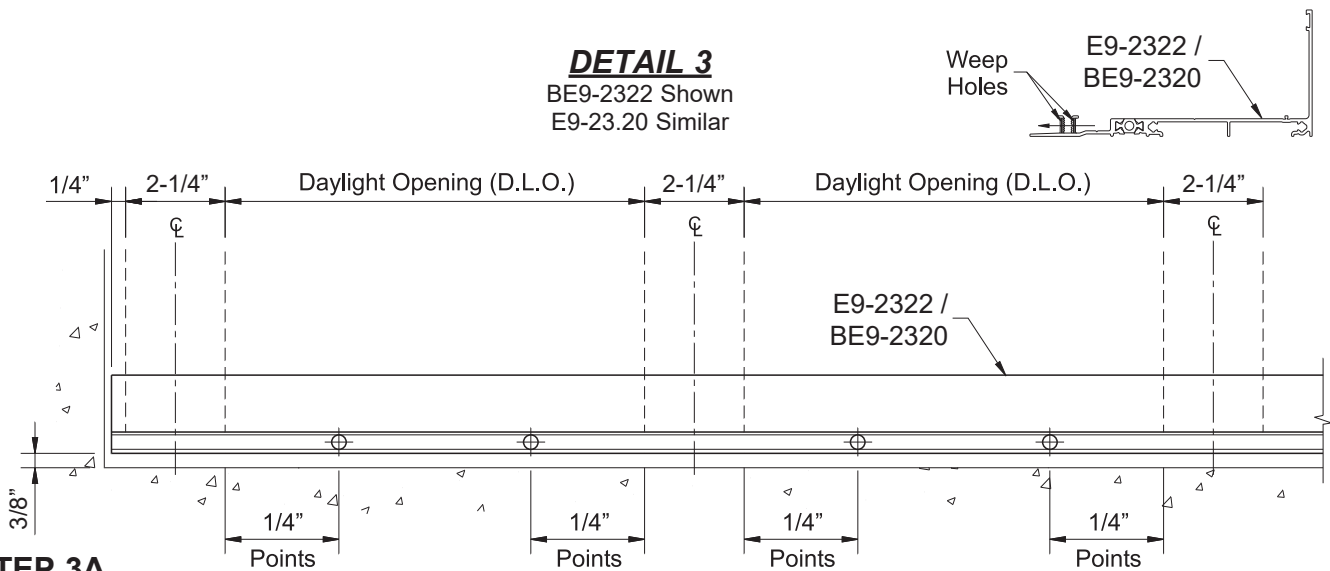

STEP 3A FABRICATE HEAD & SILL MEMBERS FOR MULLION THROUGH FRAMES

- Cut head and sill members to the daylight opening dimension between verticals.
 - Fabricate sill members for anchoring to sill flashing:
 - Measure in 6" from each end of the sill member and mark hole locations along the glazing pocket "V"-groove.
 - Mark additional hole locations a maximum of 24" on center (O.C.).
 - Drill a 0.213" diameter (#3 drill bit) hole at each location marked.
- See **Detail 4**.

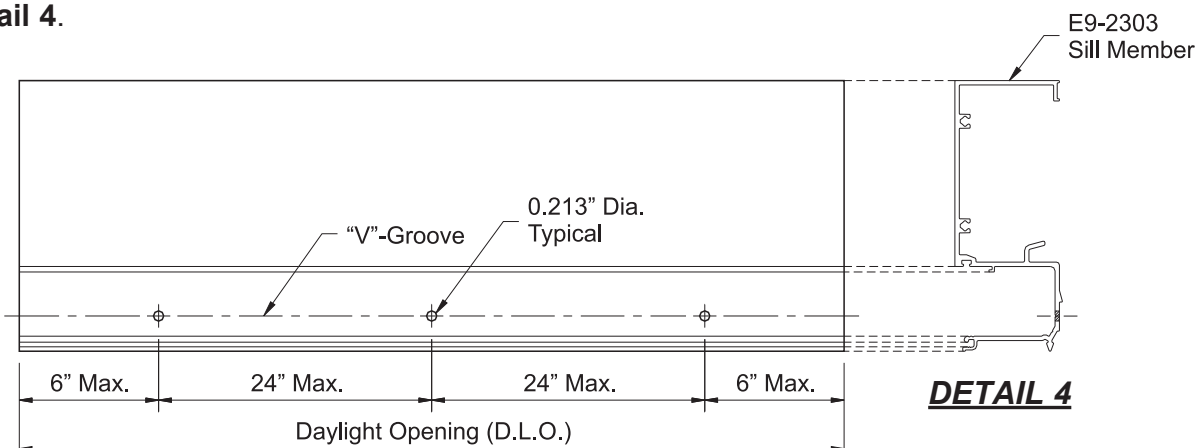

FRAME FABRICATION

STEP 3B

FABRICATE HEAD & SILL FOR CONTINUOUS HEAD & SILL FRAMES

-Cut head and sill members to the frame width determined in **Step 1**.
 -Mark hole locations on the head and sill members for screw spline attachment of mullions using one of the methods below:

-Using short pieces of mullions as a template, line up the glazing pockets and mark hole locations through the screw splines.

OR

-Layout hole locations on head and sill as shown in **Detail 5**.

-Drill 0.236" diameter (#B drill bit) clearance holes at each location marked.

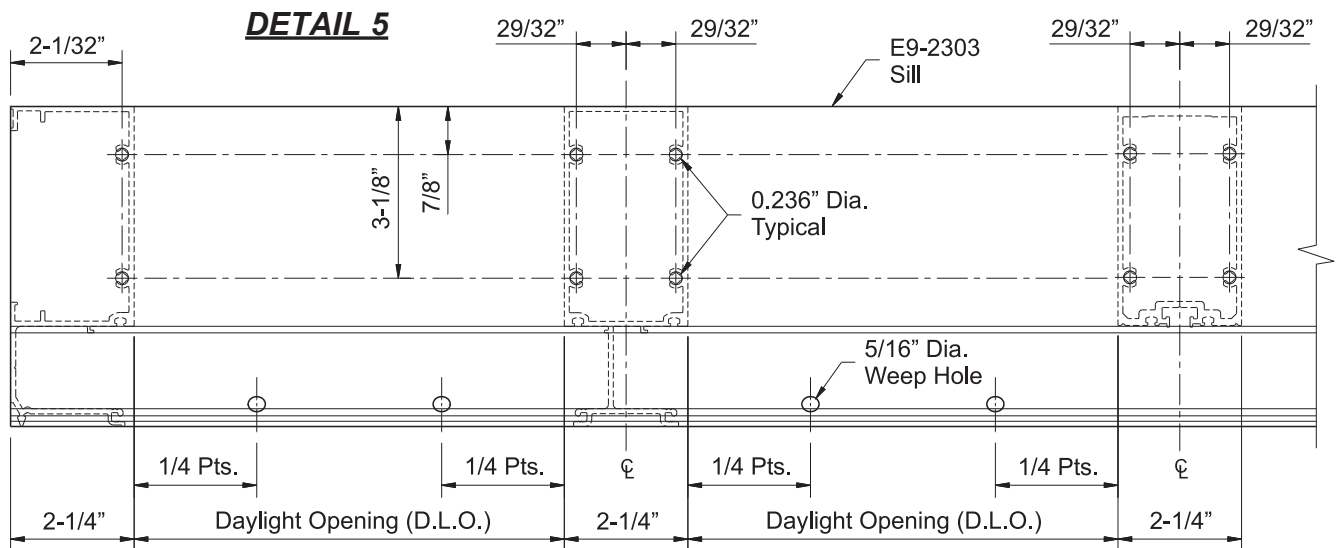

Continuous head and sill frames require weep holes at the sill:

-Mark the sill members, E9-2303, at 1/4 points of daylight opening between mullions along the "V"-Groove on the underside of the sill member as shown.

-Drill 5/16" diameter weep holes at each location marked.

See **Details 5 & 6**.

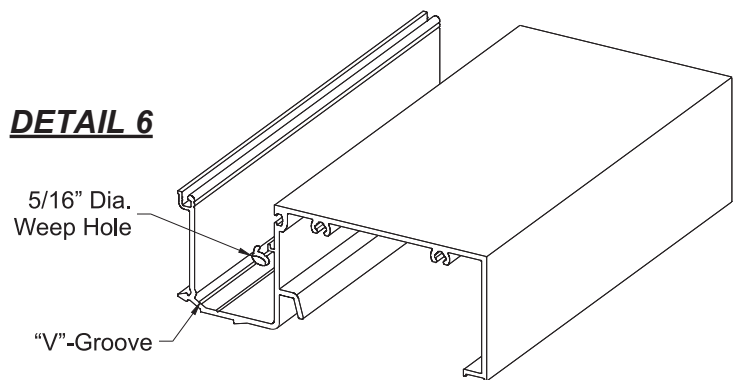
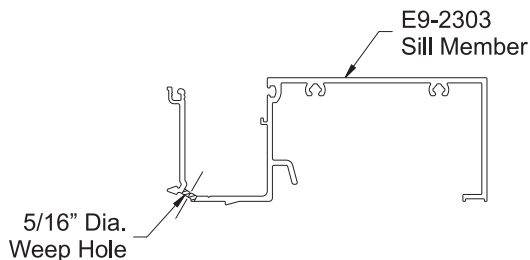

FRAME FABRICATION

STEP 4 FABRICATE INTERMEDIATE HORIZONTALS

-Cut intermediate horizontals to the daylight opening between mullions.

Horizontals that will be attached to tubular mullions require additional fabrication for the shear block or clip:

- Measure in 1" from each end of the horizontal and mark the location on each of the "V"-Grooves on the bottom side of the horizontal.
- For shear block **E1-1076** drill a **0.236" (#B)** diameter hole at each location marked.
- For shear clip **E1-1077** drill a **0.189" (#12)** diameter hole at each location marked.

Note: E1-1077 is required for the end bay when using stick built construction.

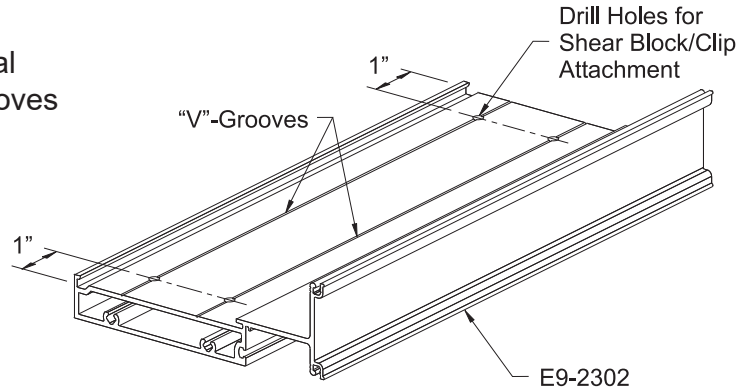

DETAIL 7

See **Detail 7**.

STEP 5 FABRICATE TWO PIECE MULLIONS FOR MULLION THROUGH FRAMES

-Cut all jamb and two piece mullions to the frame height determined in **Step 1**.

Fabricate holes in the mullions for screw spline attachment using one of the methods below:

- Using short pieces of horizontals as a template, line up the glazing pockets and mark hole locations through the screw splines of the templates.

OR

- Layout hole locations on mullions as shown in **Detail 8**.

-Drill 0.236" diameter (#B drill bit) holes at each location marked.

See **Detail 8**.

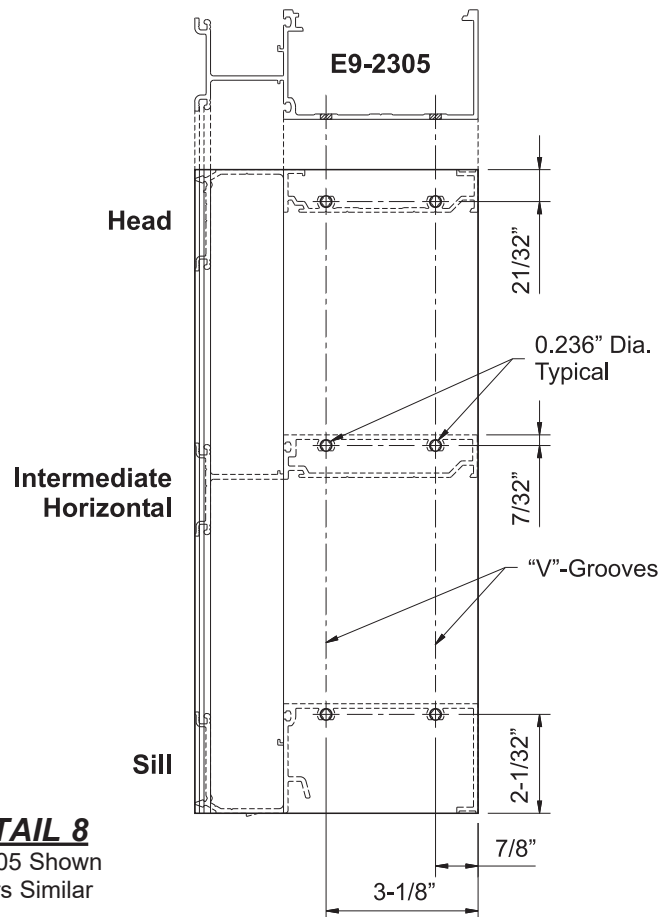

DETAIL 8
E9-2305 Shown
Others Similar

FRAME FABRICATION

STEP 5A

FABRICATE VERTICALS FOR CONTINUOUS HEAD & SILL FRAMES

-Cut the intermediate and jamb mullions to the frame height determined in **Step1** minus(-) 3-1/8”.

When using continuous head and sill frames, the intermediate and jamb mullions must be notched to fit up into the head member.

- Measure down 1-3/8” from the top of the mullion and draw a line across the face of the mullion.
- Notch the mullions down to this line and 3/8” back.

Fabricate verticals for intermediate horizontal attachment by shear block or clip:

- Draw a line across the side of the mullion where the top of the intermediate horizontal will be.
- Draw a second line below the first one: 9/16” for E1-1076 or 1-9/16” for E1-1077
- Mark hole locations along this line at 7/8” and 3-1/8” from the back of the mullion.
- Drill 0.189” diameter (#12 drill bit) holes at each location marked.
- Attach shear blocks, E1-1076, with two PC-1228 fasteners.
- Attach shear clips, E1-1077, with two PC-1208 fasteners.

See **Details 9 & 10**.

STEP 5B

EXPANSION MULLIONS

- An Expansion Mullion is to be used every fifteen to twenty feet in large openings.
- The dimension of the assembly should be adjusted based on the temperature at the time of assembly and expected high and low service temperatures, use 2-1/4” as a reference dimension. For example, the sightline will be reduced slightly when installed in hot weather and increased slightly if installed in cold weather.

Note: Horizontals may also be attached by screw spline attachment at jambs.

STANDARD EXPANSION MULLION

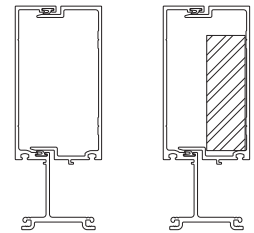

SSG EXPANSION MULLION

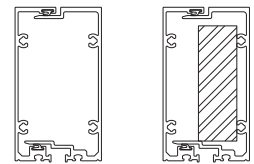

DETAIL 10

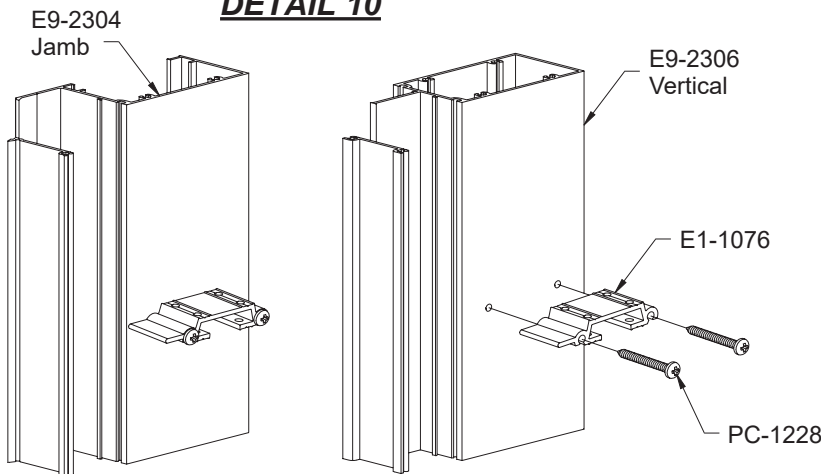

DETAIL 9

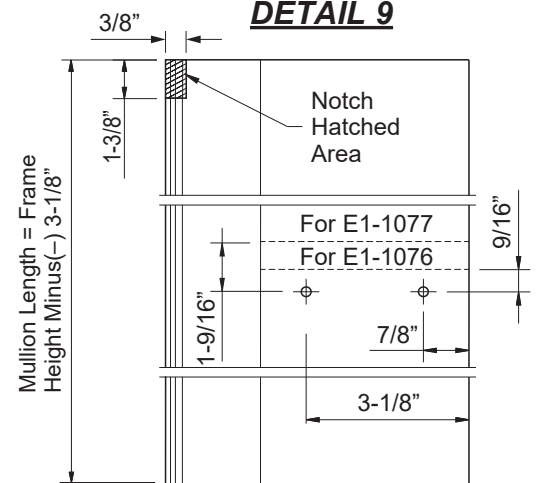

FRAME FABRICATION

**STEP 6
FABRICATE GLASS STOPS & INTERIOR TRIM COVERS**

- Cut glass stops, E9-2341 for 1" glazing and E9-2342 for 1/4" glazing:
Cut Length = Daylight Opening minus(-) 1/32".

When using shear clips, E1-1077, the glass stops must be notched to clear the shear clips.
-Notch the back leg of the glass stop at each end: 1-1/2" from the ends and 1/2" back.

See **Detail 11**.

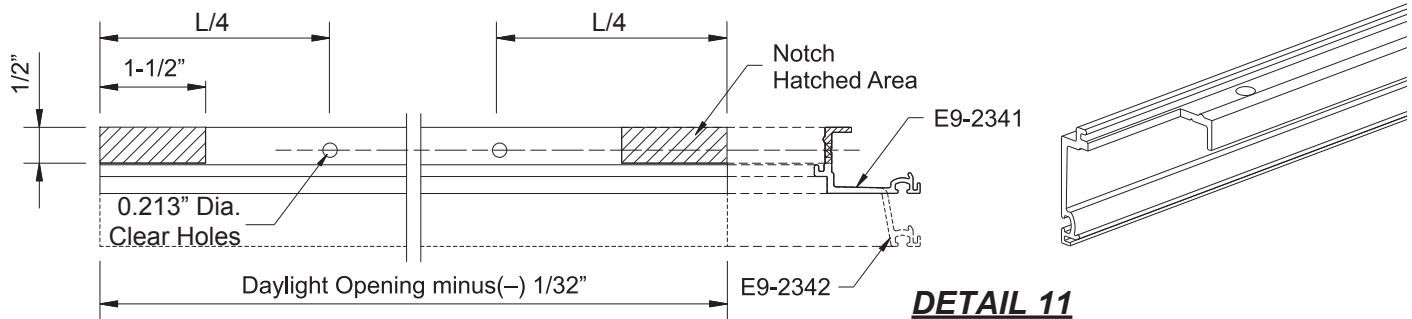

- Interior trim covers, E9-2343, are used at head and intermediate horizontals for vision areas only.
-Cut interior trim covers: Cut Length = Daylight Opening minus(-) 1/32".
-Drill (2) 0.213" dia clear holes at 1/4 points as shown.

**STEP 7
FABRICATE FACE COVERS**

For Mullion Through Frames:

- Cut vertical face covers to the same dimension as their respective mullions.
- Cut horizontal face covers to the daylight opening between mullions minus(-) 1/32".

For Continuous Head & Sill Frames:

- Cut vertical face covers to the daylight opening height minus(-) 1/32".
- Cut head and sill face covers to the frame width determined in **Step 1**.
- Cut intermediate horizontal face covers to the daylight opening between mullions minus(-) 1/32" for captured mullions.

Note: If using SSG mullions, horizontal face covers may run continuous across SSG verticals. An expansion joint, 1/2" wide, is required every 12 to 15 feet; this joint should occur at the centerline of a SSG mullion. See approved shop drawings for all horizontal face cover dimensions if using SSG mullions.

FRAME ASSEMBLY

**STEP 8
ATTACH MULLION END CAPS
(For Mullion Through Frames Only)**

- Mullion end caps are only required at the top end of jamb and mullions of vertical through frames.
- Clean the mullion end and mullion end cap with a cleaner and method approved by the sealant manufacturer.
- Apply sealant to the gasket reglet and along the front of the mullions prior to installing mullion end caps, E1-1093.
- Attach the mullion end caps to the mullions with (1) PC-1006 fastener.
- Tool the excess sealant along the inside of the glazing pocket between the mullion end cap and the mullion.
- Seal all screw heads.

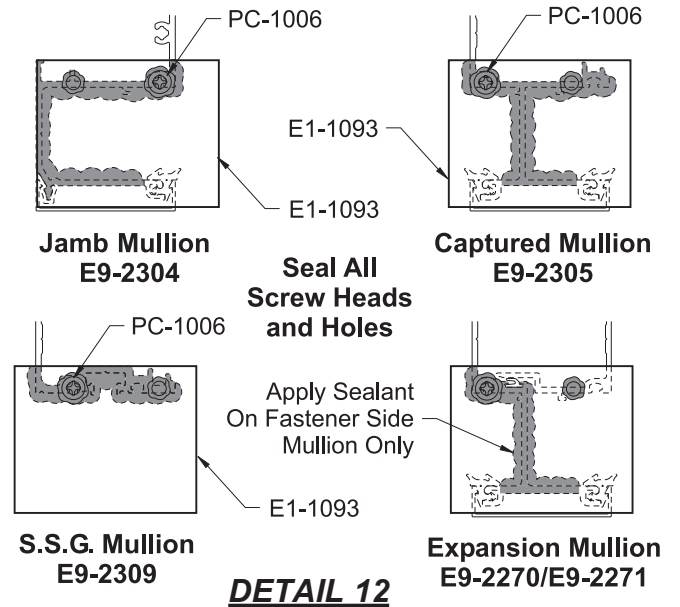

See **Detail 12**.

**STEP 9
INSTALL END DAMS
(For Continuous Head & Sill Frames Only)**

The ends of head and sill members of continuous head & sill frames must be plugged using end dams, E2-0522 at the head and E2-0523 at the sill.

Use the following technique to install end dams at the head and sill:

- Clean the ends of the head and sill members with a cleaner and method approved by sealant manufacturer.
- Apply sealant to all contact sides of the end dam.
- Insert the end dam into each end, leaving it 1/8" recessed from the edge of the mullion.
- Apply sealant to the end dams and tool the sealant flush with the ends of the mullion.

See **Detail 13**.

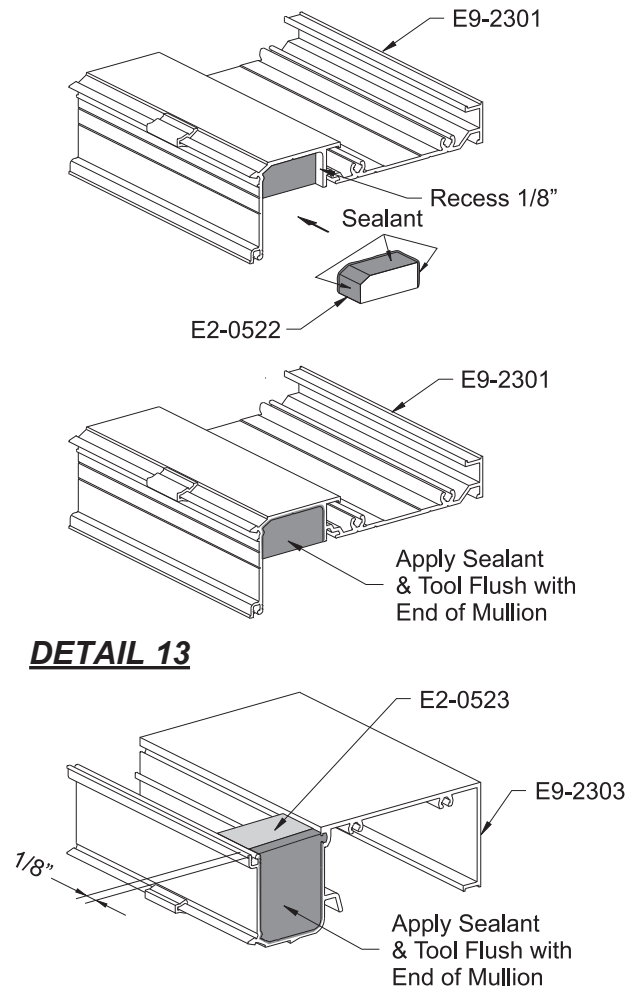

FRAME ASSEMBLY

STEP 10 ATTACH FACE COVERS

For Mullion Through Frames:

- Attach only the mullion and jamb covers at this time:
- Cut exterior glazing gaskets for vertical and jamb members to the mullion length plus(+) 3/16" per foot of mullion height.

For Continuous Head & Sill Frames:

- Attach only the head and sill covers at this time:
- Cut exterior glazing gaskets for continuous head and sill members to the mullion length plus(+) 3/16" per foot of mullion length.

Note: When SSG mullions are used, E2-0516 silicone compatible glazing gasket must be used instead of E2-0511 for the exterior. For the interior, use E2-0524 instead of E2-0171.

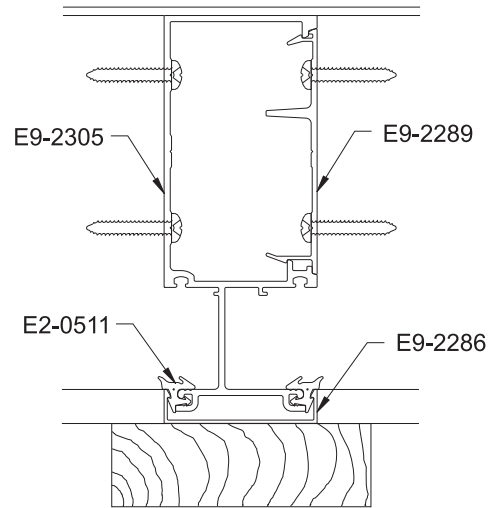

DETAIL 14

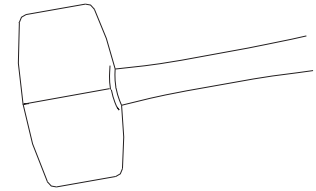

- Insert each end of the glazing gasket into the gasket reglet first and then insert the gasket at the midpoint of the mullion.
- Roll in the gasket working from the midpoint towards each end.

To Install Intermediate Face Covers:

- Using a rubber mallet and a clean piece of lumber, carefully snap on the face covers starting at one end and work towards the other end.
- See **Detail 14**.

To Install Perimeter Face Covers:

- Snap on thermal isolator clips, E3-0037, on perimeter members 3" from each end and no more than 12" on center.
- Set the face cover on the glazing gasket first and roll the cover towards the isolator clips to snap in place.
- See **Detail 15**.

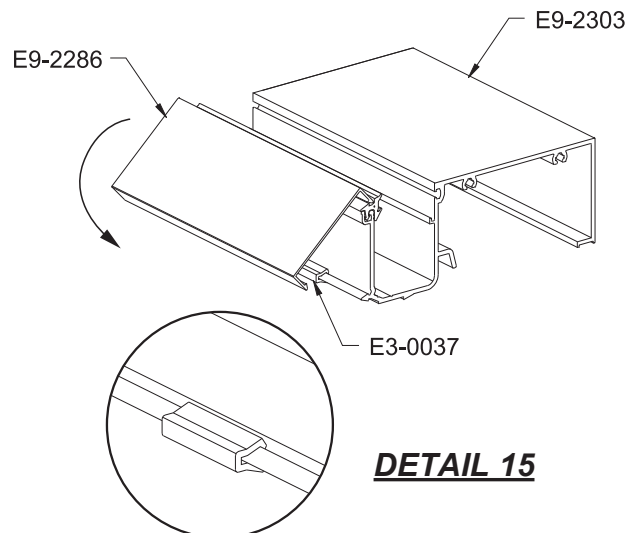

DETAIL 15

FRAME ASSEMBLY

STEP 11A ASSEMBLE FRAMES

Mullion Through Frames:

- Clean the ends of horizontals and attachment areas of mullions using a cleaner and method approved by sealant manufacturer.
- Apply (butter) sealant to both ends of head, horizontal, and sill just prior to assembly.
- Attach heads, horizontals, and sills to the two piece mullions with two (2) PC-1220 fasteners at each end.
- Using a clean cloth, wipe off the excess sealant while pushing it into the joints.

See **Detail 16**.

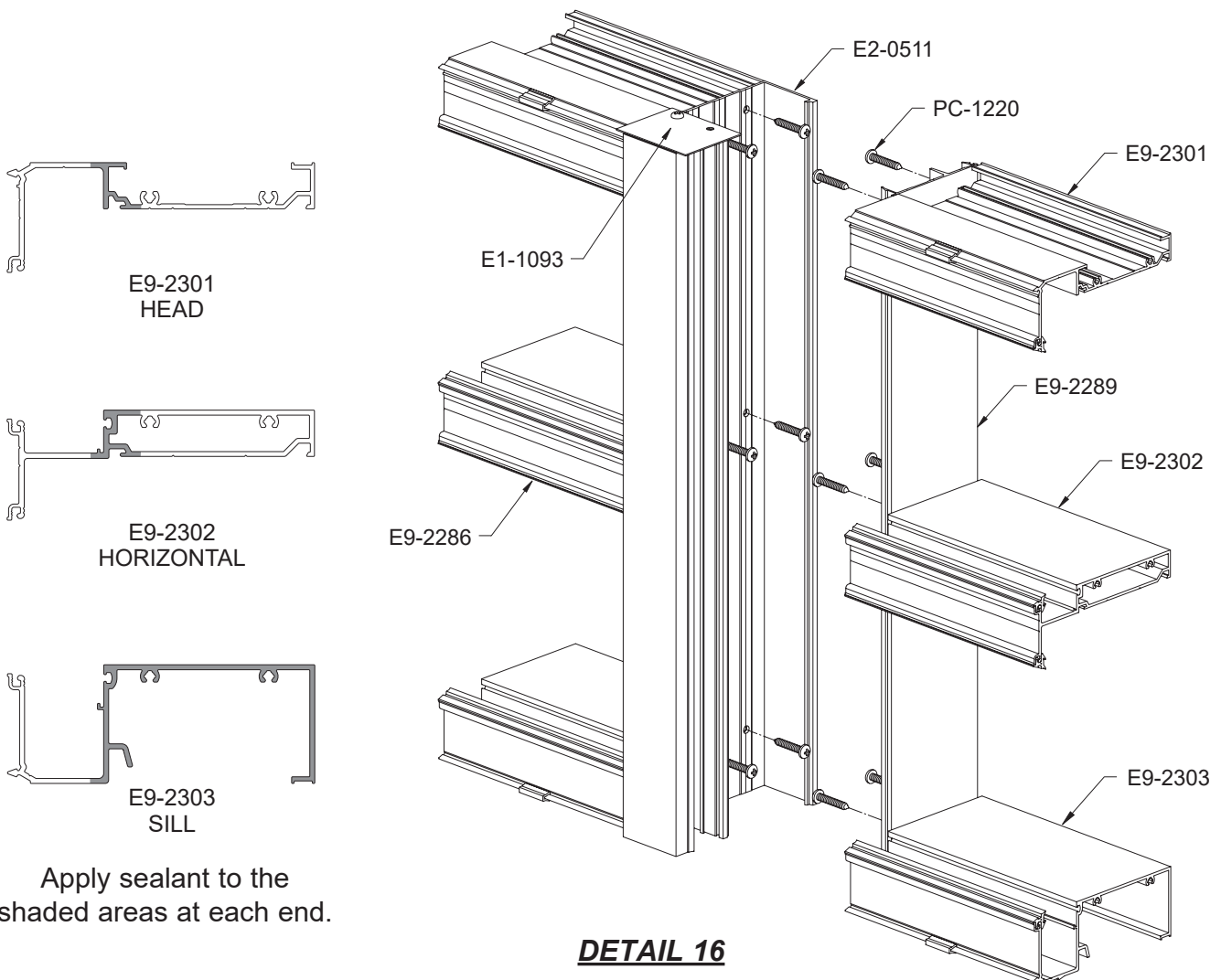

FRAME ASSEMBLY

STEP 11B ASSEMBLE FRAMES

Continuous Head & Sill Frames:

- Clean the ends of mullions and attachment areas of head and sill members using a cleaner and method approved by sealant manufacturer.
- Apply (butter) sealant to both ends of jamb and mullions just prior to assembly.
- Attach jambs and mullions to the head and sill members using (2) PC-1220 fasteners per jamb and (4) PC-1220 fasteners per intermediate mullion.
- Apply (butter) sealant to both ends of the intermediate horizontal members and to the front top portion of the shear block just prior to assembly.
- Attach intermediate horizontals to the shear blocks using (2) PC-1208 fasteners at each end.
- Using a clean cloth, wipe off the excess sealant while pushing it into the joints.

See **Detail 17**.

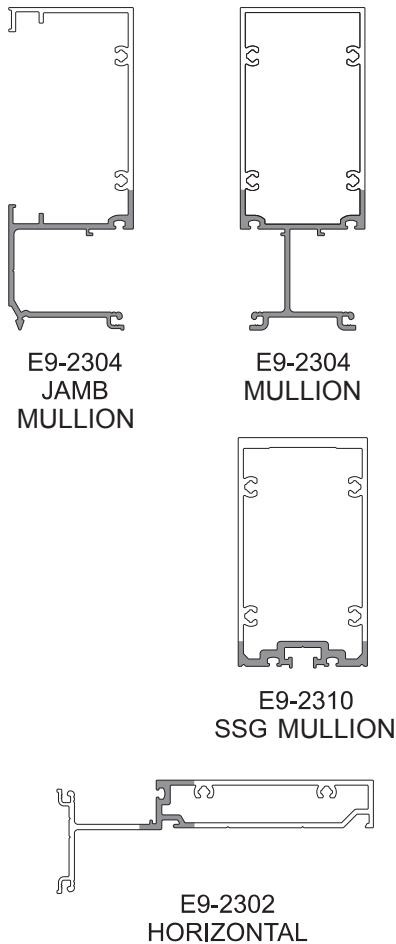

Apply sealant to the shaded areas at each end.

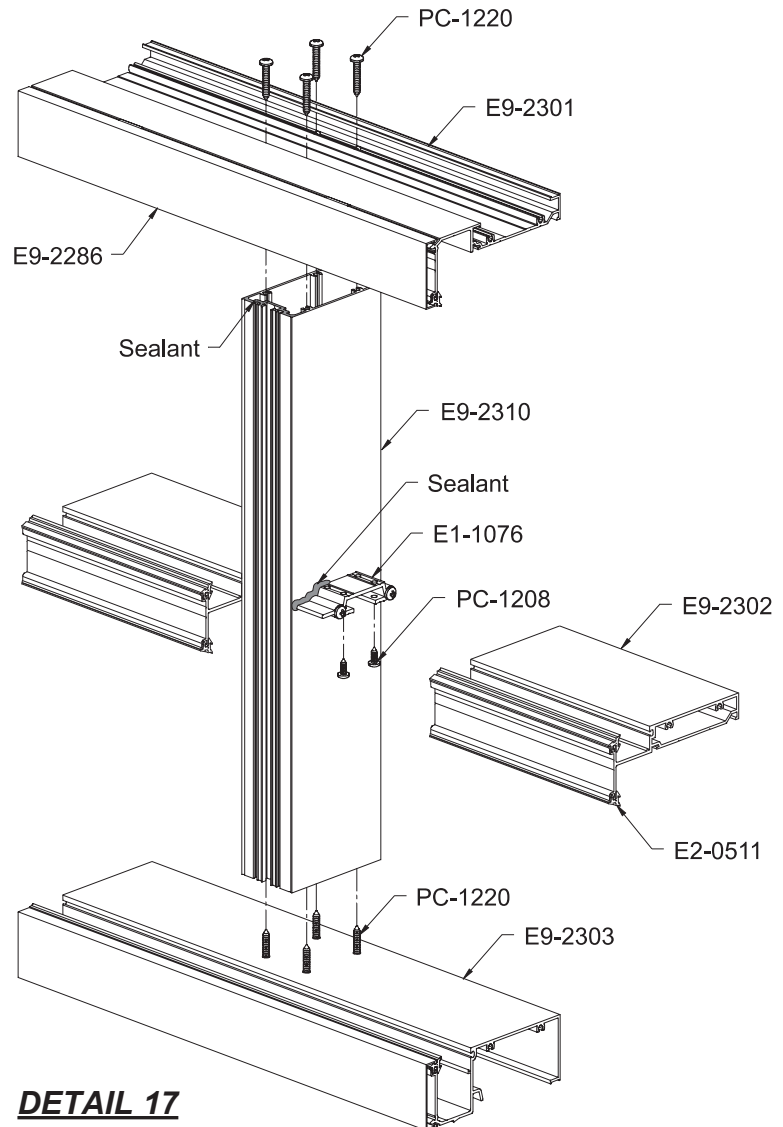

FRAME INSTALLATION

STEP 12

INSTALL SILL FLASHING END DAMS (For Vertical Through Frames Only)

- Clean all joint surfaces using cleaner approved by sealant manufacturer.
- Apply sealant to the end of the sill flashing as shown in **Detail 18**.
- Fasten the end dam to the sill flashing with two UA-1212 screws, starting at the back followed by the front as shown in **Detail 18**.
- Tool sealant along the joint between the end dam and the sill flashing as shown in **Detail 19**.
- Seal over any exposed screw threads.

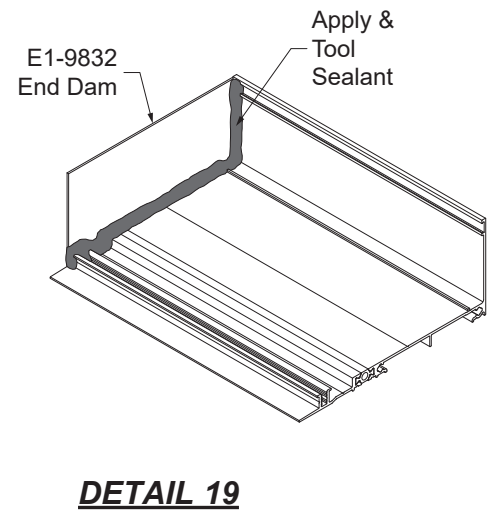
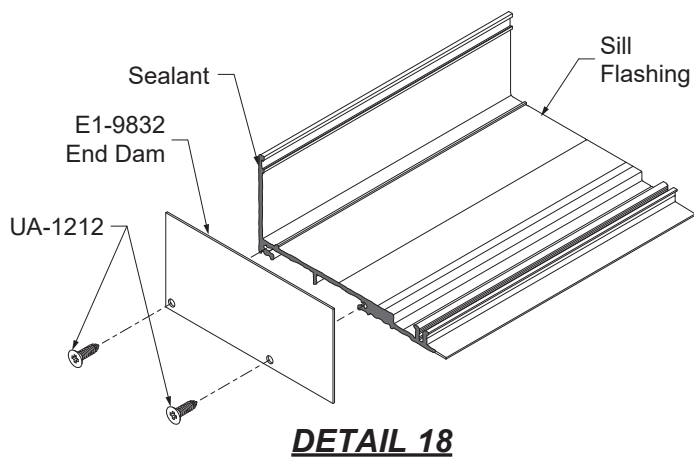

FRAME INSTALLATION

STEP 13 INSTALL SILL FLASHING

- Install the sill flashing with a minimum of 3/8" shim underneath. Sill flashing must be installed level.
- Anchor the sill flashing to the structure a maximum of 4" from each end and then 18" to 24" on center, or per P.E. calculations.
- Apply and tool sealant to cover the heads of all anchor fasteners.

- Remove the nub with a chisel or pliers on both sides of the splice joint 1-1/2" as shown in **Detail 21**.
- After the sill flashing has been shimmed and installed to the building structure, insert a small backer rod under the sill flashing as shown in **Detail 22**.
- Position the Silicone Splice Sleeve into the front of the channel as shown. Mark and cut the sleeve at this position.
- Clean Sill Flashing and Silicone Splice Sleeve with isopropyl alcohol at the splice location.
- Seal the flashing at the splice location as shown in **Detail 22**, before positioning the flashing. Set the Silicone Splice Sleeve into the sealant.
- Tool sealant tight as shown in **Detail 23**, squeezing the sheet flat with a seam roller.

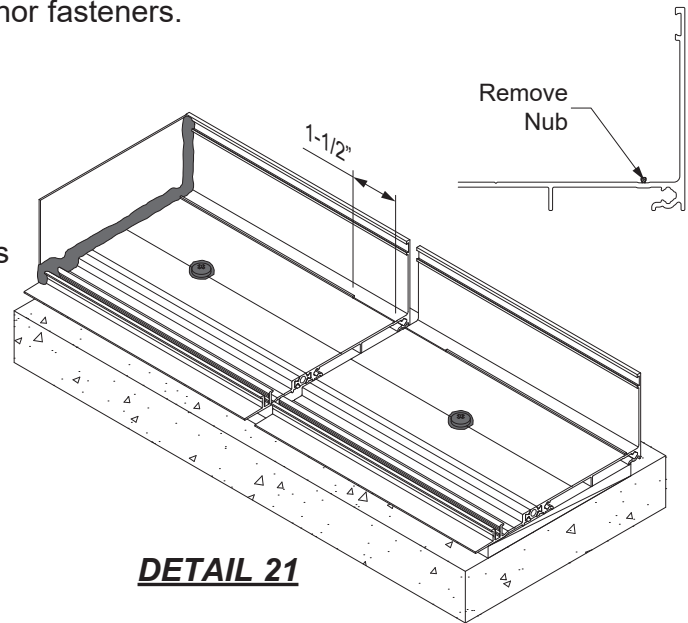

DETAIL 21

When using E2-0070, a compatible Silicone Sealant must be used at the splice.

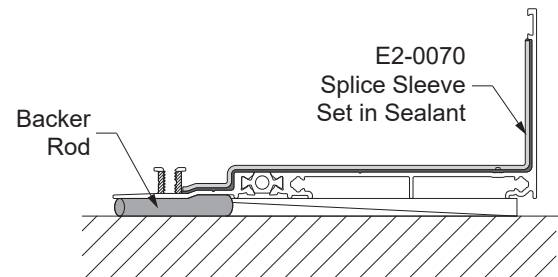
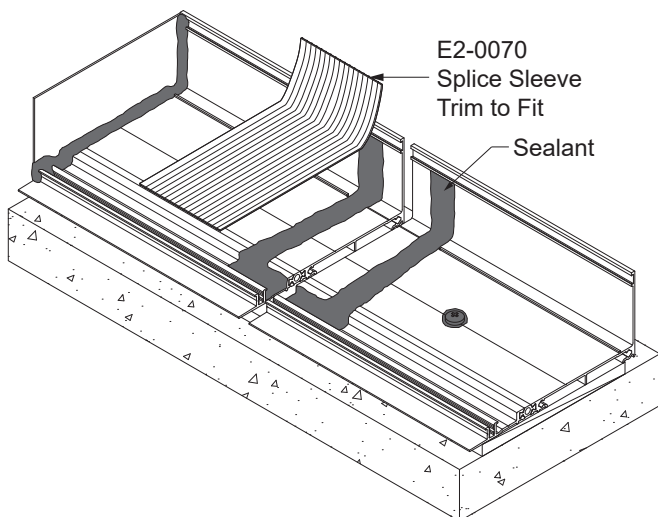

DETAIL 22

FRAME INSTALLATION

**STEP 13 (Continued)
INSTALL SILL FLASHING**

-Apply masking tape to the back of the sill flashing and at the front of the splice as shown in **Detail 23**.

-Thoroughly seal the small joint directly in front of the Silicone Splice Sleeve. Carefully remove masking tape from the front gap before the sealant skins over.

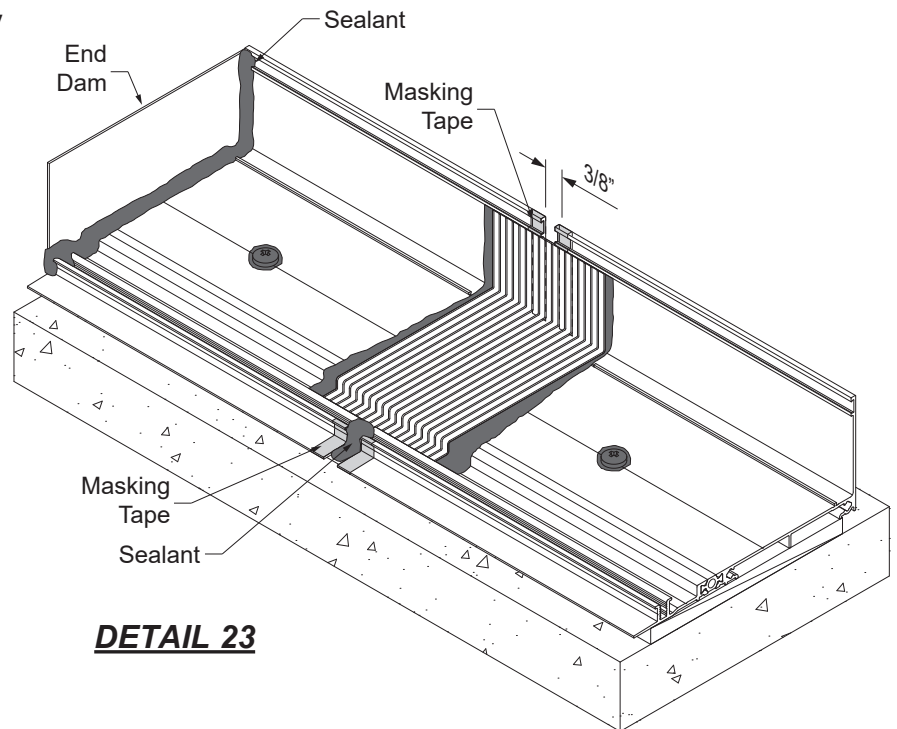

DETAIL 23

**STEP 14
SILL PREPARATION**

-At every splice condition, apply bond breaker tape to the back of the sill member before the joint is sealed between the sill and sill flashing.

See **Detail 24**.

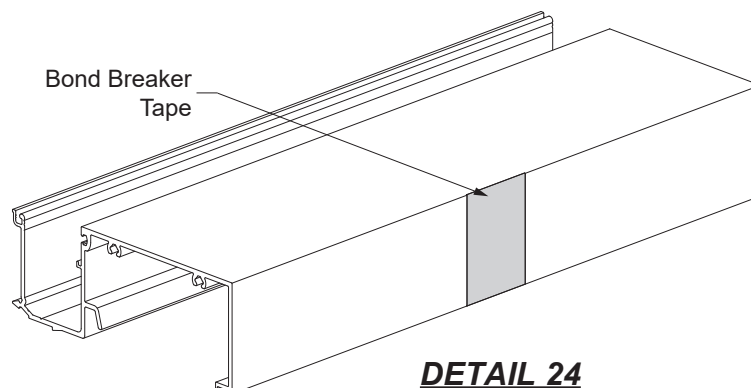

DETAIL 24

FRAME INSTALLATION

**STEP 15
INSTALL SILL FLASHING AT CORNERS**

- Cut two 12" long pieces of sill flashing E9-2322 / BE9-2320 and miter (45° for 90° corners and 67.5° for 135° corners).
- Align the two pieces at the corner condition with the mitered ends pushed together tight and anchor the sill flashing as called out on shop drawings.
- Apply and tool sealant to the mitered joint and anchor heads.

See **Detail 25**.

- Continue installing the rest of the sill flashing providing a 3/8" joint at splices as shown in **Step 13** on **Page 16**.

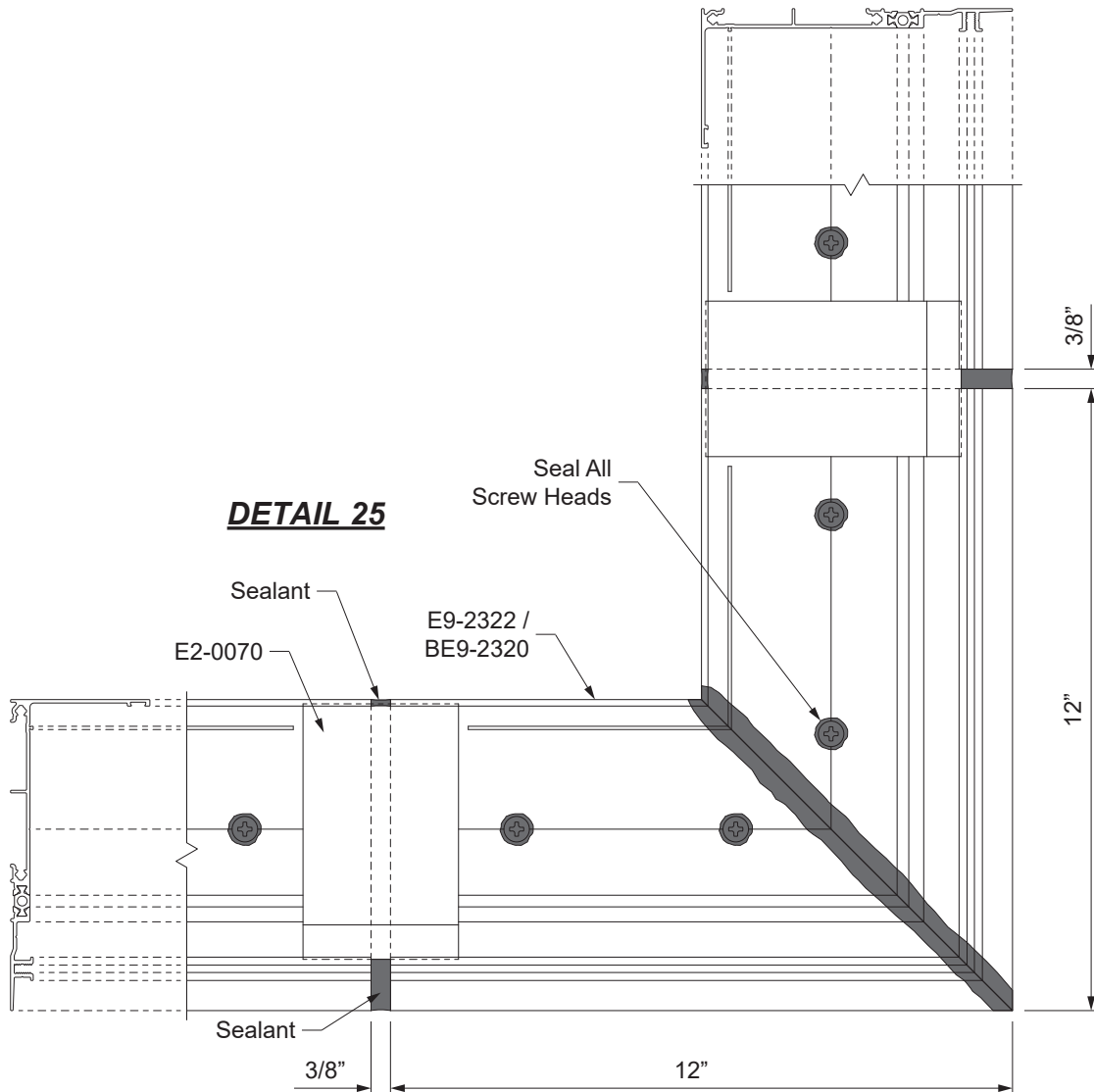

FRAME INSTALLATION

STEP 16
INSTALL MULLION THROUGH FRAMES

- Immediately before installing the frames, apply a continuous bead of sealant to the back leg of the sill flashing. Make sure all surfaces are clean.
- Snap frame assemblies together and set onto the sill flashing.
- Shim the head and jamb mullions to ensure that the frame is installed plumb, square, and true.
- Anchor the head members at 6" on each side of every vertical centerline and then no more than 24" on center.
- Anchor jamb members 6" from each end and then no more than 24" on center.

Note: Shims must be installed at all anchor points.

- Sill members, E9-2303, must be attached to the sill flashing with a PM-1006-SS fastener at each hole previously drilled during sill fabrication.
- Seal all anchor heads.

See **Detail 26**.

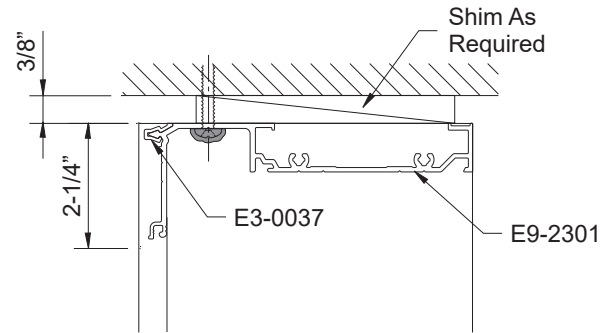

DETAIL 26

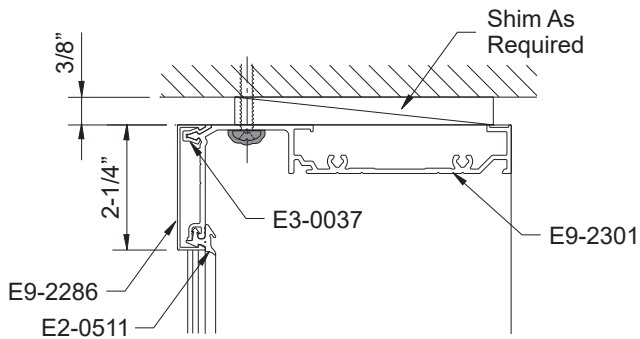
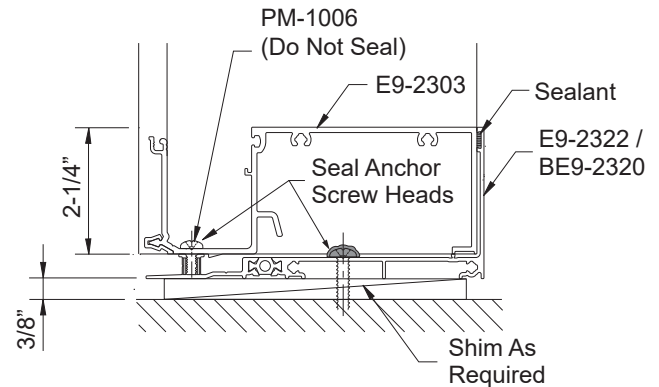

DETAIL 27

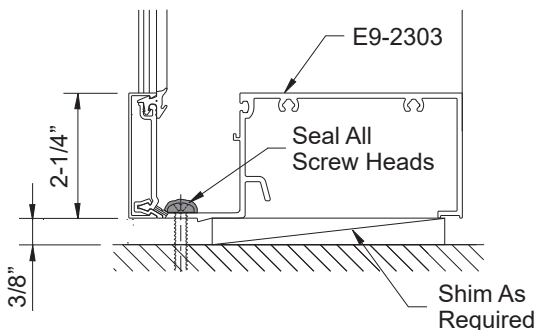

INSTALL CONTINUOUS HEAD & SILL FRAMES

- Strike a line along the structure at the sill condition that will be the exterior face of the frame.
- Set the assembled frame into the opening and align it with the line representing the exterior face.
- Start installing the frame at the smallest opening height with a 3/8" minimum shim at the sill.
- Shim the frame as required to ensure that it is installed level, square, and true.
- Anchor the head and sill members at 6" on each side of every mullion centerline and then no more than 24" on center.
- Anchor jamb members 6" from each end and then no more than 24" on center.

Note: Shims must be installed at all anchor points.

- Seal all anchor heads.

See **Detail 27**.

FRAME INSTALLATION

STEP 17 INSTALL CONTINUOUS HEAD & SILL FRAMES USING OPTIONAL HEAD & SILL ANCHORS

Locate Sill Anchor Placement

- At the sill condition, locate and mark each vertical mullion center line.
- Determine the inset to the external face of the system in relation to the surrounding condition. Consult shop drawings for this dimension.
- Add 3-3/8" to the inset dimension and mark at each end of the opening. Complete by snapping a chalk line from both locations.

Install Optional Sill Anchor, E1-1098

- Jamb anchors are to be located flush to the ends of the system. The E1-1098 Sill Anchor is 6" long.
- Intermediate mullion anchors will center over the previously marked mullion center lines.
- Match drill the structure for each sill anchor.

Note: Anchor fastener size, location, and quantity may vary as required by engineering calculations.

- Install sill anchors with 1/4" minimum shim underneath to ensure that the system will be installed level.

See **Detail 28 & 29**.

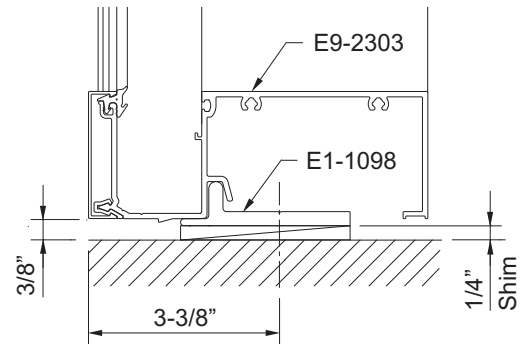
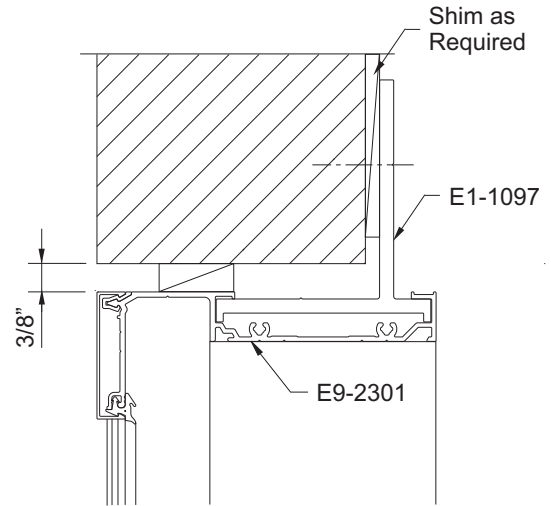

DETAIL 28

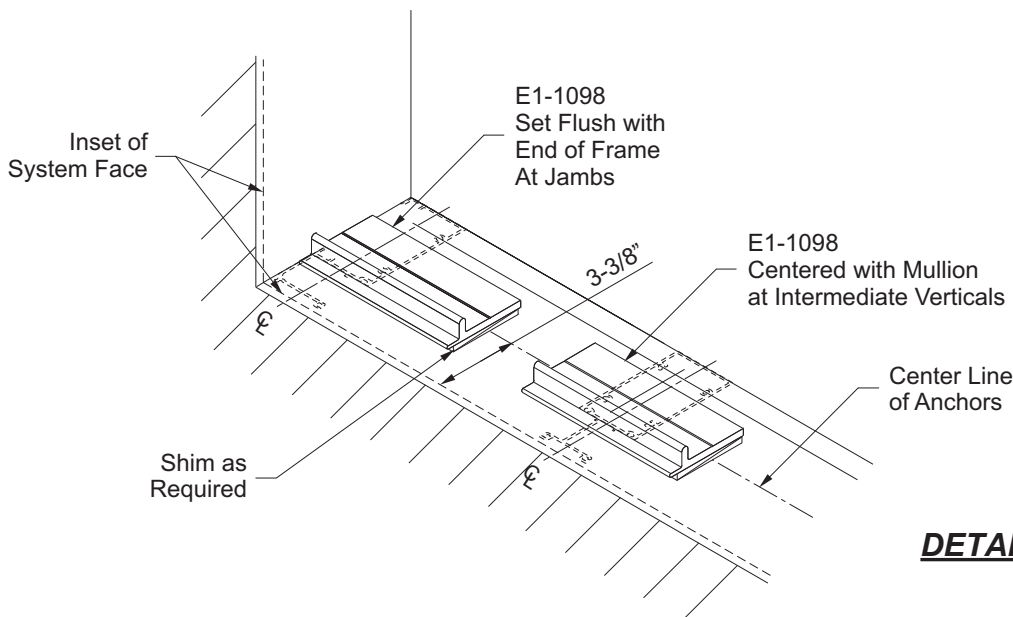

DETAIL 29

FRAME INSTALLATION

STEP 18 (Continued) INSTALL CONTINUOUS HEAD & SILL FRAMES USING OPTIONAL HEAD & SILL ANCHORS

Install Optional Head Anchor, E1-1097

- Predrill head anchors, E1-1097, for appropriate anchor fasteners*.
- Slide the head anchors from the ends of the head member and locate anchors flush with the ends of the frame at jambs and centered over the center line of intermediate verticals.
- Temporarily tape the anchors in place to prevent slipping during installation.

Note: *Refer to approved shop drawings or contact YKK AP for anchor size, quantity, and location.

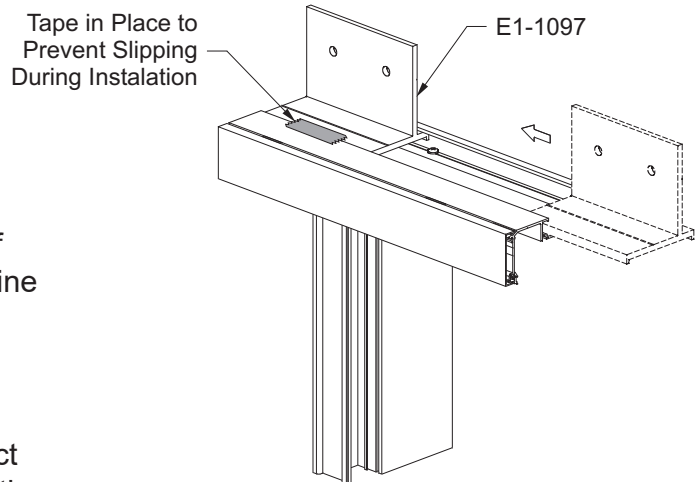

DETAIL 30

See **Detail 30**.

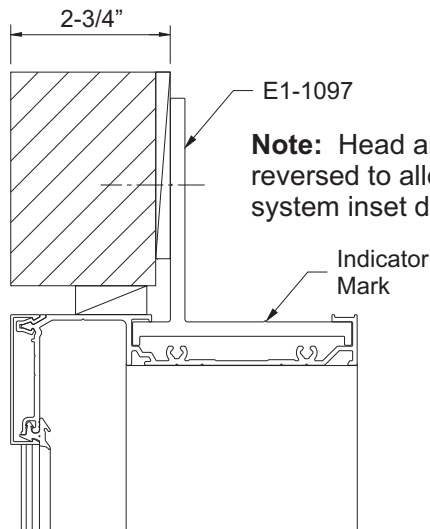

Note: Head anchors may be reversed to allow for different system inset depths.

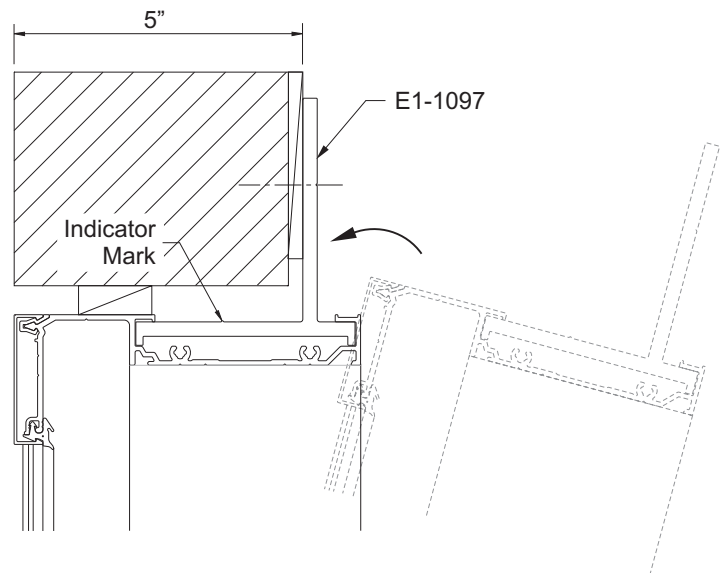

Install Frame Into Opening

- Carefully rotate the assembled frame into the opening, engage the sill member with the sill anchor, and continue rotating the frame into place.
- Shim the jambs and head anchors to ensure that the frame is installed plumb and true.
- Secure head anchors to the structure with anchor fasteners as called out in approved shop drawings.

See **Detail 31**.

DETAIL 31

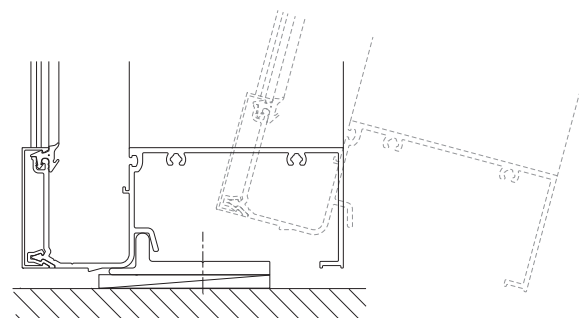

FRAME INSTALLATION

STEP 19
SEAL THE FRAMES

- Apply sealant to all vertical/horizontal joints at the glazing pockets and also where the face of the mullions meet the face covers.
 - Tool the sealant to ensure a watertight joint.
- See **Detail 32**.

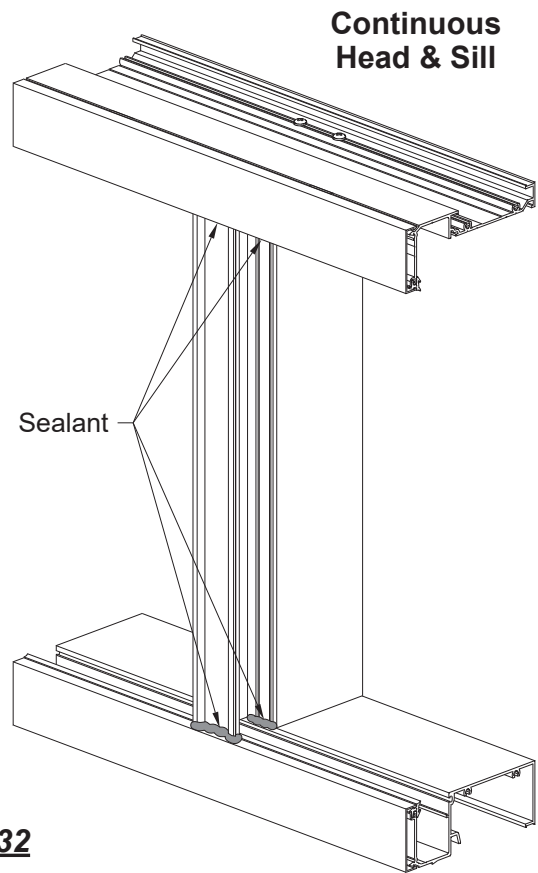
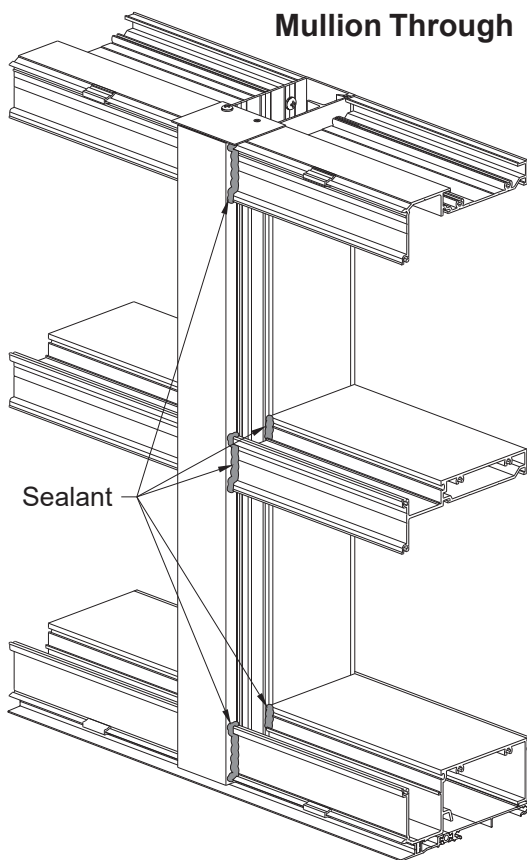

DETAIL 32

- Attach the remainder of the face covers, except for intermediate horizontal covers for SSG frames, using the same techniques shown in **Step 10**.
- For continuous head and sill SSG frames with intermediate horizontals, go to **Step 17**.
- For continuous head and sill captured frames with intermediate horizontals, install the vertical covers first. Then seal the intermediate horizontal to the vertical cover as shown above for mullion through frames prior to installing the intermediate horizontal face covers.

FRAME INSTALLATION

STEP 20 INSTALL WATER DEFLECTORS

The installation of a water deflector, E2-0047, at the ends of every intermediate horizontal is required to divert water away from the insulated units.

- Clean and dry off the glazing pocket of each horizontal at the ends.
 - Peel off the protective paper and install the water deflector at the end of the horizontal.
 - Position the vertical leg of the deflector against the end of the horizontal.
 - Apply and tool sealant along the edges of the water deflector down onto the horizontal.
- See **Detail 33**.

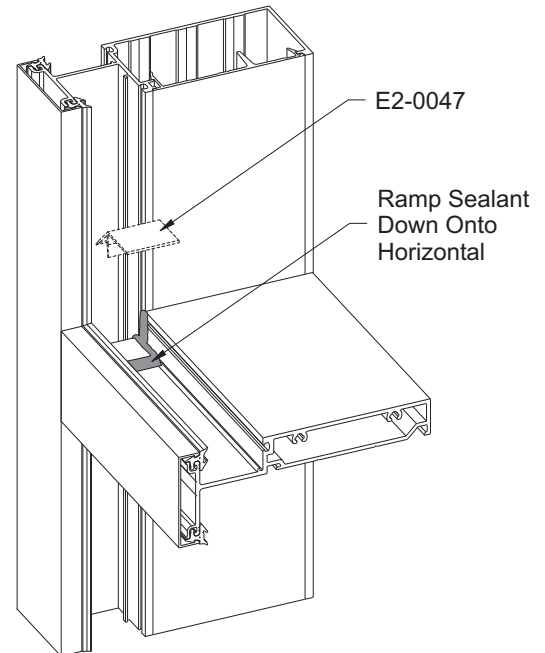

DETAIL 33

STEP 21 INSTALL HORIZONTAL BRIDGE (For SSG Mullions Only)

YWE 60 T requires the installation of horizontal bridge, E1-1090, to bridge the gap between intermediate horizontals at the SSG mullion.

- Clean and dry off the glazing pocket of each horizontal at the ends.
 - Peel away the protective paper on the underside of the bridge.
 - Rotate the bridge into place, aligning the back edge of the bridge with the snap leg.
 - Apply and tool sealant at all bridge to horizontal and vertical joints to ensure a watertight seal.
- See **Detail 34**.

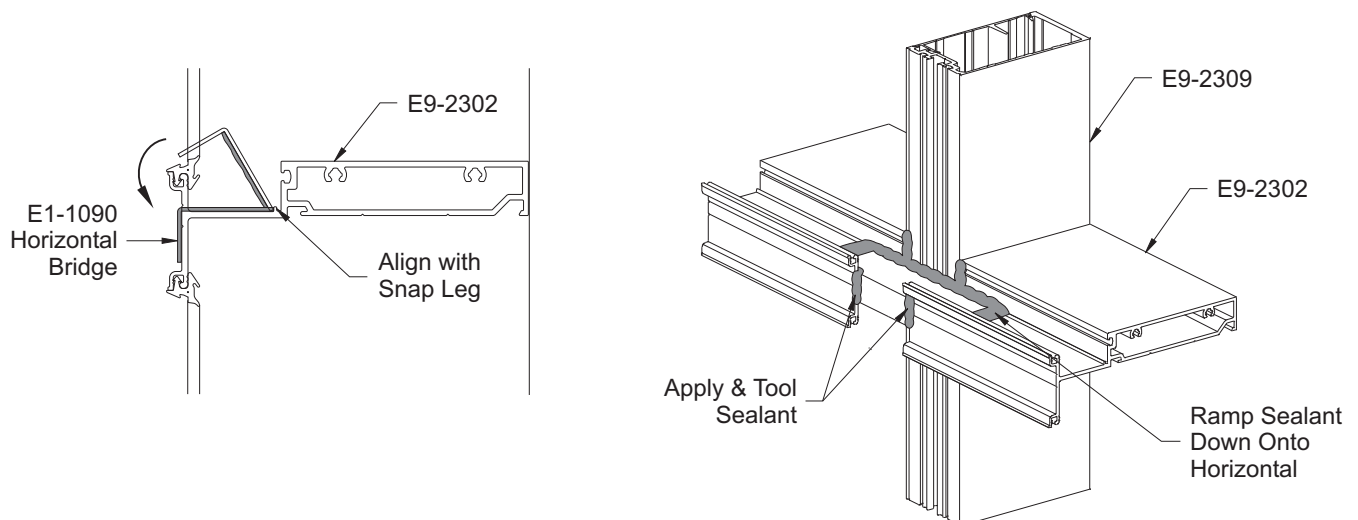

DETAIL 34

FRAME INSTALLATION

STEP 22
INSTALL HORIZONTAL FACE COVERS
FOR SSG MULLION APPLICATIONS

- Snap on horizontal face covers as shown previously in **Step 10**.
- At face cover expansion joints, slide the face cover splice sleeve, E3-0039, into the first face cover prior to snapping on the next one.
- Center the 1/2" expansion joint about the SSG mullion.
- Apply and tool sealant to the expansion joint at the top and face only.

Note: Leave the bottom of the face cover open to allow the frame to weep properly.

See **Detail 35**.

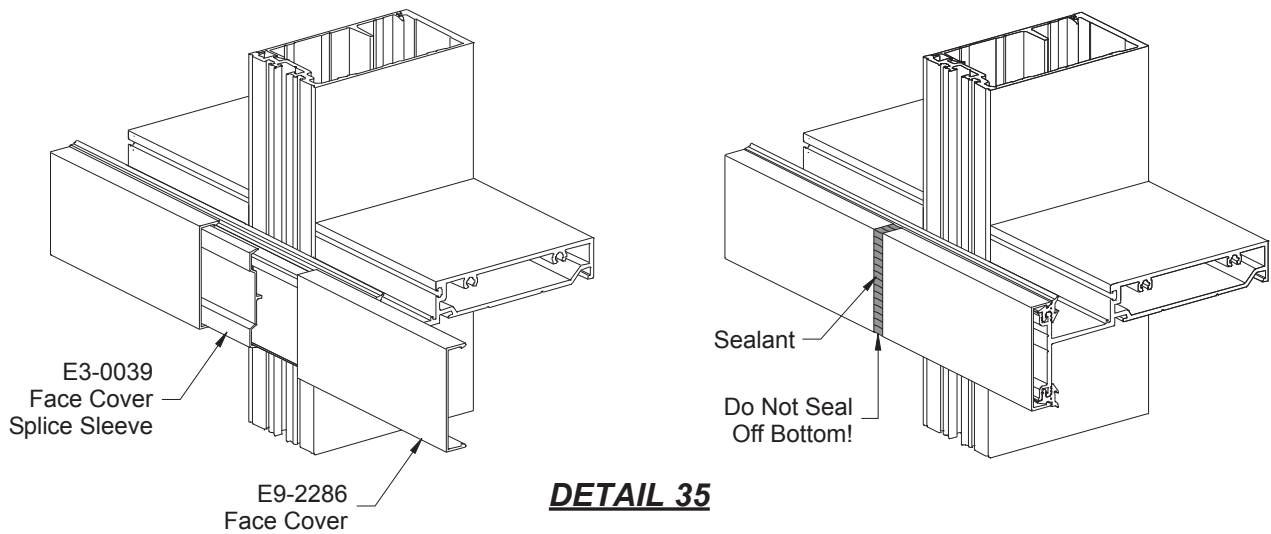

DETAIL 35

Head and intermediate horizontal face covers that run across SSG mullions without being spliced must have weep holes drilled on the underside of the cover to allow the frame to weep properly.

- Drill a 5/16" diameter weep hole on the underside of the cover centered with the SSG mullion.

See **Detail 36**.

DETAIL 36
 Intermediate
 Horizontal Shown
 Head Similar

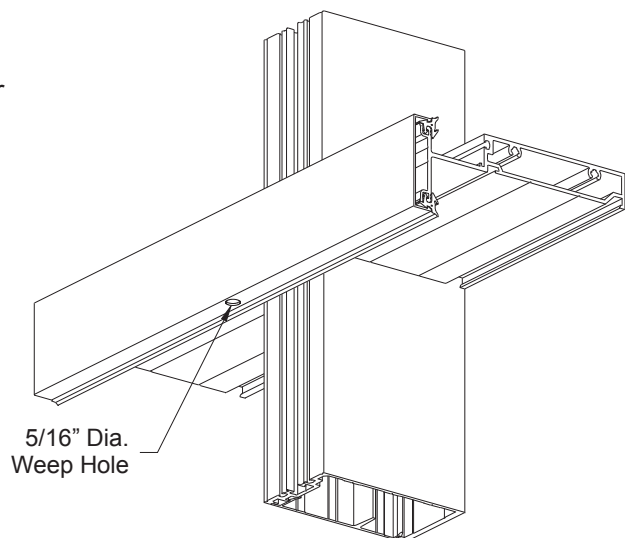

FRAME INSTALLATION

STEP 23
APPLY PERIMETER SEALANT

- Install backer rod around the perimeter of the frame between the frame and the structure.
 - Apply perimeter sealant and tool the sealant to ensure a watertight joint.
- See **Detail 37**.

Note: Interior perimeter seal must be applied to ensure YKK AP tested air and water infiltration performance.

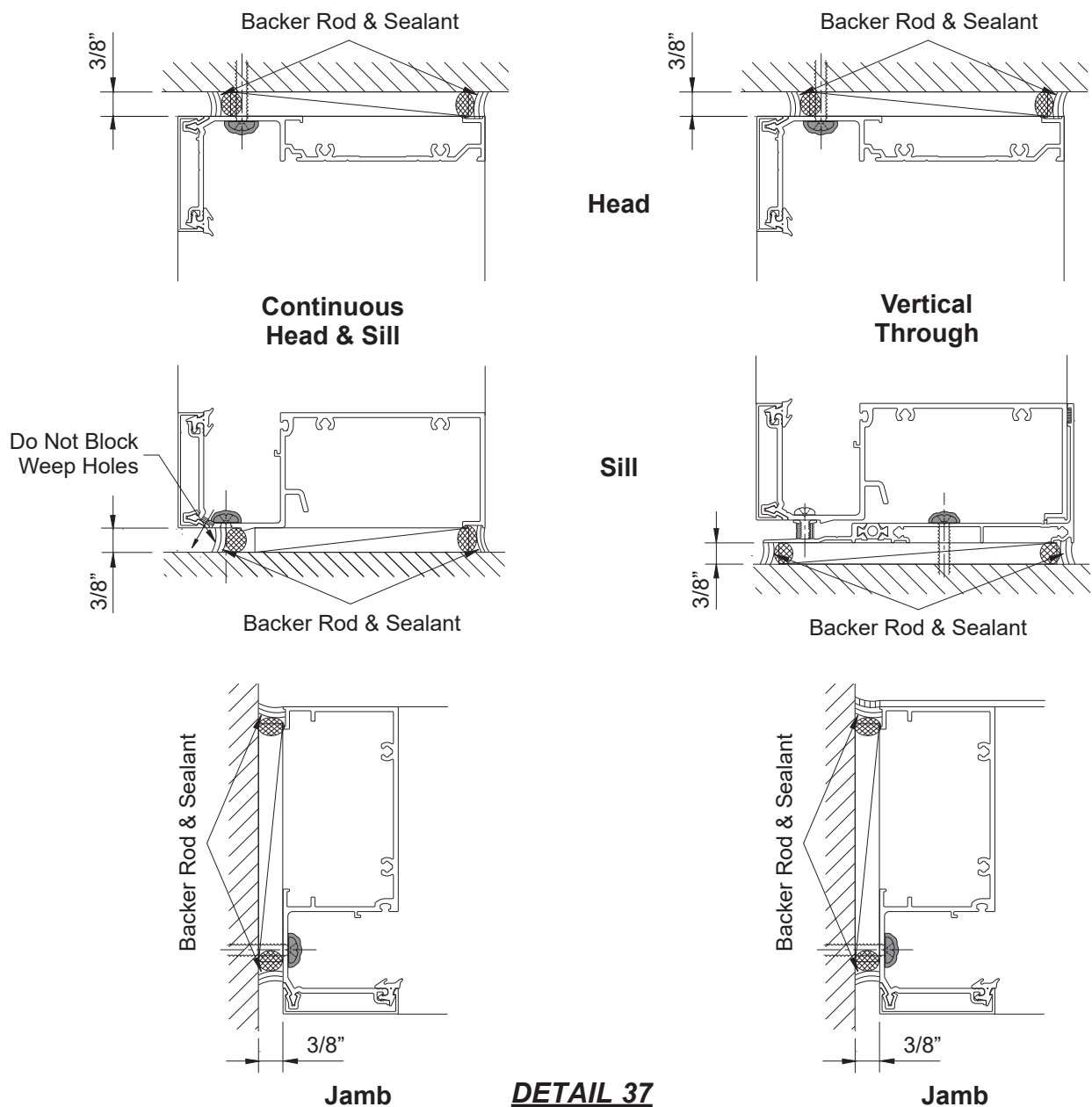

FRAME INSTALLATION

STEP 24
INSTALL 1/4" GLAZING ADAPTORS
(When Required)

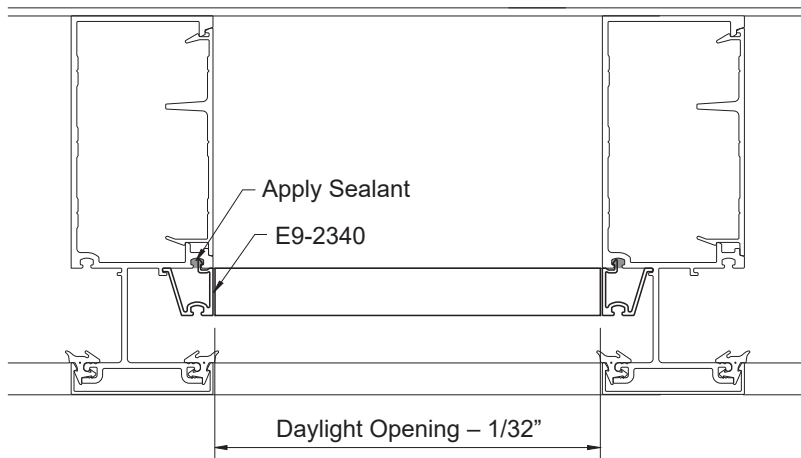

Notch leg of vertical adaptor for continuous head and sill frames

DETAIL 38

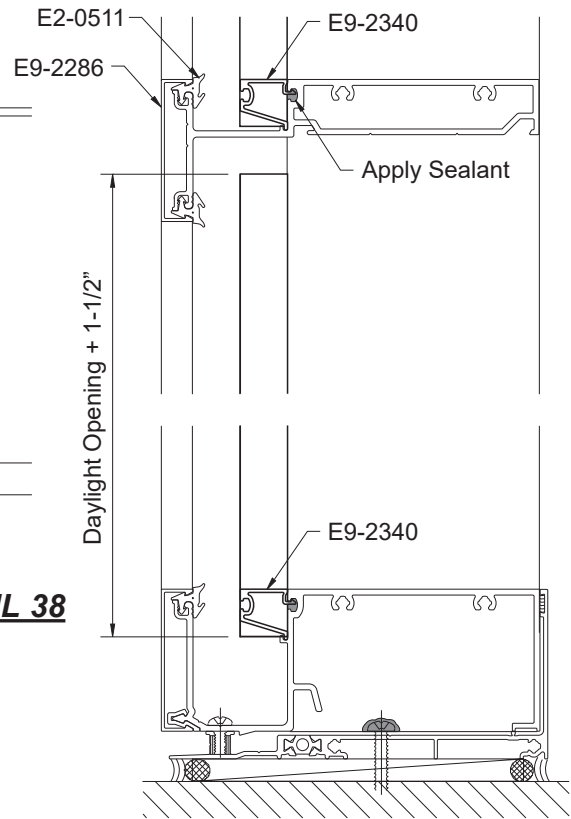

- Cut glazing adaptors for verticals:
 Cut Length = Daylight Opening + 1-1/2"
- Cut glazing adaptors for horizontals:
 Cut Length = Daylight Opening - 1/32"
- Run a bead of sealant along the gasket reglet.

Note: For continuous head and sill frames, notch the leg of the vertical adaptor 3/4" at both ends.

- Attach the vertical glazing adaptors first:
- Center the vertical adaptors in the opening.
 - Insert the ball end leg of the adaptor into the recess at the back of mullion tongue and rotate the snap leg into the reglet.

- Attach the horizontal glazing adaptors last:
- Apply sealant to the ends of the horizontal glazing adaptors.
 - Install the horizontal adaptors.

See **Detail 38**.

- Tool the excess sealant at the intersections of the adaptors to completely seal the joint.

See **Detail 39**.

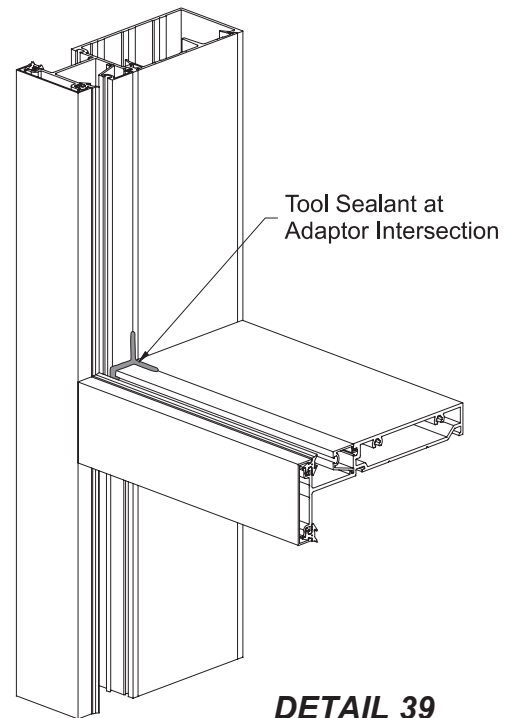

DETAIL 39

FRAME INSTALLATION

STEP 24 (Continued) INSTALL 1/4" GLAZING ADAPTORS FOR SSG MULLIONS (When Required)

- Cut SSG 1/4" glazing adaptor, E9-2346, to the daylight opening plus(+) 1-1/2".
- Position the adaptor in place against the face of the SSG vertical and install with PC-1012 fasteners 2" from each end and then 18" on center.
- Seal all screw heads.

- Install the horizontal 1/4" glazing adaptors as shown on the previous page.
- Seal the ends of the horizontal adaptors to the vertical adaptors with sealant.

See **Detail 40**.

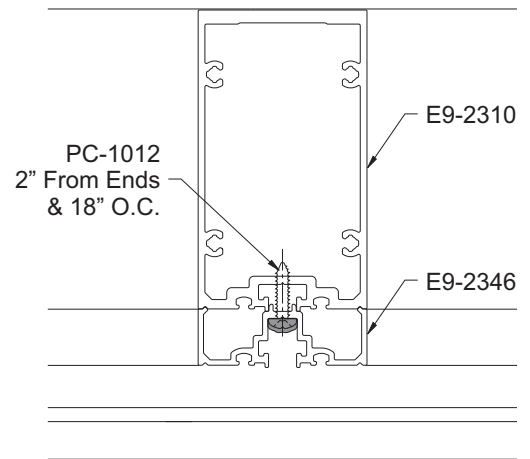

DETAIL 40

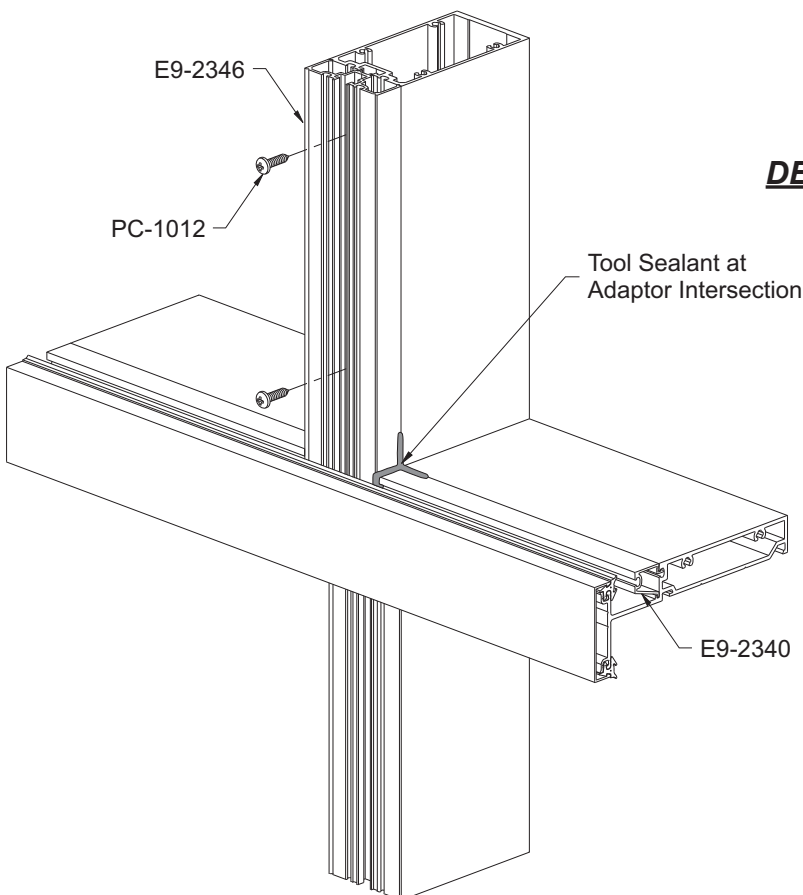

GLAZING

STEP 25 INSTALL GLASS FOR STANDARD GLAZING

Determine the glass size:

	Width	Height
Standard Glazing	D.L.O. + 1"	D.L.O. + 1"

-Install setting blocks at 1/4 points or according to engineering calculations.

At intermediate horizontals: E2-0178.

At sills: E2-0178 with setting block chair E1-1080.

Note: Continuous sills also require that weep baffles, E2-0099, be installed at each setting block chair and over the weep holes.

-Install side blocks, E2-0134, in the shallow glazing pocket of each vertical at the midpoint of the vertical daylight opening.

-Carefully install glass into the frame making sure that it is properly aligned with the setting and side blocks.

See **Detail 41**.

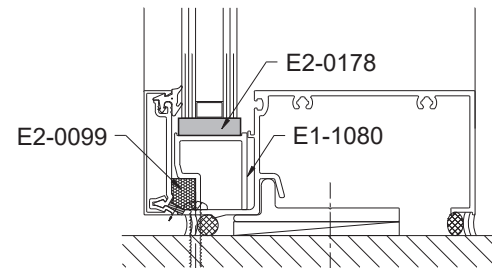
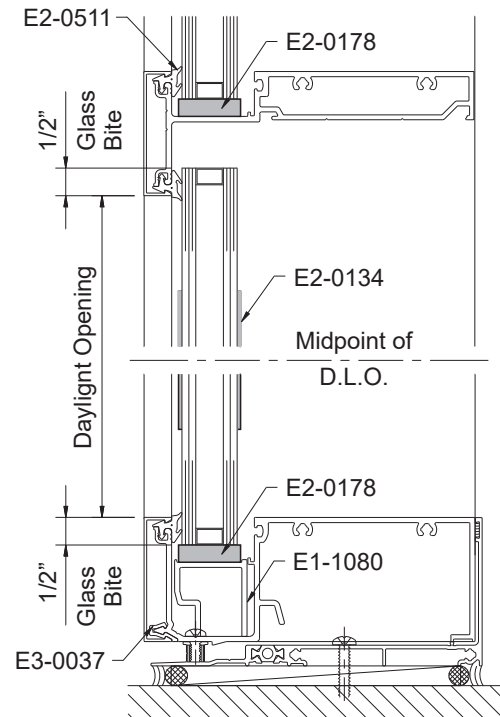

DETAIL 41

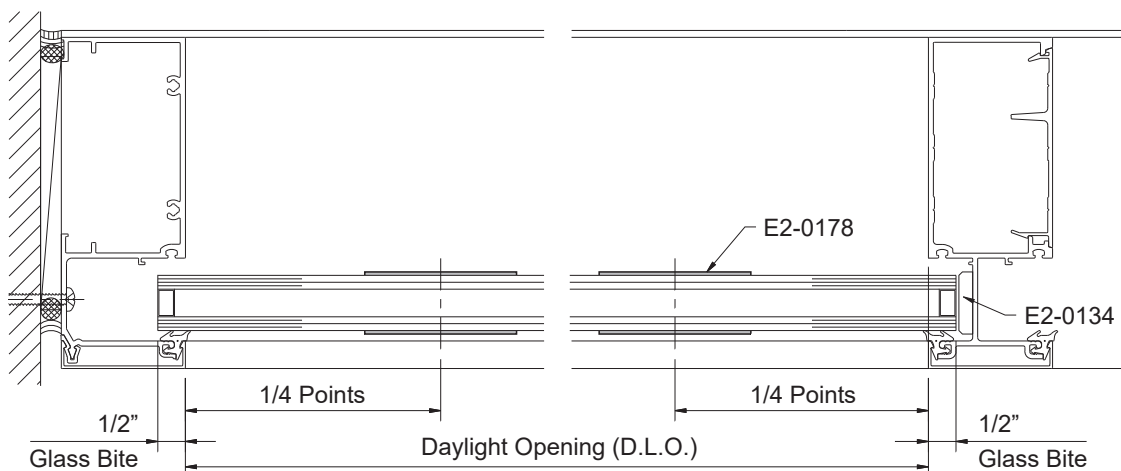

GLAZING

STEP 25 (Continued) INSTALL GLASS FOR STANDARD GLAZING

Install Anti-Walk Blocks:

Anti-walk blocks must be installed in the vertical deep glazing pocket of each lite centered along the daylight opening:

E2-0520 for the jambs.

E2-0519 for intermediate verticals.

-Flatten the anti-walk block against the surface of the glass and push it into the opening between glass and the mullion until it is released into the glazing pocket.

See **Detail 42**.

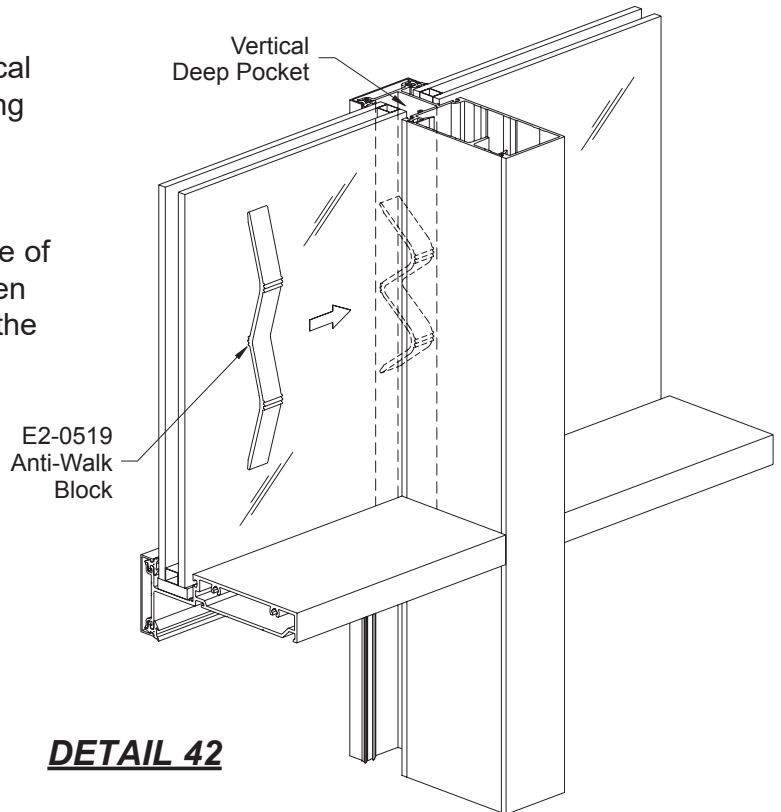
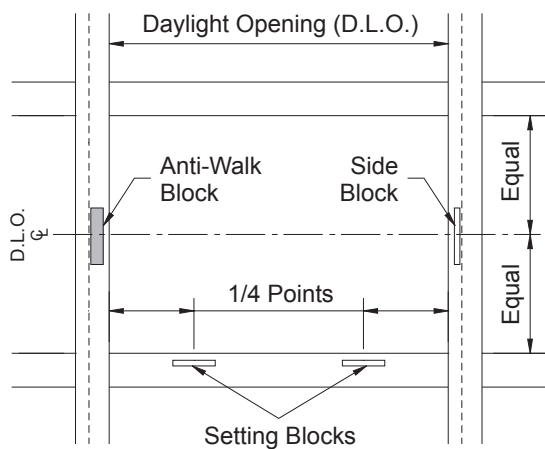

DETAIL 42

Install Glass Stops:

-Apply sealant to each end of the glass stops and snap them into position.

-Apply and tool sealant behind the glass stop at the verticals to ensure a watertight seal.

-Using PC-1008 fasteners, screw the glass stop to the frame at 1/4 points.

See **Detail 43**.

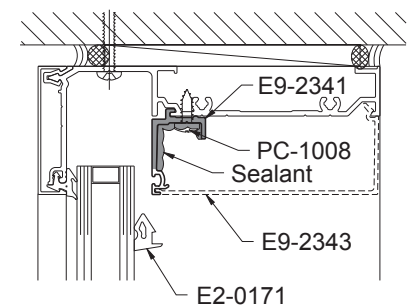

Install Interior Glazing Gaskets:

-Cut vertical & horizontal glazing gaskets to D.L.O. plus(+) 3/16" for each foot of length.

-Install vertical glazing gaskets first. Insert the ends and the middle of the gasket. Insert the rest of the gasket starting from the middle and work towards the ends.

-Install horizontal gaskets using the same technique.

-Install interior trim covers, E9-2343, in vision areas only.

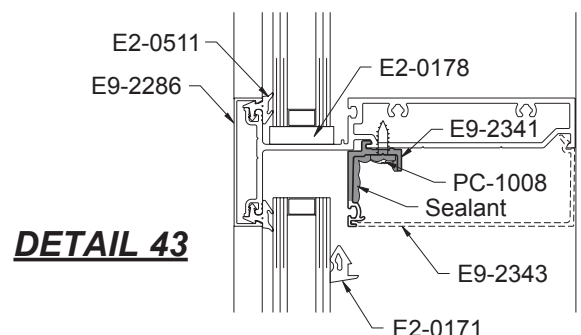

DETAIL 43

GLAZING

STEP 26 INSTALL GLASS FOR STRUCTURAL SILICONE GLAZING

Determine the glass size:

	Width	Height
Jamb to SSG	D.L.O. + 1-3/8"	D.L.O. + 1"
SSG to SSG	D.L.O. + 1-3/4"	D.L.O. + 1"

-Install setting blocks at 1/4 points or according to engineering calculations.

At intermediate horizontals: E2-0178.

At sills: E2-0178 with setting block chair E1-1080.

Note: Continuous sills also require that weep baffles, E2-0099, be installed at each setting block chair and over the weep holes.

-Carefully install the first lite of glass from the interior starting at one of the jambs.

-Slide the glass into the glazing pocket of the jamb until it clears the SSG mullion; slide the glass back 7/8" over in front of the first SSG mullion.

-Make sure that the glass is properly aligned with all setting blocks.

-YKK AP recommends the installation of anti-walk block, E2-0520, at the midpoint of each jamb glazing pocket.

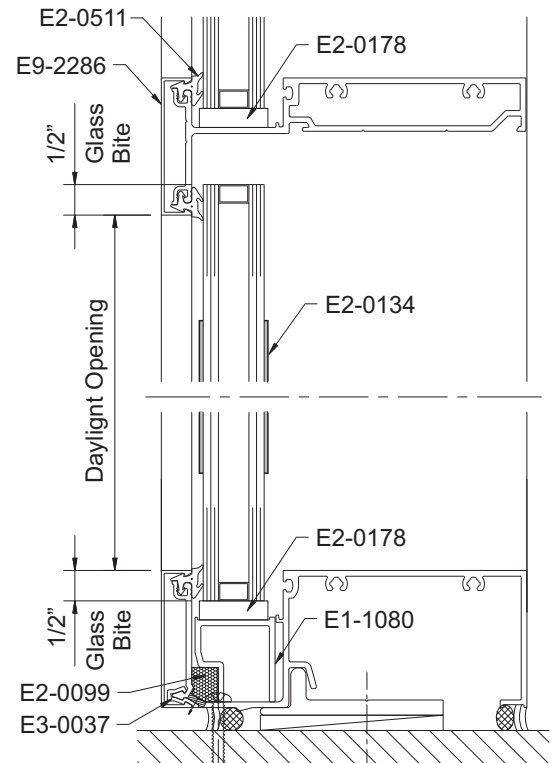

See **Detail 44.**

DETAIL 44

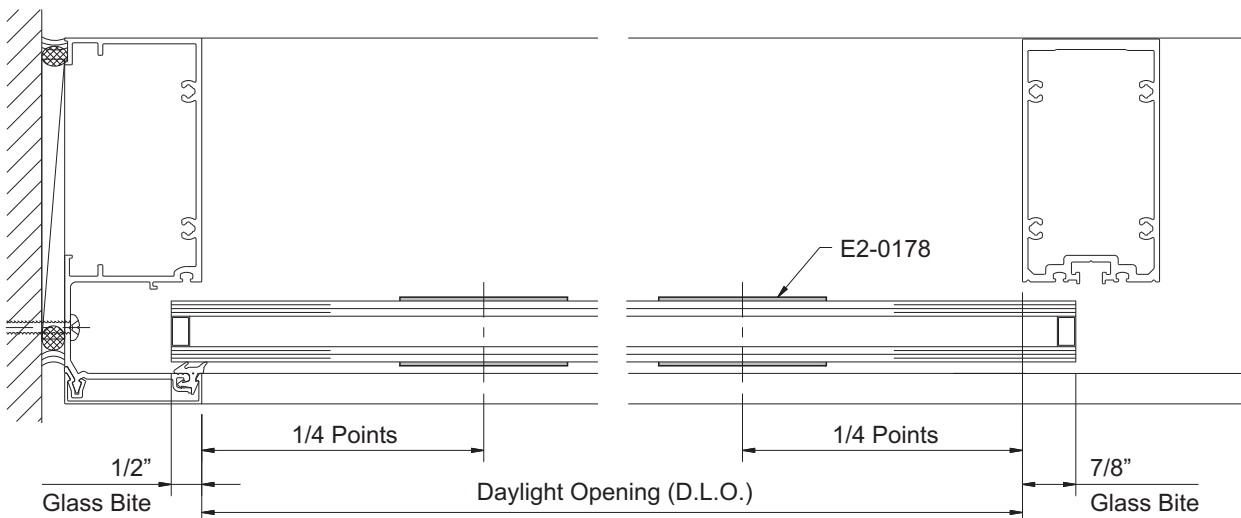

GLAZING

STEP 26 (Continued)

INSTALL GLASS FOR STRUCTURAL SILICONE GLAZING

Install Glass Stops:

-Apply sealant to each end of the glass stops and snap them into position. Fasten with (2) PC-1008 screws.

-Apply and tool sealant behind the glass stop at the verticals to ensure a watertight seal.

See **Detail 45**.

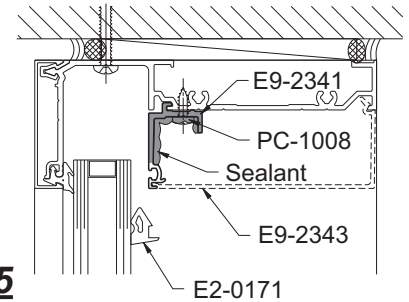

Install Interior Glazing Gaskets & Spacers:

-Cut vertical glazing spacers to the glass height plus(+) 3/16" for each foot of height.

-Cut vertical & horizontal glazing gaskets to D.L.O. plus(+) 3/16" for each foot of length.

-Using a putty knife, carefully install the silicone spacer, E2-0521, behind the first lite installed.

Start at the bottom and work your way up.

-Install jamb glazing gaskets next. Insert the ends and the middle of the gasket. Insert the rest of the gasket starting from the middle and work towards the ends.

-Install horizontal gaskets using the same technique.

-Install interior trim covers, E9-2343, in vision areas only.

DETAIL 45

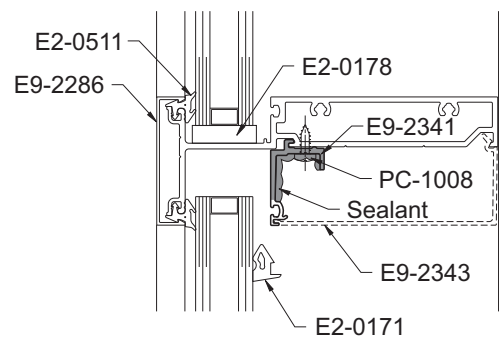

Note: Silicone compatible gaskets must be used when using SSG verticals.

Install Temporary Glass Retainers:

-From the open side reach around the vertical, insert the temporary glass retainers, E3-0001 for 1" glazing or E3-0006 for 1/4" glazing, and twist them 90° clockwise to engage.

Locate temporary glass retainers 18" to 24" on center. See **Detail 46**.

-Install the next lite of glass and center it to maintain a 1/2" joint between lites.

-Install the glazing spacers, glazing gaskets, and temporary glass retainers as instructed above.

-Repeat this step until all lites of glass have been installed.

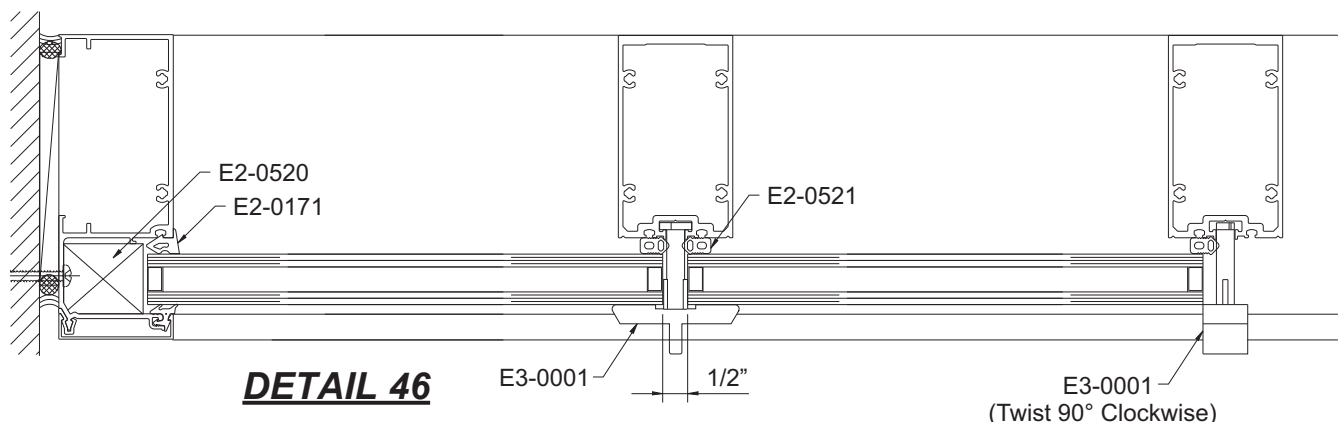

DETAIL 46

GLAZING

**STEP 27
APPLY INTERIOR STRUCTURAL SILICONE**

- Run a piece of masking tape vertically on the glass with one edge in line with the side of the mullion.
- Run another piece of masking tape vertically along the edge of the vertical nearest to the glass.
- Check to make sure that the structural silicone spacers are 3/8" from the edge of the mullion in order to obtain the proper structural joint size.

See **Detail 47**.

DETAIL 47

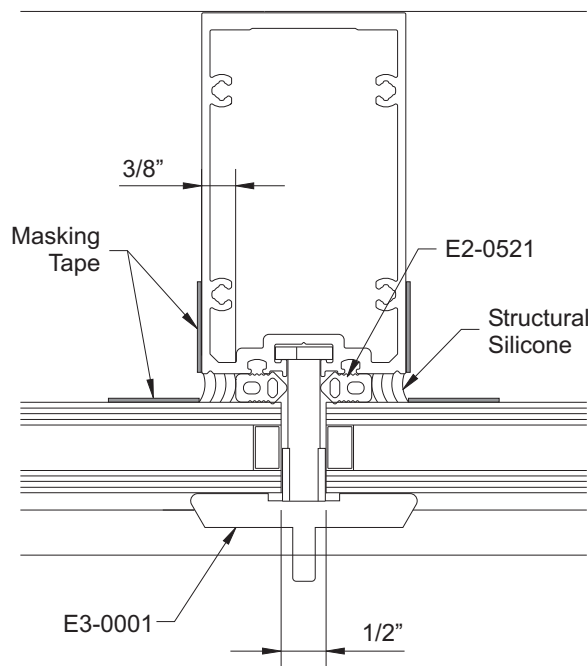

- Prior to applying the structural silicone, clean all contact surfaces using an approved cleaner.
- Apply structural silicone from the bottom to the top of the joint.
Use positive pressure to completely fill the cavity between the glass and mullion.
- Using a nylon spatula or other non-scratching implement, tool the silicone immediately after running the vertical joint. Exert positive pressure while tooling to ensure that the silicone completely fills the cavity.
- Be careful not to remove too much silicone.
The silicone should make complete contact with the glass and aluminum surfaces.
The finished joint should be flush with the edge of the vertical.

Caution: Do not permit the silicone to skin over before it is tooled.
Immediately remove masking tape after tooling the silicone.

GLAZING

STEP 28 APPLY EXTERIOR WEATHERSEAL

Once the interior structural silicone has cured*, it is necessary to seal the 1/2" wide exterior joint between the lites of glass.

Note: *Please consult sealant manufacturer for recommended cure time.

- Remove the temporary glass retainers and insert a backer rod between the lites of glass.
- Clean all contact surfaces with an approved cleaner and apply masking tape to both vertical edges of the glass.
- Starting at the bottom of the lite, apply structural silicone into the joint between the lites of glass. Apply moderate pressure so that the void is completely filled.

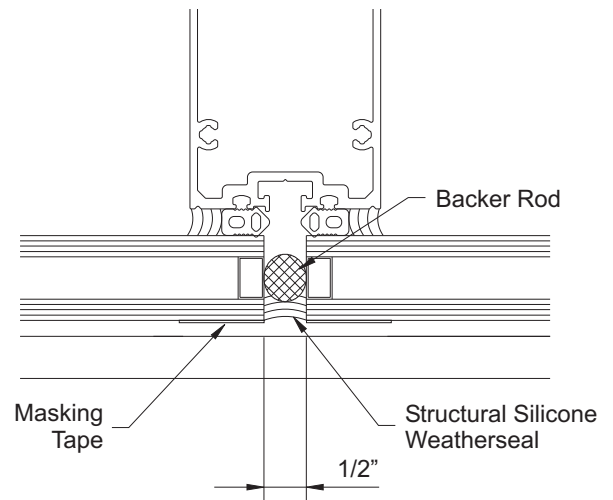

DETAIL 48

Caution: Be careful not to puncture the backer rod or push it out of the way.

-Using a nylon spatula or other non-scratching implement, tool the silicone immediately after running the vertical joint. Exert positive pressure while tooling to ensure that the silicone completely fills the cavity.

-Be careful not to remove too much silicone. The silicone should make complete contact with the glass and aluminum surfaces. The finished joint should be flush with the edge of the vertical.

See **Detail 48**.

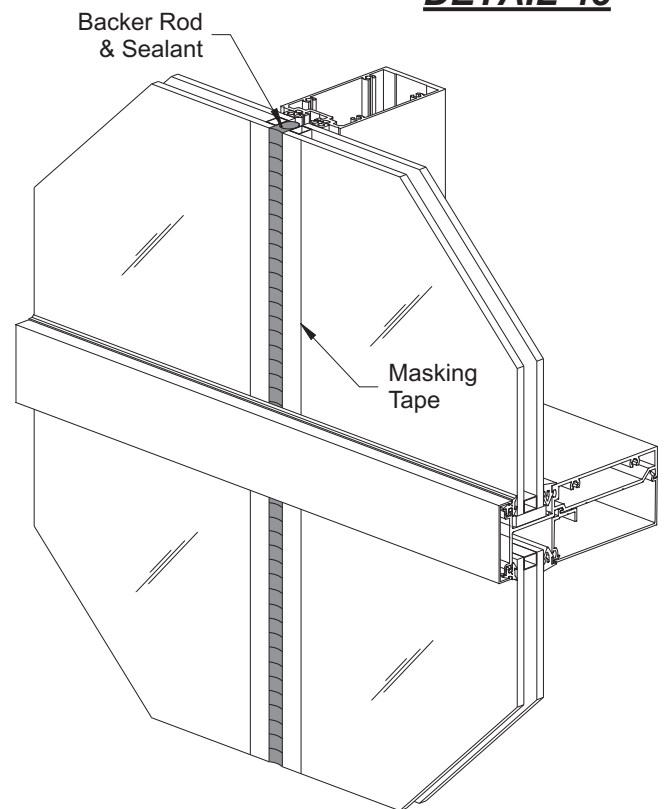

Caution: Do not permit the silicone to skin over before it is tooled. Immediately remove masking tape after tooling the silicone.

GLAZING

STEP 29 (When Required) REGLAZING INSTRUCTIONS

Reglaze from the Interior

- Remove the interior cover by pushing it forward and down to unsnap it.
- Remove the glass stop and glazing gaskets.
- Replace the broken glass with a new lite of same size.
- Reglaze the lite following the directions previously shown in **Step 25** or **Step 26**.

Reglaze from the Exterior

- Remove all broken glass, exterior and interior glazing gaskets, and interior glass stop.
- Carefully pry off the horizontal face cover above the damaged lite.
- The bottom exterior leg of the horizontal or head member must be cut off along the bottom "V-Groove" on the face of the mullion.

See **Detail 49**.

Warning: Be careful not to scar the vertical face cover when making this cut.

- Drill 0.161" diameter holes in the reglaze adaptor, E9-2264, along the "V"-Groove 3" from each end and at the midpoint.
- Apply sealant to the ends of the interior glass stops and attach them to the horizontal members.
- Seal the area behind the interior glass stop.
- Install new push-in glazing gasket, E2-0196, instead of roll-in gasket E2-0171 in the interior reglets.
- Install setting & side blocks, glass, and anti-walk blocks as previously shown in **Steps 25** or **26**; however, the glass is now installed from the outside.
- Position the reglaze adaptor into place as shown and attach it to the head or horizontal member with #10 x 5/8" TEK screws through the pre-drilled holes. See **Detail 50**.

Warning: Reglaze adaptors must be properly aligned with the head/horizontal members in order for the face covers to snap in properly.

- Install new exterior glazing gasket, E2-0511, and face covers as previously shown in **Step 10**.

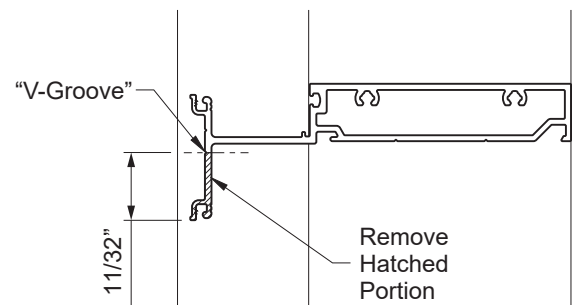
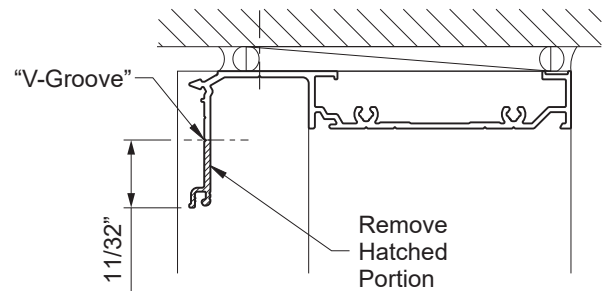

Detail 49

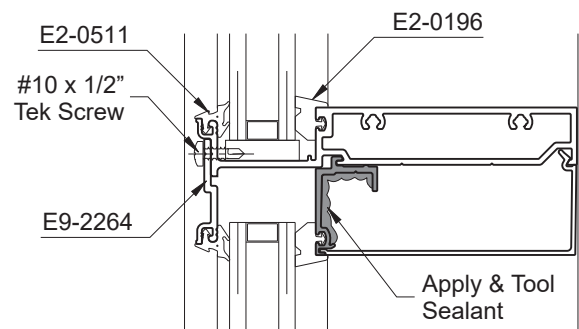
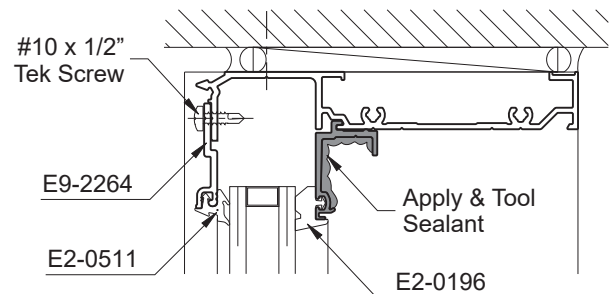

Detail 50

CORNER INSTALLATION

Install Corner Mullions:

- Attach horizontal members to standard verticals as shown before in **Step 11**. Attach the other end of the horizontals to the the corner mullions or corner fillers, E9-2314, for 90° inside and both 135° corners using the same technique.
- Snap the corner framing members together to form the corner assemblies.

Note: Corner framing members may be attached with PC-1008 fasteners as shown.

- Carefully move the corner assembly into place and snap it into the rest of the frame one side at a time.

See **Details 1C & 2C**.

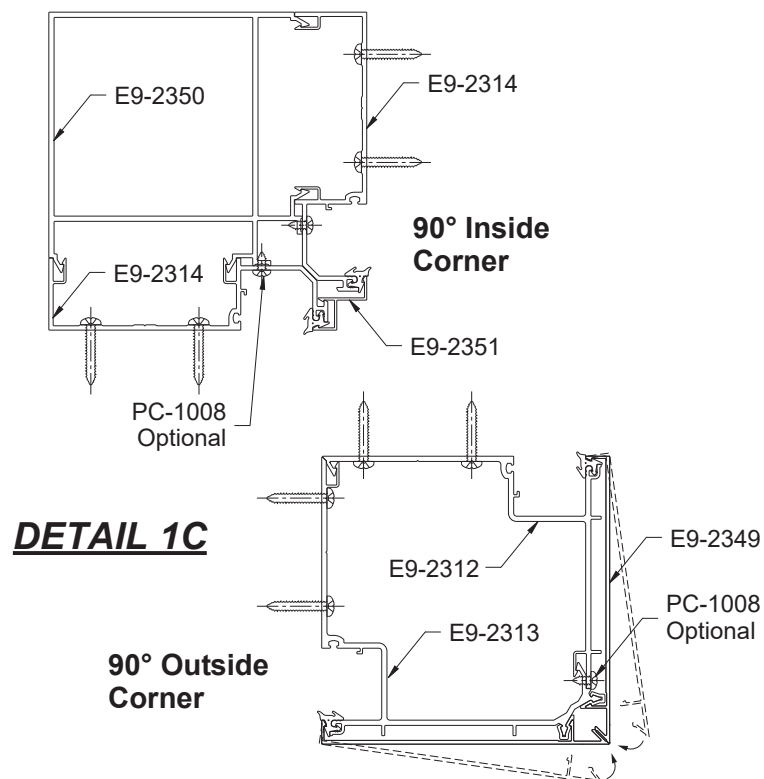

CORNER INSTALLATION

**STEP 1C (Continued)
INSTALL STANDARD CORNER MULLIONS**

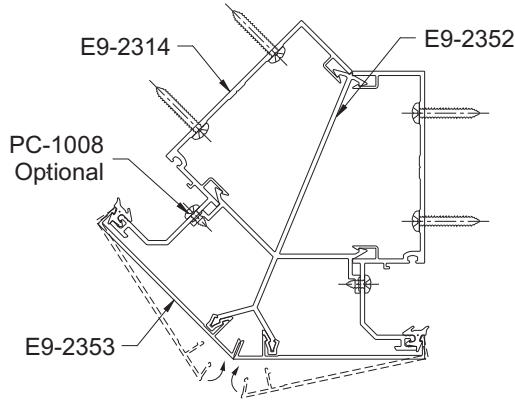

135° Outside Corner

DETAIL 2C

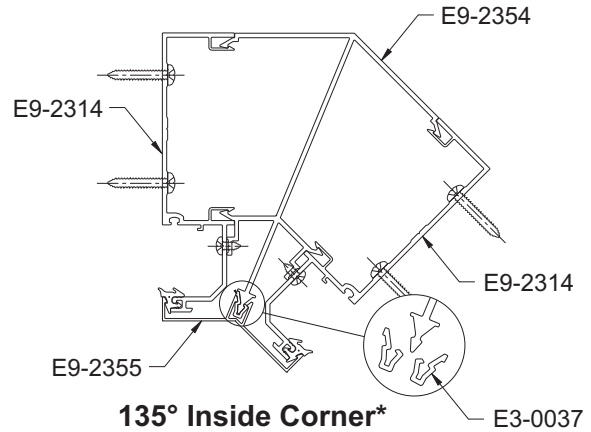

135° Inside Corner*

**STEP 2C
INSTALL 90° SSG CORNER MULLIONS**

Fabricate Horizontal Members:

- Miter the head, horizontal, and sill members for the corners at a 45° angle. See shop drawings for cut lengths.
- Layout hole locations for attachment of horizontal members to corner mullion shear clips.
- Drill 0.189" diameter (#12 drill bit) holes at each location marked on the head and horizontal.
- Drill 0.236" diameter (#B drill bit) holes at each location marked on the sill.
- Sill holes must be countersunk for #12 fasteners.

See **Detail 3C**.

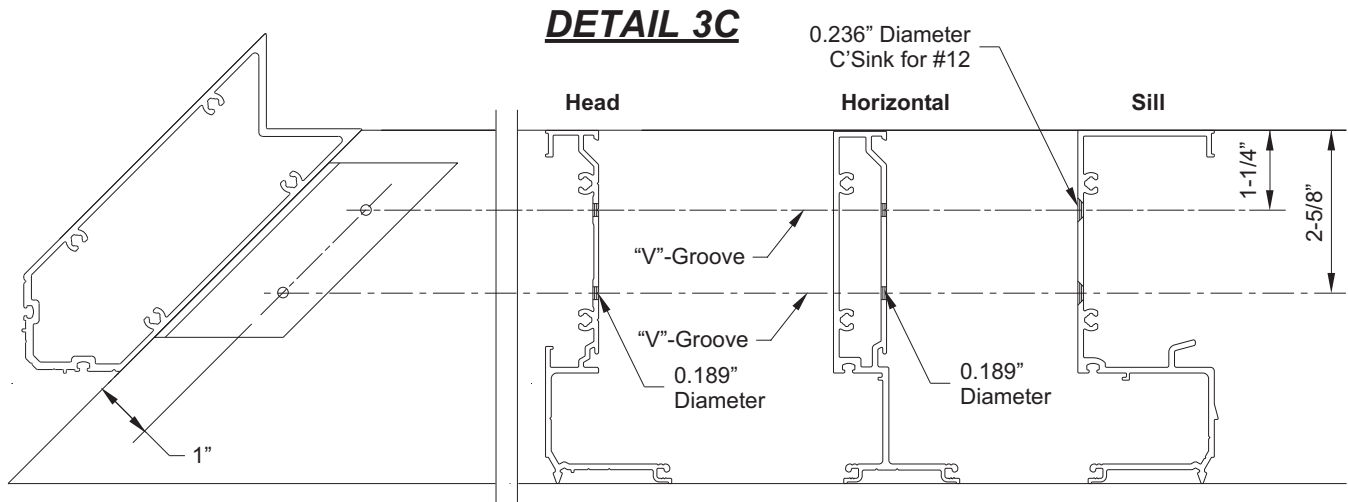

CORNER INSTALLATION

STEP 2C (Continued)
INSTALL 90° SSG CORNER MULLIONS

Fabricate Horizontal Face Covers & Glass Stops:

- Miter horizontal face covers and glass stops for the corners at a 45° angle. See shop drawings for cut lengths.
- Glass stops must be notched to clear the shear clips. Notch the glass stops 3-1/8" from the miter and 1-1/2" from the intermediate mullion end. Cut both notches 1/2" deep from the interior edge of the glass stop. See **Detail 4C**.

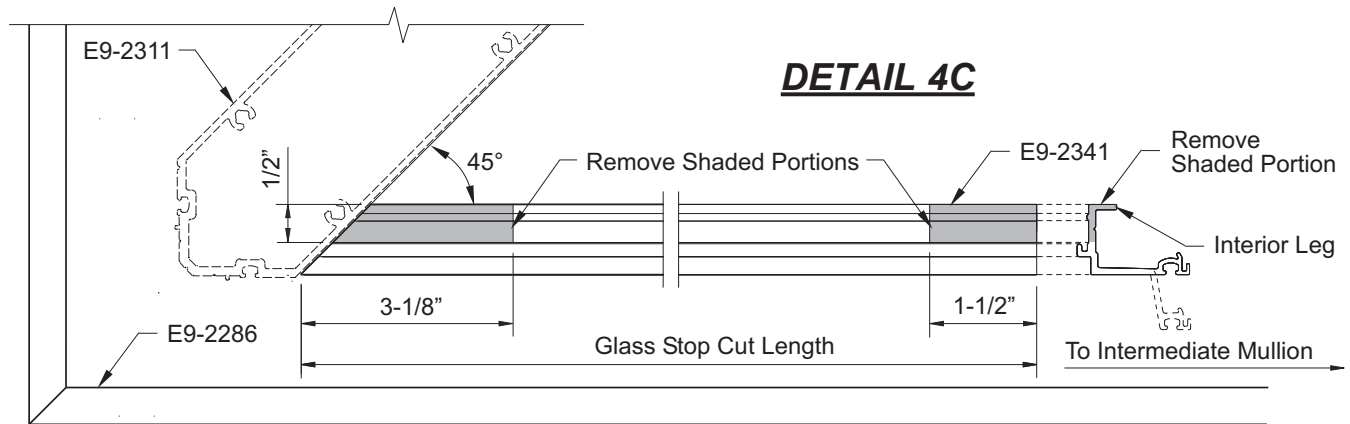

Fabricate & Install 90° SSG Corner Mullion:

- Cut 90° outside SSG vertical, E9-2311, to the frame height determined in **Step 1**.
- Layout hole locations as shown below for attachment of shear clips, E1-1078 & E1-1079.
- Head and horizontal attachment holes on the shear clips must be redrilled to 0.236" dia. clear holes for PC-1208 fasteners.
- Attach the shear clips to the mullion with (2) PC-1208 fasteners per clip.
- Position the corner mullion into place and attach the horizontals to the shear clips.
- Note:** Sill members are attached by countersunk FC-1208 fasteners.

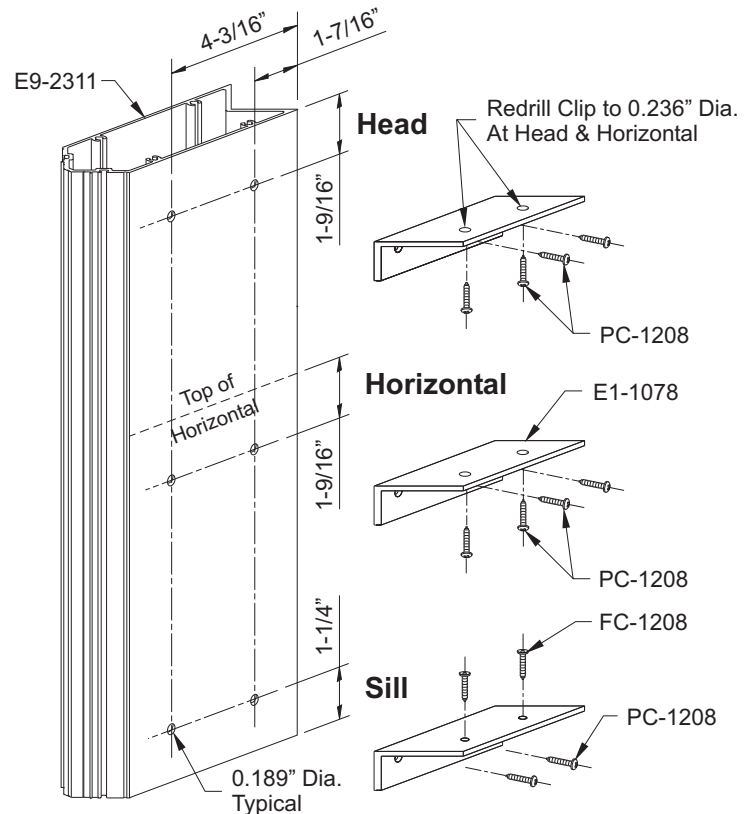

See **Detail 5C**.

DETAIL 5C

CORNER INSTALLATION**STEP 3C
INSTALL HORIZONTAL BRIDGES
AT 90° OUTSIDE SSG CORNER**

Horizontal bridges, E1-1095 (RH) and E1-1096 (LH), must be installed to close the gap between horizontals at 90° SSG corners.

- Peel away the protective paper underneath the bridges and position them in place.
- Apply and tool sealant to the joint between the bridges and all bridge to horizontal and vertical joints to ensure a watertight seal.
- Ramp the sealant over the edges of the bridges at the glazing pocket.

See **Detail 7C**.

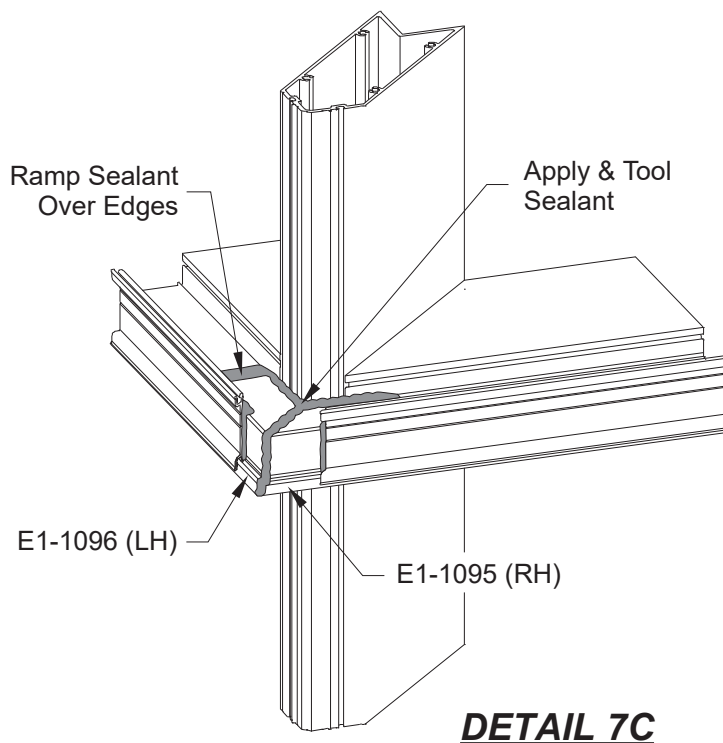
DETAIL 6C**DETAIL 7C**

CORNER INSTALLATION

**STEP 4C
INSTALL CORNER TRIM
AT 90° OUTSIDE SSG CORNER**

- Cut the E9-2550 90° Outside Trim Cover Base and E9-3439 Trim Cover to Daylight Opening (D.L.O.H.) plus (+) 1”.
- Mark hole locations on the trim cover no more than 3” from each end and then 18” on center maximum on both sides along the “V”-groove. Drill 0.189” diameter holes at each hole location.

- Position the trim cover onto the corner mullion centered along the vertical daylight opening and match drill 0.141” diameter holes into the mullion.
- Immediately prior to installation, apply continuous sealant to the trim base as shown in Detail 8C.
- Attach the trim cover to the corner mullion with PC-0806 fasteners.
- Apply and tool sealant to all screw heads.

See **Detail 9C**.

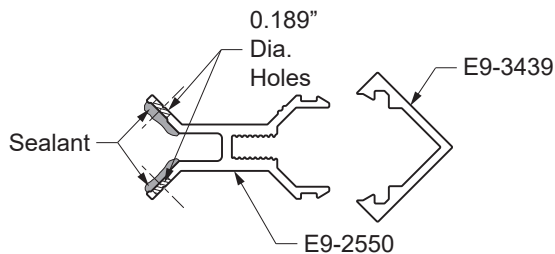
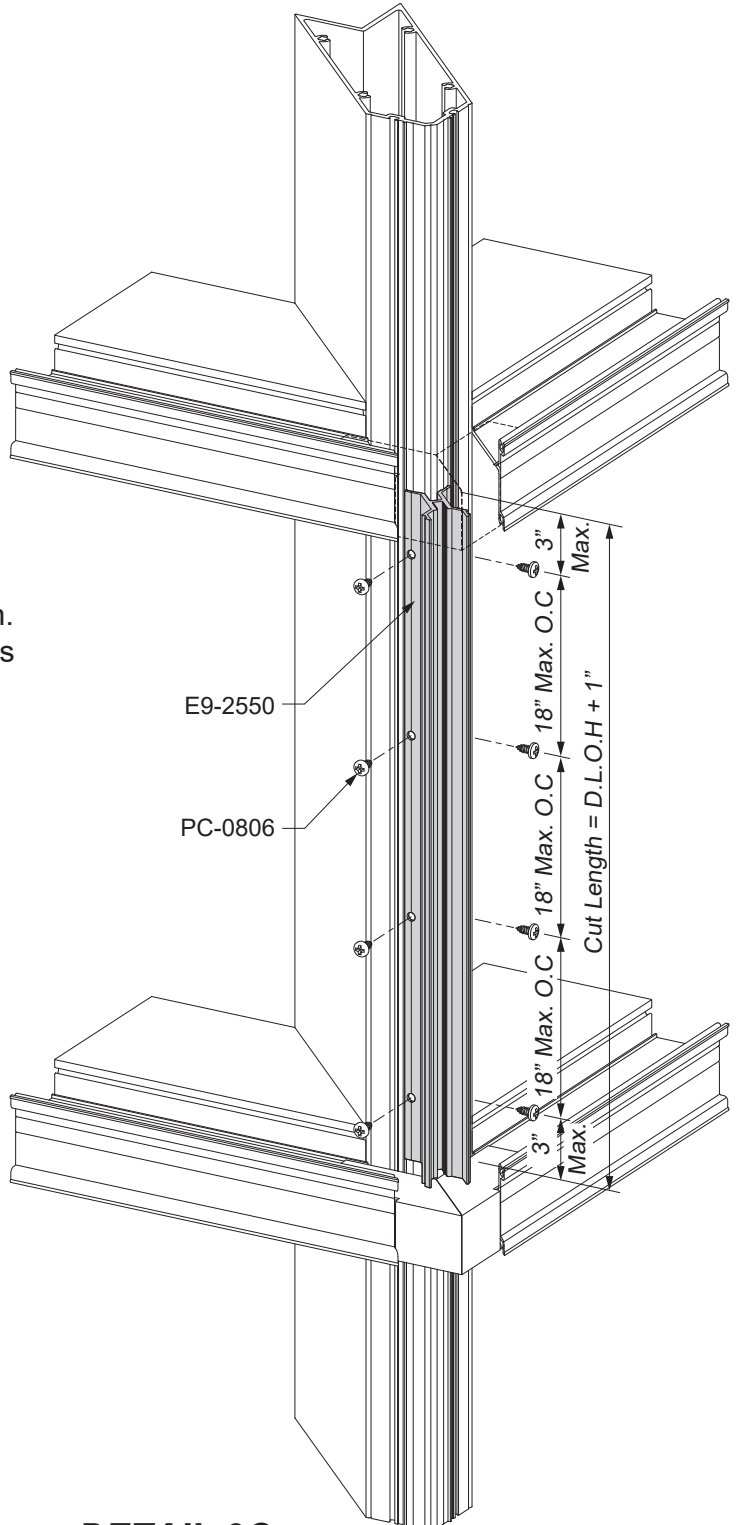

DETAIL 8C

DETAIL 9C

CORNER INSTALLATION**STEP 5C
INSTALL GLASS FOR INSIDE GLAZED
STRUCTURAL SILICONE GLAZING**

-At the 90° corner SSG mullions, use E1-3588 retainers with HM-2516 fasteners, spaced at 2'-0" maximum on center.

See **Detail 10C**.

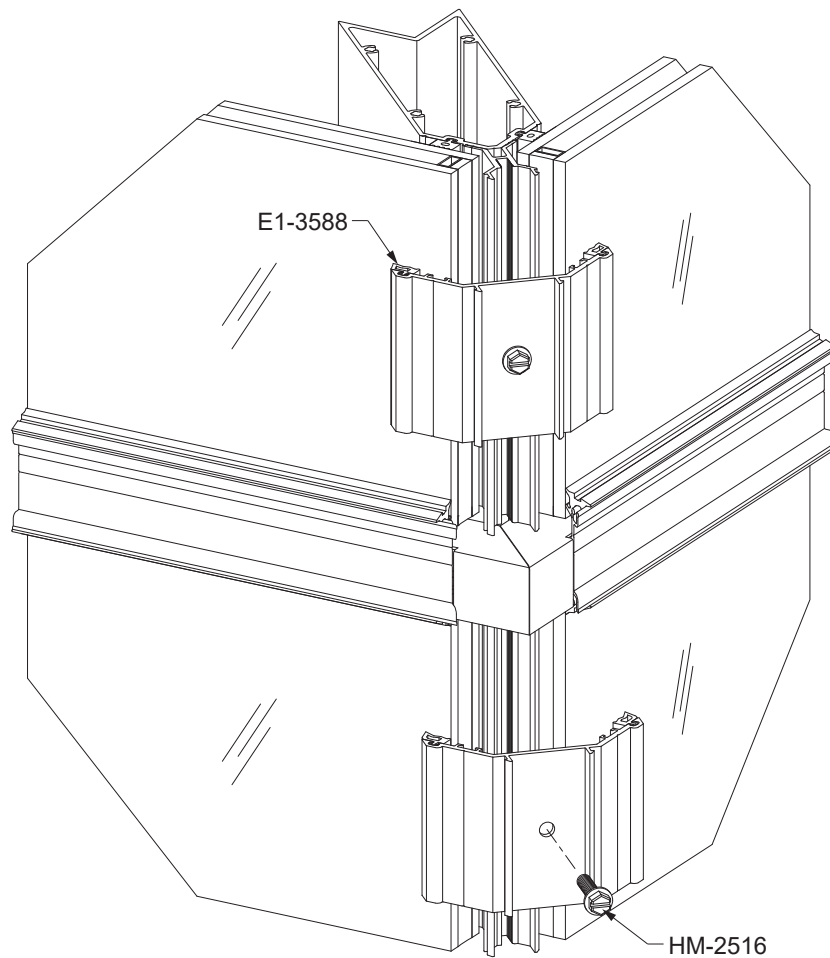
**DETAIL 10C**

CORNER INSTALLATION

STEP 6C

APPLY INTERIOR STRUCTURAL SILICONE SEALANT

- Carefully read and follow sealant manufacturers instructions.
- Make sure all silicone contact surfaces and joints have been cleaned with cleaner and method recommended by sealant manufacturer.
- Apply masking tape to the mullion and glass as shown in **Detail 11C**.
- Apply an approved structural silicone from the bottom to the top of the joint. Use positive pressure to completely fill the cavity between the glass and mullion.
- Using a nylon spatula or other non-scratching implement, tool the silicone immediately after running the mullion joint. Exert positive pressure while tooling to ensure that the silicone completely fills the cavity.
- Be careful not to remove too much silicone when tooling. The silicone should make complete contact with the glass and aluminum surfaces. The finished joint should be flush with the edge of the mullions and horizontals. See **Detail 11C**.
- Remove masking tape immediately after tooling before silicone skin forms.
- Allow silicone to cure as per manufacturer's recommendations. Temporary retainers should be left in place until silicone has fully cured. Contact structural silicone manufacturer for expected cure times.

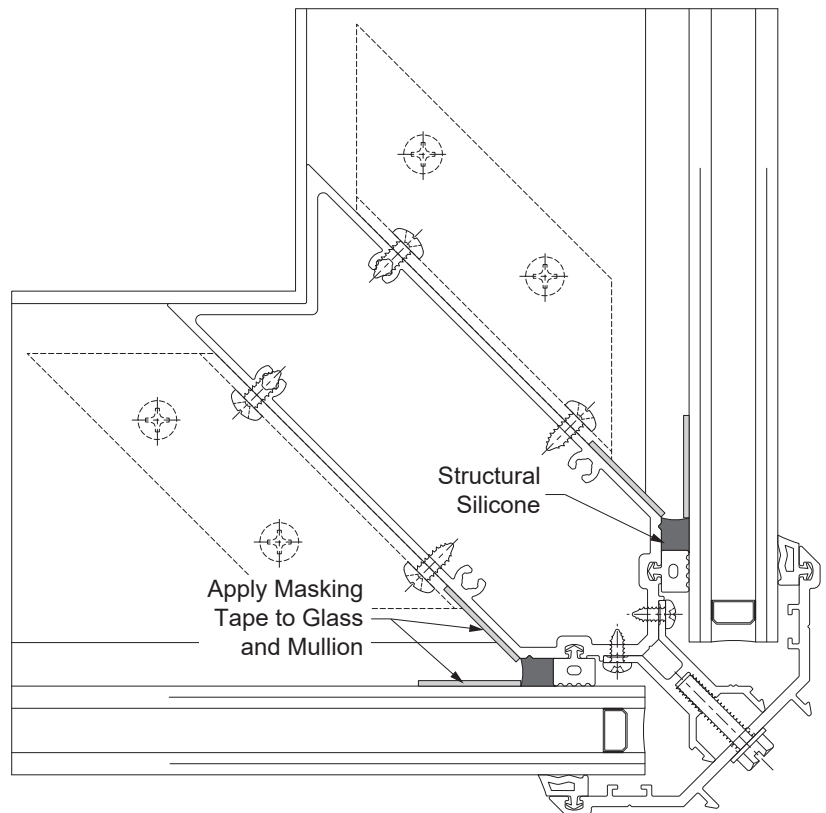

DETAIL 11C

CORNER INSTALLATION

**STEP 7C
APPLY FACE COVER SEAL
AT 90° OUTSIDE SSG CORNERS**

- Install exterior glazing gaskets and snap on face covers to the horizontal members at the SSG corner as previously shown in this manual.
- Refer to **Steps 26 to 28** for proper SSG glass lite installation.
- After glass is installed and exterior weatherseal is applied, apply a bead of sealant at the intermediate horizontal and sill along the top of the face cover gasket from weatherseal to weatherseal at the corner mullion.
- Tool the sealant to form a complete seal at the SSG corners.

See **Detail 12C**.

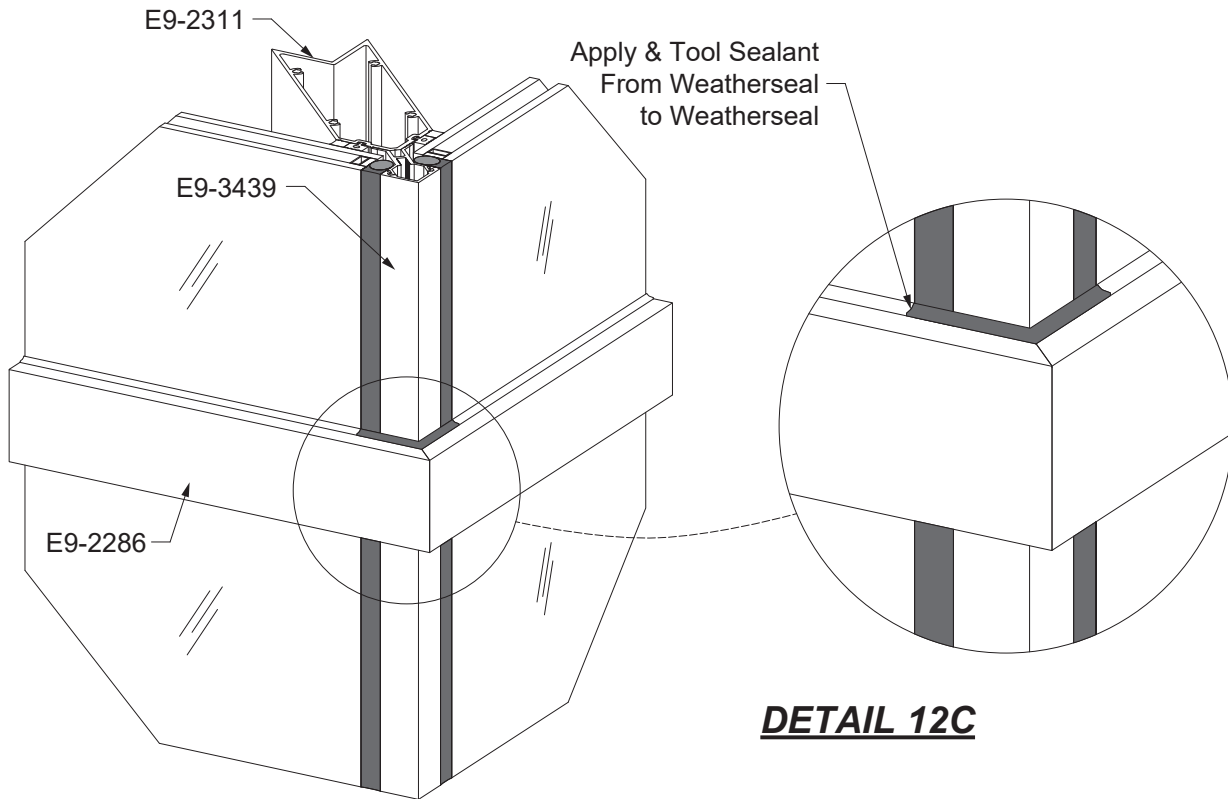

DOOR INSTALLATION

**STEP 1D
FABRICATE ONE PIECE VERTICAL
(FOR SIDE LITE APPLICATIONS)**

Door jambs are intended to run from the finished floor to the top of the frame head.
-Cut the frame members to Masonry Opening minus(-) 3/8.”

Note: Use E9-2304 at masonry jambs and E9-2306 or E9-2308 at side lites. **DO NOT USE TWO-PIECE MULLIONS FOR DOOR JAMBS.**

- Measuring from the top down, locate each horizontal location as shown on shop drawings. Ensure that the top of the intermediate horizontals and sill are marked.
- Measure down from the top of the jamb 5/16” and mark the centerline for the head shear block mounting holes.
- Measure down from the top of each intermediate horizontal and sill location 9/16” and mark the centerline for the shear blocks.
- Measure in from the back edge of the jamb 7/8” and mark the location for the rear fastener on the previously marked centerlines.
- Measure in from the back edge of the jamb 3-1/8” and mark the location for the front fastener on the same centerlines.
- Drill a 0.189” (#12) dia. hole at each location marked. See **Detail 1D**.

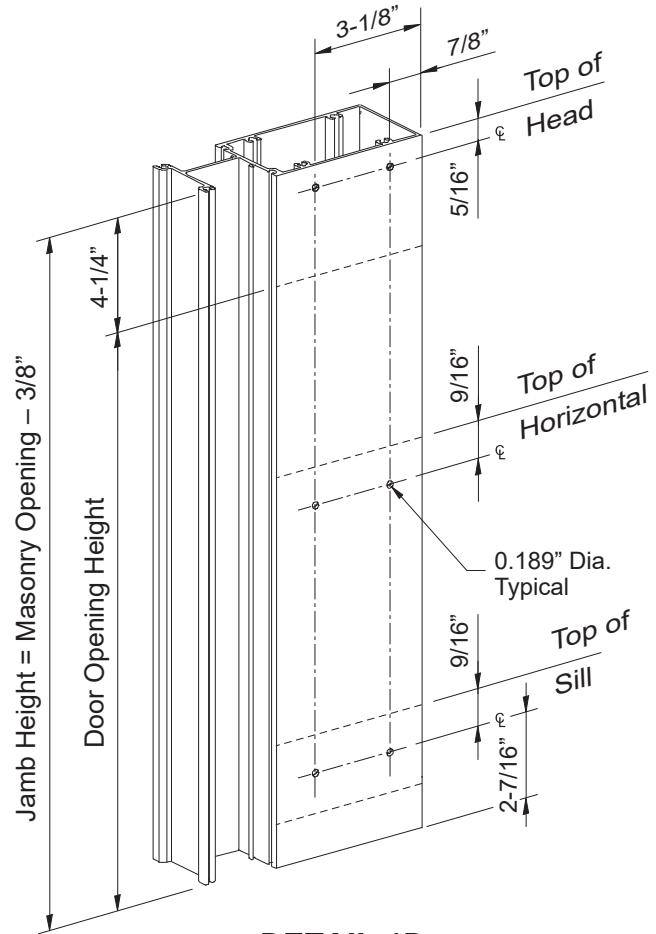

DETAIL 1D

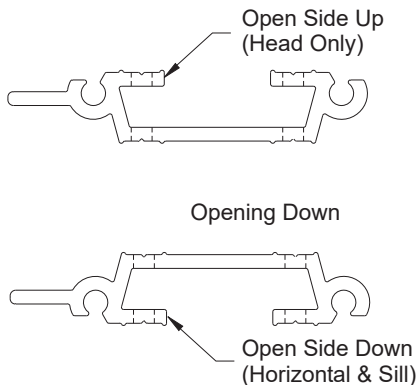

DETAIL 2D

**STEP 2D
ATTACH SHEAR BLOCKS**

Shear blocks are installed in one of two ways:
 Head shear block - Open portion of shear block UP.
 Horizontal/Sill shear block- Open portion of shear block DOWN.

See **Detail 2D**.

-Attach each shear block with two PC-1228 screws.

DOOR INSTALLATION

STEP 3D FABRICATE DOOR JAMBS WITHOUT TRANSOMS

- Measure from the top of each jamb down $1-11/16"$ and mark the centerline for the head shear block mounting holes.
- Measure in from the back edge of each jamb $7/8"$ and mark the location for the rear fastener on the previously marked centerline.
- Measure in from the back edge of each jamb $3-1/8"$ and mark the location for the front fastener on the same centerline.
- Drill a $0.189"$ (#12) dia. hole at each hole location.
- Attach a shear block to each door jamb with (2) PC-1228 fasteners.

See **Detail 3D**.

DETAIL 3D

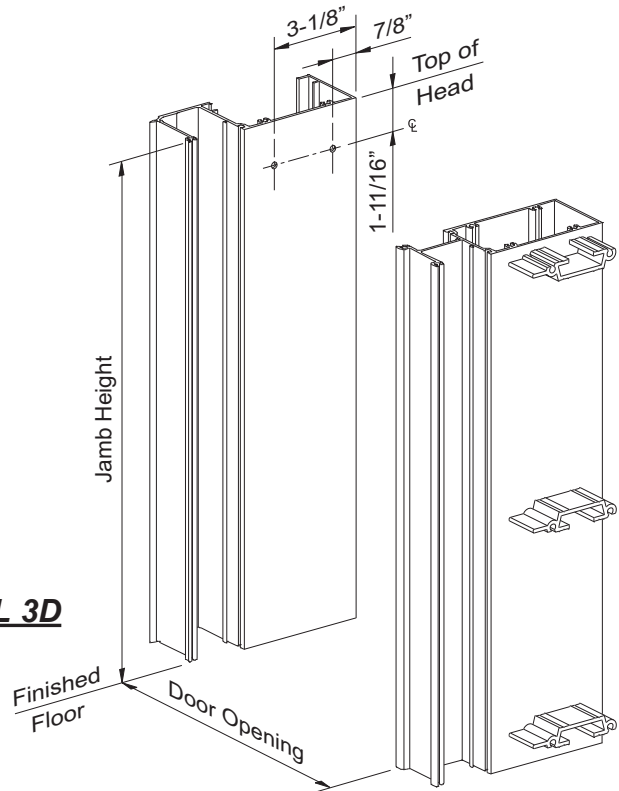

FABRICATE DOOR JAMBS WITH TRANSOMS

- Measure from the top of each jamb down $5/16"$ and mark the centerline for the head shear block mounting holes.
- Measure from the bottom of each jamb up the door opening height plus (+) $4-1/4"$ to mark the top of the horizontal, above the door header.
- Measure down $9/16"$ from the previous mark to locate the centerline of the shear block.
- Measure in from the back edge of each jamb $7/8"$ and mark the location for the rear fastener on the previously marked centerline.
- Measure in from the back edge of each jamb $3-1/8"$ and mark the location for the front fastener on the same centerline.
- Drill a $0.189"$ (#12) dia. hole at each hole location.
- Attach a shear block to each door jamb with (2) PC-1228 fasteners.

See **Detail 4D**.

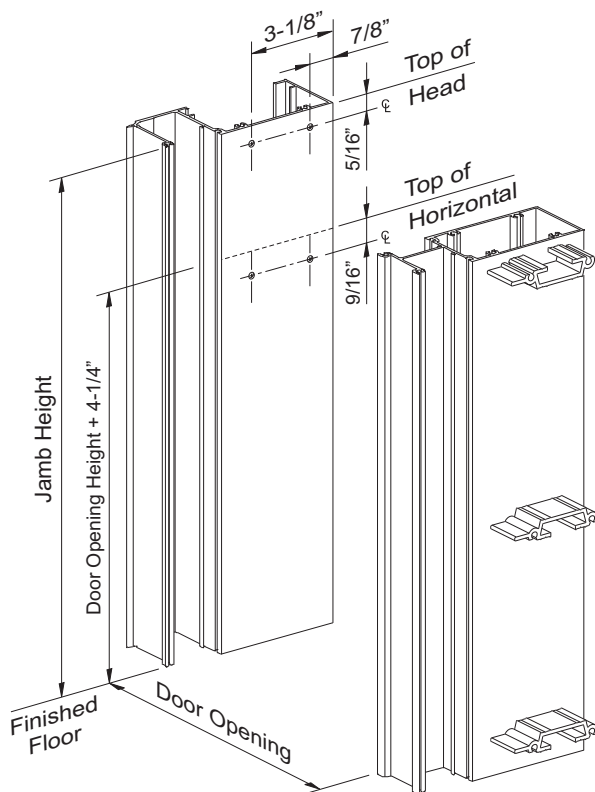

DETAIL 4D

DOOR INSTALLATION

STEP 4D
FABRICATE DOOR FRAME SIDE LITE MEMBERS

Horizontal members that will be attached to the door jambs require additional fabrication to attach to the shear blocks. For jamb side follow the instructions below; for intermediate vertical side follow appropriate frame fabrication in **Steps 3 & 4**.

Head and Intermediate Horizontal:

- Measure in 1" from the door jamb end of the horizontal member and mark the hole locations on each of the interior set of "V"-grooves.
 - Drill a 0.236" diameter (#B drill bit) hole at each location marked.
- See **Detail 5D**.

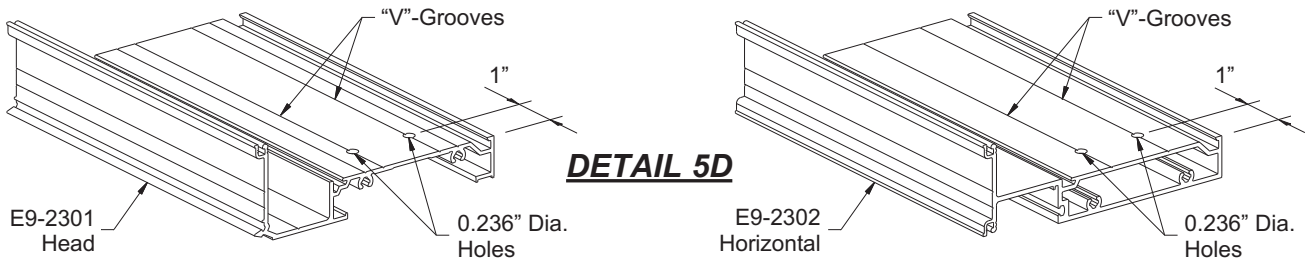

Sill, Door Head, and Transom Horizontal:

- Measure in 1" from the door jamb end of the horizontal member and mark the centerline for the shear block fastener hole locations.
 - Measure in from the back edge of the horizontal member 1-5/16" and mark a hole location along the centerline.
 - Mark a second hole location along the centerline 2-11/16" from the back edge of the horizontal.
 - Drill a 0.236" diameter (#B drill bit) hole at each location marked and countersink for a #12 fastener.
- See **Detail 6D**.

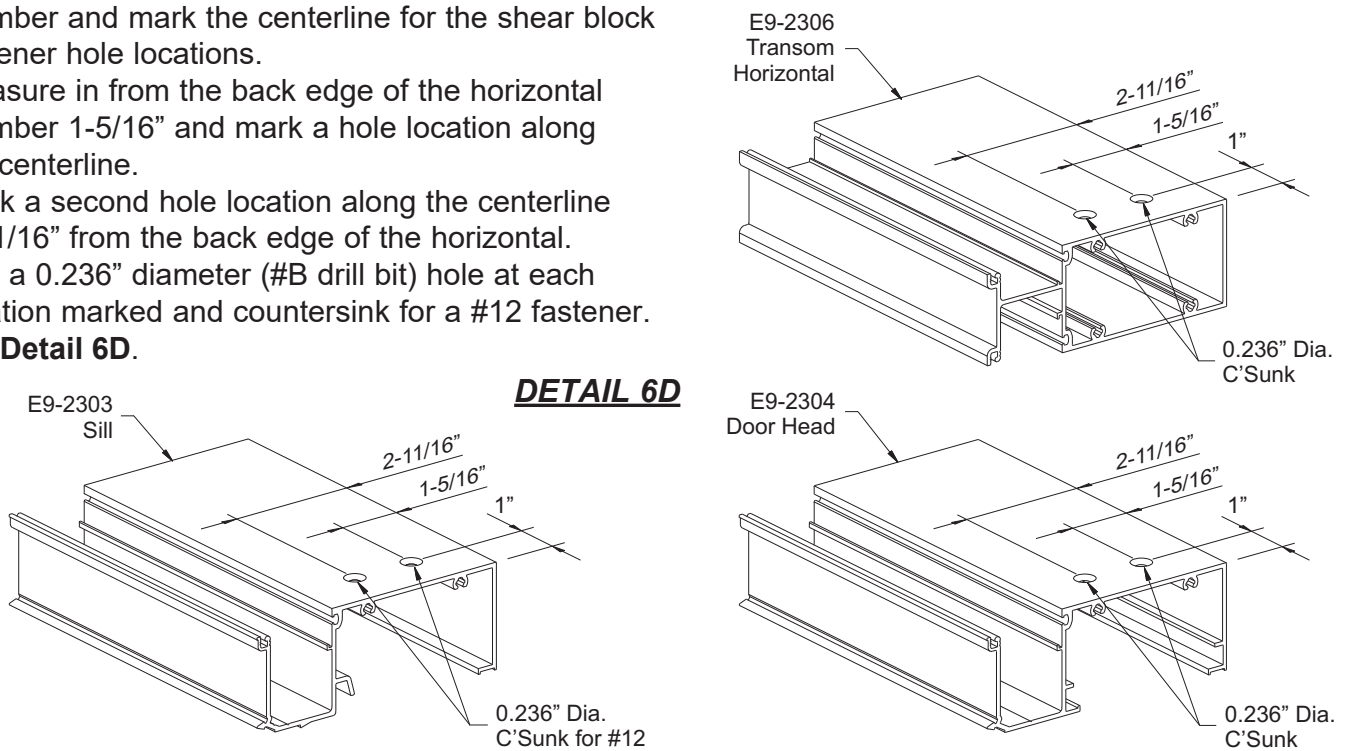

DOOR INSTALLATION

**STEP 5D
INSTALL DOOR JAMBS & SIDE LITES**

-Bring the door jamb into position, butted against the sill flashing.

Prior to attaching the side lites, the end of the sill flashing must be sealed to the door jamb.

- Apply and tool sealant to all sill flashing to door jamb joints.
- Apply a liberal amount of sealant to completely fill the glazing pocket and ramp the sealant down onto the sill flashing.

See **Detail 7D**.

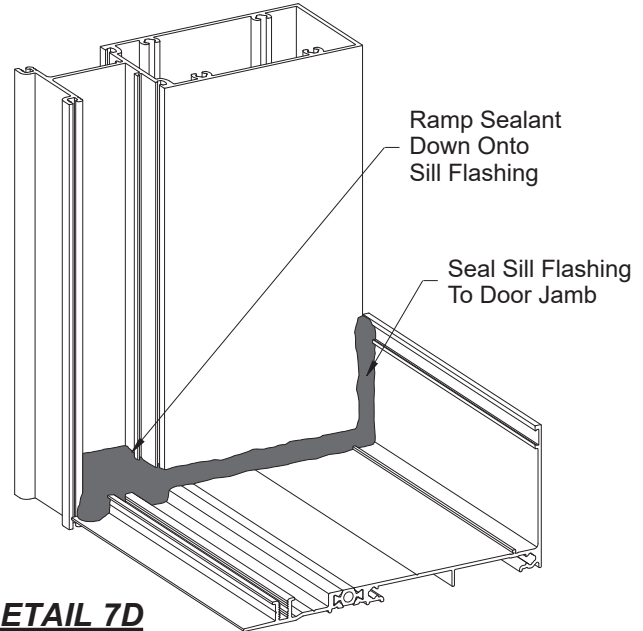

DETAIL 7D

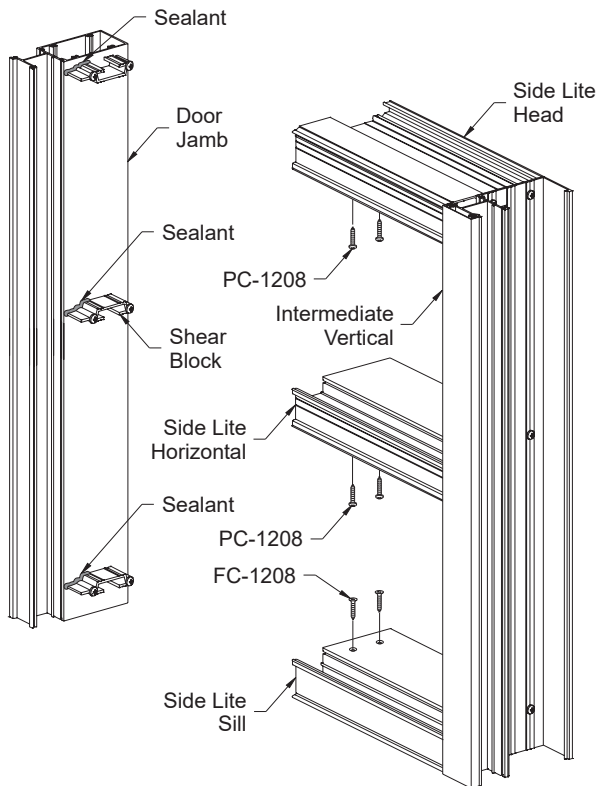

DETAIL 8D

- Attach the side lite members to the intermediate vertical as previously shown in **Step 11**.
- Prior to attaching the horizontal members to the door jambs, apply sealant to the front top portion of the shear blocks and to the ends of the horizontal members as shown in **Step 11**.
- Attach the head and intermediate horizontal to the shear blocks with (2) PC-1208 fasteners and attach the sill with (2) FC-1208 fasteners.
- Seal all joints and install water deflectors at all intermediate horizontals as shown in **Steps 20 & 21**.

Note: Side lite members must be shear blocked to door jambs regardless of frame type. All jambs must be installed square and plumb.

See **Detail 8D**.

DOOR INSTALLATION

STEP 6D
INSTALL DOOR SUB-FRAME

Doors are shipped assembled, and door sub-frames will be fabricated and shipped knocked down. Please refer to the Entrances Installation Manual for door installation and follow the instructions below to install the door sub-frame.

- Cut pocket filler, E9-2345, to the Door Opening Height minus(-) 1/16" for each jamb.
 - Cut pocket filler, E9-2345, to the Door Opening Width minus(-) 1/32" for the horizontal above the door frame.
 - Install isolator clips, E3-0037, 3" from each end and 12" on center for E9-2304 or E2-0511 glazing gasket for E9-2306.
 - Apply sealant into the interior gasket reglets and rotate the pocket filler into place.
 - Install face covers, E9-2286, by engaging them with the isolator clips or gasket and rotating them over to snap onto the pocket fillers.
- See **Detail 9D**.

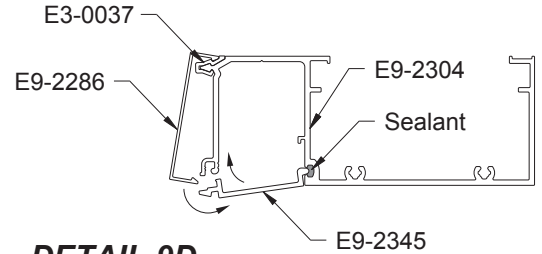

DETAIL 9D

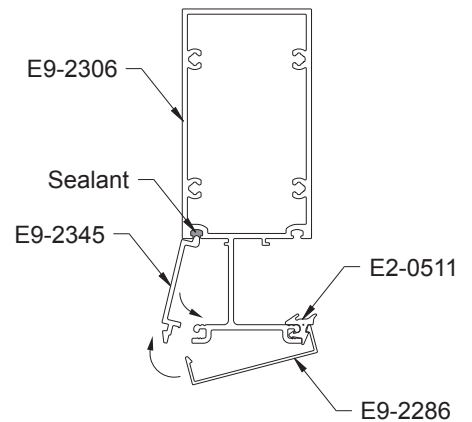

- Position the door sub-frame into place.
 - Fasten the jamb, E9-2344, to the vertical using PC-1216 fasteners, 3" from each end and 12" on center. Fasten the transom bar, AS-0402, to the horizontal using FC-1236 fasteners, 3" from each end and 12" on center. Shim between the sub-frame and YWE 60 T frame as needed.
 - Install door stop, AS-0417, into the door jambs.
 - Apply and tool sealant between the sub-frame and YWE 60 T frame on the interior and exterior.
- See **Detail 10D**.

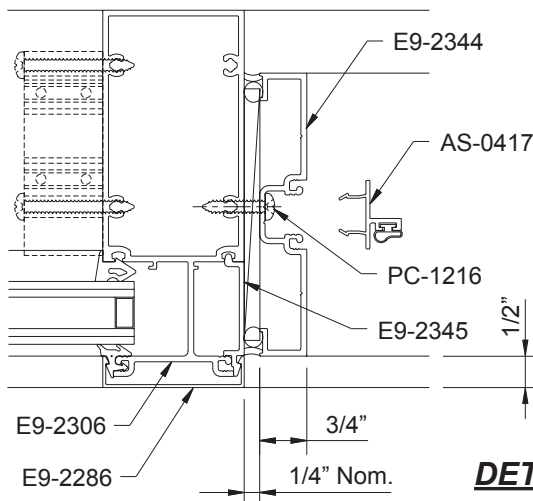

DETAIL 10D

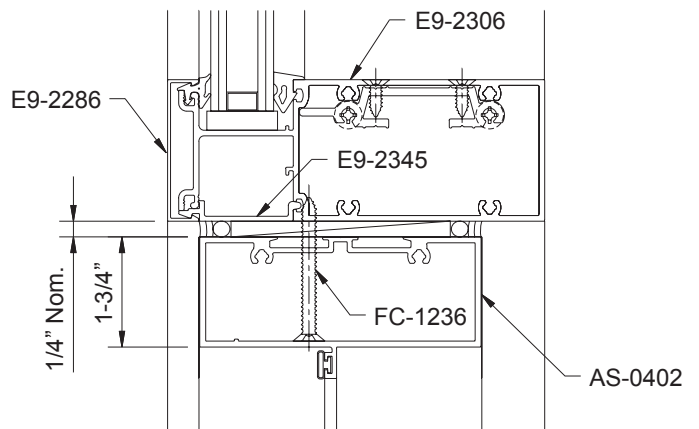



101 Marietta Street NW
Suite 2700
Atlanta, Georgia 30303
www.ykkap.com