

# YES 40 FS/FI Storefront System

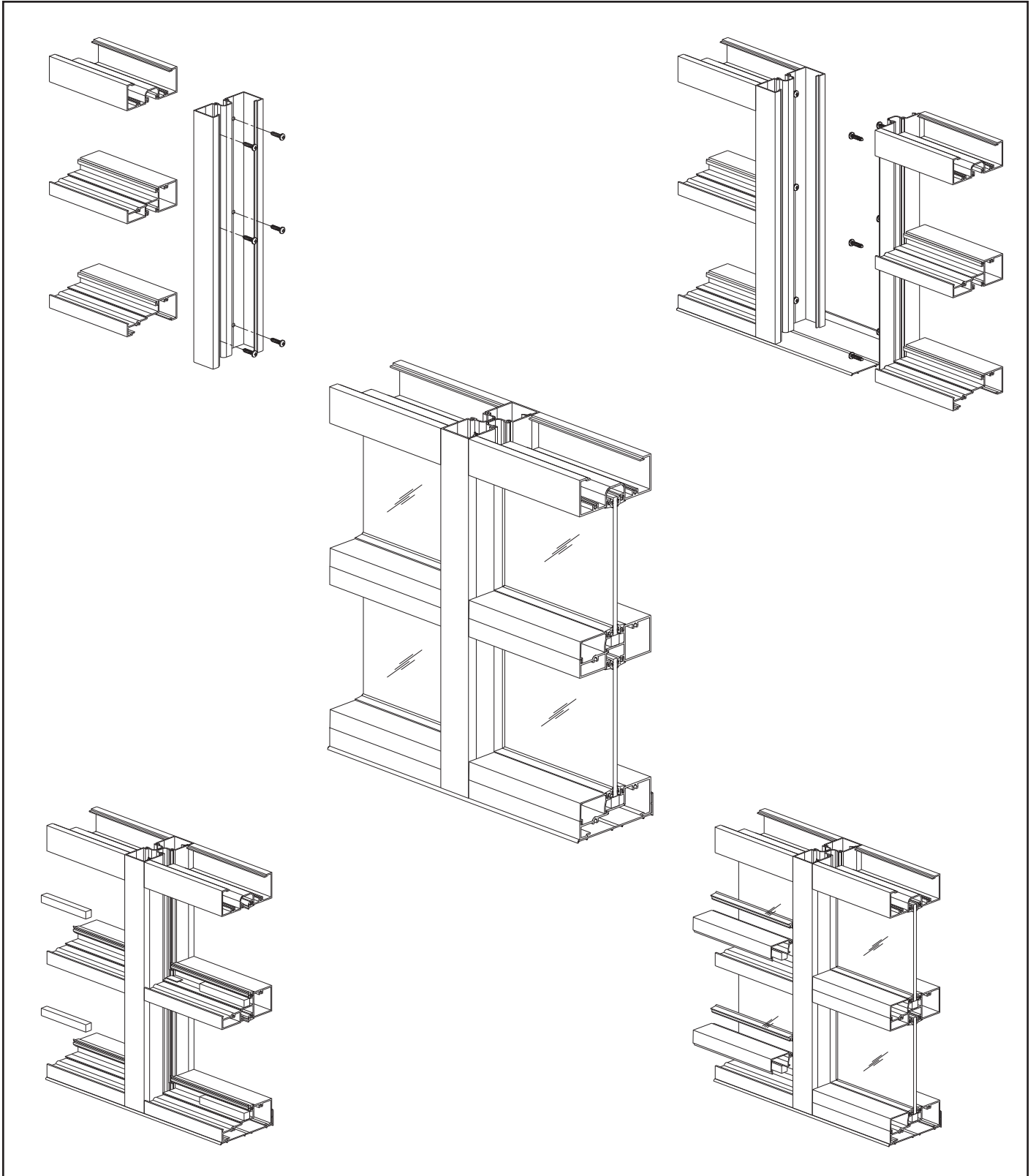

## Installation Manual















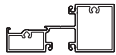

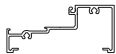
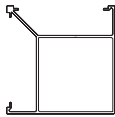

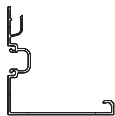

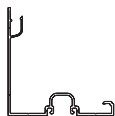

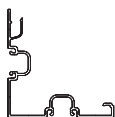
## TABLE OF CONTENTS

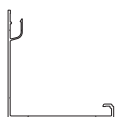
Installation Notes .....	Page ii
<b>PARTS DESCRIPTION</b>	
YES 40 FS Framing Members .....	Page 1
YES 40 FI Framing Members.....	Page 2
YES 40 FS/FI Door Framing Members .....	Page 3
YES 40 FS/FI Accessories .....	Pages 4 & 5
YES 40 FS/FI Fasteners .....	Page 5
<b>FRAME FABRICATION</b>	
Determine Frame Size.....	Pages 6 & 7
Fabricate Sill Flashing .....	Page 8
Fabricate Head Receptor .....	Page 9
Fabricate Two Piece Verticals for Screw Spline Assembly.....	Page 10
Fabricate Tubular Verticals for Shear Block Assembly .....	Page 11
Fabricate Head, Horizontal & Sill Members .....	Page 12
Fabricate Glass Stops & Glazing Adaptors.....	Page 12
<b>FRAME ASSEMBLY</b>	
Assemble Frames For Screw Spline Assembly .....	Page 13
Assemble Frames For Shear Block Assembly.....	Page 14
Install Foam Plugs at Head .....	Page 15
<b>FRAME INSTALLATION</b>	
Install Sill Flashing.....	Pages 16 & 17
Attach Head Receptor End Caps .....	Page 18
Install Head Receptor .....	Page 19
Install Frames .....	Pages 20 to 22
Apply Perimeter Sealant.....	Page 23
Install Water Deflectors .....	Page 24
Apply Internal Sealant .....	Page 25
Install Glazing Adaptors.....	Page 25
<b>GLAZING</b>	
Install Interior Glazing Gaskets .....	Page 26
Install Glass .....	Page 27
Install Anti-Walk Blocks .....	Page 28
Install Exterior Glass Stops & Gaskets .....	Page 28

## Installation Notes

1. Do not drop, roll or drag boxes of aluminum framing. Move and stack boxes with proper support to prevent distortion. If fork lifts are used be especially careful about striking the boxes when lifting or moving.
2. Store in a dry, out of the way area. If rain exposure, condensation or any water contact is likely, then all packaging material should be removed. Wet packaging materials will discolor and may stain aluminum finishes and paints.
3. All materials should be checked for quality and quantity upon receipt, YKK AP must be notified immediately of any discrepancies in shipment. Check to make sure that you have the required shims, sealants, supplies and tools necessary for the installation.
4. Carefully check the openings and surrounding conditions that will receive your material. Remember, if the construction is not per the construction documents, it is your responsibility to notify the general contractor in writing. Any discrepancies must be brought to the general contractor's attention before you proceed with the installation.
5. Gather your shop drawings, materials, packing list, and this installation manual. Carefully review parts location, the sequence it goes therein, when you glaze it and how you seal it. Installation instructions are of a general nature and may not cover every condition you will encounter. The shop drawings and/or installation manuals were prepared specifically for the product.
6. Any material substitutions must be of equal or greater quality.
7. Make certain that material samples have been sent for compatibility testing for all manufacturer's sealants involved. Make certain sealants have been installed in strict accordance with the manufacturer's recommendations and specifications.
8. Remember to isolate, in an approved manner, all aluminum from uncured masonry or other incompatible materials.
9. System-to-structure fasteners are not supplied by YKK AP. Fasteners called out on shop drawings are to indicate minimum sizes for design loading.
10. Entrances are to be installed plumb, square, level and true.
11. If any questions arise concerning YKK AP products or their installation, contact YKK AP for clarification before proceeding.
12. YKK AP storefront and/or curtain wall framing is typically completed before drywall, flooring and other products which may still be in process. Take the extra time to wrap and protect the work produced.
13. Cutting tolerances are plus zero (0"), minus one thirty second (-1/32") unless otherwise noted.
14. Check our website, [www.ykkap.com](http://www.ykkap.com), for the latest installation manual update prior to commencing work.











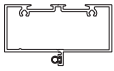

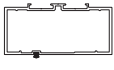
FRAMING MEMBERS (1-3/4" x 4")

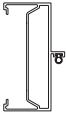
	<b>Head/Jamb/Vertical</b>	<b>E9-1303</b>		<b>Head Receptor</b> Elastomer Weathering E2-0051 Not Included	<b>E9-1310</b>
	<b>Horizontal</b>	<b>E9-1306</b>		<b>Head Receptor Stop</b> Elastomer Weathering E2-0051 Not Included	<b>E9-1033</b>
	<b>Sill/Horizontal</b>	<b>E9-1304</b>		<b>Two Way 90° Corner Post</b>	<b>E9-1309</b>
	<b>Glass Stop</b>	<b>E9-1305</b>		<b>Two Piece 90° Corner Post</b>	<b>E9-1321</b>
	<b>Sill Flashing</b>	<b>E9-1030</b>		<b>Two Piece 90° Corner Post</b>	<b>E9-1322</b>
	<b>Jamb/Vertical</b>	<b>E9-1301</b>		<b>Two Piece 90° Corner Post</b>	<b>E9-1323</b>
	<b>Deep Pocket Filler</b>	<b>E9-1009</b>		<b>Two Piece 90° Corner Post</b>	<b>E9-1324</b>
	<b>Shallow Pocket Filler</b>	<b>E9-1002</b>		<b>Sidelite Base</b>	<b>E9-1034</b>
	<b>Expansion Mullion (Female)</b> Weathering Gasket K2-2441 Not Included	<b>E9-1325</b>		<b>Sidelite Base Shoe</b>	<b>E9-1035</b>
	<b>Expansion Mullion (Male)</b> Use with E9-1325	<b>E9-1326</b>		<b>Sidelite Base Glass Stop</b>	<b>E9-0403</b>
	<b>Flush Pocket Filler</b>	<b>E9-1010</b>		<b>Flat Filler</b>	<b>E9-1038</b>

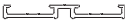
## FRAMING MEMBERS (2" x 4")

	<b>Head/Jamb/Vertical</b>	<b>E9-1313</b>		<b>Glazing Adaptor</b> For 5/8" & 3/4" Glazing	<b>E9-1039</b>
	<b>Horizontal</b>	<b>E9-1316</b>		<b>Glazing Adaptor</b> For 3/16", 1/4", 5/16", & 3/8" Glazing	<b>E9-1040</b>
	<b>Sill/Horizontal</b>	<b>E9-1314</b>		<b>Two Way 90° Corner Post</b> Use with E9-1019	<b>E9-1309</b>
	<b>Glass Stop</b>	<b>E9-1315</b>		<b>Deep Pocket Filler</b> Use with E9-1309 Corner Mullion	<b>E9-1019</b>
	<b>Sill Flashing</b>	<b>E9-1030</b>		<b>Sidelite Base</b>	<b>E9-1034</b>
	<b>Shallow Pocket Filler</b>	<b>E9-1012</b>		<b>Sidelite Base Shoe</b>	<b>E9-1035</b>
	<b>Flush Pocket Filler</b>	<b>E9-1020</b>		<b>Sidelite Base Glass Stop</b>	<b>E9-0413</b>
	<b>Head Receptor</b> Elastomer Weathering E2-0051 Not Included	<b>E9-1310</b>		<b>Flat Filler</b>	<b>E9-1038</b>
	<b>Head Receptor Stop</b> Elastomer Weathering E2-0051 Not Included	<b>E9-1033</b>			

**Door Framing Members**

 <p><b>Single Acting Transom Bar</b> Elastomer Weathering E2-0051 Included</p>	<p><b>AS-0452</b></p>	 <p><b>Door Stop O/P Assembly</b> Elastomer Weathering E2-0051 Included</p>	<p><b>AS-0409</b></p>
 <p><b>Double Acting Transom Bar</b> Pile Weathering E2-0062 Included</p>	<p><b>AS-0456</b></p>	 <p><b>Door Stop Base</b> Use with AS-0409</p>	<p><b>E9-1113</b></p>
 <p><b>Single Acting Door Jamb</b> Elastomer Weathering E2-0051 Included</p>	<p><b>AS-0451</b></p>	 <p><b>Door Stop Assembly</b> Elastomer Weathering E2-0051 Included</p>	<p><b>AS-0457</b></p>
 <p><b>Double Acting Door Jamb</b></p>	<p><b>E9-0453</b></p>	 <p><b>Sash Base</b> Use with E9-0403 or E9-0413 Glass Stops</p>	<p><b>E9-0408</b></p>
 <p><b>Intermediate Door Jamb</b></p>	<p><b>E9-9311</b></p>	 <p><b>Threshold</b> 1/2" x 4"</p>	<p><b>E9-0407</b></p>
 <p><b>Transom Glass Stop</b> For 1/4" Glazing</p>	<p><b>E9-0403</b></p>		
 <p><b>Transom Glass Stop</b> For 1" Glazing</p>	<p><b>E9-0413</b></p>		
 <p><b>Transom Glazing Pocket</b> For 1/4" Glazing</p>	<p><b>E9-0434</b></p>		
 <p><b>Transom Glazing Pocket</b> For 1" Glazing</p>	<p><b>E9-0435</b></p>		

## ACCESSORIES

	<b>Shear Block</b> For Head, Horizontal & Sill (YES 40 FS)	<b>E1-1012</b>		<b>Setting Block</b> For 1/4" Glazing (YES 40 FS)	<b>E2-0019</b>
	<b>Shear Block</b> For Head, Horizontal & Sill (YES 40 FI)	<b>E1-1013</b>		<b>Setting Block</b> For 1" Glazing (YES 40 FI)	<b>E2-0020</b>
	<b>Shear Block</b> For Transom Bar AS-0456	<b>E1-0326</b>		<b>Setting Block</b> For Transom Bar 1" Glazing (YES 40 FI)	<b>E2-0056</b>
	<b>Shear Block</b> For Sidelite Base (YES 40 FS)	<b>E1-1010</b>		<b>Water Deflector</b> For 1" Glazing (YES 40 FI)	<b>E2-0047</b>
	<b>Shear Block</b> For Sidelite Base (YES 40 FI)	<b>E1-1011</b>		<b>Water Deflector</b> For 1/4" Glazing (YES 40 FS)	<b>E2-0048</b>
	<b>End Dam</b> For Sill Flashing E9-1030	<b>E1-1147</b>		<b>Anti-Walk Block</b> For Deep Pocket (YES 40 FI)	<b>E2-0153</b>
	<b>End Cap</b> For Head Receptor E9-1310	<b>E1-0178</b>		<b>Glazing Gasket</b>	<b>E2-0052</b>
	<b>Splice Sleeve</b> For Sill Flashing E9-1030	<b>E1-1146</b>		<b>Glazing Gasket</b>	<b>E2-0053</b>
	<b>Silicone Splice Sheet</b> For Head Receptor Splice	<b>E2-0070</b>		<b>Glazing Gasket</b>	<b>E2-0064</b>
	<b>Flat Filler</b> Use at all Anchor Locations	<b>E1-1054</b>		<b>Elastomer Weathering</b>	<b>E2-0051</b>
	<b>Steel Reinforcing</b> (YES 40 FS)	<b>E1-0157</b>		<b>Pile Weathering</b>	<b>E2-0062</b>
	<b>Steel Reinforcing</b> (YES 40 FI)	<b>E1-0166</b>		<b>Weathering Gasket</b> Use with Expansion Mullion E9-1325	<b>K2-2441</b>



ACCESSORIES (Continued)

	<b>Foam Backer Tape</b> 1" x 1-1/4" (Roll)	E2-0259	E2-0259
--	---	---------	---------

FASTENERS

	<b>#8 x 1/4" FHMS</b> Zinc Plated Steel, For Attachment of Steel Reinforcing to Vertical (YES 40 FI)	FM-0804		<b>#12 x 1" PHSMS</b> Type AB, Zinc Plated Steel For Screw Spline Attachment	PC-1216
	<b>#8 x 3/8" FHMS</b> Zinc Plated Steel, For Attachment of Steel Reinforcing to Vertical (YES 40 FS)	FM-0806		<b>#12 x 1-1/4" PHSMS</b> Type AB, Zinc Plated Steel For Screw Spline Attachment	PC-1220
	<b>#10 x 1/2" FHSMS</b> Type AB, Zinc Plated Steel, For Attach. of Horiz. to Shear Blocks E1-0326, E1-1010, E1-1011	FC-1008		<b>#12 x 1-3/4" PHSMS</b> Type AB, Zinc Plated Steel For Attachment of Shear Block E1-0326 to Vertical	PC-1228
	<b>#12 x 1/2" FHSMS</b> Type AB, For Attachment of Head to Shear Blocks E1-1012 & E1-1013 and Receptor End Cap E1-0178	FC-1208		<b>#12 x 3" PHSMS</b> Type AB, Zinc Plt. Stl., For Attach. of Shear Block E1-1010 & E1-1011 to Vertical	PC-1248
	<b>#10 x 1-3/4" PHSMS</b> Type AB, Zinc Plated Steel, For Attachment of Shear Blocks E1-1012 & E1-1013 to Vertical	PC-1028		<b>#12 x 3/4" UFHMSMS Type A</b> , Zinc Plated Steel For End Cap Attachment	UA-1212
	<b>#12 x 5/8" PHSMS</b> Type AB, Zinc Plated Steel For Attach. of Horizontal & Sill to Shear Block E1-1013	PC-1210			

## FRAME FABRICATION

### STEP 1 DETERMINE FRAME SIZE

#### Determine Frame Width:

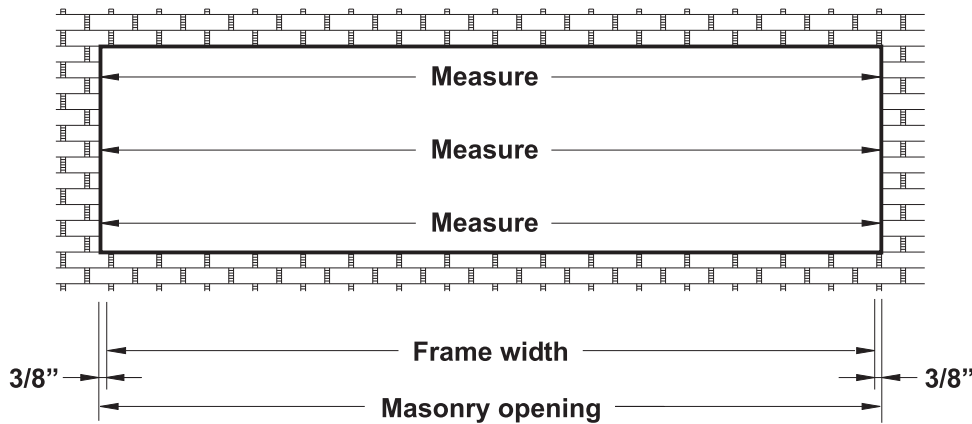

**Note:** Check the opening for squareness and plumb at both ends. Units must be installed in a true rectangle.

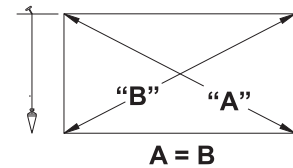

**Detail 1**

- Measure the width of the masonry opening at the top, middle and bottom.
  - Select the smallest dimension measured and subtract 3/4" to the determine the frame width to be used.
- See **Detail 1**.

**NOTE:** Frame widths over 24'-0" require expansion mullions every 12 to 15 feet (best location at vertical next to the door jamb.)

#### Determine Frame Height:

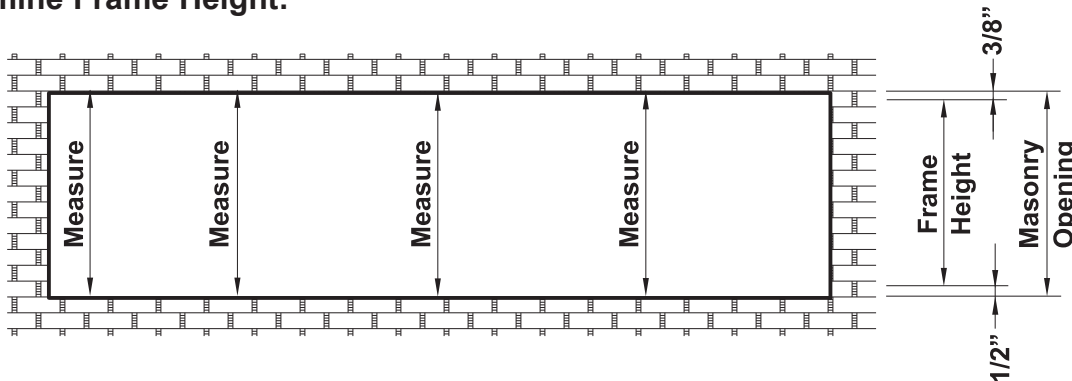

**Detail 2**

- Measure the height of the masonry opening in several places along the entire length of the opening.
- Select the smallest dimension measured and subtract 7/8" to determine the frame height to be used:
  - 3/8" shim/caulk joint at the head.
  - 1/8" for sill flashing, E9-1030.
  - 3/8" shim/caulk joint below the sill flashing.

See **Detail 2**.

## FRAME FABRICATION

### STEP 1

#### DETERMINE FRAME SIZE

Determine Frame Height for Receptor Conditions:

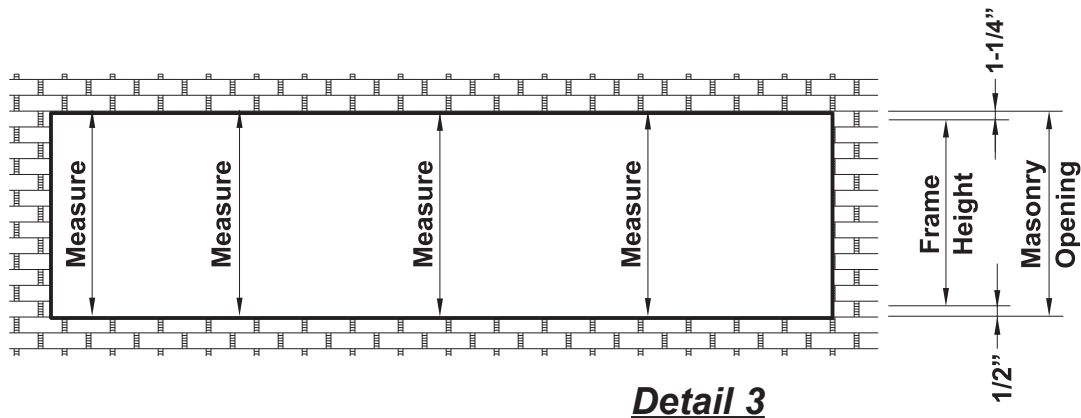

-Measure the height of the masonry opening in several places along the entire length of the opening.

-Select the smallest dimension measured and subtract 1-3/4" to determine the frame height to be used:

Minimum 3/8" shim/caulk joint at the head.

7/8" for the head receptor

1/8" for sill flashing.

Minimum 3/8" shim/caulk joint below the sill flashing.

See **Details 3 & 4**.

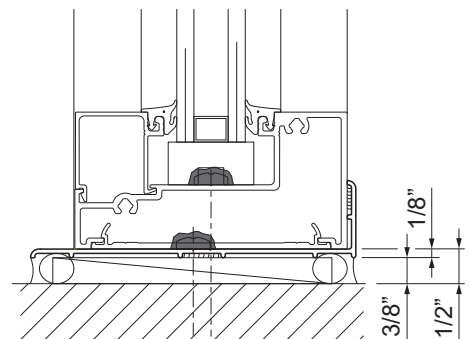
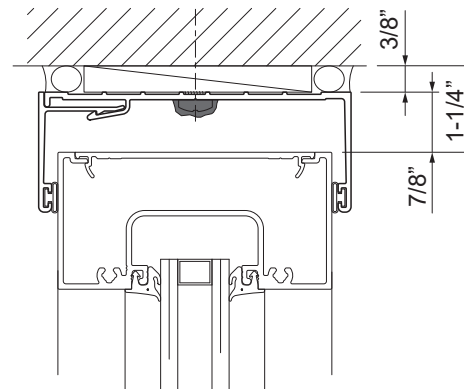

**Detail 4**

**FRAME FABRICATION**

**STEP 2  
FABRICATE SILL FLASHING**

**For elevations without door framing:**

-Cut sill flashing, E9-1030, to the frame width determined in **Step 1** plus(+) 1/8" at each jamb.

**For elevations with door framing:**

-Cut the sill flashing, E9-1030, from the end of the frame plus(+) 1/8" to the door jamb.  
(See approved shop drawings for this dimension)

See **Detail 5**.

-For openings longer than 24'-0", allow for a 3/8" joint for expansion between sill flashing members.

**Detail 5**

YES 40 FS Shown  
YES 40 FI Similar

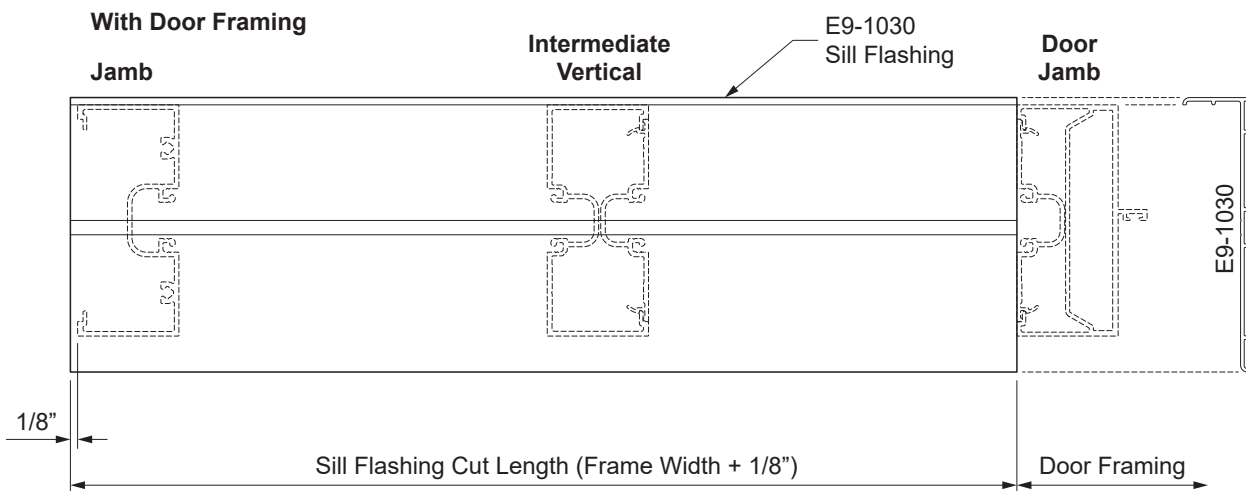
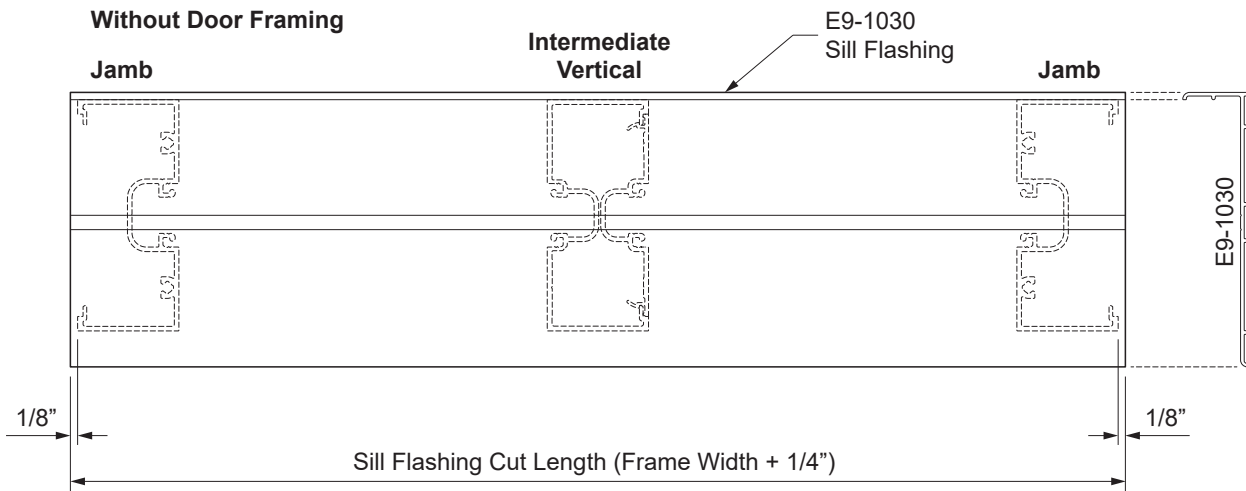

## STEP 2A FABRICATE HEAD RECEPTOR

- Cut the head receptor E9-1310 and the E9-1033 snap cover to the frame width plus (+) 1/8" at each jamb or as indicated on the approved shop drawings.
- At each jamb, drill two Ø0.189" tap holes in to the E9-1310 head receptor as shown.
- For openings longer than 24'-0" the head receptor needs to be spliced every twelve to fifteen feet at the center of a D.L.O.
- Allow for a 3/8" joint for expansion between head receptor members.

See **Detail 6**.

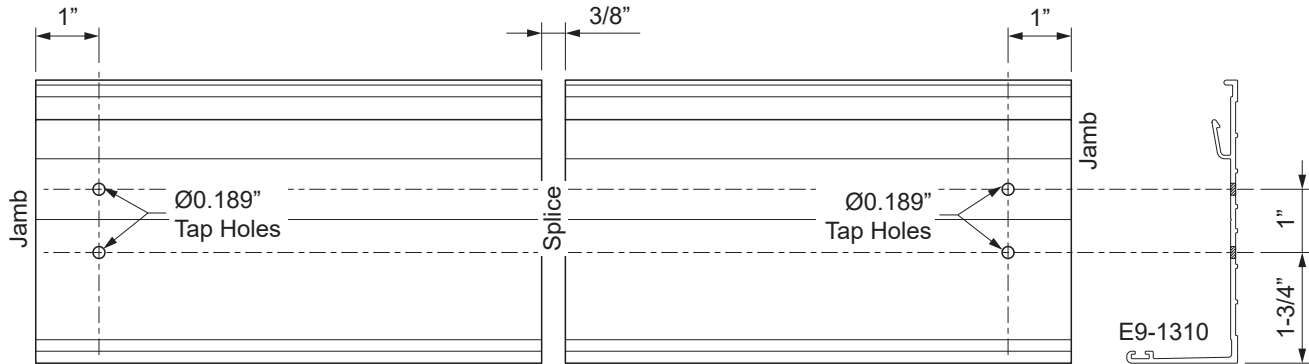

**Detail 6**

## FRAME FABRICATION

### STEP 3 FABRICATE TWO PIECE VERTICALS FOR SCREW SPLINE ASSEMBLY

-Cut the two piece vertical and jamb members to the frame height determined in Step 1.  
-Fabricate holes in vertical members for screw spline attachment using one of the methods below:

1. Using a short piece of each horizontal member as a template, center the template on the face of the vertical and mark the location of each screw spline.  
Drill a 0.236" diameter (#B drill bit) hole at each location marked.
2. Layout the hole locations as shown in **Detail 7** and drill a 0.236" dia. (#B drill bit) clearance hole at each location marked.
3. Use the YKK AP drill fixture, H-7201, to drill the holes.
4. Use punch press with appropriate die set.

See **Detail 7**.

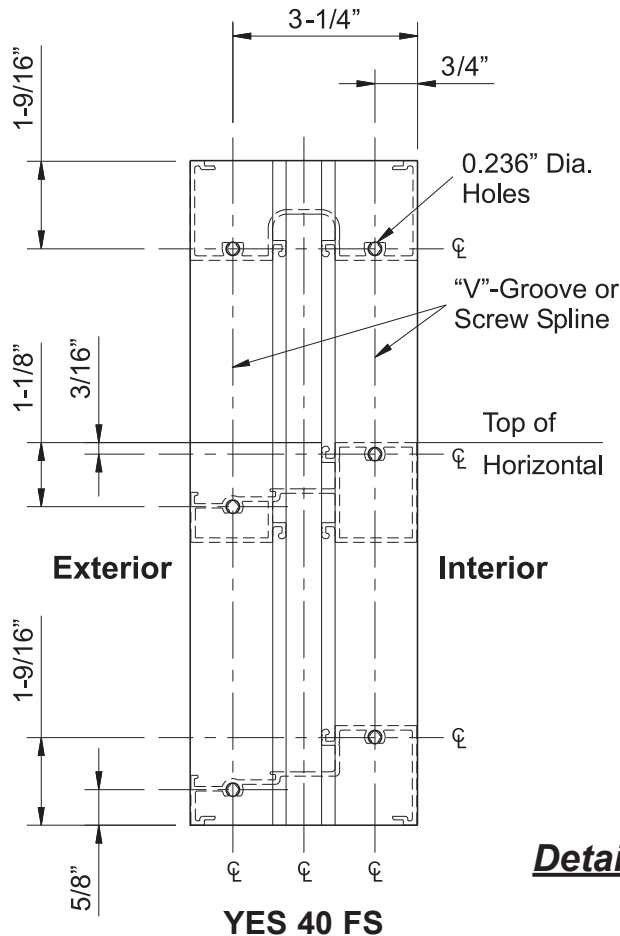

**Detail 7**

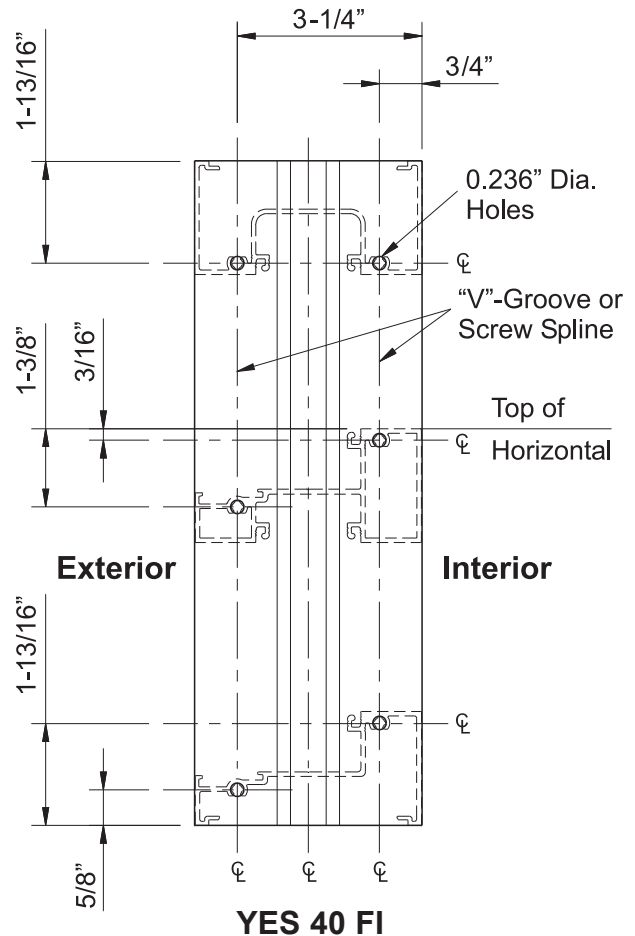

## FRAME FABRICATION

### STEP 4

### FABRICATE TUBULAR VERTICALS FOR SHEAR BLOCK ASSEMBLY

#### YES 40 FS & YES 40 FI:

- Cut the vertical and jamb members to the frame height determined in **Step 1**.
- Tubular verticals require shear blocks for the attachment of head, horizontal and sill members:
  - E1-1012 for YES 40 FS.
  - E1-1013 for YES 40 FI.

**Note:** Open back horizontals, E9-1304 (YES 40 FS) and E9-1314 (YES 40 FI), must be used when using shear blocks.

- Mark the location for each shear block using one of the methods below:
  1. Use a short piece of each horizontal member with a shear block installed as a template. Center the template on the face of the vertical and mark each hole location.
  2. Layout the shear blocks as shown in **Detail 8**.

- Drill a 0.161" diameter hole (#20 drill bit) at each location marked.
- Attach the shear blocks to the verticals using three (3) PC-1028 fasteners.

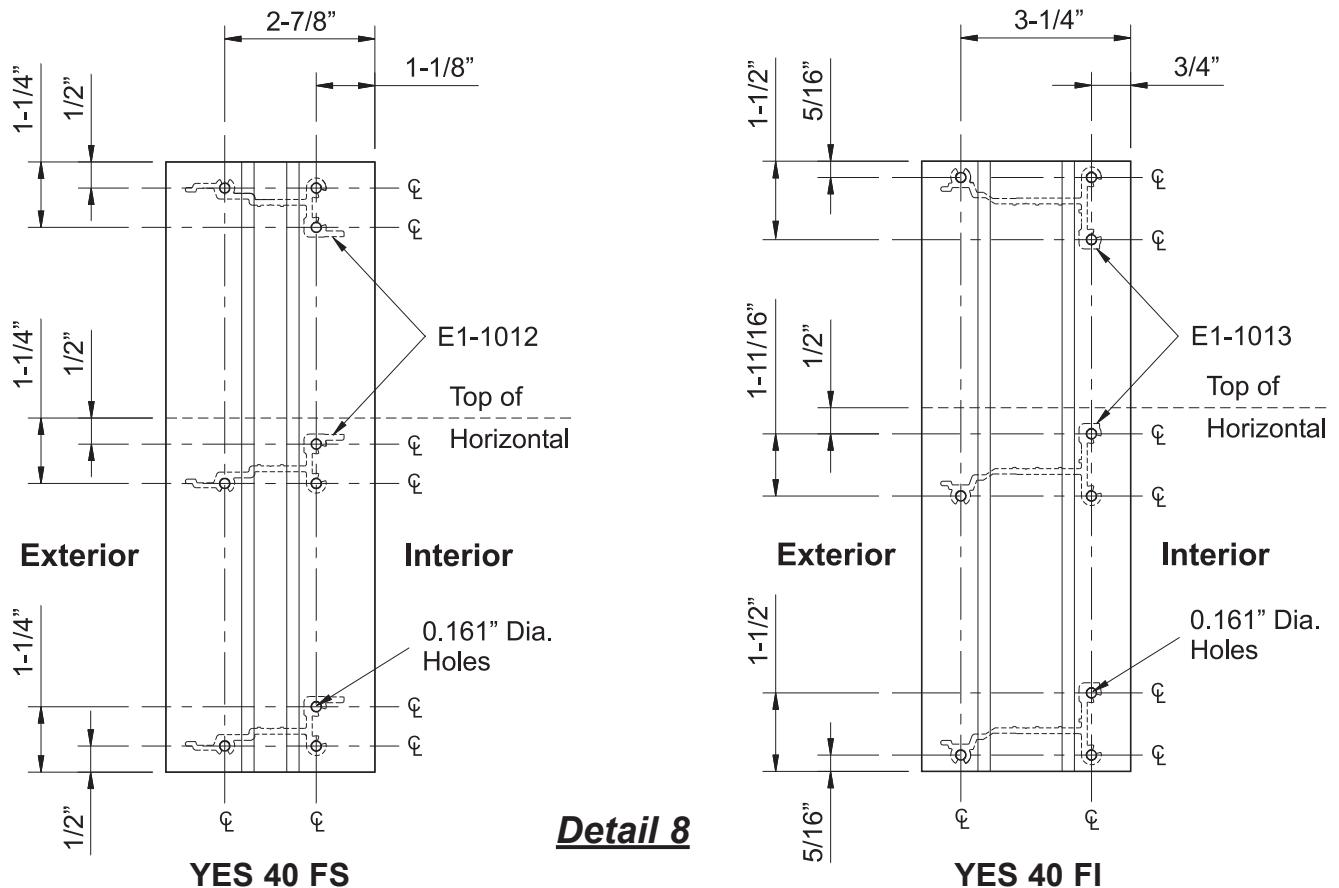

## FRAME FABRICATION

### STEP 5 FABRICATE HEAD, HORIZONTAL & SILL MEMBERS

-Cut head, sill and horizontal members to the daylight opening between verticals.

-Members that are to be attached to shear blocks require additional fabrication:

**Head Members:** Mark a hole location at each end, 1" from the ends centered along the glazing pocket "V"-groove.

**YES 40 FS horizontal and sill members:**  
Mark a hole location at each end, 1" from the ends centered along the glazing pocket "V"-groove.

**YES 40 FI horizontal and sill members:**  
Measure up 1/4" from the glazing pocket and mark a hole location at each end, 1" from the ends.

-Drill a 0.236" diameter hole (# B drill bit) at each location marked.

See **Detail 9**.

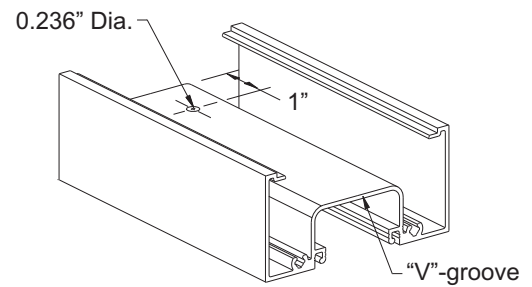

**YES 40 FI Head Shown  
YES 40 FS Similar**

### Detail 9

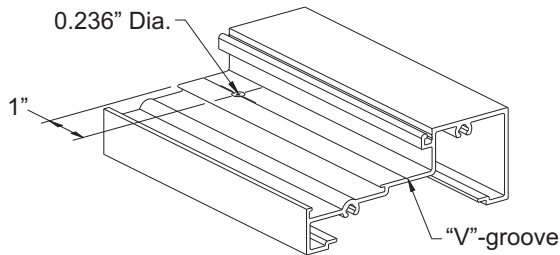

**YES 40 FS  
Horizontal/Sill**

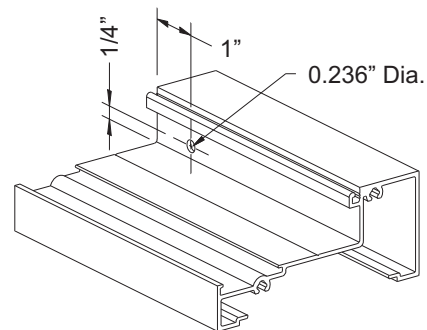

**YES 40 FI  
Horizontal/Sill**

### STEP 6 FABRICATE GLASS STOPS & GLAZING ADAPTORS

-Cut glass stops to the same dimensions as their respective horizontals minus(-) 1/32".

-Cut glazing adaptors to the daylight opening minus(-) 1/32".



## FRAME ASSEMBLY

### STEP 7 ASSEMBLE FRAMES

#### Screw Spline Assembly:

- Clean all joint surfaces using cleaner approved by sealant manufacturer.
- Apply (butter) sealant to both ends of head, horizontal and sill members just prior to assembly.
- Attach head, horizontal and sill members to vertical members with two (2) PC-1216 fasteners at each end.

**Note:** Fasteners PC-1220 must be substituted for PC-1216 when the head member (with screw splines) is used as a vertical.

- Tool the sealant into the joints and wipe away any excess sealant.

See **Detail 10**.

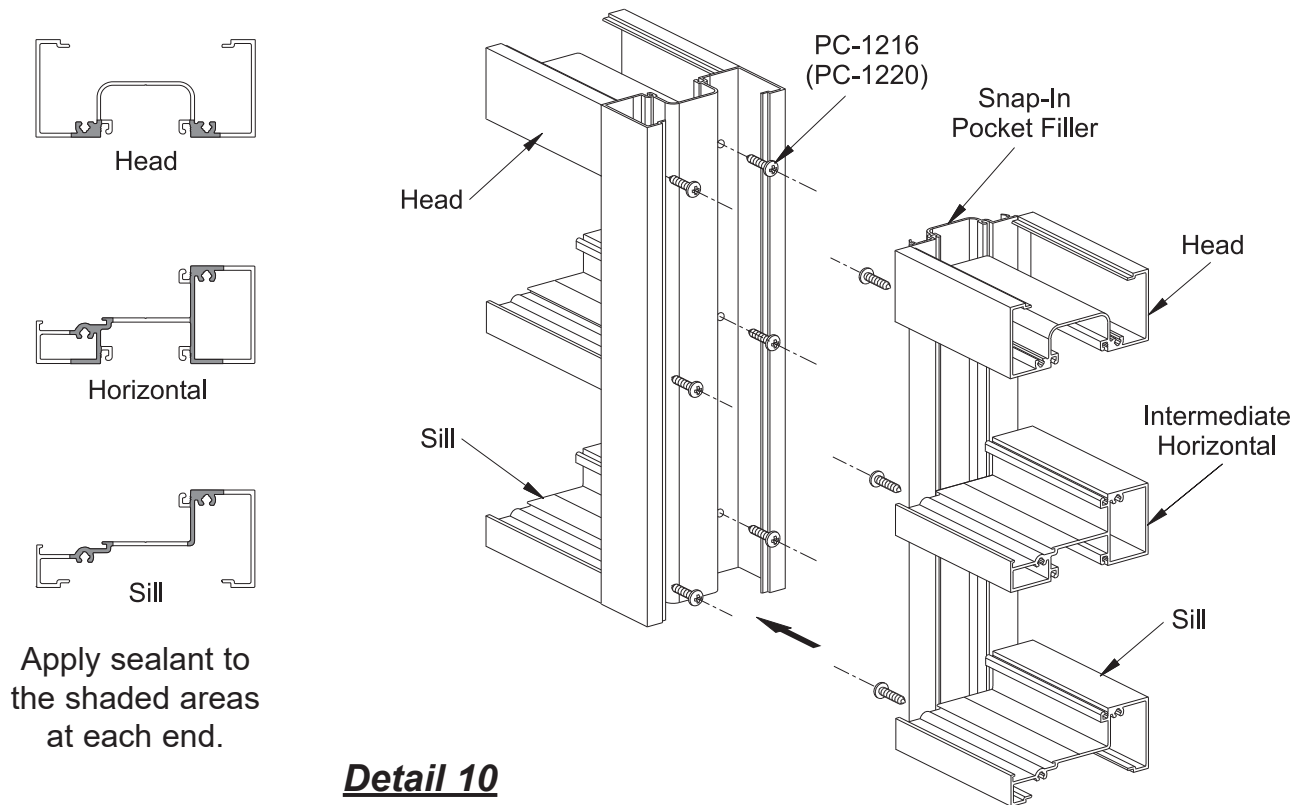

Apply sealant to the shaded areas at each end.

#### **Detail 10**

YES 40 FI Shown  
YES 40 FS Similar

**CAUTION:** Always assemble frames such that each lite of glass will have a minimum of one deep vertical glazing pocket.

## FRAME ASSEMBLY

### STEP 7 (Continued) ASSEMBLE FRAMES

#### Shear Block Assembly:

- Clean all joint surfaces using cleaner approved by sealant manufacturer.
- Apply (butter) sealant to both ends of head, horizontal and sill members.
- Apply sealant to the shear blocks as shown.
- Attach head members to shear blocks at each end with one (1) FC-1208 fastener.
- Attach horizontal and sill members to shear blocks at each end with:
  - one (1) PB-1206 fastener for YES 40 FS.
  - one (1) PC-1210 fastener for YES 40 FI.

**Note:** Open back horizontals must be used with shear blocks at end bays.

See **Detail 11**.

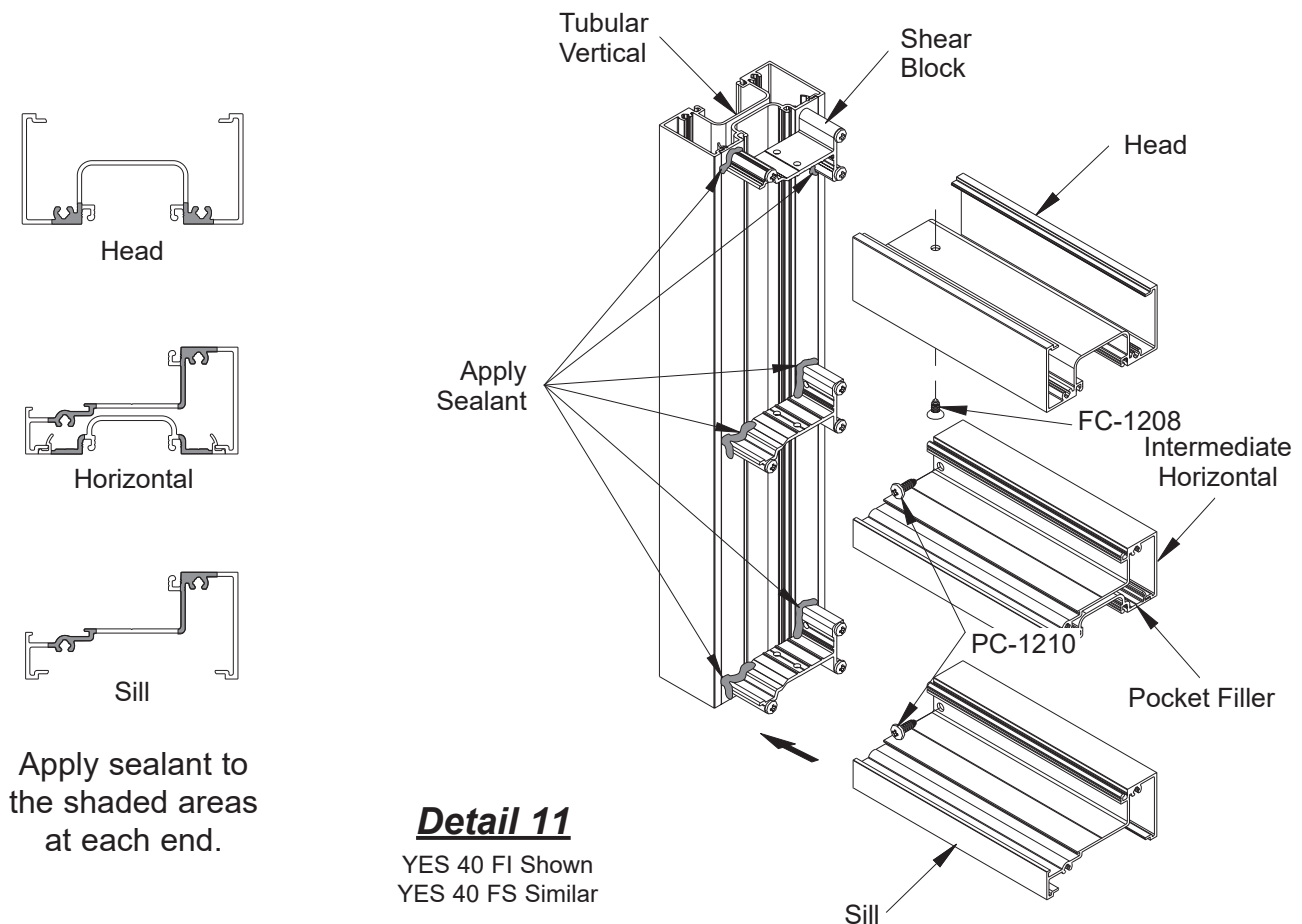

Apply sealant to the shaded areas at each end.

**CAUTION:** Always assemble frames such that each lite of glass will have a minimum of one deep vertical glazing pocket.

## FRAME ASSEMBLY

### STEP 8 (Not necessary with Head Receptor) INSTALL FOAM PLUGS AT HEAD

-Cut pieces of E2-0259 foam backer tape (maximum 1-7/8" long for typical mullion) to be adhered at the head only.

These will serve as end cap support for perimeter backer rods and sealant.

-Peel the adhesive tape from the foam pieces and adhere them to the front and back of the mullion as shown in **Detail 12**. The foam can be easily compressed to accommodate obstacles in the assembled verticals.

**Notes:** For best adhesion, ensure the contact surfaces of the verticals are clean and dry.  
Backer tape application is similar for expansion and corner mullions

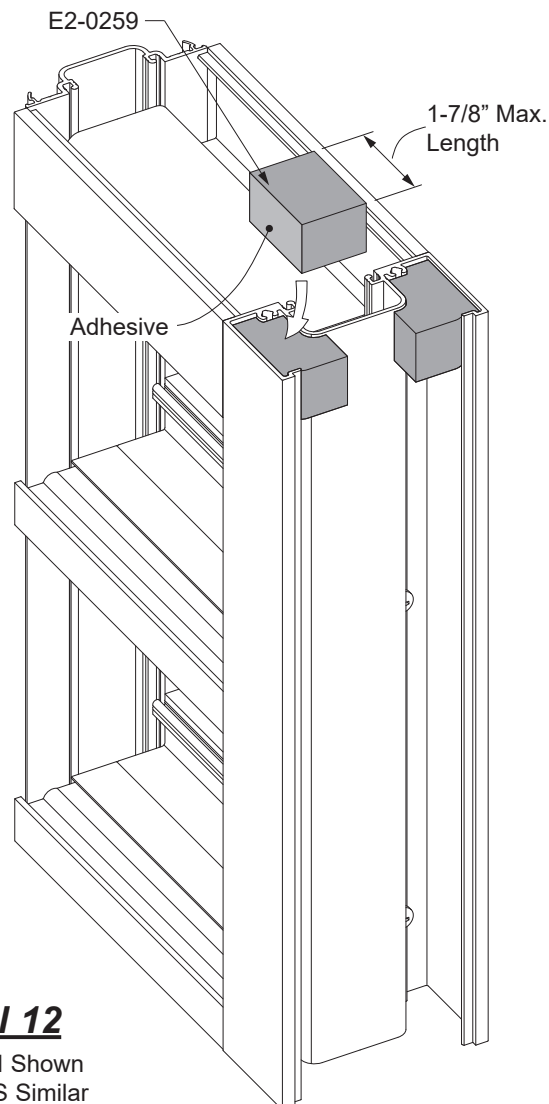

### **Detail 12**

YES 40 FI Shown  
YES 40 FS Similar

**FRAME INSTALLATION**

**STEP 9  
INSTALL SILL FLASHING**

- Clean all joint surfaces using cleaner approved by sealant manufacturer.
- Apply sealant to each end of the sill flashing.
- Apply sealant to the contact surfaces of the E1-1147 end dam and adhere it to each end of the sill flashing.

See **Detail 13A**.

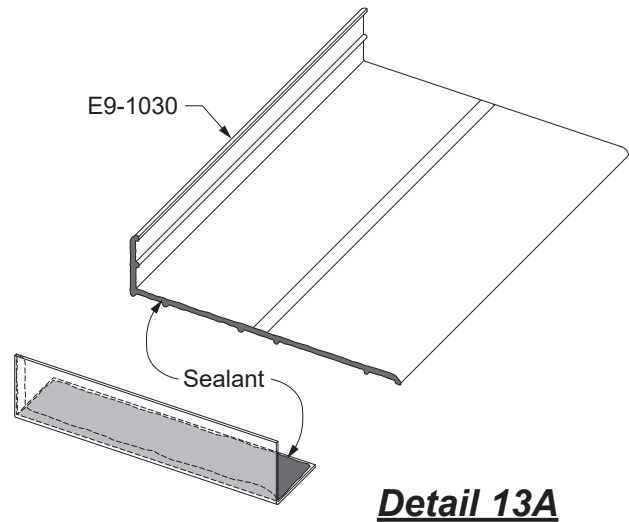

- Apply and tool sealant along the joint between the end dam and the sill flashing. Tape down the back corners to hold the end dam in place until the sealant cures.

See **Detail 13B**.

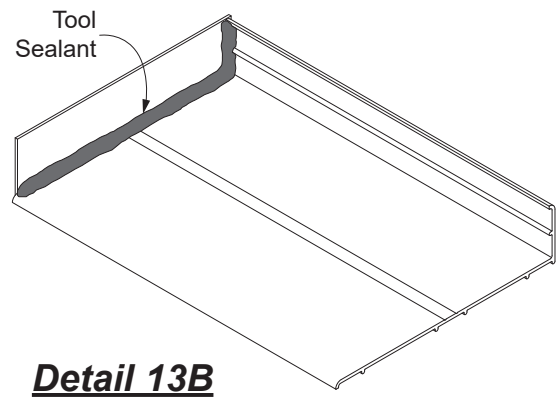

## FRAME INSTALLATION

### STEP 9 (Continued) INSTALL SILL FLASHING

- Starting at the smallest opening height, install the sill flashing with a minimum of 3/8" shim underneath. Sill flashing must be installed level.
- Anchor the sill flashing to the structure a maximum of 4" from each end and then 18" to 24" on center.
- Apply and tool sealant to cover the heads of all fasteners.

The sill flashing must be spliced every twelve to fifteen feet using splice sleeve, E1-1146:

- Apply bond breaker tape to center of the splice sleeve on the underside.
- Apply a generous amount of sealant to both sides of the sill flashing splice.
- Center the splice sleeve over the 3/8" splice joint.
- Tool the sealant up and over the edges of the splice sleeve to completely seal the joint.
- Apply and tool sealant at the front and back faces of the splice joint.

See **Detail 14**.

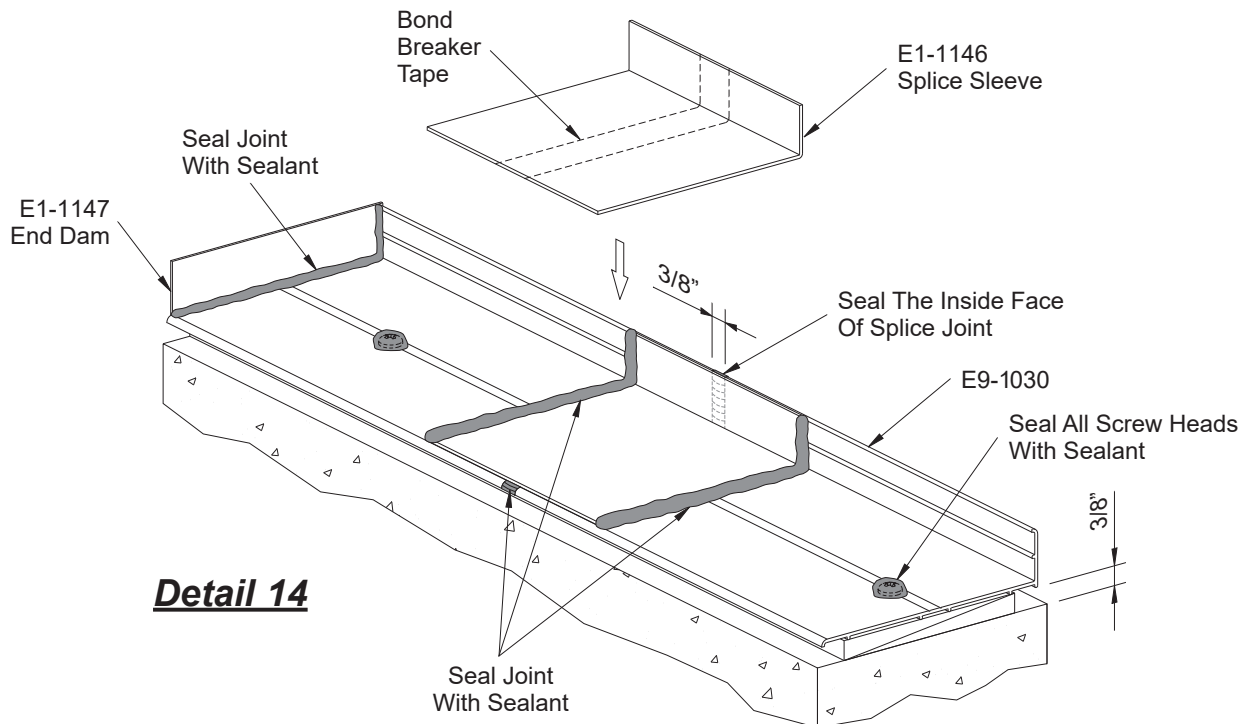

**FRAME INSTALLATION**

**STEP 10  
ATTACH HEAD RECEPTOR END CAPS**

-Cut E2-0051 bulb gaskets to the same length as the head receptor and insert them into the reglet of both the BE9-2562 head receptor and E9-1033 snap cover. See **Detail 15**.

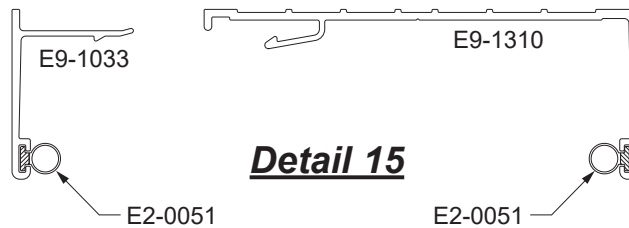

- Clean all joint surfaces using cleaner approved by sealant manufacturer.
- Apply sealant to the end of the head receptor as shown in **Detail 16**.
- Fasten the E1-2603 end caps to each jamb using two UA-1212 fasteners.
- Tool sealant to the inside of the end caps at the jambs similar to that for the sill flashing end dams (see **Detail 18**). Tape down the top corners to hold the end cap in place until the sealant cures.

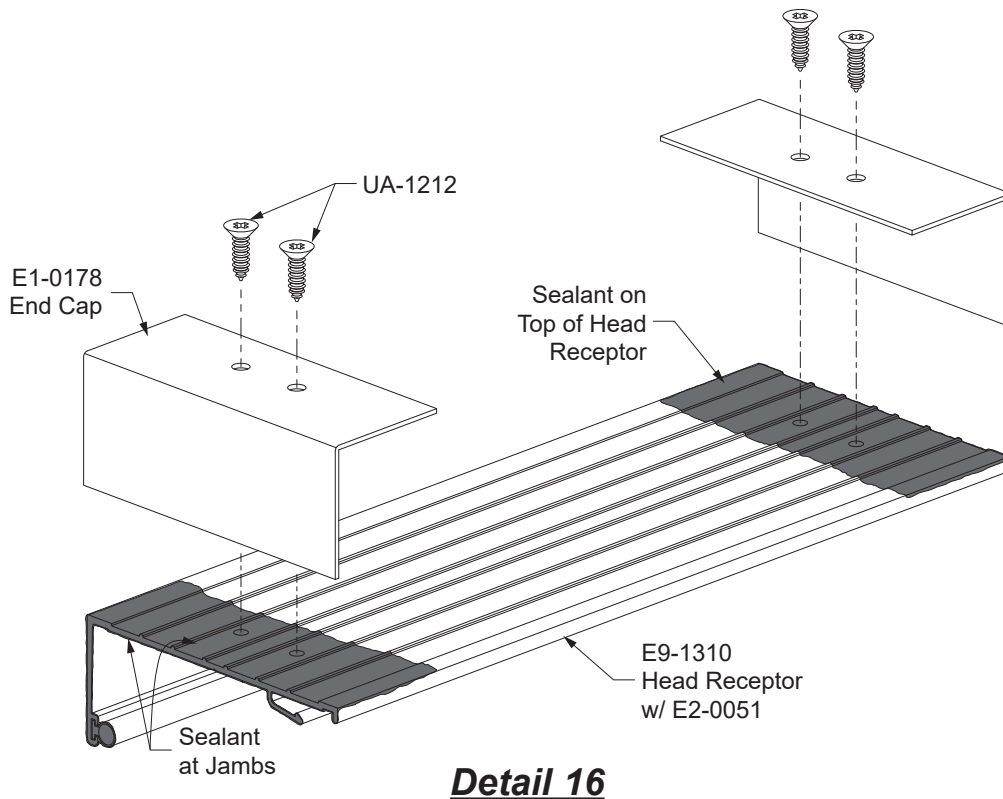

## FRAME INSTALLATION

### STEP 10A INSTALL HEAD RECEPTOR

-Install the BE9-2562 head receptor to the substrate using fasteners per approved shop drawing or P.E. calculations.

Allow for a 3/8" shim space to the substrate and a 3/8" gap at the splice joints.

-Seal all anchor fastener heads.

See **Details 17 & 18.**

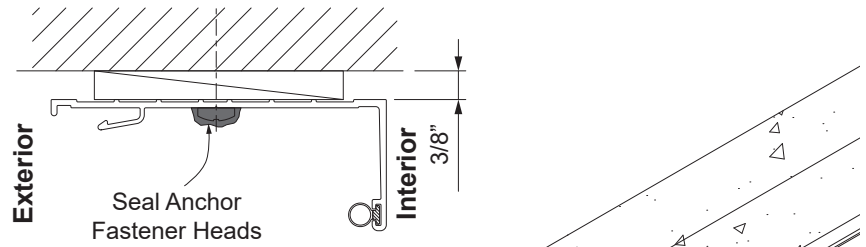

**Detail 17**

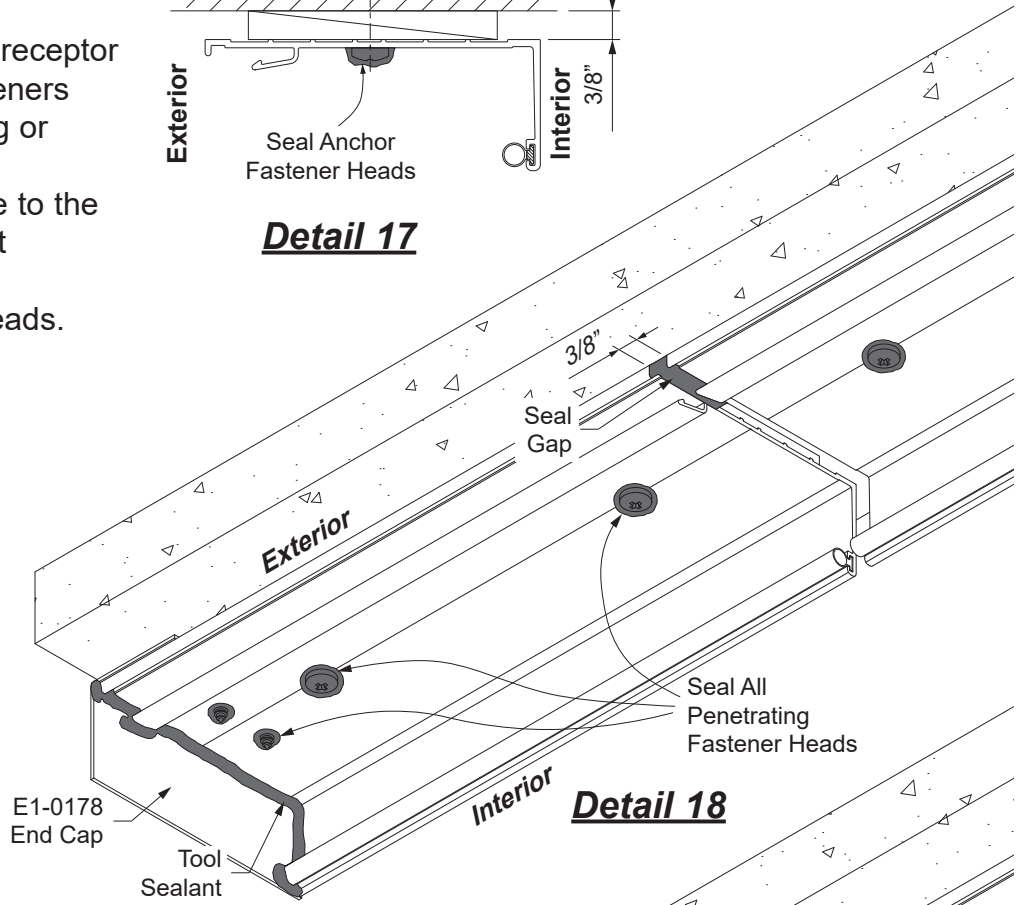

-Adhere an E2-0070 silicone sheet to the splice joints on a bed of sealant. Fill the gaps at the front and back of the head receptor with sealant.

See **Detail 19.**

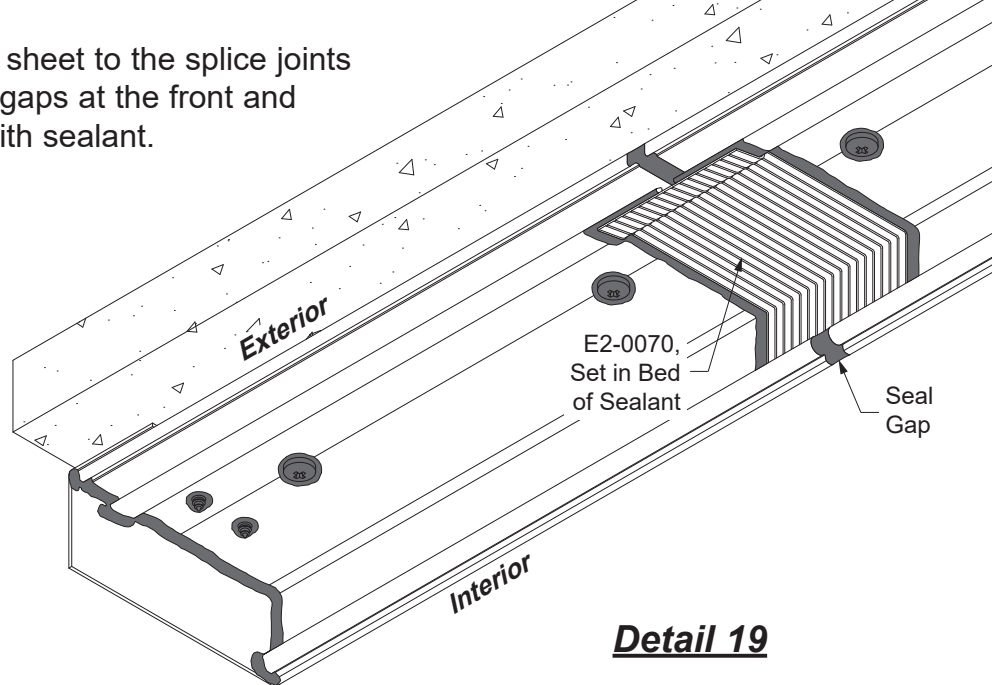

## FRAME INSTALLATION

### STEP 11 INSTALL FRAMES

- Snap in flat fillers, E1-1054, or 2-1/2" long pieces of E9-1038 at head, jamb, and sill anchor locations.
- Snap assembled frames together if using screw spline assembly.
- Apply sealant to the front of the back leg of the sill flashing and immediately set the frame into the opening.

See **Detail 20**.

- Shim jamb and head members with a minimum of 3/8" shim.
- Anchor the frame to the structure at the sill\*, head, and jamb: 3" from the ends and then 18" to 24" on center.
- Always install a shim at all anchor locations.
- Seal all screw heads.

**Note:** Use only flat head fasteners at head and jamb conditions.

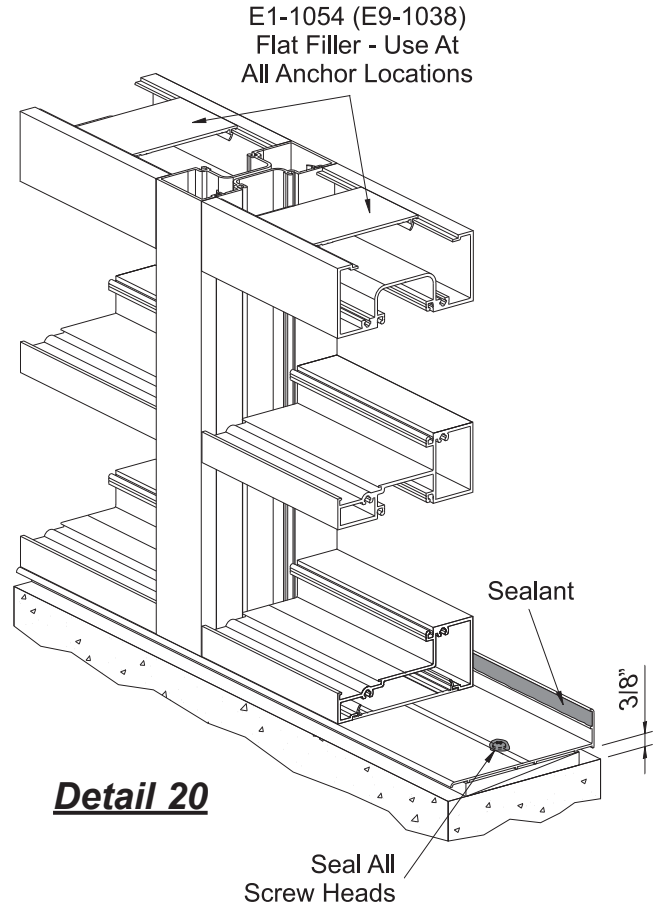

**Detail 20**

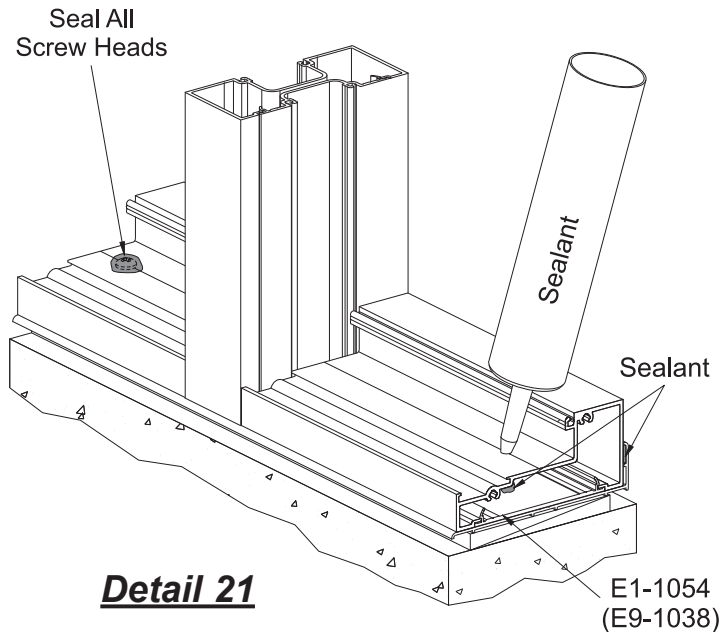

**Detail 21**

\*Sill anchors penetrate the sill flashing and must be sealed watertight.

Prior to installing sill anchors:

- Force sealant down through the anchor holes in the sill member
- Apply sealant to the screw threads of the sill anchor fastener.

-Apply and tool sealant to cover the sill anchor screw heads.

See **Detail 21**.



## FRAME ASSEMBLY

### STEP 11 (Continued)

### INSTALL FRAMES W/ HEAD RECEPTOR

- Rotate the assembled frames into position from the exterior, ensuring engagement into the sill flashing.
- Snap on the E9-1033 snap cover (with E2-0051 bulb gasket) into the head receptor.
- For mullion end load reactions over 500 lbs., attach the sill to the sill flashing using PM-1008-SS screws. Also add one (1) PM-1008-SS fastener 2" in both directions from the center line of the splice.

See **Detail 22**.

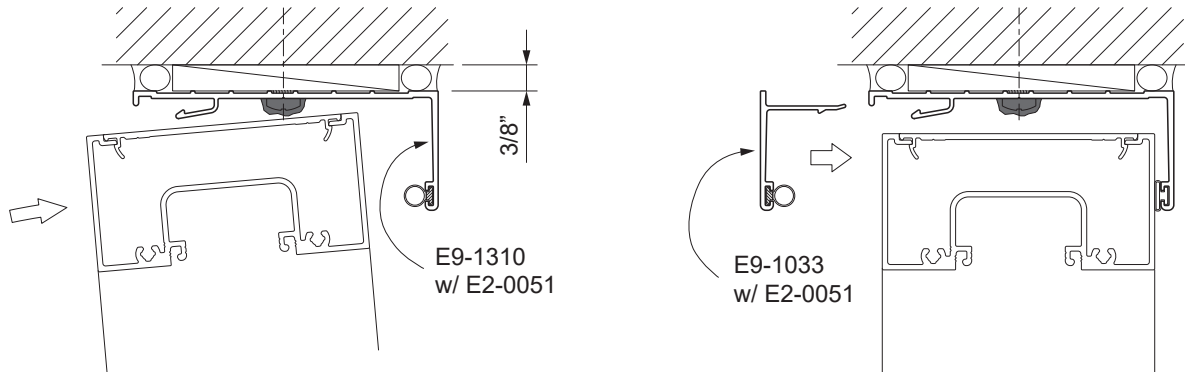

### **Detail 22**

YES 40 FI Shown  
YES 40 FS Similar

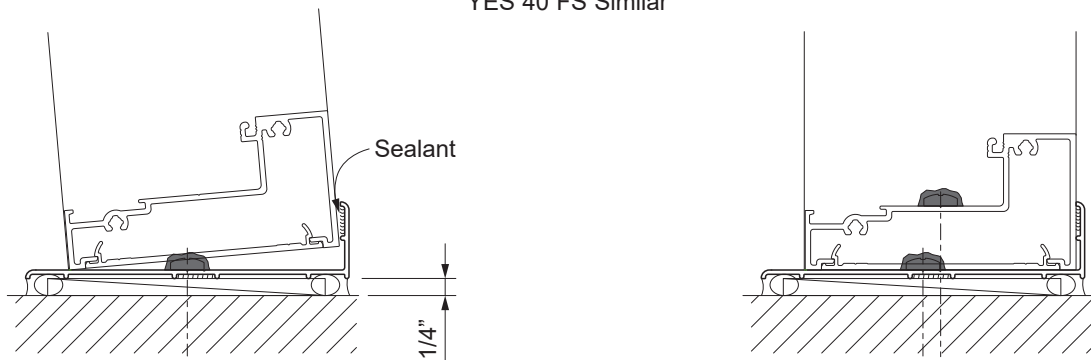

**FRAME INSTALLATION**

**STEP 11 (Continued)  
INSTALL FRAMES**

Prior to snapping the assembled frames into the door jamb, the end of the sill flashing needs to be sealed to the door jamb.

- Apply and tool sealant to all sill flashing to door jamb joints.
- Apply a liberal amount of sealant to completely fill the door jamb cavity and ramp the sealant down onto the sill flashing.

See **Detail 23**.

Refer to the **20D, 35D, & 50D Entrances Installation Manual** for door installation instructions.

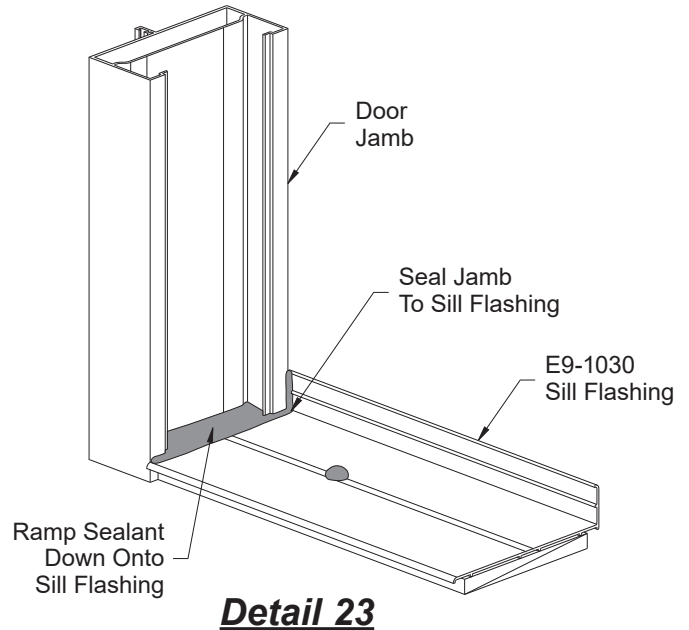

**STEP 12  
APPLY PERIMETER SEALANT**

- Install backer rod around the perimeter of the frame.
- Apply perimeter sealant to the joint between the frame and the structure.
- Do not** seal the joint between the sill and the sill flashing.
- Make sure all screw heads are sealed.

See **Detail 24**.

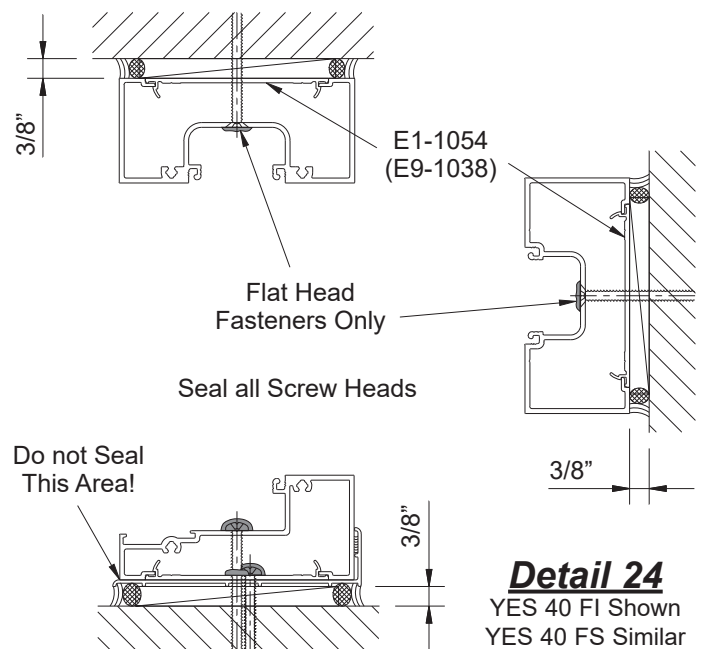

## FRAME INSTALLATION

### STEP 12A

### APPLY PERIMETER SEALANT @ HEAD RECEPTOR

-Insert a 1" long piece of backer rod into the gap at the exterior head receptor snap cover between the head member and the head receptor.

See **Detail 25**.

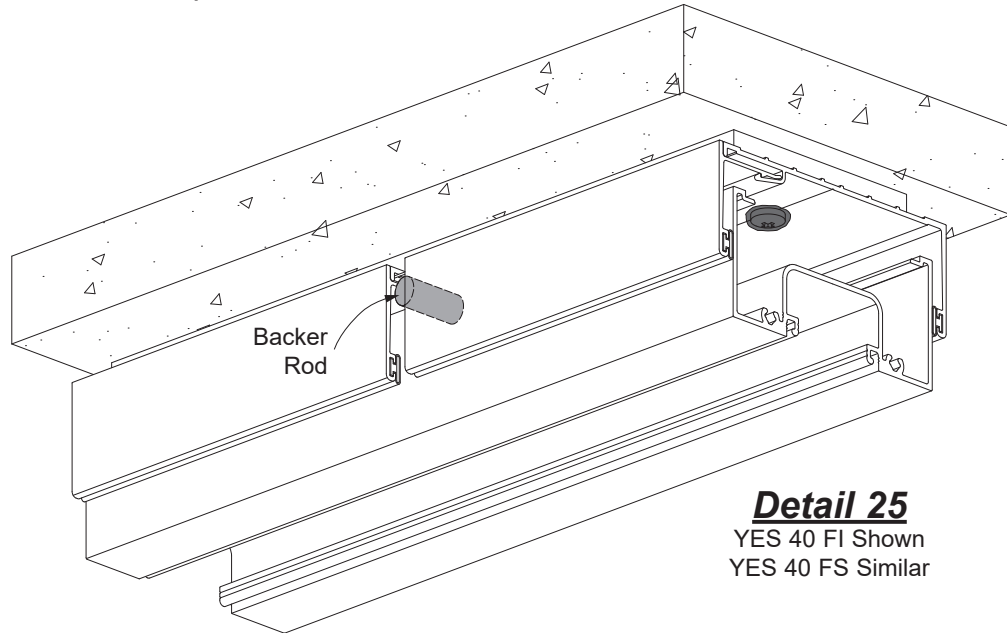

-Insert a continuous backer rod between the head receptor and substrate on both the interior and exterior of the frame.

-Apply and tool continuous sealant along the caulk joint and fill the gap at the exterior snap cover with sealant.

See **Detail 26**.

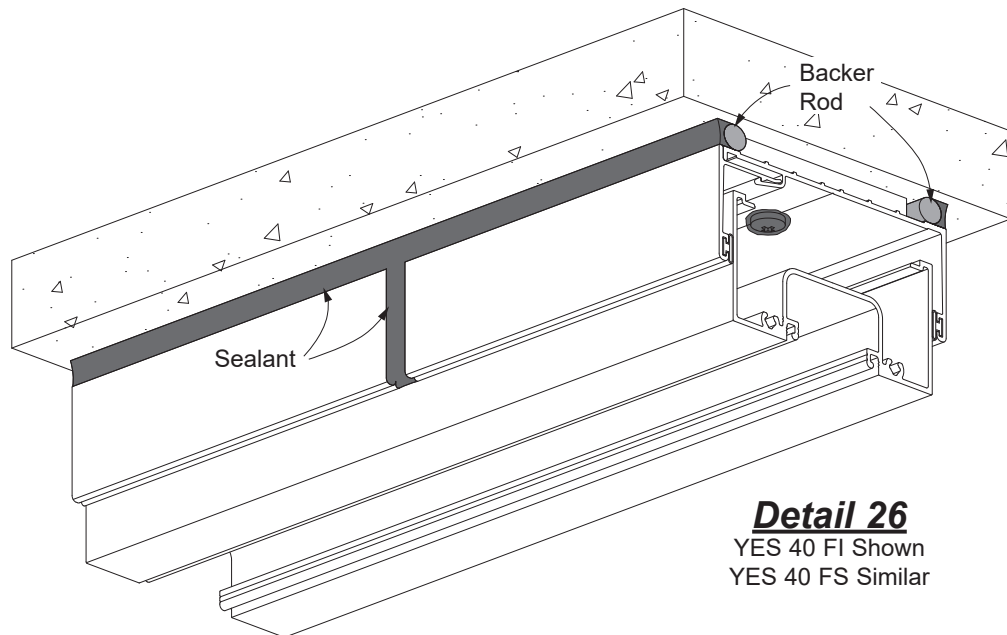

## FRAME INSTALLATION

### STEP 13 INSTALL WATER DEFLECTORS

YES 40 FS/FI requires the installation of water deflectors, E2-0047 (for 1" glazing) or E2-0048 (for 1/4" glazing), at each end of the intermediate horizontals. Water deflectors aid to properly divert water away from the framing system.

-Peel away the protective paper from the bottom of the water deflector and install the water deflector by rotating it over each end of the horizontal.

See **Detail 27**.

-Position the vertical leg of the water deflector against the end of the horizontal.

**Note:** For best adhesion, make sure that the horizontal is clean and dry.

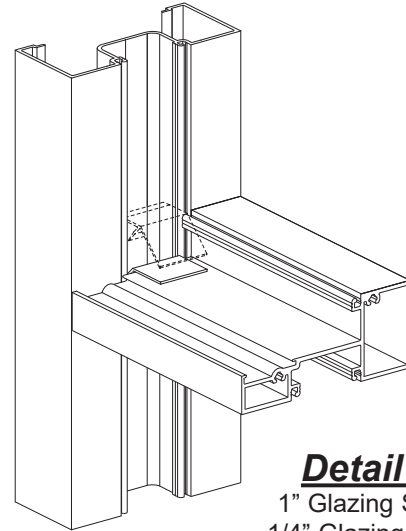

**Detail 27**  
1" Glazing Shown  
1/4" Glazing Similar

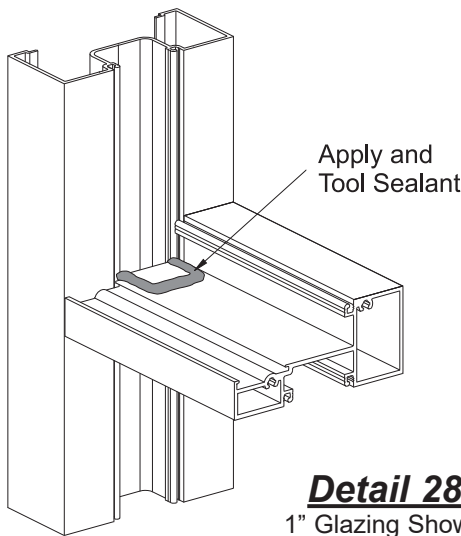

**Detail 28**  
1" Glazing Shown  
1/4" Glazing Similar

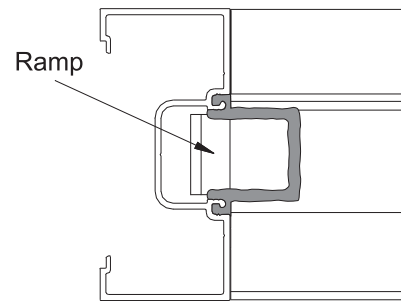

**Detail 29**  
1" Glazing Shown  
1/4" Glazing Similar

-Apply and tool sealant along the edges of the water deflector and down onto the horizontal.  
See **Detail 28**.

-Seal the ramp of the water deflector to the sides of the vertical gasket reglets.  
See **Detail 29**.

## FRAME INSTALLATION

### STEP 14

#### APPLY INTERNAL SEALANT

- Apply a generous amount of sealant to the vertical intersection of the horizontal and vertical members.
- Tool all of the sealant to ensure a water tight joint.
- Make sure all exposed screw heads are sealed.

See **Detail 30**.

#### **Detail 30**

YES 40 FI Shown  
YES 40 FS Similar

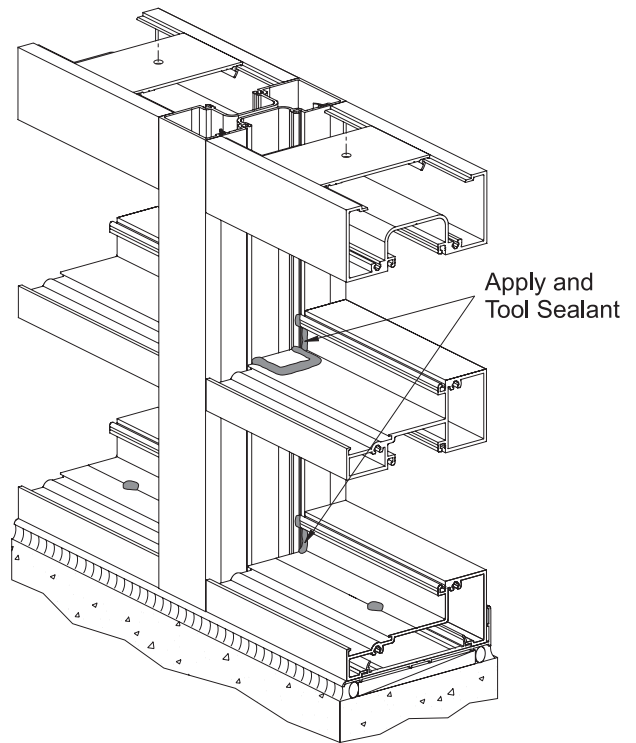

Seal Corners  
Of Glazing Adaptors

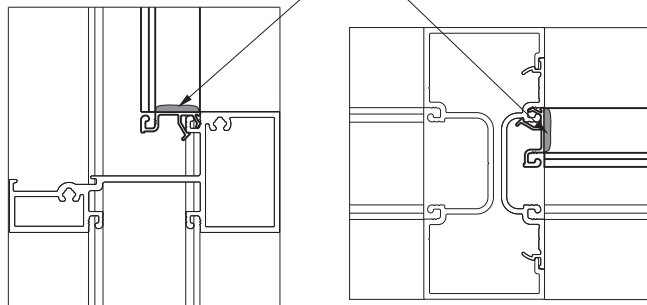

Horizontal

Vertical

#### **Detail 31**

### STEP 15 (Optional)

#### INSTALL GLAZING ADAPTORS

Glazing adaptors, E9-1039 and E9-1040, allow for glazing infills other than the standard 1/4" or 1". Please refer to the glazing tables on the right for possible adaptor/gasket combinations.

- Snap glazing adaptors into the interior gasket reglets of the verticals.
- Snap glazing adaptors into the interior gasket reglets of the horizontals.
- Apply and tool sealant to the joint between vertical and horizontal glazing adaptors.

See **Detail 31**.

#### Glazing Table - YES 40 FS

Glass Thickness	Exterior	Interior
3/16"	E2-0052	E2-0064
1/4"	E2-0052	E2-0052
5/16"	E2-0053	E2-0052
3/8"	E2-0053	E2-0053

#### Glazing Table - YES 40 FI

Glass Thickness	Adaptor	Exterior	Interior
3/16"	E9-1040	E2-0052	E2-0064
1/4"	E9-1040	E2-0052	E2-0052
5/16"	E9-1040	E2-0053	E2-0052
3/8"	E9-1040	E2-0053	E2-0053
1/2"	E9-1039	E2-0064	E2-0064
5/8"	E9-1039	E2-0052	E2-0052
3/4"	E9-1039	E2-0053	E2-0053
7/8"	—	E2-0064	E2-0064
1"	—	E2-0052	E2-0052

## GLAZING

### STEP 16 INSTALL INTERIOR GLAZING GASKETS

The interior glazing gaskets must be installed prior to the glazing process.

-Using a small brush clean out any dirt that may have accumulated in the gasket reglets.

Vertical glazing gaskets must be installed first:

- Cut vertical glazing gaskets to Daylight Opening plus(+) 3/16" for each foot of length.
- Insert the gasket into the reglet at each end first, and then insert the gasket at the midpoint of the opening.
- Push the gasket into the reglet starting at the midpoint and work towards each end.

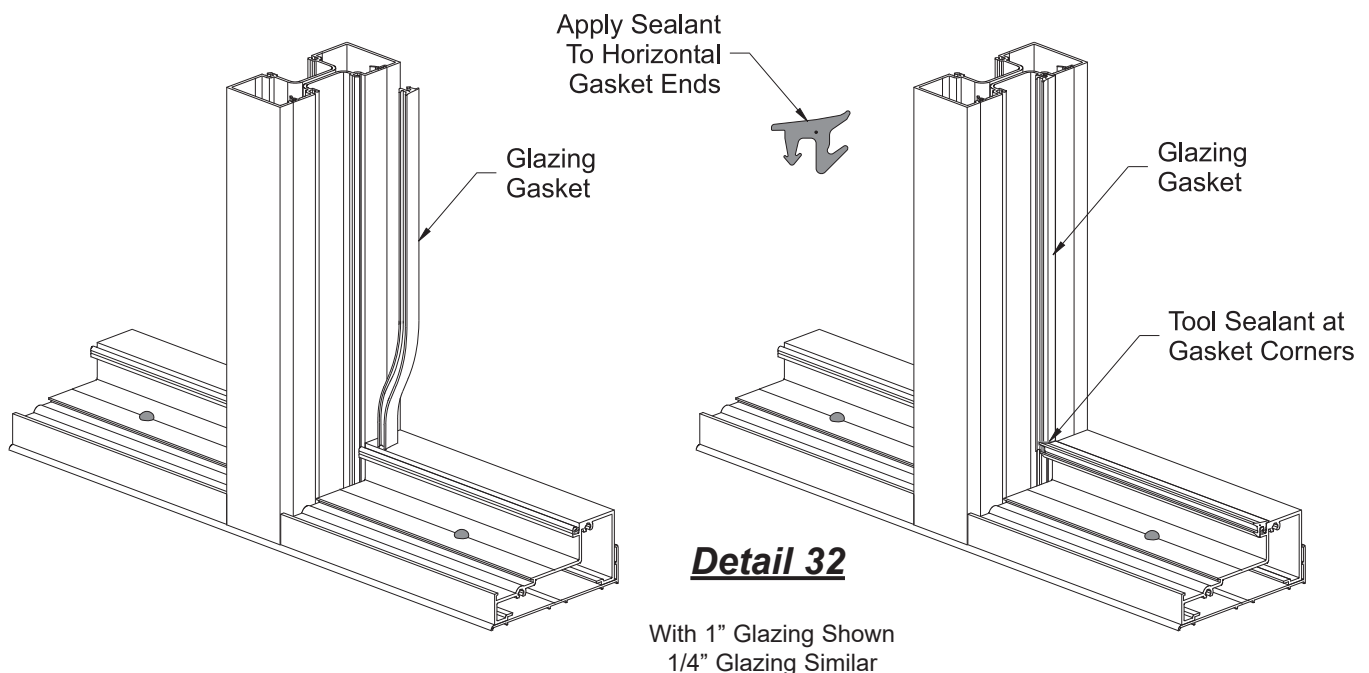

Install horizontal glazing gaskets next:

- Cut horizontal glazing gaskets to Daylight Opening plus(+) 3/16" for each foot of length.
- Apply sealant to each end of the horizontal glazing gasket prior to inserting into the reglet.
- Insert the gasket into the reglet at each end first and push each end tight against the vertical gasket.
- Then insert the gasket at the midpoint of the opening and push the gasket into the reglet starting at the midpoint and work towards each end.
- Tool the excess sealant at the gasket corners to ensure a watertight seal.

See **Detail 32**.

## GLAZING

### STEP 17 INSTALL GLASS

Determine the glass size:

	1/4" Glass Size	1" Glass Size
Vertical	D.L.O. + 5/8"	D.L.O. + 7/8"
Horizontal	D.L.O. + 5/8"	D.L.O. + 7/8"

- Carefully install the glass into the opening: bring the lite up and into the deep pocket first and then rotate the other end in place.
- Carefully lift lite of glass, install setting blocks at quarter points of horizontal D.L.O. or according to engineering calculations.
- Make sure the glass is engaged with all setting blocks.

See **Detail 33**.

\* **Note:** For 1" glazing glass bite is 7/16".

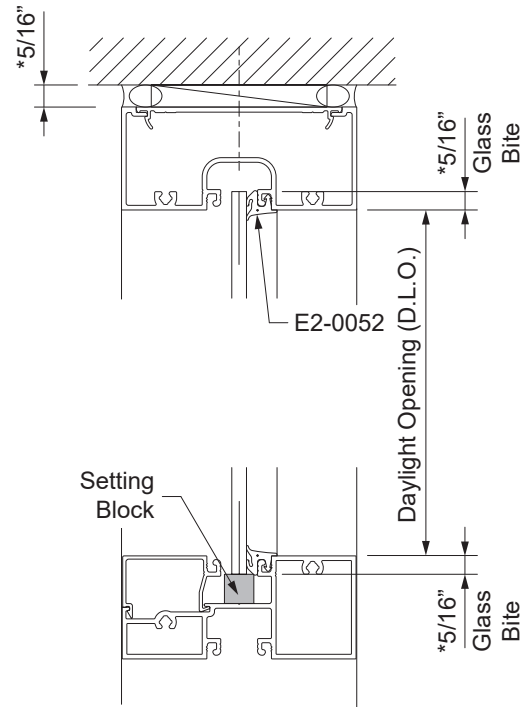

### ***Detail 33***

1/4" Glazing Shown  
1" Glazing Similar

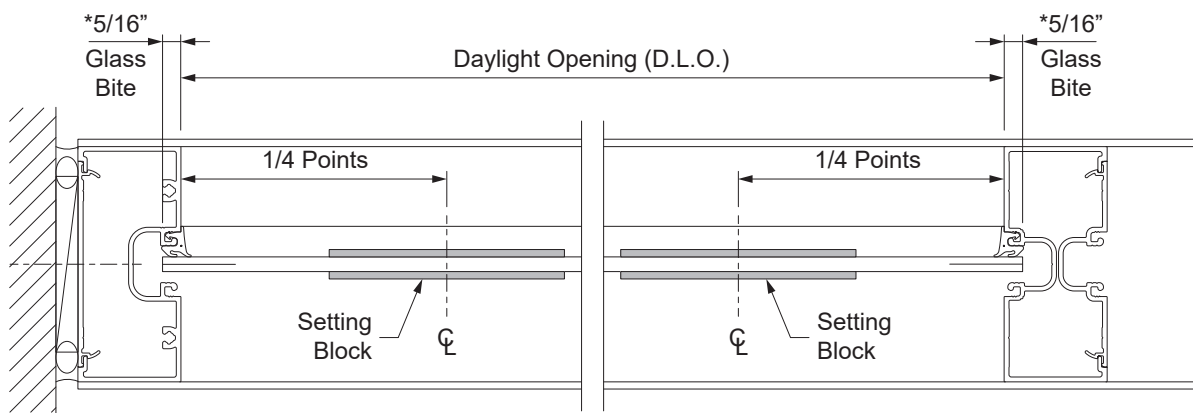

**GLAZING**

**STEP 18 (YES 40 FI Only)  
INSTALL ANTI-WALK BLOCKS**

YES 40 FI frames require the installation of an anti-walk block, E2-0153, in the vertical deep glazing pocket of each lite centered along the daylight opening.

-Flatten the anti-walk block against the exterior surface of the glass and push it into the opening between the glass and the mullion until it is released into the glazing pocket.

See **Detail 34**.

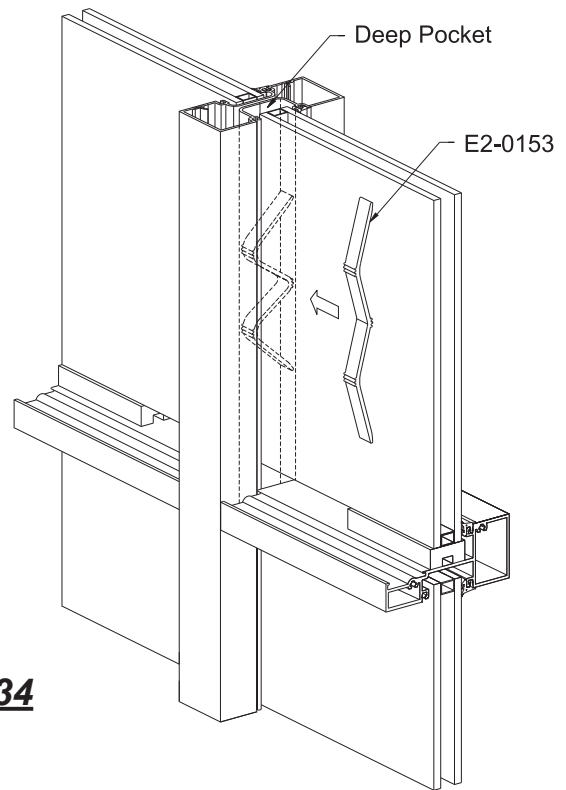
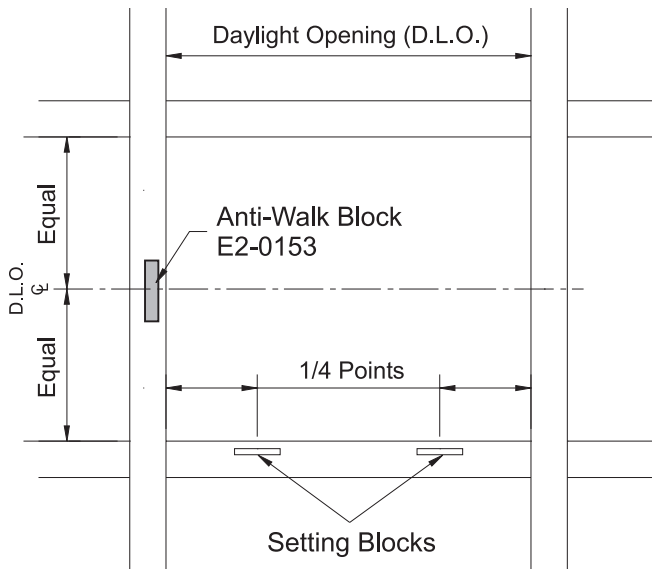

**Detail 34**

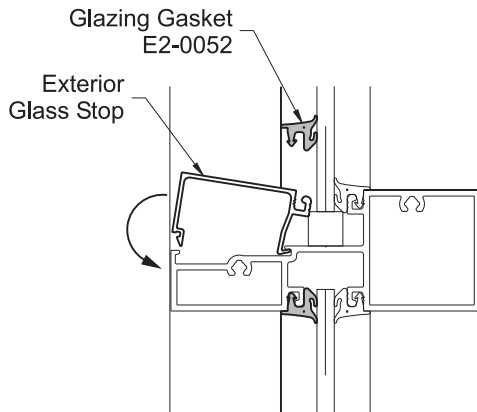

**Detail 35**

1/4" Glazing Shown  
1" Glazing Similar

**STEP 19  
INSTALL EXTERIOR GLASS STOPS  
& GLAZING GASKETS**

-Snap the exterior glass stops into place as shown in **Detail 35**.

-Install the exterior glazing gaskets using the same technique described in **Step 16** on **Page-26**. Always install the vertical glazing gasket first.

Repeat **Steps 16 through 18** until all lites are installed.







101 Marietta Street NW  
Suite 2100  
Atlanta, Georgia 30303  
[www.ykkap.com](http://www.ykkap.com)