

# YHS 50 TU Storefront System

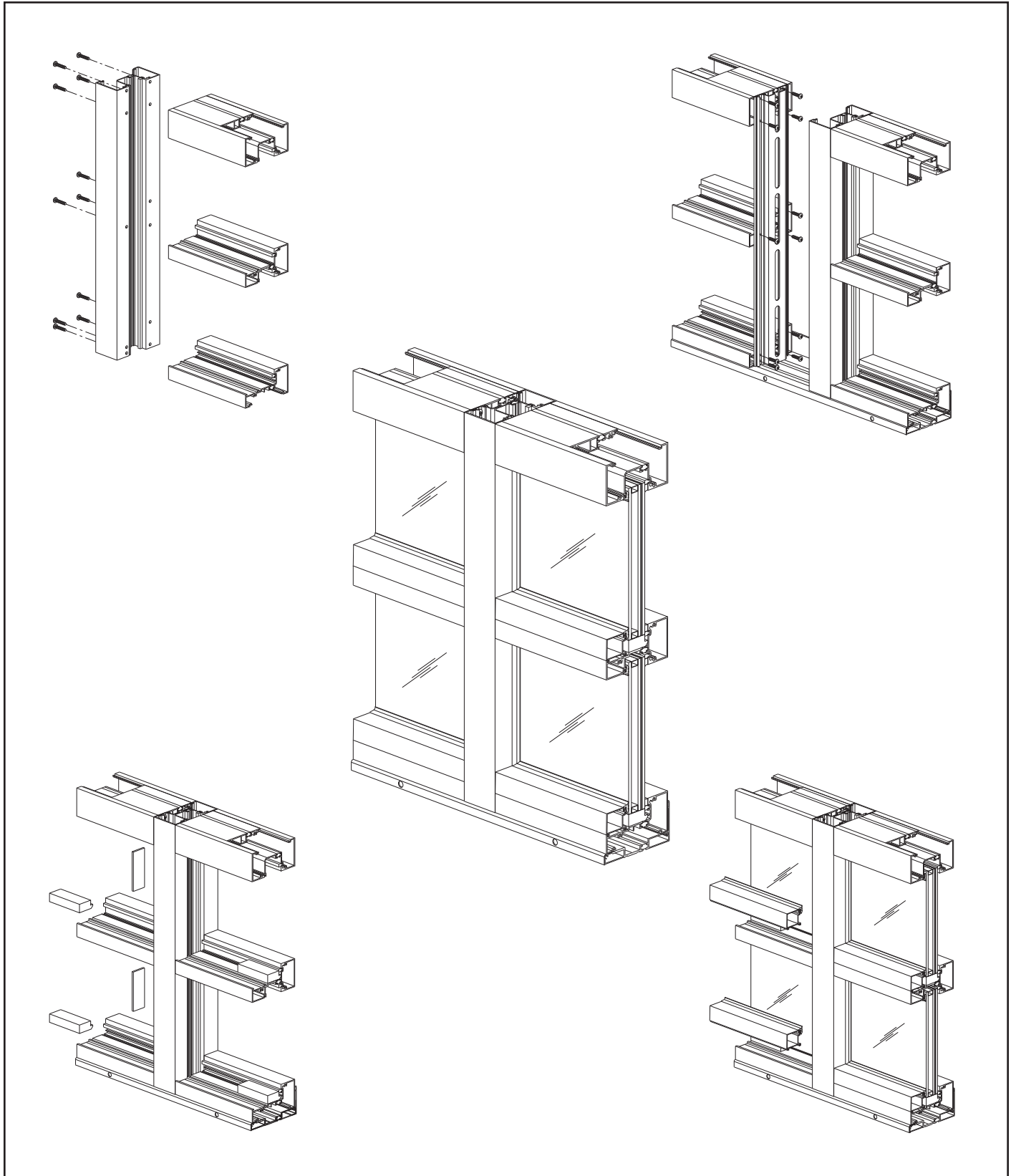

## Installation Manual



## TABLE OF CONTENTS

Installation Notes .....	Page ii
<b>PARTS DESCRIPTION</b>	
YHS 50 TU Framing Members .....	Pages 1 & 2
YHS 50 TU Accessories .....	Pages 2 & 3
<b>FRAME FABRICATION</b>	
Determine Frame Dimensions .....	Page 4
Fabricate Sill Flashing .....	Page 5 to 7
Fabricate Vertical Mullions & Pocket Fillers .....	Page 8 to 10
Fabricate Head, Horizontal & Sill Members .....	Page 11
Fabricate Glass Stops .....	Page 11
<b>FRAME ASSEMBLY</b>	
Install Structural Silicone Spacers .....	Page 12
Assemble Frames .....	Page 12 & 13
Install Sill Flashing End Dams .....	Page 14
<b>FRAME INSTALLATION</b>	
Install Sill Flashing .....	Page 15 & 16
Sill Fabrication .....	Page 16
Install Sill Flashing at Corners .....	Page 17
Prepare Door Jambs (Air Threshold Only) .....	Page 18
Install Storefront Frames .....	Pages 19 to 21
Install Water Deflectors .....	Page 22
Apply Perimeter Sealant .....	Page 23
<b>GLAZING</b>	
Determine Glass Size .....	Page 24
Glazing .....	Pages 25 to 29







## Installation Notes

1. Do not drop, roll or drag boxes of aluminum framing. Move and stack boxes with proper support to prevent distortion. If fork lifts are used be especially careful about striking the boxes when lifting or moving.
2. Store in a dry, out of the way area. If rain exposure, condensation or any water contact is likely, then all packaging material should be removed. Wet packaging materials will discolor and may stain aluminum finishes and paints.
3. All materials should be checked for quality and quantity upon receipt, YKK AP must be notified immediately of any discrepancies in shipment. Check to make sure that you have the required shims, sealants, supplies and tools necessary for the installation.
4. Carefully check the openings and surrounding conditions that will receive your material. Remember, if the construction is not per the construction documents, it is your responsibility to notify the general contractor in writing. Any discrepancies must be brought to the general contractor's attention before you proceed with the installation.
5. Gather your shop drawings, materials, packing list, and this installation manual. Carefully review parts location, the sequence it goes therein, when you glaze it and how you seal it. Installation instructions are of a general nature and may not cover every condition you will encounter. The shop drawings and/or installation manuals were prepared specifically for the product.
6. Any material substitutions must be of equal or greater quality.
7. Make certain that material samples have been sent for compatibility testing for all manufacturer's sealants involved. Only use sealants that are approved by YKK AP and make certain they have been installed in strict accordance with the manufacturer's recommendations and specifications:
8. Remember to isolate, in an approved manner, all aluminum from uncured masonry or other incompatible materials.
9. System-to-structure fasteners are not supplied by YKK AP. Fasteners called out on shop drawings are to indicate minimum sizes for design loading.
10. Entrances are to be installed plumb, square, level and true.
11. If any questions arise concerning YKK AP products or their installation, contact YKK AP for clarification before proceeding.
12. YKK AP storefront and/or curtain wall framing is typically completed before drywall, flooring and other products which may still be in process. Wrap and protect the material when stored at job site.
13. Cutting tolerances are plus zero (0"), minus one thirty second (-1/32") unless otherwise noted.
14. Check our website, [www.ykkap.com](http://www.ykkap.com), for the latest installation manual update prior to commencing work.

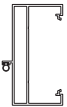









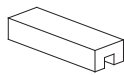

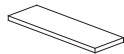
## FRAMING MEMBERS

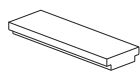
	<b>Head / Jamb / Vertical</b> 2-1/2" x 5"	<b>BE9-0681</b>		<b>Flat Filler</b> Use with 90° Corner Mullion E9-0659	<b>E9-0657</b>
	<b>IG Head</b> 2-1/2" x 5"	<b>BY7-9595</b>		<b>90° Corner Mullion</b> Use with E9-0656 and E9-0657	<b>E9-0659</b>
	<b>Horizontal</b> 2-1/2" x 5"	<b>BE9-0683</b>		<b>Sill Flashing</b>	<b>BE9-0687</b>
	<b>Horizontal</b> 5" x 5"	<b>BY7-8506</b>		<b>Expansion Mullion (Female)</b>	<b>BE9-0635</b>
	<b>IG Horizontal</b> 2-1/2" x 5"	<b>BE9-0638</b>		<b>Expansion Mullion (Male)</b>	<b>BE9-0634</b>
	<b>Sill</b> 2-1/2" x 5"	<b>BE9-0682</b>		<b>Transom Bar</b> Elastomer weathering E2-0051 included	<b>AS-0517</b>
	<b>IG Sill</b> 2-1/2" x 5"	<b>BY7-9597</b>		<b>OHCC Transom Bar</b> Use with AS-0218 Pile Weathering included	<b>AS-0521</b>
	<b>Snap Cover</b> for IG Horizontal	<b>Y7-9599</b>		<b>Transom Bar</b> Elastomer weathering E2-0051 included Use with 35HL/50HL Doors	<b>AS-0553</b>
	<b>Glass Stop</b>	<b>E9-0658</b>		<b>Door Stop</b> For OHCC Transom Bar Elastomer Weathering E2-0051 included	<b>AS-0218</b>
	<b>Heavy Duty Vertical</b> 2-1/2" x 5"	<b>BE9-0684</b>		<b>Transom Glazing Pocket Filler (35H)</b>	<b>E9-0515</b>
	<b>Shallow Pocket Filler</b> Use with E9-0651 or E9-0654	<b>BE9-0655</b>		<b>Transom Glazing Pocket Filler (35HL)</b>	<b>E9-0506</b>
	<b>Deep Pocket Filler</b> Use with E9-0659 & E9-0504	<b>E9-0656</b>		<b>Door Jamb</b> Elastomer weathering E2-0051 included	<b>AS-0504</b>

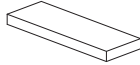

## FRAMING MEMBERS (Cont.)

	<b>Door Jamb</b> Elastomer weathering E2-0051 included Use with 35HL/50HL Doors	<b>AS-0551</b>		<b>Threshold Ramp</b>	<b>E9-0512</b>
	<b>Threshold Trim</b> Elastomer weathering E2-0051 included	<b>AS-0503</b>		<b>Threshold Ramp</b>	<b>E9-0513</b>
	<b>Water Resistant Threshold Gutter</b>	<b>E9-0502</b>		<b>Air Tight Threshold</b> Elastomer weathering E2-0051 included	<b>AS-0487</b>
	<b>Threshold Ramp</b>	<b>E9-0511</b>			

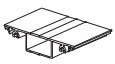



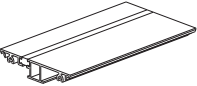
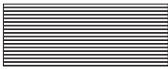



## ACCESSORIES

	<b>Setting Block</b>	<b>E2-0095</b>		<b>Interior Glazing Gasket</b> For small missile impacts	<b>E2-0088</b>
	<b>Side Block</b>	<b>E2-0096</b>		<b>Interior Silicone Spacer</b>	<b>E2-0084</b>
	<b>OHCC Transom Setting Block</b>	<b>E2-0092</b>		<b>Weathering Gasket</b> Use with BE9-0635 Expansion Mullion	<b>E2-0065</b>
	<b>IG Horizontal / Sill Setting Block</b>	<b>E2-9938</b>		<b>Door &amp; Reglaze Silicone Spacer</b>	<b>E2-0085</b>
	<b>Door Setting Block</b>	<b>E2-0086</b>		<b>Water Deflector</b> For Intermediate Horizontals	<b>E2-0049</b>
	<b>Push-in Glazing Gasket (7/16" F.C.)</b> Not Florida Approved	<b>E2-0081</b>		<b>Anti-Walk Block</b> For Jamb & Vertical Deep Pockets (Dry Glazed)	<b>E2-0807</b>
	<b>Exterior Glazing Gasket</b> For 1-5/16" Glazing	<b>E2-0083</b>		<b>Anchor Filler</b> For Door Jamb at Anchor Locations, 2-1/2" Long	<b>E1-1068</b>

ACCESSORIES (Cont.)

	<p><b>Anchor Filler</b> For Head &amp; Sill at Anchor Locations, 9" Long</p>	<p><b>E1-1060</b></p>		<p><b>Splice Sleeve</b> For Sill Flashing BE9-0687</p>	<p><b>E2-0070</b></p>
	<p><b>End Dam</b> For Sill Flashing E9-0617</p>	<p><b>E1-1050</b></p>			

FASTENERS

	<p><b>#10 x 1/4" FHMS</b>, Zinc Plated Steel, For attachment of Threshold Clip E1-1055 and BE9-0681 to BE9-0655</p>	<p><b>FM-1004</b></p>		<p><b>#12 x 1-1/4" PHSMS</b> Type "AB", Zinc Plated Steel, For Standard Framing Screw Spline attachment</p>	<p><b>PC-1220</b></p>
	<p><b>#10 x 1/2" FHSMS</b> Zinc Plated Steel, For attachment of Threshold Trim</p>	<p><b>FC-1008</b></p>		<p><b>#14 x 1/2" PHSMS</b> Type "AB", Zinc Plated Steel, For Threshold Gutter attachment</p>	<p><b>PC-1408</b></p>
	<p><b>#12 x 3/4" UFHSMS Type A</b>, Zinc Plated Steel, For End Dam Attachment</p>	<p><b>UA-1212</b></p>		<p><b>#14 x 1-1/2" PHSMS</b> Type "AB", Zinc Plated Steel, For Sill Gutter Attachment</p>	<p><b>PC-1424</b></p>
	<p><b>#10 x 5/8" PHSMS</b> Type "B", Zinc Plated Steel For attachment of Transom Glazing Pocket Filler</p>	<p><b>PB-1010</b></p>		<p><b>1/4" - 20 x 3/4" HWHMS</b> Type "F", Zinc Plated Steel For attachment of Steel Reinforcing to Verticals</p>	<p><b>HF-2512 -W1</b></p>
	<p><b>#12 x 1" PHSMS</b> Type "AB", Zinc Plated Steel, For Door Framing Screw Spline attachment</p>	<p><b>PC-1216</b></p>			

## FRAME FABRICATION

### STEP 1 DETERMINE FRAME SIZE

#### Determine Frame Width:

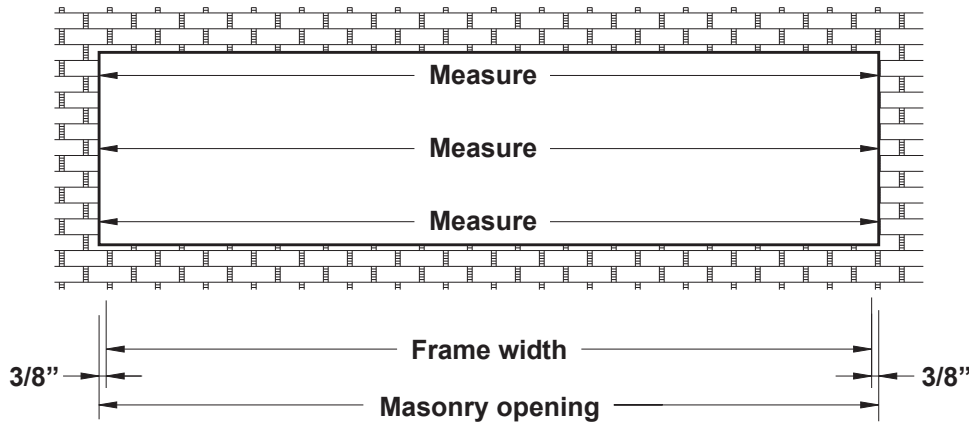

**Note:** Check the opening for squareness and plumb at both ends; unit must be installed in a true rectangle.

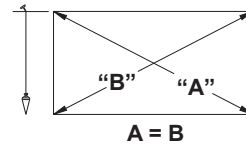

**Detail 1**

- Measure the width of the masonry opening at the top, middle and bottom.
- Select the smallest dimension measured and subtract 3/4" to determine the frame width size to be used.

See **Detail 1**.

**NOTE:** Frame widths over 24'-0" require expansion mullions every 12 to 15 feet (best location at vertical next to the door jamb.)

#### Determine Frame Height:

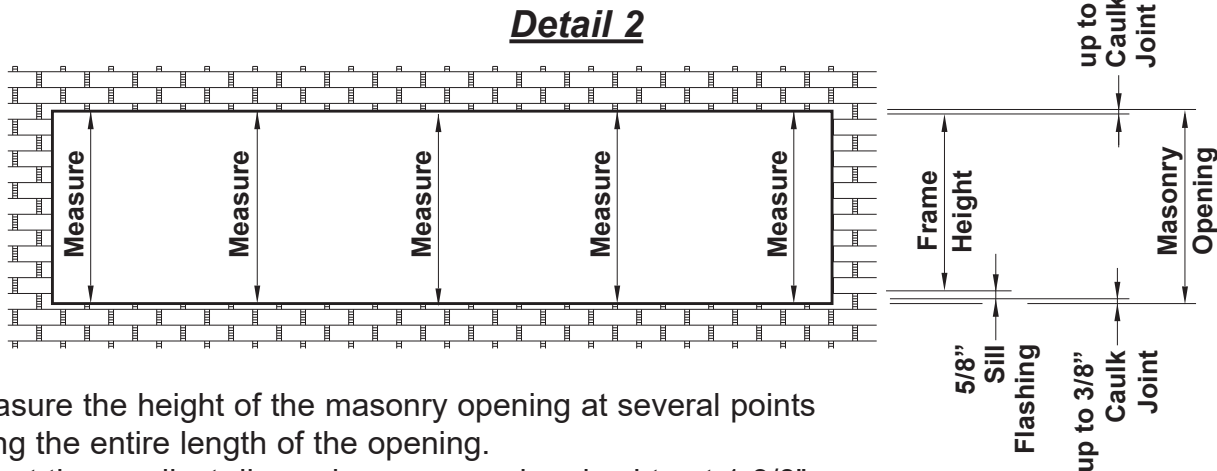

- Measure the height of the masonry opening at several points along the entire length of the opening.
- Select the smallest dimension measured and subtract 1-3/8" to determine the frame height:

up to 3/8" for the caulk joint at the head.

5/8" for the sill flashing BE9-0687.

up to 3/8" for the caulk joint under the sill flashing (excluding FPA-HVHZ applications).

See **Detail 2**.

**Note:** Refer to current FPA-HVHZ for anchoring guidelines.



FRAME FABRICATION

STEP 2  
FABRICATE SILL FLASHING

- Cut sill flashing, BE9-0687, to the masonry opening width dimension determined in Step 1 plus(+) 3/16. When using air tight threshold, E9-0487, sill flashing terminates at the door jamb.
  - For openings longer than 24'-0", the sill flashing must be spliced every twelve to fifteen feet. Allow a 3/8" splice joint between members; see **Detail 19 on Page 15**. Splice is to be located at the center of the daylight opening between verticals.
  - Locate and mark the centerline of each vertical on the sill flashing.
- See **Detail 3**.

Entrance Door with Water Resistant Threshold, E9-0502

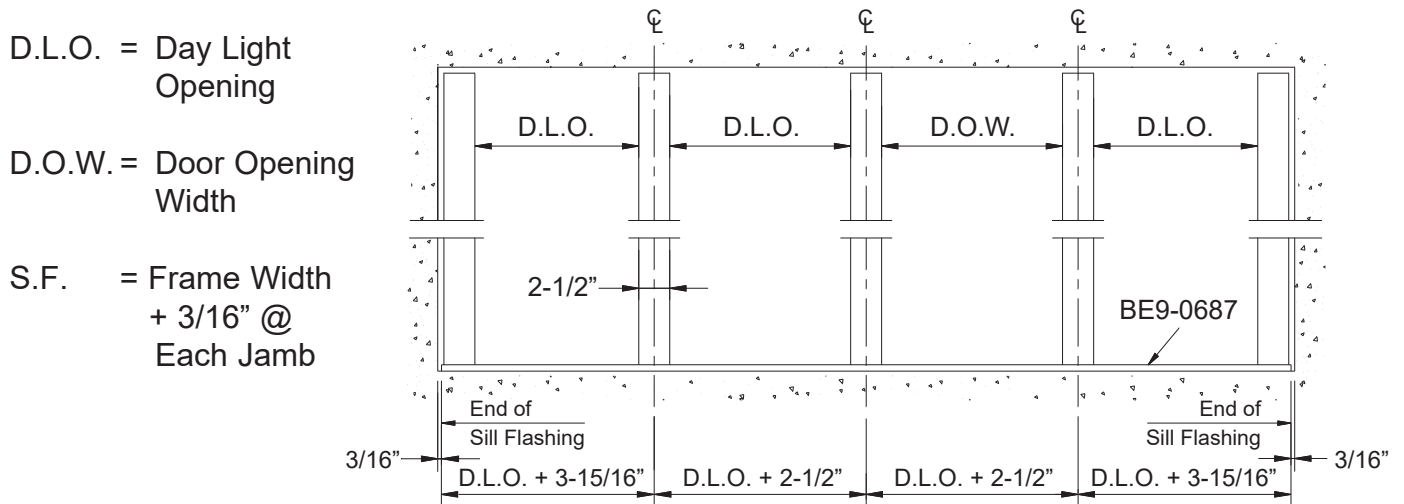

**Detail 3**

Entrance Door with Air Tight Threshold, E9-0487

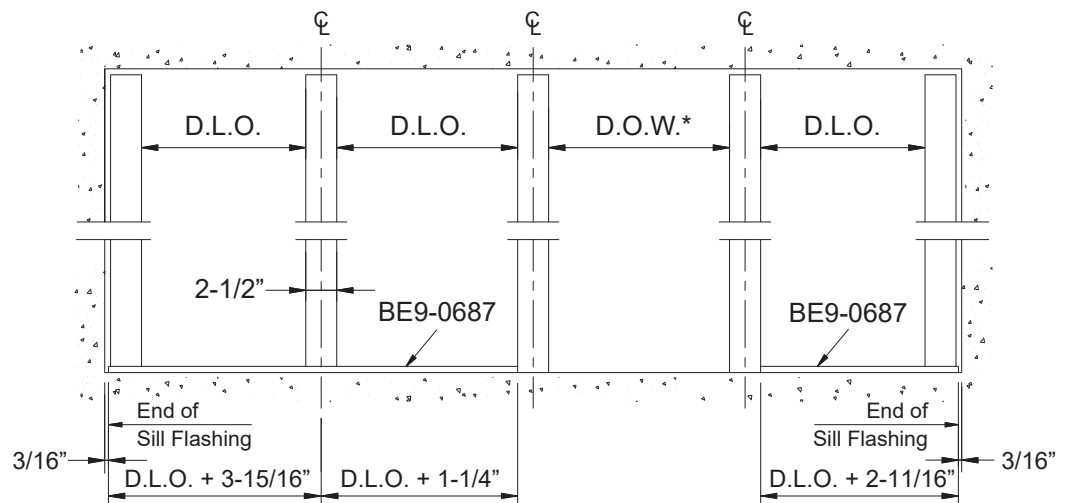

**\*Note:** The sill flashing, BE9-0687, does not run underneath the door frame when the air tight threshold, E9-0487, is used.

**FRAME FABRICATION**

**STEP 2  
FABRICATE SILL FLASHING (Continued)**

- Locate and drill clearance holes in sill flashing for perimeter anchors. Hole quantities, size, and location will vary per design requirements. Refer to the recommended anchoring shown on **Page 19**, approved shop drawings, or Florida Product Approvals for appropriate anchor fastener locations, or consult a qualified engineer or YKK AP.
- Drill 5/16" dia. clearance holes for 1/4" fasteners or 3/8" dia. clearance holes for 5/16" fasteners. See **Detail 4** for anchor hole locations.

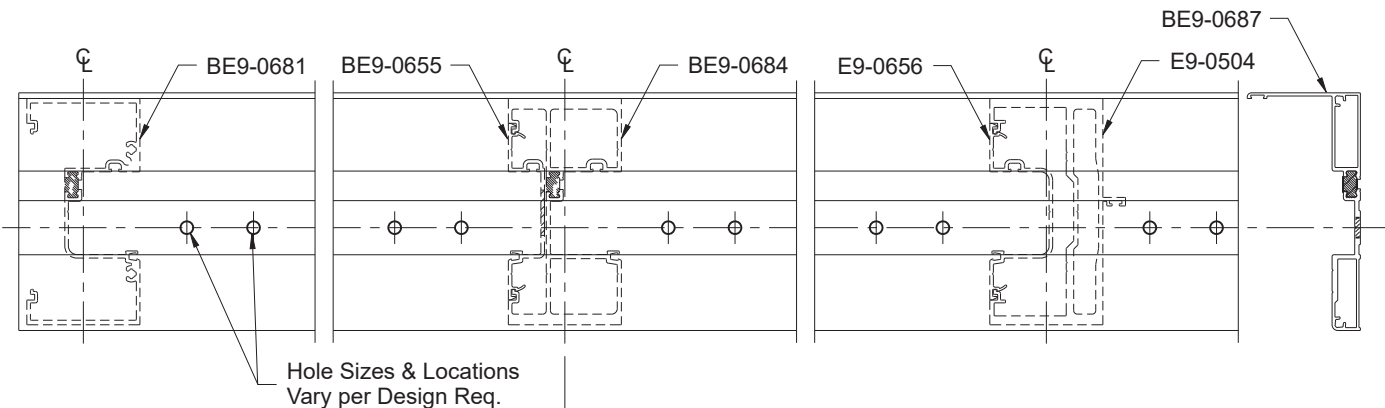

**Detail 4**

Fabricate weep holes in the sill flashing:

- Measure 8" in each direction of the vertical centerline and mark on the front face of the sill flashing the location for the weep holes.
- Drill a 3/8" (#V) diameter hole through both walls of the hollow in the sill flashing at each location marked.

See **Detail 5**.

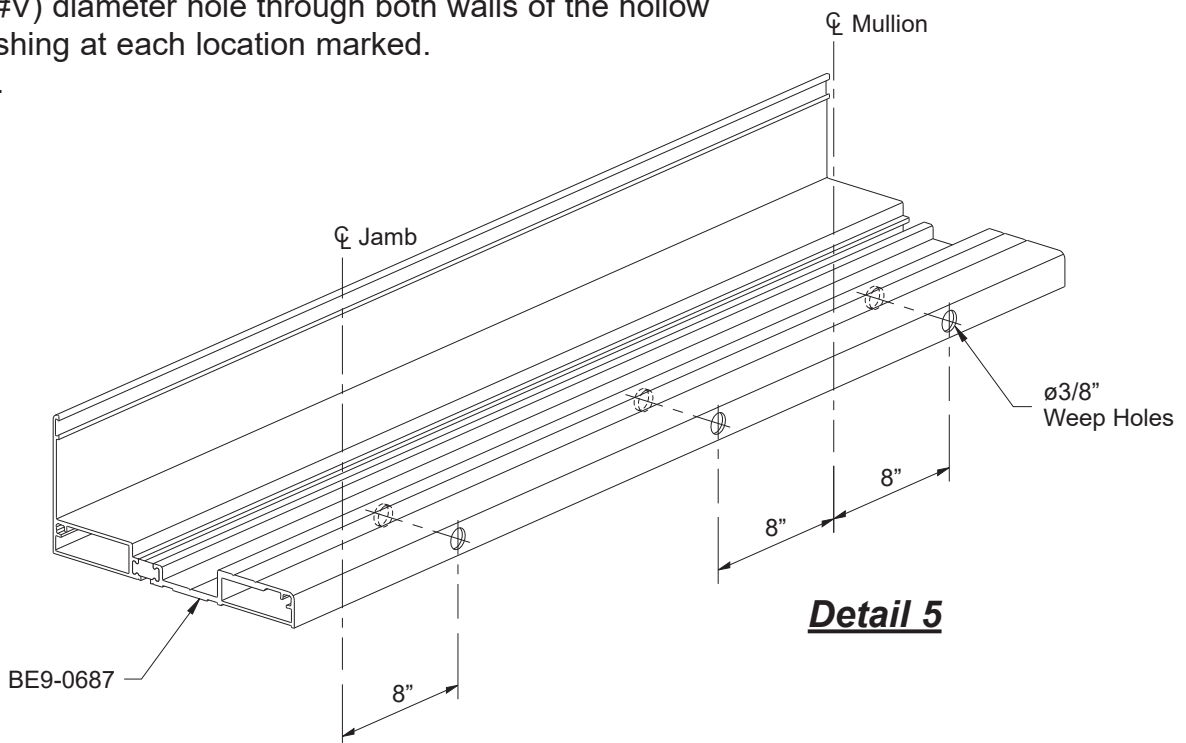

**Detail 5**

FRAME FABRICATION

STEP 2  
FABRICATE SILL FLASHING (Continued)

Where the air-tight door threshold is utilized, the BE9-0687 sill flashing terminates at the door jambs as shown in **Detail 6**.

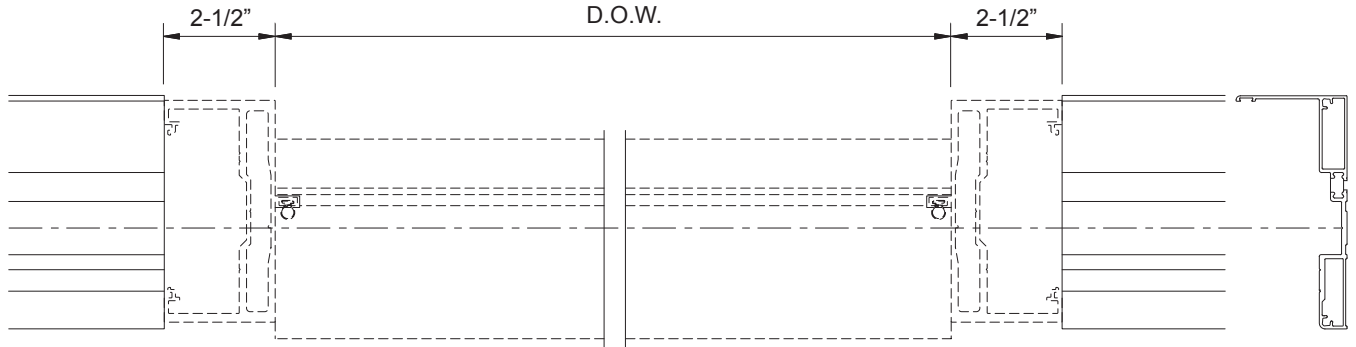

**Detail 6**

When the water-resistant threshold is used, the BE9-0687 sill flashing is notched as shown on **Detail 6A**. Also, drill 3/8" diameter weep holes through both walls of the front hollow of the sill flashing as shown.

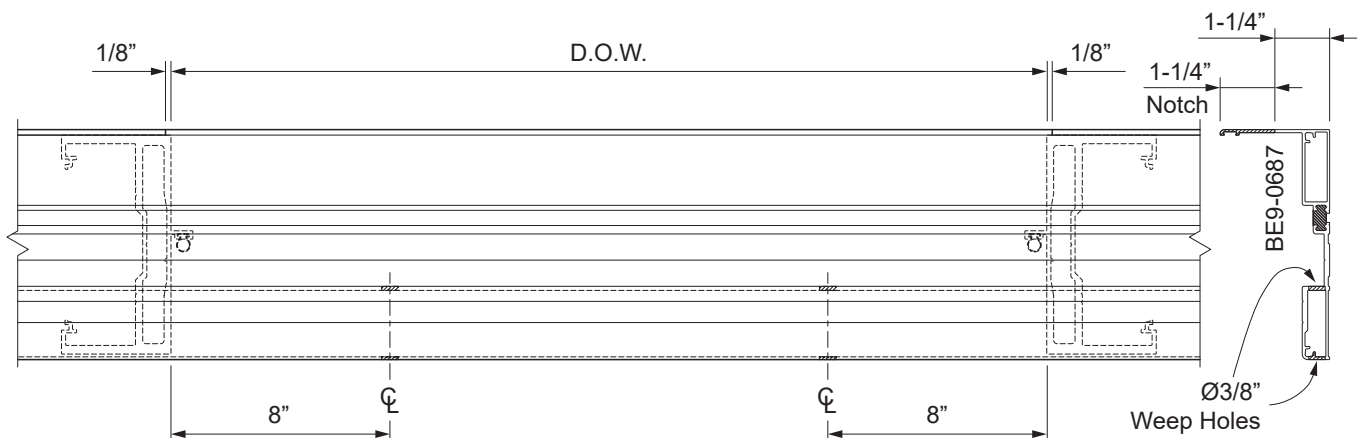

**Detail 6A**

## FRAME FABRICATION

### STEP 3

### FABRICATE VERTICAL MULLIONS AND POCKET FILLERS

-Cut all vertical members and pocket fillers to the frame height determined in **Step 1**.

Prepare verticals and pocket fillers for attachment of horizontal members and anchor fillers:

-Using a short piece of each horizontal member as a template, center horizontal members on the face of verticals and mark each hole location.

-Hole locations may also be determined by laying out locations along the face of verticals as shown below in **Detail 7** (or in **Detail 8** for Inside Glazing.)

-Drill 0.236" diameter (#B drill bit) holes at each location marked.

**Note:** For vertical members, BE9-0684 & E9-0504, drill through both the web and front face of the mullion. It is also necessary to turn the mullion over and drill 1/2" dia. holes through the mullion web only, centered on the first holes drilled, to allow the screw heads to pass through.

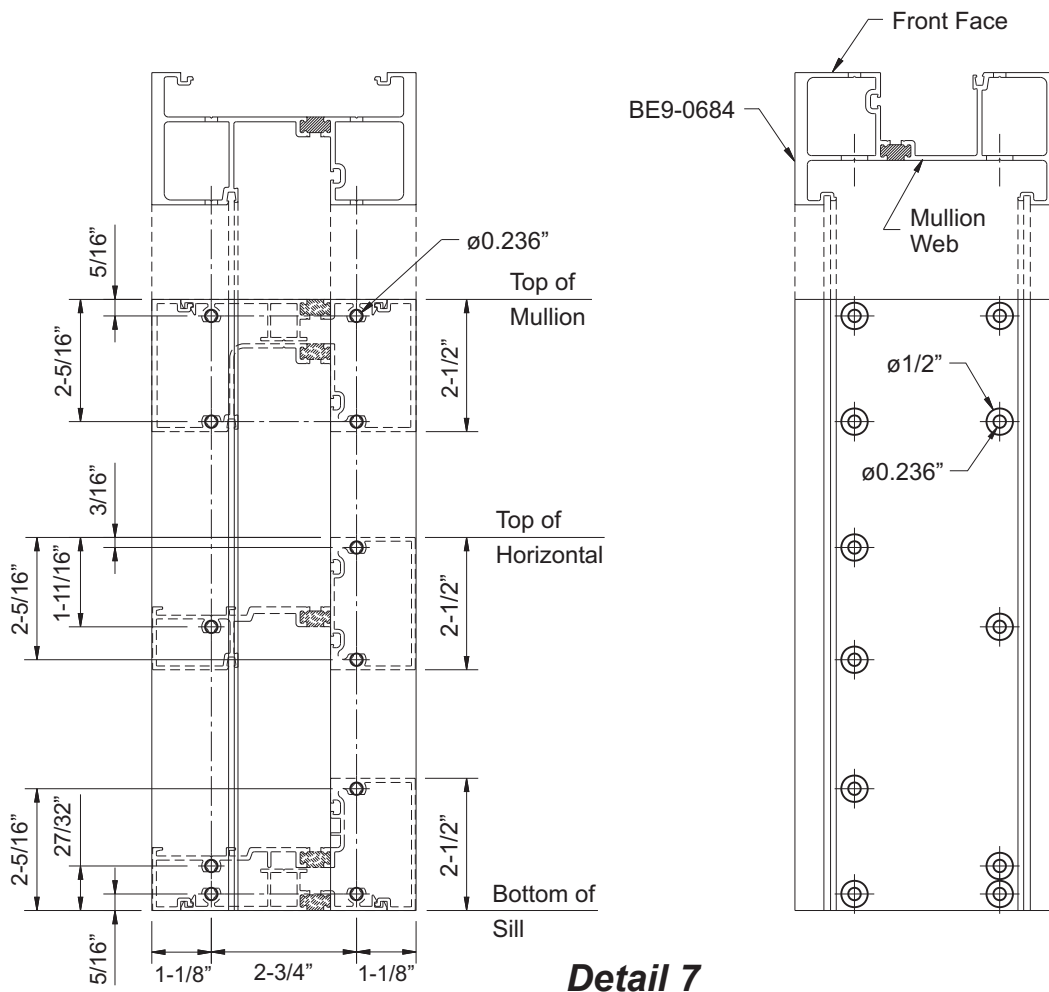

FRAME FABRICATION

STEP 3 (Continued)

FABRICATE VERTICAL MULLIONS AND POCKET FILLERS

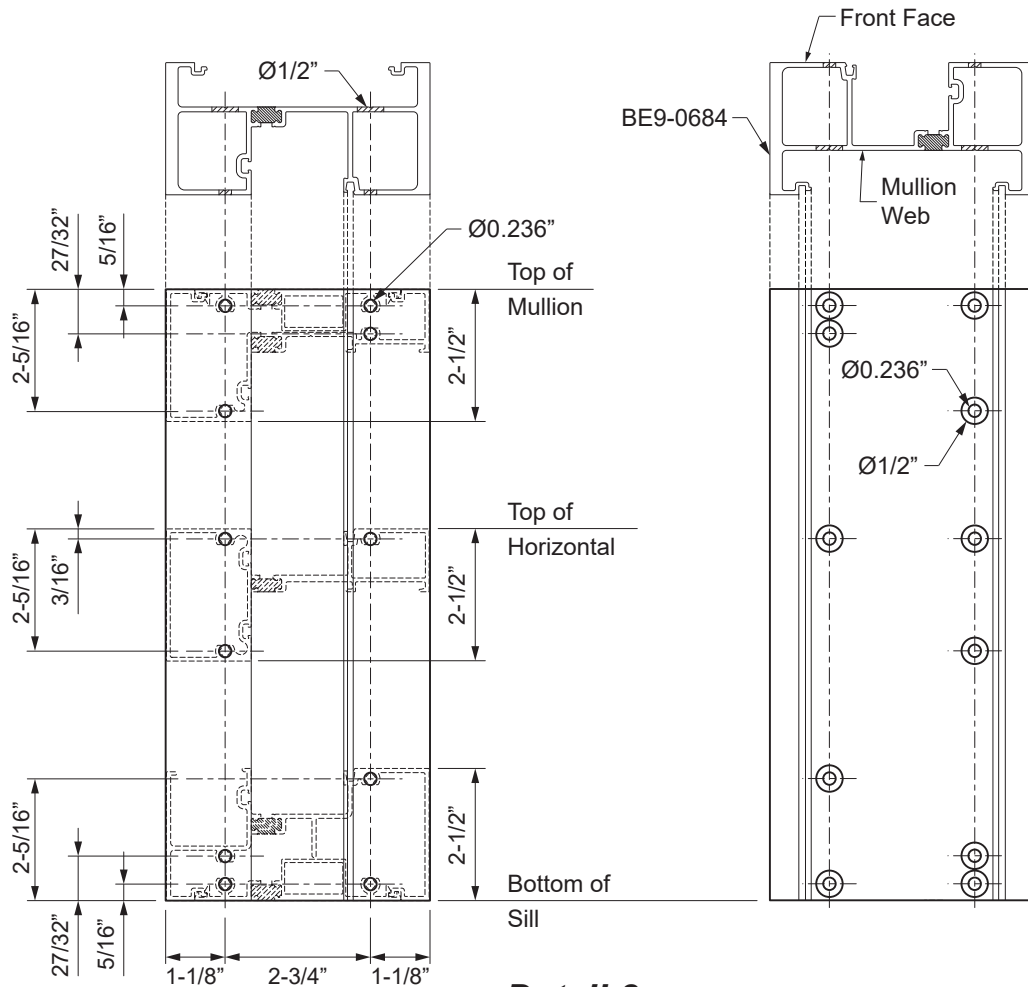

**Detail 8**  
Inside Glazing

**FRAME FABRICATION**

**STEP 3 (Continued)**

**FABRICATE VERTICAL MULLIONS AND POCKET FILLERS**

The vertical must be fastened to the pocket filler BE9-0655 with FM-1004 fasteners. Fabricate BE9-0655 as shown below.

- From each end of the pocket filler, locate the next available spot centered between the slots, and mark that location for a screw hole.
- Measure 10" on center thereafter (between every other slot) and mark the locations on the "V"-Groove.

**Note:** Hole locations on pocket fillers must match the ones on their respective vertical. Coordinate with the location of horizontals so that the horizontals do not block these holes.

- For verticals, drill 0.161" dia. (#20) holes at each location marked.
- For pocket fillers drill 0.213" dia. (#3) holes at each location marked and countersink for a #10. See **Detail 9**.

Do not attach the glazing pocket filler to the vertical at this time; they will be attached later.

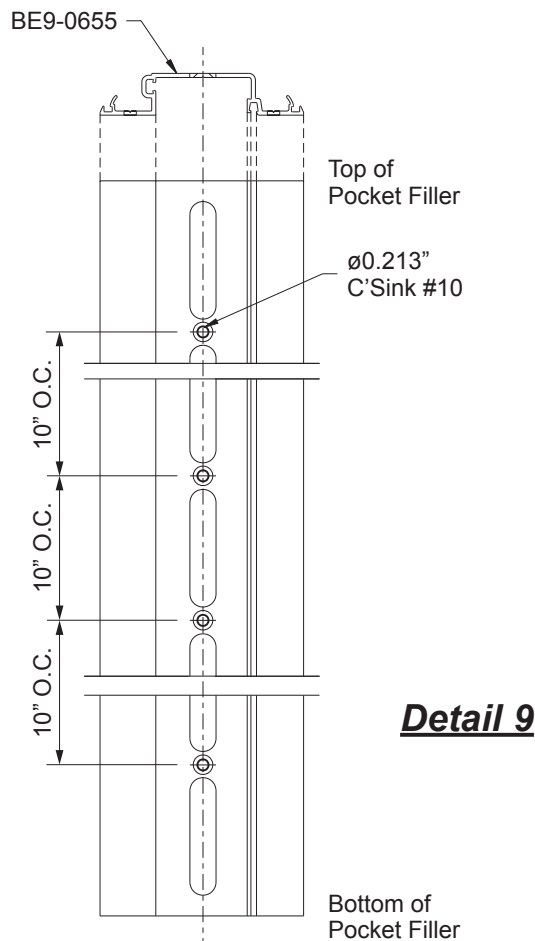

## FRAME FABRICATION

### STEP 4 FABRICATE HEAD, HORIZONTAL & SILL MEMBERS

-Cut head, horizontal and sill members to daylight opening between verticals.

Fabricate the ends of head members for anchor fasteners:  
-Drill and countersink head member, BE9-0681, for required fastener (flat head fasteners only).

-Install anchor filler, E1-1060, at each end of the head member and crimp the snap legs at the ends to hold it in place.

-Match drill a clearance hole through anchor fillers, E1-1060, at each anchor location for appropriate fastener.

See **Detail 10**.

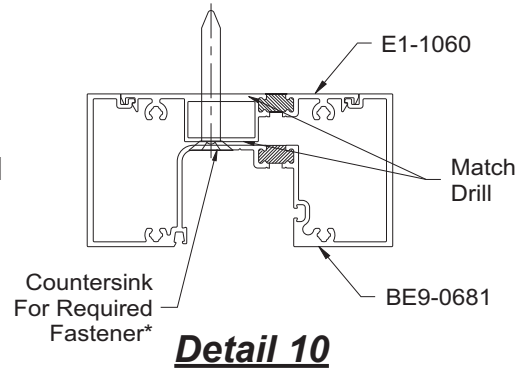

\* Refer to the recommended anchoring shown on **Page 19**, approved shop drawings, or Florida Product Approvals for appropriate anchor fastener locations, or consult a qualified engineer or YKK AP.

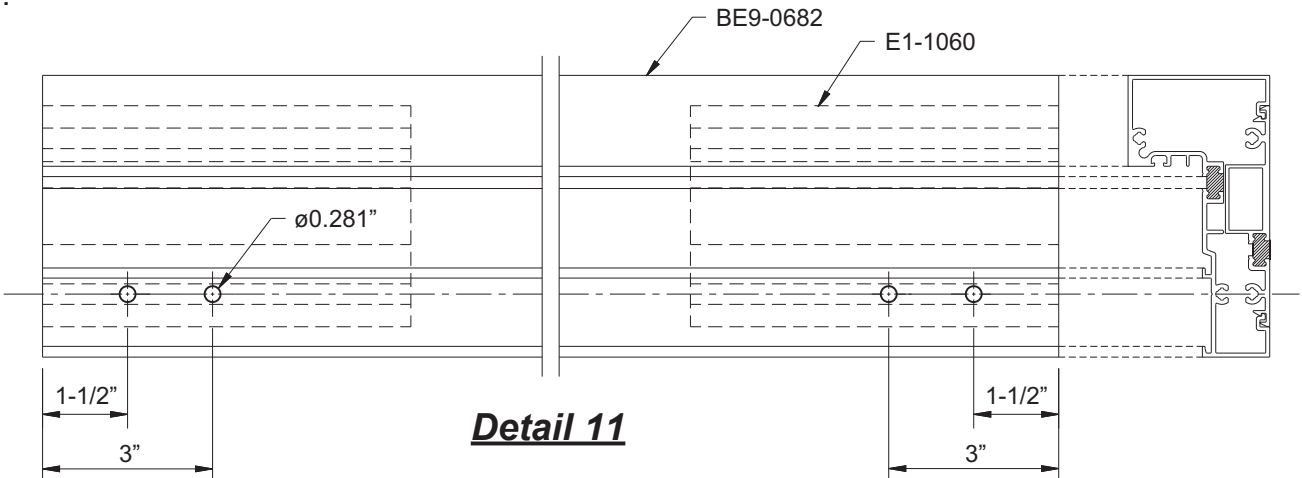

Fabricate sill member for sill gutter anchors:

-Measure in 1-1/2" and 3" from both ends of sill members and mark locations along "V"-Groove.

-Drill 0.281" dia. (#K) holes at each location marked for sill gutter anchor fasteners, PC-1424.

-Install anchor filler, E1-1060, at each end of the sill member and crimp the snap legs at the ends to hold it in place.

-Match drill 0.281" dia. (#K) holes through anchor fillers, E1-1060, at each anchor location.

See **Detail 11**.

### STEP 5 FABRICATE GLASS STOPS

-Cut glass stops to daylight opening between verticals minus(-) 1/32".

## FRAME ASSEMBLY

### STEP 6 INSTALL STRUCTURAL SILICONE SPACERS (For Large Missile Impact Applications Only)

- Install all structural silicone spacers, E2-0084, in all horizontals and verticals **prior** to frame assembly.
- Horizontal silicone spacers are to be cut to D.L.O. plus(+) 7/8" and must be notched as shown in **Detail 12**.
- Vertical silicone spacers are to be cut to the full length of the vertical mullion and are not notched.

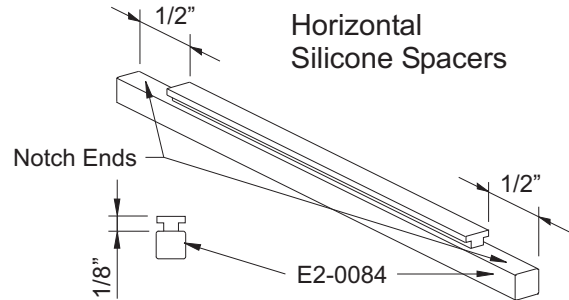

**Detail 12**

**Caution:** Be careful not to stretch silicone spacers when installing.

### STEP 7 ASSEMBLE FRAMES

- Clean all joints with isopropyl alcohol (50%) and wipe clean with white lint free cotton cloth using the two cloth method.
- Apply sealant to each end of head, horizontal and sill members prior to attaching to vertical.
- Attach head, horizontal, sill members and anchor fillers, E1-1060 to verticals and pocket fillers with PC-1220 fasteners.
- Tool all sealant to ensure a water tight joint.

See **Details 13, 14, & 15**.

**Detail 13**

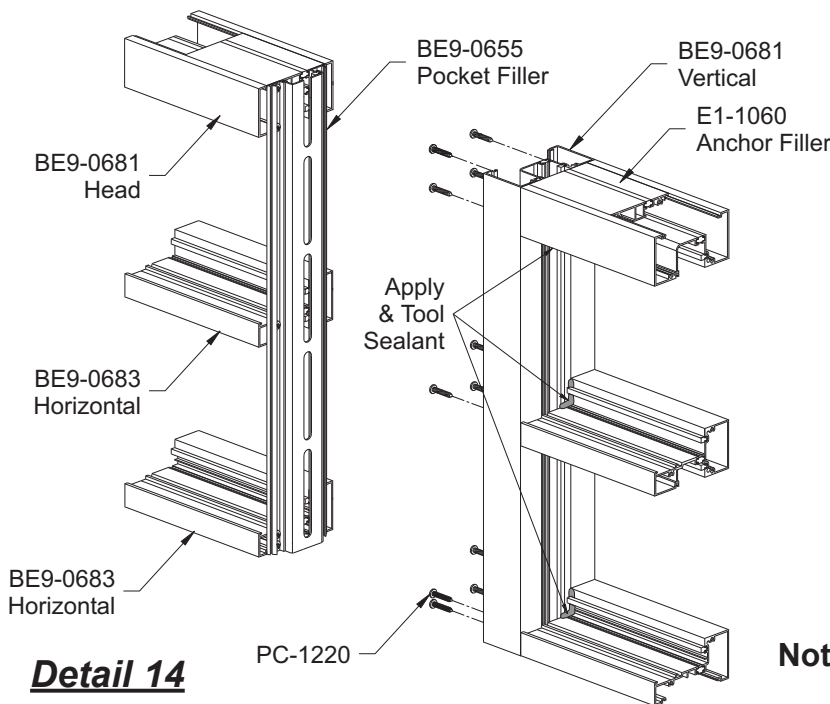
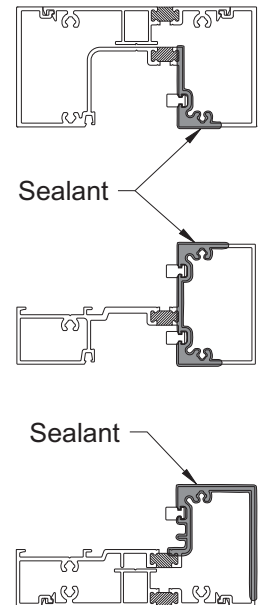

**Detail 14**

**Note:** In all metal to metal applications use approved sealants only.



## FRAME ASSEMBLY

### STEP 7 (Continued) ASSEMBLE FRAMES

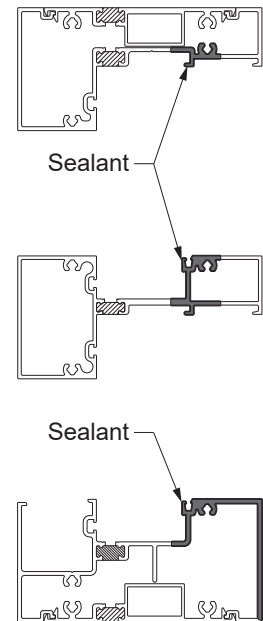
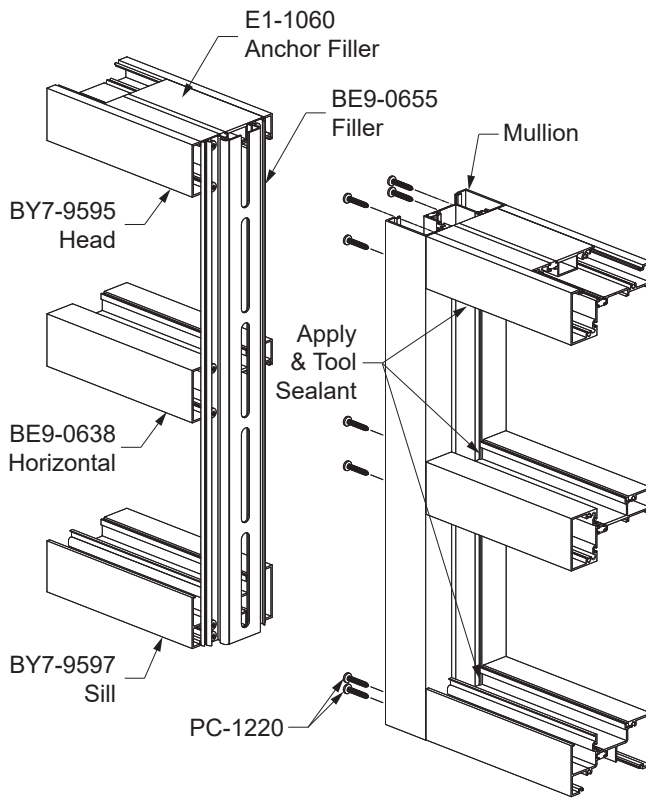

***Detail 15***  
Inside Glazing

**FRAME ASSEMBLY**

**STEP 8  
INSTALL SILL FLASHING END DAMS**

- Hold the end dam with one hand and grab the tab with a pair of pliers.
- Bend the end dam tab left or right 90 degrees in the proper direction.

See **Detail 16**.

**Note:** The end dam tab must be bent in the correct position for the left or right end of the sill flashing.

- Clean all joint surfaces using Isopropyl Alcohol.
- Insert backer rod into the front cavity of the sill flashing. Fill the cavity flush with silicone sealant as shown in **Detail 17**.

- Apply sealant to the end of sill flashing.
- Slide the tab into the top portion of the sill flashing.
- Tap the tab into place with a small tool until the end dam is snug against the end cut of the flashing.
- Fasten the end dam to the sill flashing with two UA-1212 screws, starting at the back, followed by the front.

- Tool sealant along the joint between the end dam and the sill flashing as shown in **Detail 18**.
- Seal over any exposed screw threads.

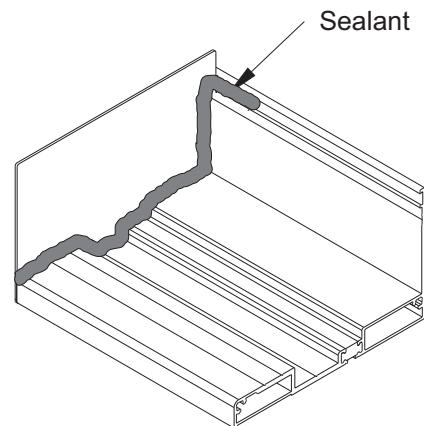
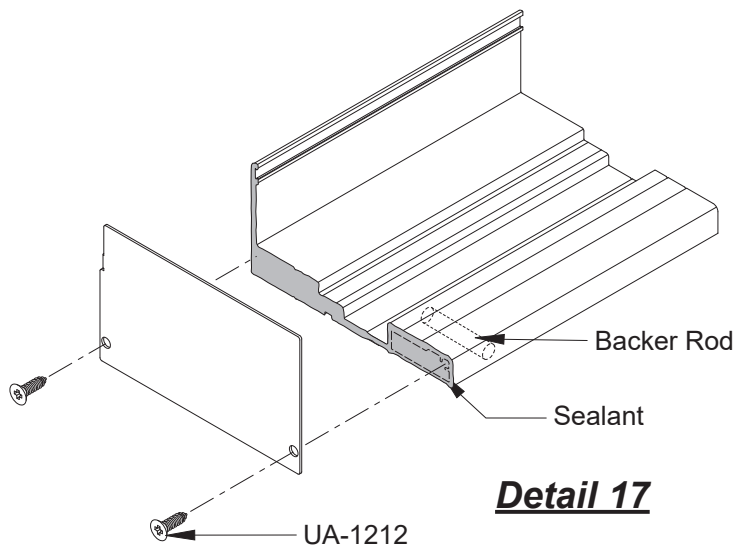
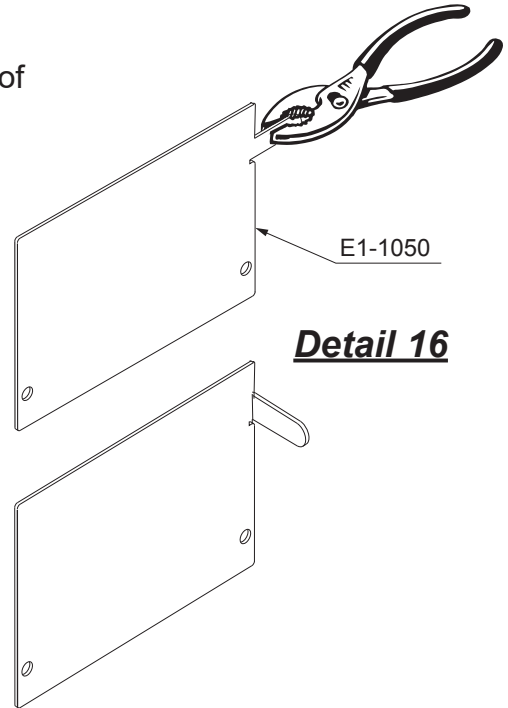

## FRAME INSTALLATION

### STEP 9 INSTALL SILL FLASHING

- Starting at the smallest opening height, install the sill flashing with a minimum of 3/8" shim underneath. Sill flashing must be installed level.
- Anchor the sill flashing to the structure a maximum of 4" from each end and then 18" to 24" on center.
- Apply and tool sealant to cover the heads of all fasteners.

### STEP 10 INSTALL SILL FLASHING SPLICE SLEEVE

- After the sill flashing has been shimmed and installed to the building structure, apply a small backer rod under the sill flashing and inside the front cavities of the sill flashing as shown in **Detail 19**.
- Position the silicone splice sleeve against the back wall below the groove.
- Bend the silicone splice sleeve into the front on the channel as shown. Mark and cut the sleeve at this position.
- Clean the sill flashing and silicone splice sleeve with isopropyl alcohol at the splice location.
- Seal the flashing at the splice location as shown in **Detail 19**, before positioning the flashing. Fill the two front cavities with silicone sealant prior to setting the silicone splice sleeve onto the silicone.
- Tool sealant tight as shown in **Detail 20**, squeezing the sheet flat.
- Thoroughly seal the small joint directly in front of the silicone splice sleeve as shown in **Detail 20**.

When using E2-0070, a compatible silicone sealant must be used at the splice. Compatible silicone sealants include Tremco Spectrum 2 and Dow Corning 795.

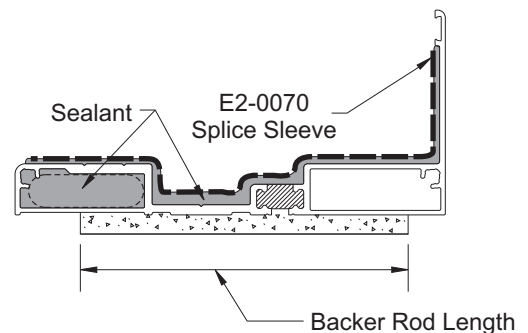
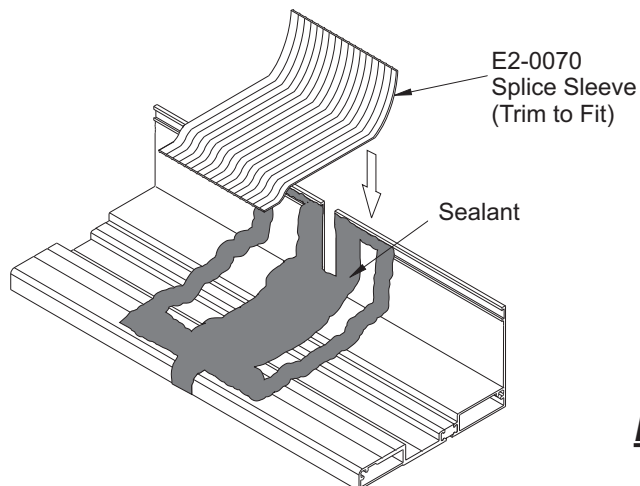

***Detail 19***

**FRAME INSTALLATION**

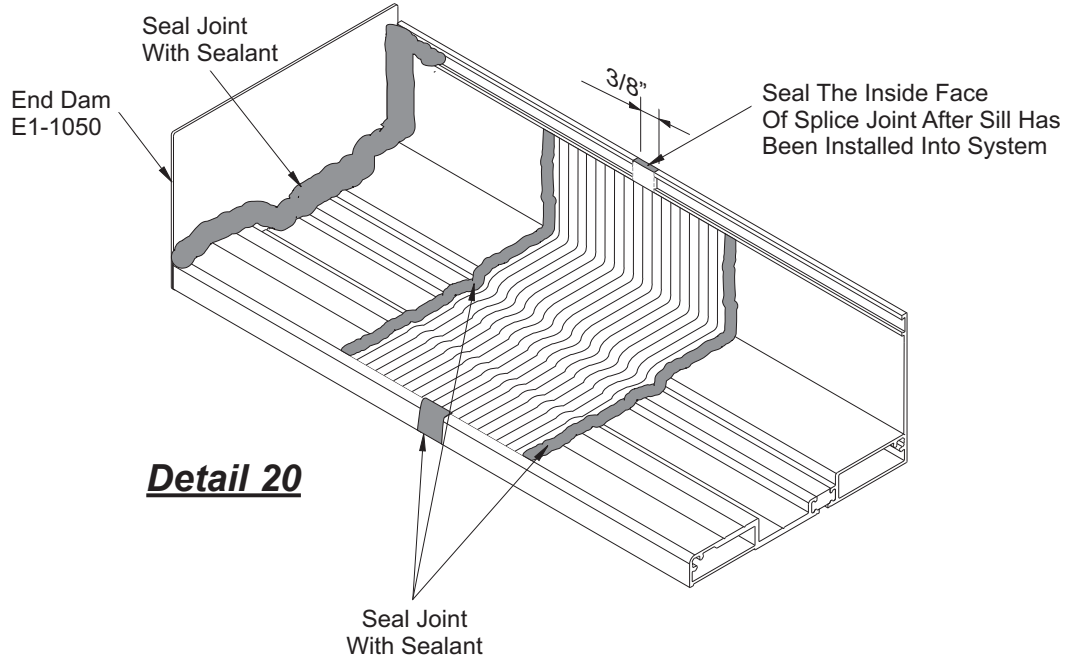

**STEP 11  
SILL PREPARATION**

At every splice condition, apply bond breaker tape to the back of the sill member before it is placed into the sill flashing.

See **Detail 21**.

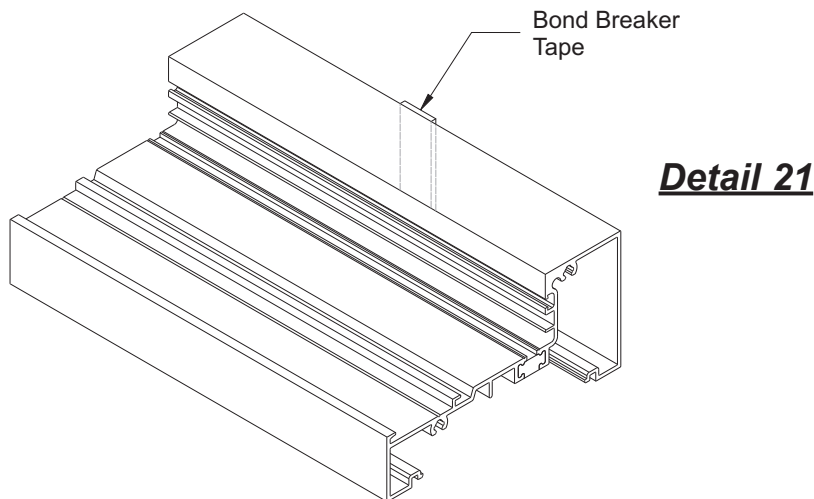

## FRAME INSTALLATION

### STEP 12 INSTALL SILL FLASHING AT CORNERS

- Cut two 12" long pieces of sill flashing and miter (45° for 90° corners and 67.5° for 135° corners.)
- Align the two pieces at the corner condition with the mitered ends pushed together tight and anchor the sill flashing as indicated on approved shop drawings.
- Apply and tool sealant to the mitered joint and anchor heads.

See **Detail 22**.

- Continue installing the rest of the sill flashing, providing a 3/8" expansion joint at splices shown in **Step 10** on **Page 15**.

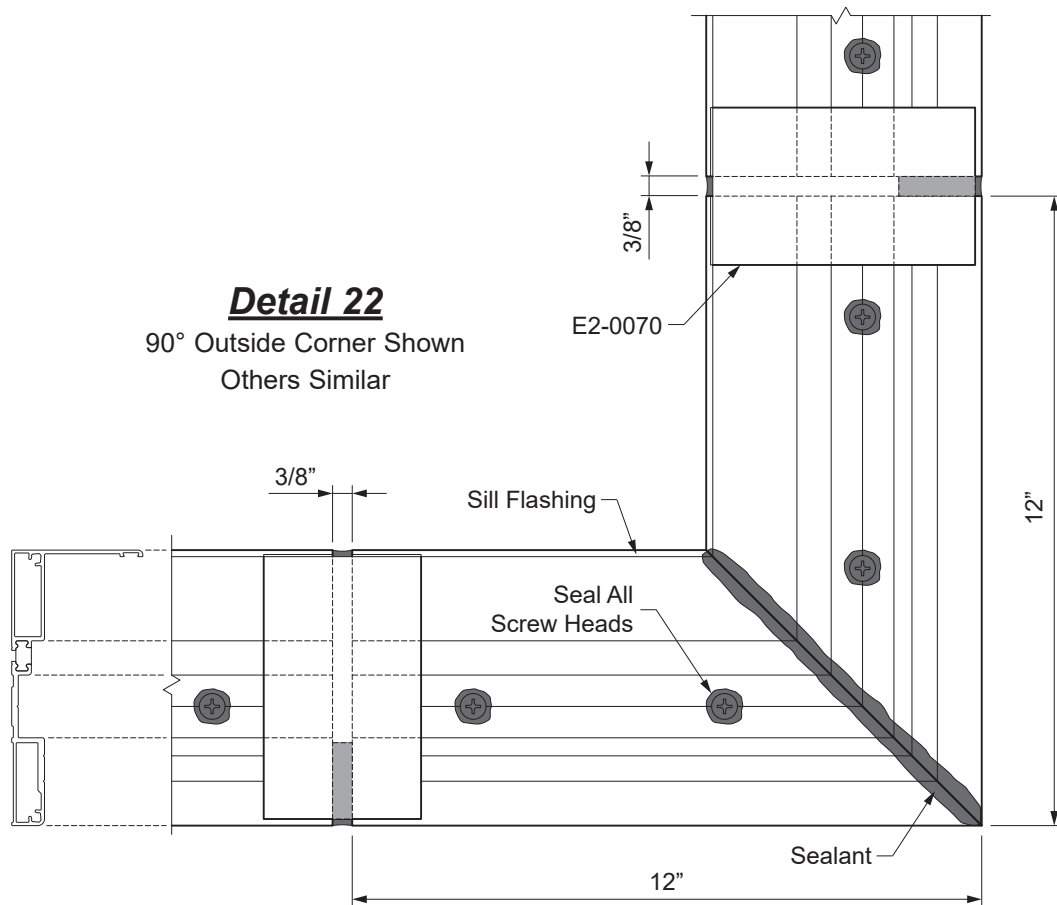

**FRAME INSTALLATION**

**STEP 13**

**PREPARE DOOR JAMBS (AIR THRESHOLD ONLY)**

-Prior to snapping the assembled frames into the door jamb, the end of the sill flashing needs to be sealed to the door jamb.

-Apply and tool sealant to all sill flashing to door jamb joints.

-Apply sealant to completely fill the door jamb cavity and ramp the sealant down onto the sill flashing.

See **Detail 23**.

Refer to the **35H/50H or 35HL/50HL Entrances Installation Manual** for door installation instructions.

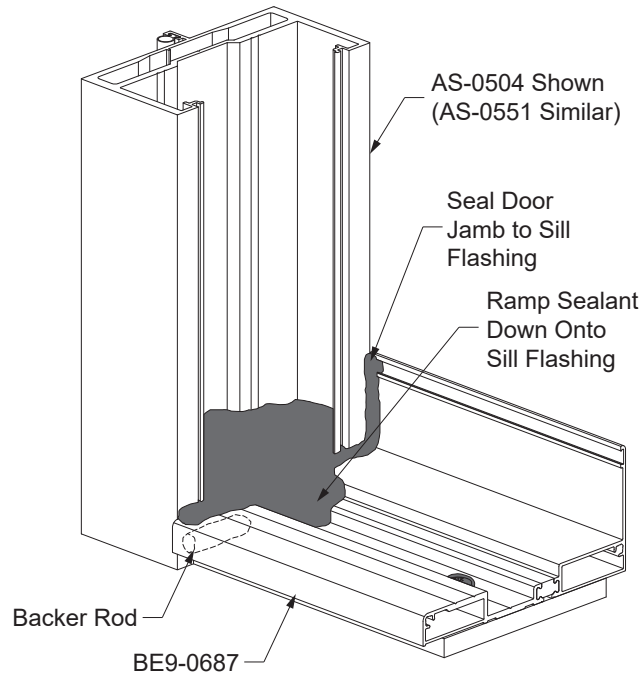

**Detail 23**

## FRAME INSTALLATION

### STEP 14 INSTALL STOREFRONT FRAMES

-Immediately before installing frames, apply sealant to face of back leg of sill flashing.

**Note: Only apply sealant to areas being installed so that sealant does not cure.**

See **Detail 24**.

-Snap the pocket filler framing portions to the vertical mullion framing portions to complete the frame.

-Match drill vertical and pocket filler.

**Warning: Mullions cannot be unsnapped once installed.**

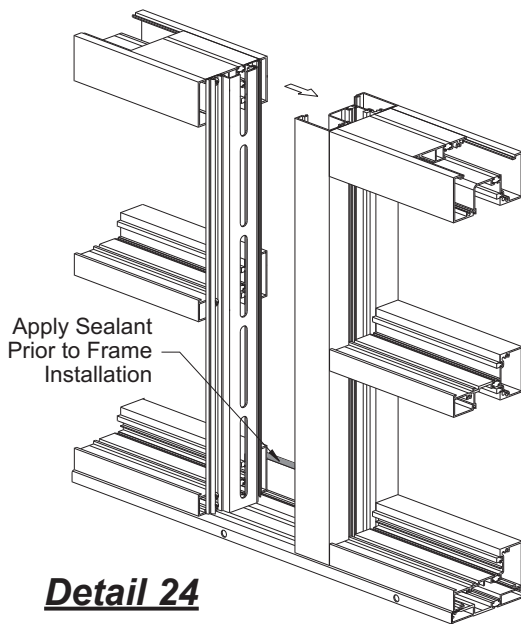

**Detail 24**

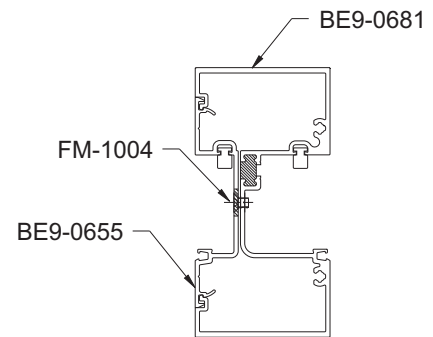

**Detail 25**

-Attach pocket filler, BE9-0655, to verticle with FM-1004 fasteners.

See **Detail 25**.

-Set frame into place on the sill flashing.

-Always shim at head anchor locations and jambs (3/8" nominal).

-Attach head members and jambs (if required) to the structure with the required flat head fasteners.

Anchor sill members to sill flashing:

-Match drill sill flashing for sill gutter anchors using holes already drilled in the sill members.

-Drill 0.201" diameter (#7 drill bit) holes and attach sill members using PC-1424 fasteners.

See **Detail 26**.

**Table 1 - Minimum Embedment into Structure**

Condition*	Minimum Embedment	
	Wood	Concrete
At Head	1-3/4"	1-1/4"
At Sill Flashing	1-3/4"	1-1/4"

\* Structure must be capable of resisting all loads imposed by fasteners and anchors.

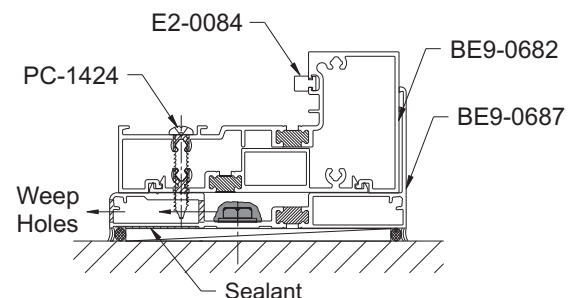

**Detail 26**

## FRAME INSTALLATION

### STEP 14 (Continued) INSTALL STOREFRONT FRAMES

#### Recommended Anchoring As Tested:

- The door frame must be installed plumb, square, level and true.
- Shim as required (3/8" caulk joint at head and jambs).
- Anchor the frame to the structure according to **Detail 27** and **Detail 28** or refer approved shop drawings:

- △ = Sill Flashing Anchor:
  - Concrete: 5/16" x 2" HH Tapcon masonry fastener
  - Wood: 5/16" x 3" HH Tapcon masonry fastener
- ▼ = Head Anchor:
  - Concrete: 5/16" x 3" FPH Tapcon masonry fastener
  - Wood: 5/16" x 3" FPH Tapcon masonry fastener
- = Sill Gutter Anchor:
  - #14 x 1-1/2" PHSMS Type AB
- = Jamb Condition:
  - No anchor for frames 9'-0" and under up to 70 psf.
  - Contact YKK AP for frames over 9'-0" or for design loads greater than 70 psf.

Refer to FPA Drawings for locations and other substrates.

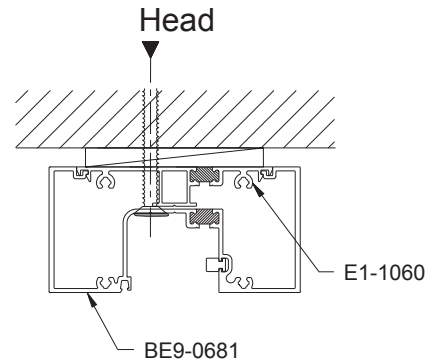

**Detail 27**

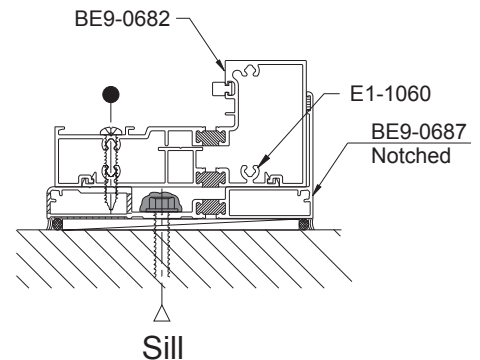

**Table 1 - Minimum Embedment into Structure**

Condition*	Minimum Embedment	
	Wood	Concrete
At Head	1-3/4	1-1/4
At Sill Flashing	1-3/4	1-1/4

\* Structure must be capable of resisting all loads imposed by fasteners and anchors.



## FRAME INSTALLATION

### STEP 14 (Continued) INSTALL STOREFRONT FRAMES

**Note:** \*Additional anchors when required depending on wind load.  
See engineering calculations and/or FPA-HVHZ.

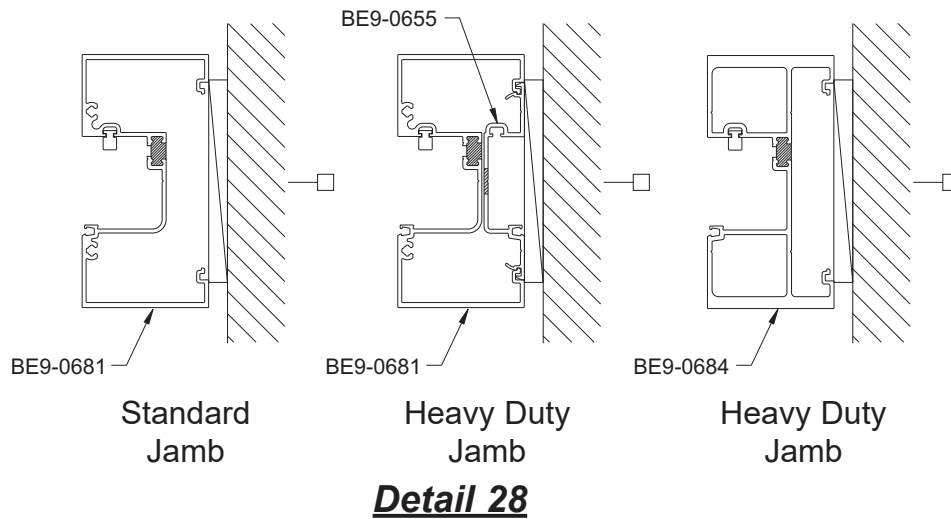

**FRAME INSTALLATION**

**STEP 15  
INSTALL WATER DEFLECTORS**

YHS 50 TU requires the installation of a water deflector, E2-0049, at the ends of every intermediate horizontal to keep water off of the insulated units. For best adhesion, make sure that the horizontal is clean and dry.

-Peel away the protective paper from the bottom of the water deflector, E2-0049, and install the water deflector at the ends of each horizontal. Position the vertical leg of the water deflector against the end of the horizontal. See **Detail 29**.

**Note:** For Wet Glazing applications, it may be necessary to notch ramp of the water deflector around the vertical spacer. Ensure the water deflector is sealed to the spacer.

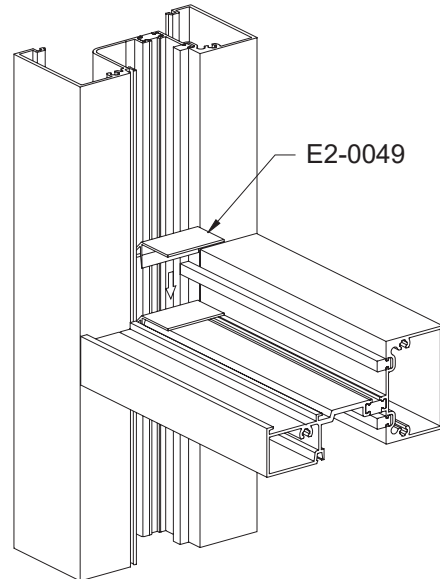

**Detail 29**

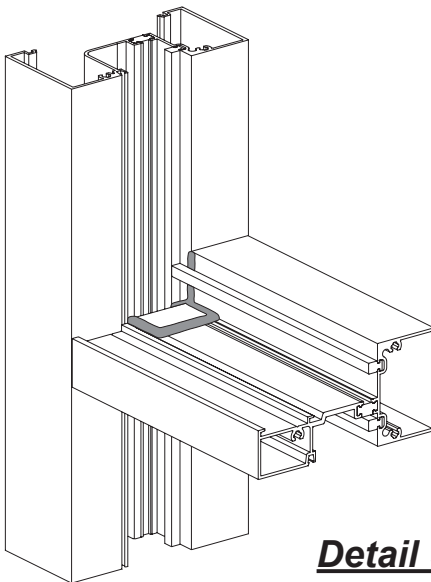

**Detail 30**

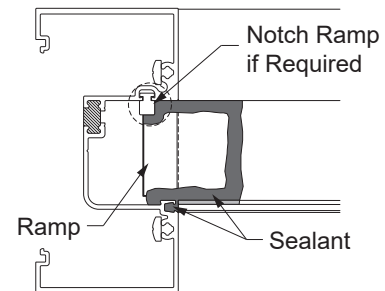

**Detail 31**

-Apply and tool sealant along the edges of the water deflector and down onto the horizontal. See **Detail 30**.

-Seal the ramp of the water deflector to the interior side of the glazing pocket. Tool sealant into vertical reglet. See **Detail 31**.

## FRAME INSTALLATION

### STEP 16 PERIMETER SEALANT

- Position backer rod around perimeter of frame.
- Apply sealant to the joint between frame and masonry (approved sealant only).
- Make sure all screw heads are sealed.

See **Detail 32**.

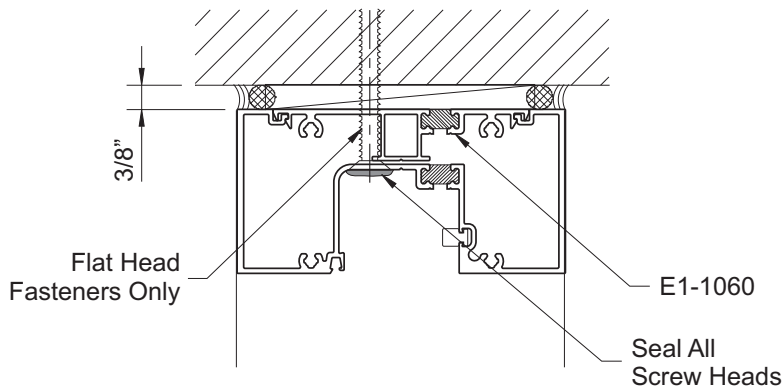

***Detail 32***

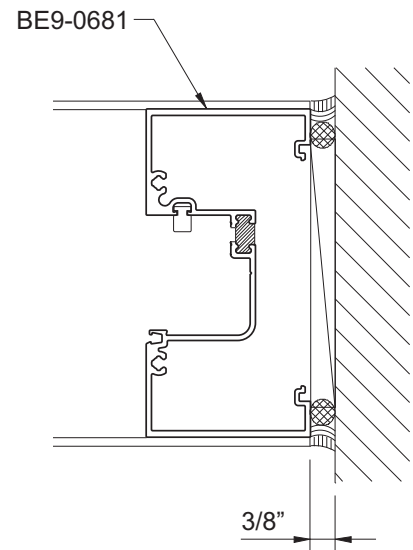

## GLAZING

### STEP 17 DETERMINE GLASS SIZE

Typical Framing:     **Glass Width = Daylight Opening plus(+) 1-1/8"**  
                               **Glass Height = Daylight Opening plus(+) 1-1/8"**

### GLAZING: DRY GLAZING APPLICATIONS ONLY

- Cut horizontal & glazing gaskets, E2-0088, to daylight opening plus(+) 3/16" for each foot of length.
- Cut vertical interior glazing gaskets, E2-0088, to daylight opening plus(+) 1-1/4" plus(+) 3/16" for each foot of length.
- Using a small brush clean out any dirt that may have accumulated in the gasket reglets.
- Install the vertical gaskets first. Install the ends and middle of the gasket first; push in the remainder of gasket working from the middle towards the ends.
- Install the horizontal glazing gaskets next. Apply sealant to the gasket ends to seal horizontal gasket to the vertical gasket.
- Tool the excess sealant at the gasket corners to ensure a watertight seal.

See **Detail 33**.

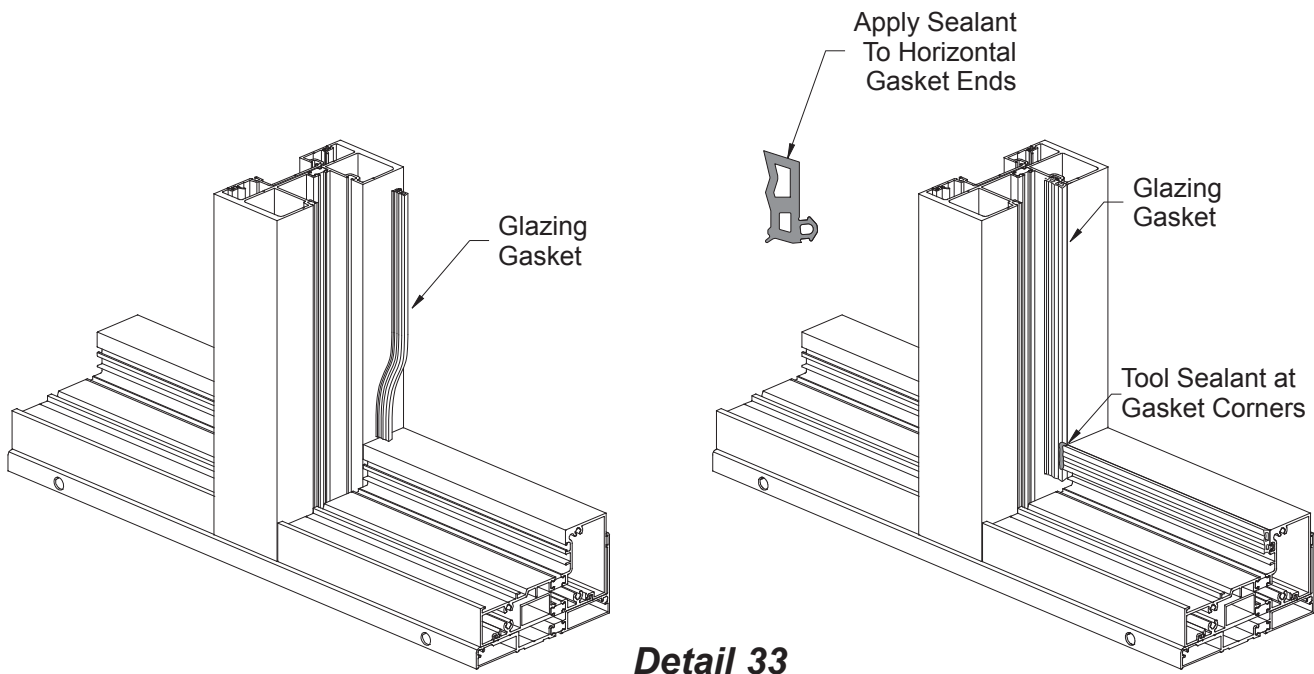

**Detail 33**

## GLAZING

### STEP 18 GLAZING

- Install side blocks, E2-0096, centered along the vertical opening of the shallow pocket.
- Cut horizontal & vertical exterior gaskets to daylight opening plus(+) 1/4" for each foot of length.
- Clean all glazing surfaces and joints of foreign matter and contaminants such as grease, oil, dust, frost, and surface dirt. **Do not** use water or soap solutions to clean surfaces or tool sealant.

See **Detail 34 & 34A.**

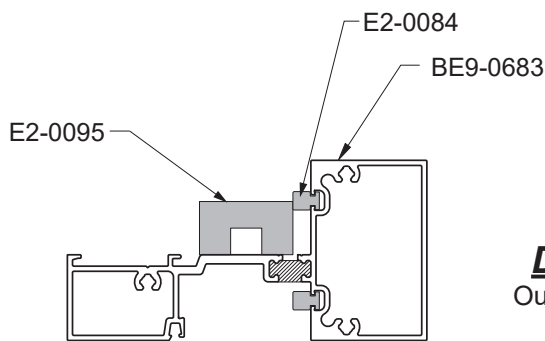

**Detail 34**  
Outside Glazing

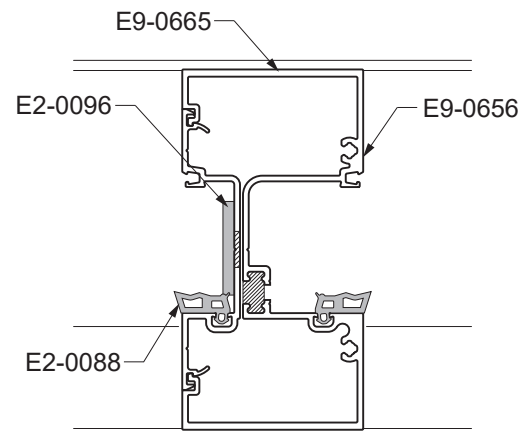
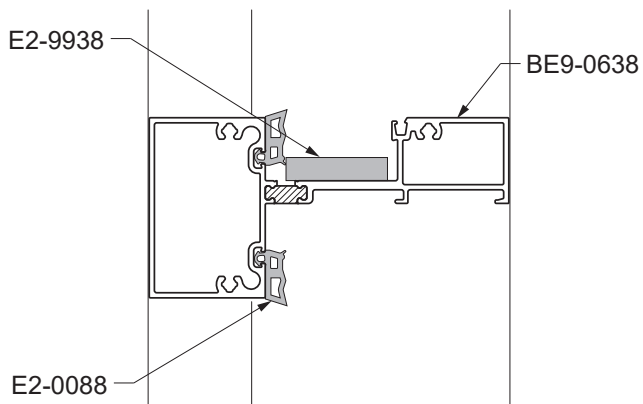
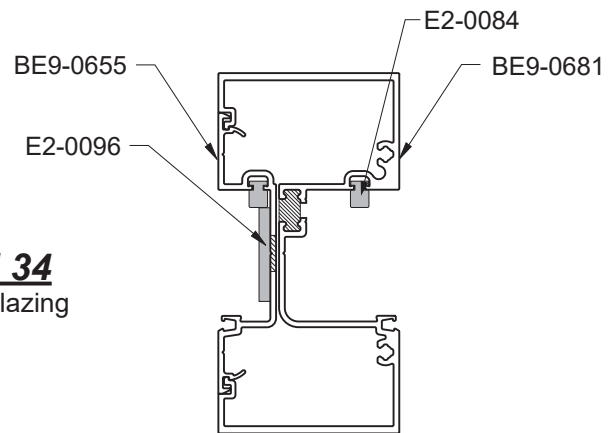

**Detail 34A**  
Inside Glazing

## GLAZING

### STEP 18 (Continued) GLAZING

- Carefully install glass into the frame making sure that the side blocks are properly aligned with the glass. Impact resistant glass is **always** to the interior.
- Slide the glass into the deep vertical pocket and then slide over until contact is made with the side block in the shallow glazing pocket. This will ensure proper location of the glass.
- Lift the glass and place setting blocks at 1/4 points or according to the engineering calculations.

YHS 50 Dry Glaze applications require the installation of an anti-walk block, E2-0807, into each jamb and vertical deep glazing pocket of each lite centered along the daylight opening.

- Flatten the anti-walk block against the exterior surface of the glass and push it into the opening between the glass and the mullion until it is released into the glazing pocket. See **Detail 35**.

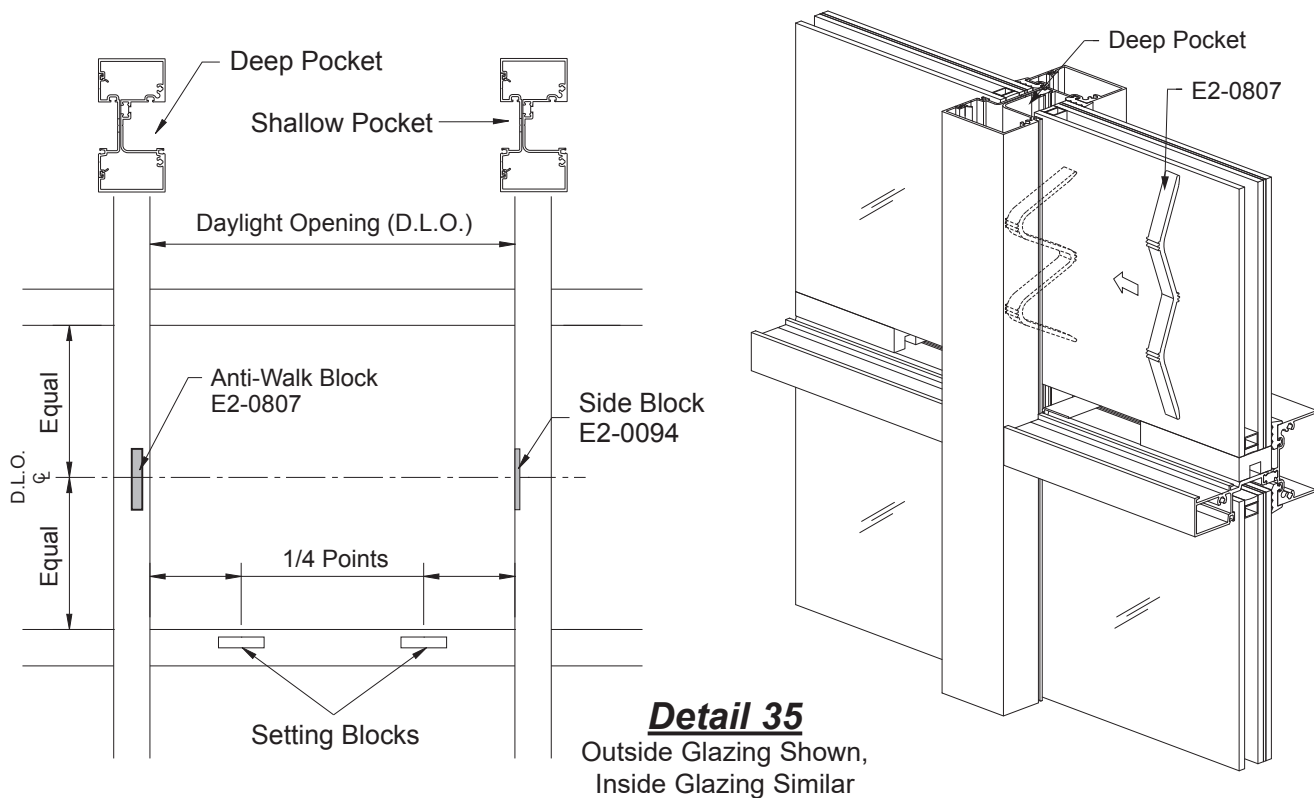

## GLAZING

### STEP 18 (Continued) GLAZING

- Install glass stop, E9-0658.
- Install the vertical exterior gaskets first. Roll the gasket in working from the center towards each end.
- Then install the horizontal exterior gaskets. Install each end and the center of the gasket into the reglet and roll in the remainder of gasket working from the center towards each end.

See **Detail 36 & 36A**.

- Install glass in the door using the same technique described above.

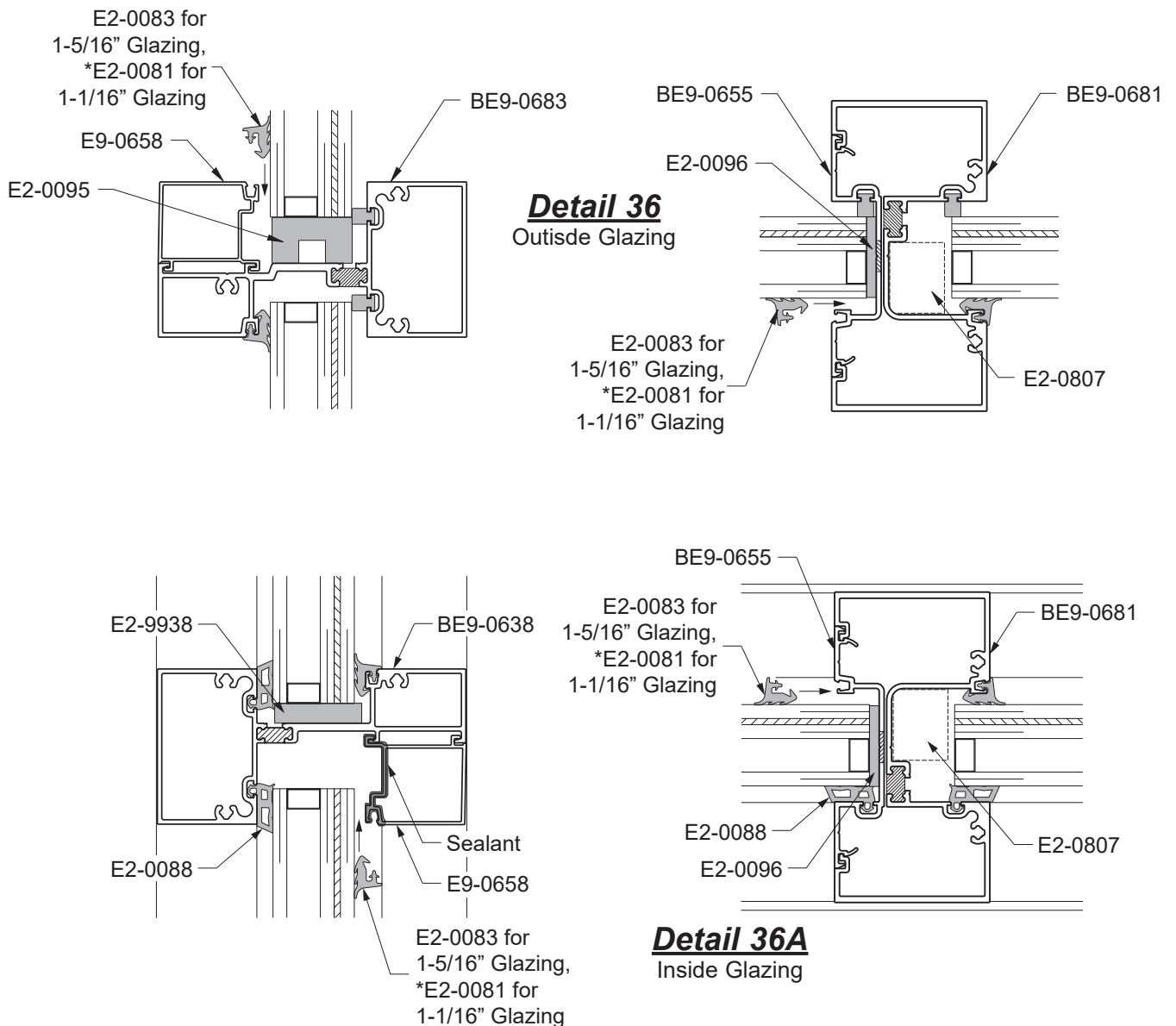

\* Not Florida Approved

**GLAZING**

**STEP 18 (Continued)  
GLAZING**

The following steps are for applications where structural silicone is required on the interior.

- Clean all sealant contact surfaces on metal and glass using method approved by sealant manufacturer.
- Apply masking tape to the aluminum and glass according to **Detail 37**.

**Note:** Apply tape to the glass 1/8" away from the aluminum to provide a 30° bevel.

- Apply approved structural silicone sealant from the bottom to the top of joint.
- Use positive pressure so that sealant completely fills the cavity between glass and aluminum.
- Using a 30° nylon beveled spatula, or other non-scratching implement, tool the structural silicone sealant immediately after running the joint. Exert positive pressure while tooling sealant to ensure that the silicone makes complete contact with all surfaces.

**Note:** Be careful not to remove too much silicone.  
The finished joint should be 30° beveled around the glass.

- Immediately remove masking tape while wet; do not allow silicone to skin.
- Masking tape must be removed within 10 minutes of tooling.

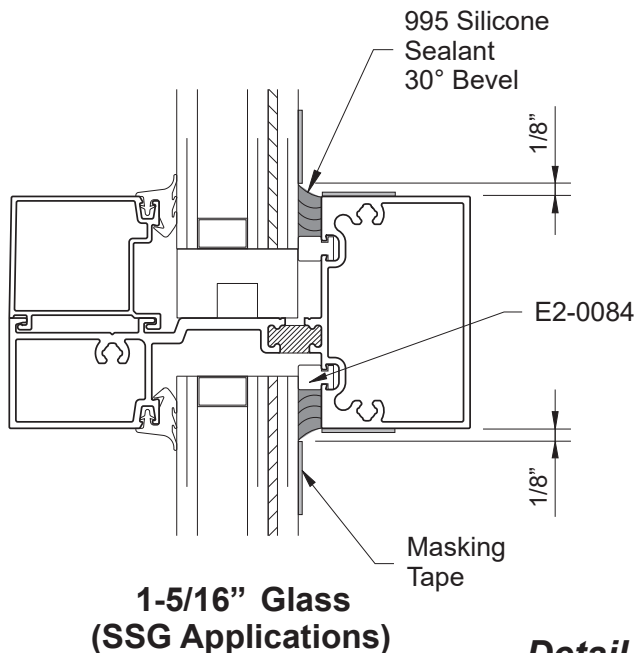

**Detail 37**

**Glazing Options**

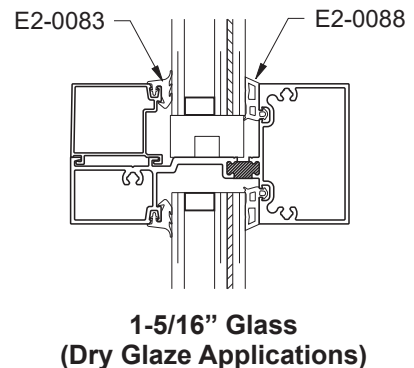
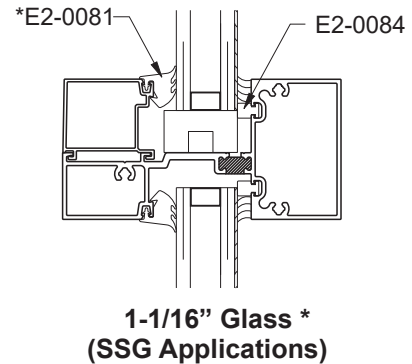

\* Not Florida Approved



## GLAZING

### STEP 19 INSTALL INTERIOR SNAP COVER

-For Inside Glazing applications, snap the Y7-9599 snap cover into the sill as shown in **Detail 38**.

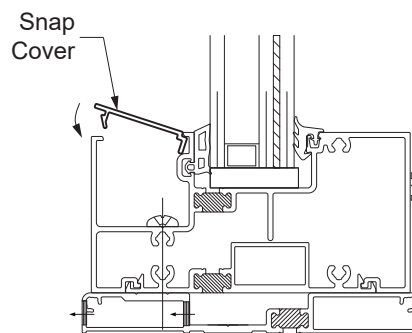

**Detail 38**



101 Marietta Street NW  
Suite 2100  
Atlanta, Georgia 30303  
[www.ykkap.com](http://www.ykkap.com)