

YES 600 Thermal Clip Storefront System

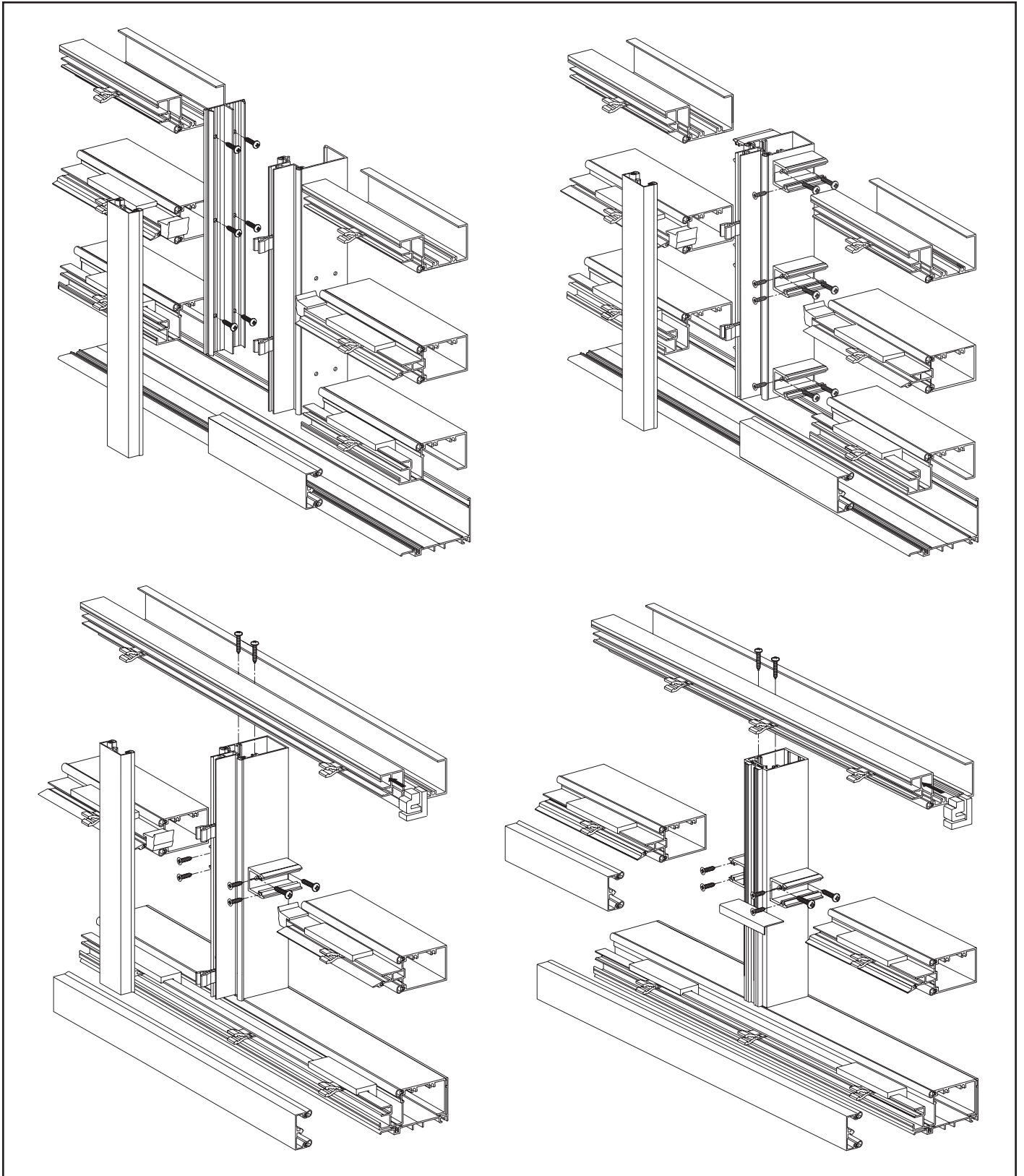

Installation Manual

TABLE OF CONTENTS

Installation Notes Page ii
Frame Types Page iii to iv

PARTS DESCRIPTION

Framing Members Pages 1 & 2
Door Framing Members Page 3
Accessories Pages 4 to 5

FRAME FABRICATION

Determine Frame Size..... Page 6
Fabricate Sill Flashing Page 7
Fabricate Two Piece Verticals for Screw Spline Assembly..... Page 8
Fabricate Tubular Verticals for Shear Block Assembly Page 9
Fabricate Head and Sill Members Pages 10 & 11
Fabricate Intermediate Horizontal Members Page 12
Fabricate Glazing Adaptors Page 12
Fabricate Face Covers Page 13

FRAME ASSEMBLY

Install Mullion End Caps Page 14
Assemble Vertical Through Frames Page 15 & 16
Assemble Continuous Head & Sill Frames Page 17

FRAME INSTALLATION

Install Sill Flashing..... Pages 18 to 21
Install Frames Page 22
Seal Door Jamb to Sill Flashing Page 23
Apply Internal Sealant Page 23
Install Joint Plugs & Water Deflectors Page 24
Apply Perimeter Sealant..... Page 25
Install Glazing Adaptors..... Page 25

GLAZING

Glazing Standard Frames..... Pages 26 & 27
Glazing Structural Silicone Glazed Frames..... Pages 28 to 30

Installation Notes

1. Do not drop, roll or drag boxes of aluminum framing. Move and stack boxes with proper support to prevent distortion. If fork lifts are used be especially careful about striking the boxes when lifting or moving.
2. Store in a dry, out of the way area. If rain exposure, condensation or any water contact is likely, then all packaging material should be removed. Wet packaging materials will discolor and may stain aluminum finishes and paints.
3. All materials should be checked for quality and quantity upon receipt, YKK AP must be notified immediately of any discrepancies in shipment. Check to make sure that you have the required shims, sealants, supplies and tools necessary for the installation.
4. Carefully check the openings and surrounding conditions that will receive your material. Remember, if the construction is not per the construction documents, it is your responsibility to notify the general contractor in writing. Any discrepancies must be brought to the general contractor's attention before you proceed with the installation.
5. Gather your shop drawings, materials, packing list, and this installation manual. Carefully review parts location, the sequence it goes therein, when you glaze it and how you seal it. Installation instructions are of a general nature and may not cover every condition you will encounter. The shop drawings and/or installation manuals were prepared specifically for the product.
6. Any material substitutions must be of equal or greater quality.
7. Make certain that material samples have been sent for compatibility testing for all manufacturer's sealants involved. Make certain sealants have been installed in strict accordance with the manufacturer's recommendations and specifications.
8. Remember to isolate, in an approved manner, all aluminum from uncured masonry or other incompatible materials.
9. System-to-structure fasteners are not supplied by YKK AP. Fasteners called out on shop drawings are to indicate minimum sizes for design loading.
10. Entrances are to be installed plumb, square, level and true.
11. If any questions arise concerning YKK AP products or their installation, contact YKK AP for clarification before proceeding.
12. YKK AP storefront and/or curtain wall framing is typically completed before drywall, flooring and other products which may still be in process. Wrap and protect the material when stored at the job site.
13. Cutting tolerances are plus zero (0"), minus one thirty second (-1/32") unless otherwise noted.
14. Check our website, www.ykkap.com, for the latest installation manual update prior to commencing work.

FRAME TYPES

SCREW SPLINE

- Verticals are cut to the full height of the frame.
- Horizontal members are cut in between the verticals mullions.
- Intermediate verticals consist of two separate pieces thus permitting sections of framing to be assembled and then snapped together.
- Intermediate horizontals are joined to verticals by screw spline attachment thus eliminating the requirement for shear blocks.
- Expansion verticals, placed approximately every twelve to fifteen feet, allow for long continuous runs of YES 600 framing.

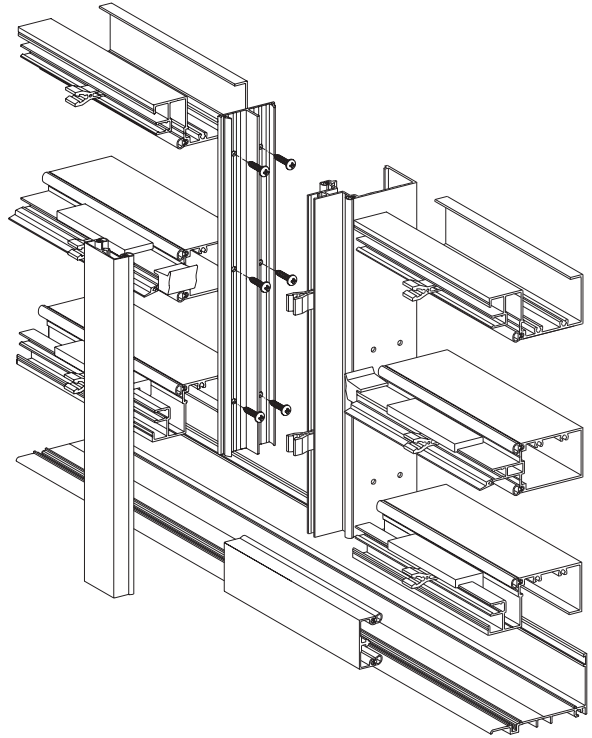

SHEAR BLOCK

- Verticals are cut to the the height of the frame.
- Horizontal members are cut in between the verticals mullions.
- Intermediate verticals are one piece members.
- All horizontals are attached to the verticals with shear blocks.

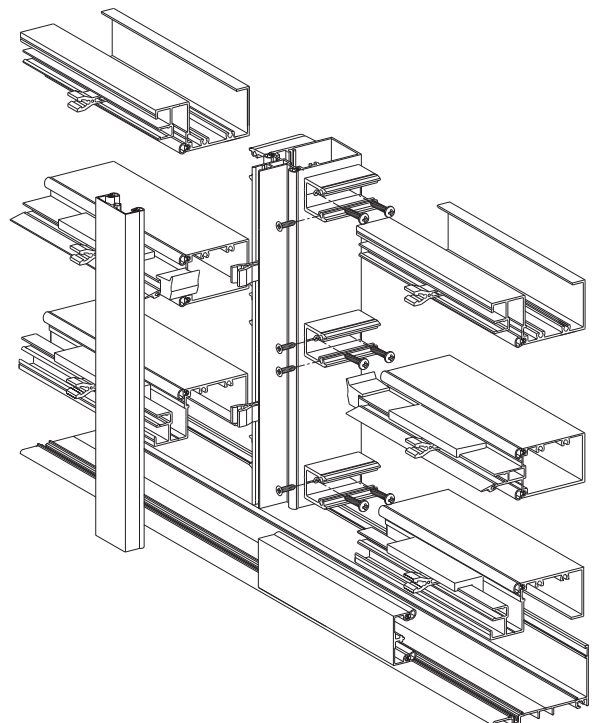

FRAME TYPES**CONTINUOUS HEAD AND SILL**

- Head and sill members run the full width of the frame opening for openings 24'-0" or smaller.
- Intermediate verticals are cut to the day light opening between the head and sill members.
- Fasteners are run through the head and sill into the screw splines of the one piece intermediate verticals.
- Intermediate horizontals are attached to verticals with shear blocks.

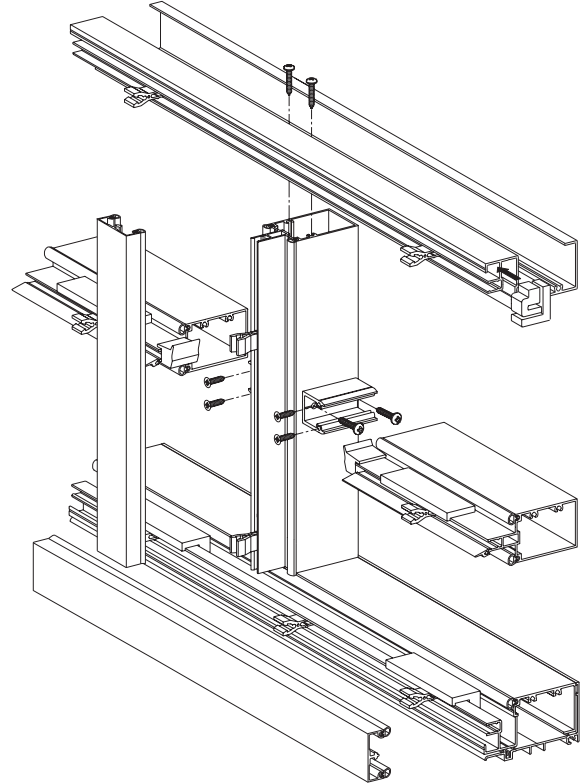



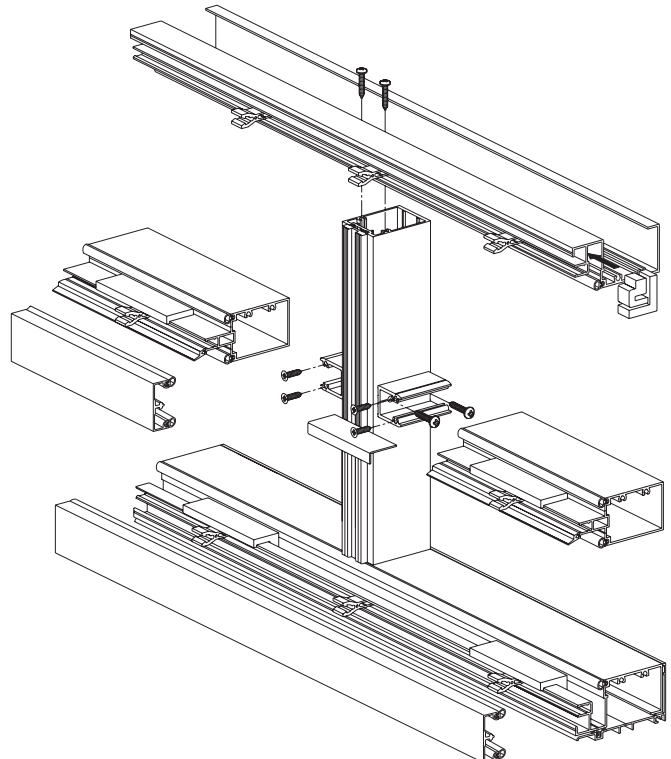





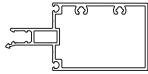
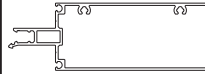
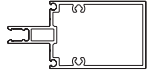
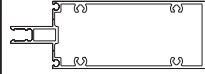
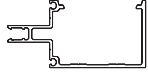

**STRUCTURAL SILICONE GLAZED**

- Vertical structural silicone glazing is available for the YES 600 Storefront Framing System.
- System description and fabrication is the same as for the continuous head and sill frame type described above.



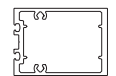
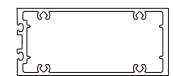
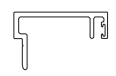

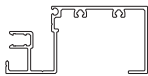
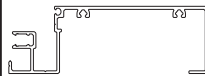
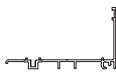

**GENERAL NOTES:**

- A qualified person must review shop drawings for system application and anchor sizing and spacing.













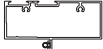

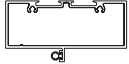







FRAMING MEMBERS

	Horizontal 1-3/4" x 4-1/2"	E9-1801		Horizontal 1-3/4" x 6"	E9-1811
	Tubular Vertical 1-3/4" x 4-1/2"	E9-1803		Tubular Vertical 1-3/4" x 6"	E9-1813
	Two Piece Vertical 1-3/4" x 4-1/2"	E9-1804		Two Piece Vertical 1-3/4" x 6"	E9-1814
	Flat Filler Use with E9-1804	E9-1805		Flat Filler Use with E9-1814	E9-1038
	Expansion Mullion 1-3/4" x 4-1/2" Female Weathering Gasket E2-0065 Not Included	E9-1806		Expansion Mullion 1-3/4" x 6" Female Weathering Gasket E2-0065 Not Included	E9-1816
	Expansion Mullion 1-3/4" x 4-1/2" Male Use with E9-1806	E9-1807		Expansion Mullion 1-3/4" x 6" Male Use with E9-1816	E9-1817
	SSG Vertical 1-3/4" x 4-1/2"	E9-1808		SSG Vertical 1-3/4" x 6"	E9-1818
	SSG Expansion Mullion, 1-3/4" x 4-1/2" Use with Self Weathering Gasket E2-0065 Not Included	E9-1824		SSG Expansion Mullion 1-3/4" x 6" Use with Self Weathering Gasket E2-0065 Not Included	E9-1825
	Head/Sill/Jamb 1-3/4" x 4-1/2"	E9-1821		Head/Sill/Jamb 1-3/4" x 6"	E9-1822
	Sill Flashing For 4-1/2" Deep System	E9-1868		Sill Flashing For 6" Deep System	E9-1869

FRAMING MEMBERS

 <p>Glazing Adaptor For 1/4" GlazingV</p>	<p>E9-1809</p>	 <p>Face Cover 5/8" x 1-3/4"</p>	<p>E9-1851</p>
 <p>SSG Glazing Adaptor For 1/4" Glazi</p>	<p>E9-1810</p>	 <p>Face Cover 1-5/8" x 1-3/4"</p>	<p>E9-1852</p>
 <p>Pocket Filler</p>	<p>E9-1823</p>	 <p>Face Cover 2-1/8" x 1-3/4"</p>	<p>E9-1853</p>









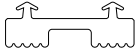

DOOR FRAMING MEMBERS

	Single Acting Door Jamb 1-3/4" x 4-1/2" E2-0051 Included	AS-0479		Single Acting Door Jamb 1-3/4" x 6" E2-0051 Included	AS-0471
	Single Acting Transom Bar for Offset Glazing 1-3/4" x 4-1/2" E2-0051 Included	AS-0477		Single Acting Transom Bar for Offset Glazing 1-3/4" x 6" E2-0051 Included	AS-0472
	Single Acting Transom Bar for Center Glazing 1-3/4" x 4-1/2" E2-0051 Included	AS-0402		Double Acting Door Jamb 1-3/4" x 6"	E9-0473
	Double Acting Door Jamb 1-3/4" x 4-1/2"	E9-0480		Double Acting Transom Bar for Offset Glazing 1-3/4" x 6" E2-0062 Included	AS-0474
	Double Acting Transom Bar for Offset Glazing 1-3/4" x 4-1/2" E2-0062 Included	AS-0478		Door Jamb Glazing Pocket Filler For 1" Glazing, Use with AS-0471 & E9-0473	E9-1891
	Door Jamb Glazing Pocket Filler For 1" Glazing, Use with AS-0479 & E9-0480	E9-1889		Door Jamb Glazing Pocket Filler For 1/4" Glazing, Use with AS-0471 & E9-0473	E9-1892
	Door Jamb Glazing Pocket Filler For 1/4" Glazing, Use with AS-0479 & E9-0480	E9-1890		Door Stop O/P Assembly Elastomer Weathering E2-0051 Included	AS-0409
	Intermediate Door Jamb 1-3/4" x 4-1/2" Use with AS-0409	E9-0410		Door Stop Base Used with AS-0409	E9-1113
	Sash Base Use with E9-0403 & E9-0413 Glass Stops	E9-0408		Transom Glazing Pocket For 1/4" Glazing	E9-0434
	Transom Glass Stop For 1/4" Glazing	E9-0403		Transom Glazing Pocket For 1" Glazing	E9-0435
	Transom Glass Stop For 1" Glazing	E9-0413		Threshold 1/2" x 4"	E9-0407

ACCESSORIES

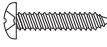
 <p>Shear Block For 4-1/2" Deep System Use (2) HM-1012 & (2) FC-1012, Not Included</p>	<p>E1-1030</p>	 <p>Setting Block For 1/4" Glazing at Transom Head</p>	<p>E2-0019</p>
 <p>Shear Block For 6" Deep System Use (2) HM-1012 & (2) FC-1012, Not Included</p>	<p>E1-1031</p>	 <p>Setting Block For 1" Glazing at Transom Head</p>	<p>E2-0056</p>
 <p>SSG Water Deflector For Ends of Horizontals at SSG Verticals</p>	<p>E1-1032</p>	 <p>Setting Block For 1/4" & 1" Glazing at Intermediate Horizontal</p>	<p>E2-0202</p>
 <p>Temporary Glass Retainer For Structural Silicone Glazing</p>	<p>E1-1033</p>	 <p>Setting Block For 1/4" & 1" Glazing at Sill</p>	<p>E2-0253</p>
 <p>Deglazing Tool</p>	<p>E1-1034</p>	 <p>Side Block</p>	<p>E2-0133</p>
 <p>Mullion End Cap</p>	<p>E1-1045</p>	 <p>Joint Plug For Horizontal Ends</p>	<p>E2-0208</p>
 <p>Glazing Clip</p>	<p>E3-0015</p>	 <p>End Dam For Continuous Head & Sill Frame Ends</p>	<p>E2-0278</p>
 <p>End Dam For Sill Flashing E9-1868</p>	<p>E1-0141</p>	 <p>End Dam For Continuous Head & Sill Frame Ends</p>	<p>E2-0276</p>
 <p>End Dam For Sill Flashing E9-1869</p>	<p>E1-0142</p>	 <p>Water Deflector For Neck of Horizontals</p>	<p>E2-0254</p>
 <p>Silicone Splice Sheet For Sill Flashing</p>	<p>E2-0070</p>	 <p>Glazing Gasket Interior & Exterior</p>	<p>E2-0213</p>

ACCESSORIES

	<p>SSG Glazing Spacer For Structural Silicone Glazing of Intermediate Verticals</p>	<p>E2-0214</p>	 <p>#10-24 x 3/8" PHMS, Stainless Steel For Attachment of Sill to Sill Flashing</p>	<p>PM-1006 -SS</p>
	<p>Elastomer Weathering Use with Door Frame</p>	<p>E2-0051</p>	 <p>#10 x 3/4" FHSMS Type AB, Zinc Plated Steel, For Attachment of Horizontal to Shear Block</p>	<p>FC-1012</p>
	<p>Weathering Gasket Use with E9-1806, E9-1816, E9-1824 & E9-1825</p>	<p>E2-0065</p>	 <p>#10-24 x 3/4" HWSMS Type AB, Zinc Plated Steel, For Attachment of Shear Block to Vertical</p>	<p>HM-1012</p>
	<p>Glazing Gasket For Transom Glazing</p>	<p>E2-0052</p>	 <p>#10 x 1" PHSMS Type AB, Zinc Plated Steel, For Screw Spline Attachment</p>	<p>PC-1016</p>
	<p>Pile Weathering</p>	<p>E2-0062</p>	 <p>#10 x 1-1/4" PHSMS Type AB, Zinc Plated Steel, For Screw Spline Attachment Using E9-1821 & E9-1822</p>	<p>PC-1020</p>
	<p>#10 x 3/8" PHSMS Type AB, Zinc Plated Steel, For Attachment of E9-1809 Glazing Adaptor to Mullion</p>	<p>PC-1006</p>	 <p>#12 x 3/4" UFHSMS Type A, Zinc Plated Steel For End Dam Attachment</p>	<p>UA-1212</p>

FRAME FABRICATION

STEP 1 DETERMINE FRAME SIZE

Determine Frame Width:

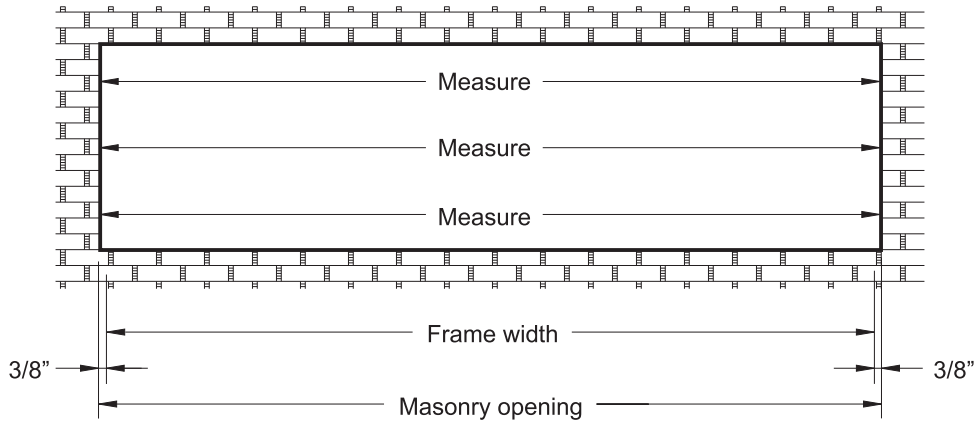

Note: Check opening for squareness of plumb at both ends, units must be installed in a true rectangle.

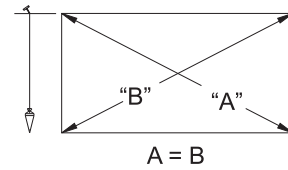

DETAIL 1

- Measure the width of the masonry opening at the top, middle, and bottom.
 - Select the smallest dimension measured and subtract 3/4" to determine the frame width.
- See **Detail 1**.

Determine Frame Height:

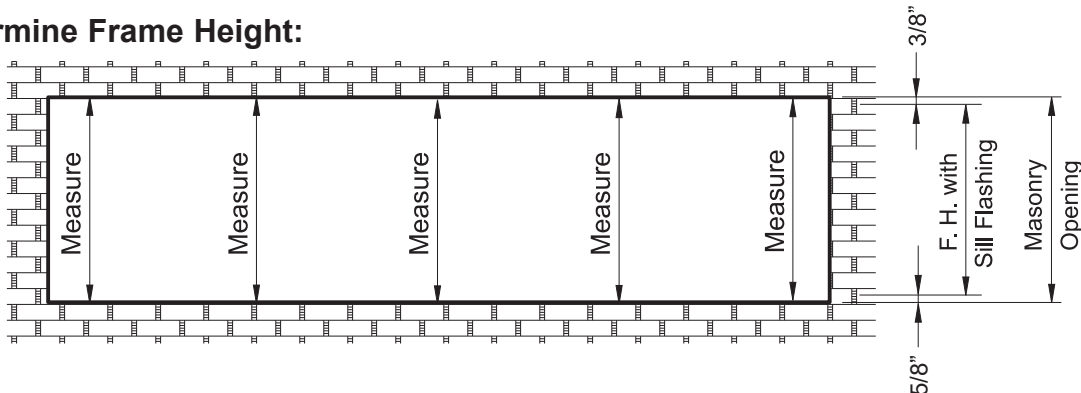

DETAIL 2

- Measure the height of the masonry opening several times along the entire length of opening and select the smallest dimension for the masonry opening height. See **Detail 2**.

To calculate frame height:

For All Frames:

- Subtract 1" from the masonry opening height:
 - 3/8" caulk joint at head.
 - 3/8" sill flashing.
 - 1/4" shim space below flashing.

NOTE: Frame widths over 24'-0" require expansion mullions every 12 to 15 feet (best location at vertical next to the door jamb.)
YES 600 must be installed with sill flashing, E9-1868 or E9-1869 for both vertical run thru and continuous head and sill.

FRAME FABRICATION

**STEP 2
FABRICATE SILL FLASHING**

For Elevations without Door Framing:

-Cut sill flashing, E9-1868 or E9-1869, to the frame width plus(+) 1/2" determined in **Step 1**.

For Elevations with Door Framing:

-Cut sill flashing, from the end of the frame plus(+) 1/4" to the door jamb.
(See approved shop drawings for this dimension)

See **Detail 3**.

-For openings longer than 24'-0" the sill flashing needs to be spliced every twelve to fifteen feet.
-Allow for a 3/8" joint for expansion between sill flashing members.

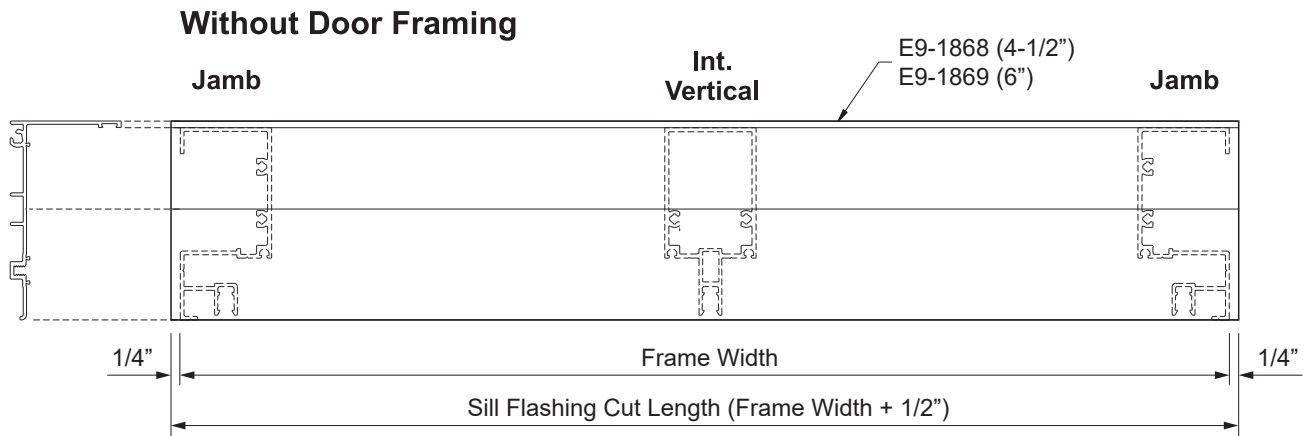

Detail 3
4-1/2" System Shown
6" System Similar

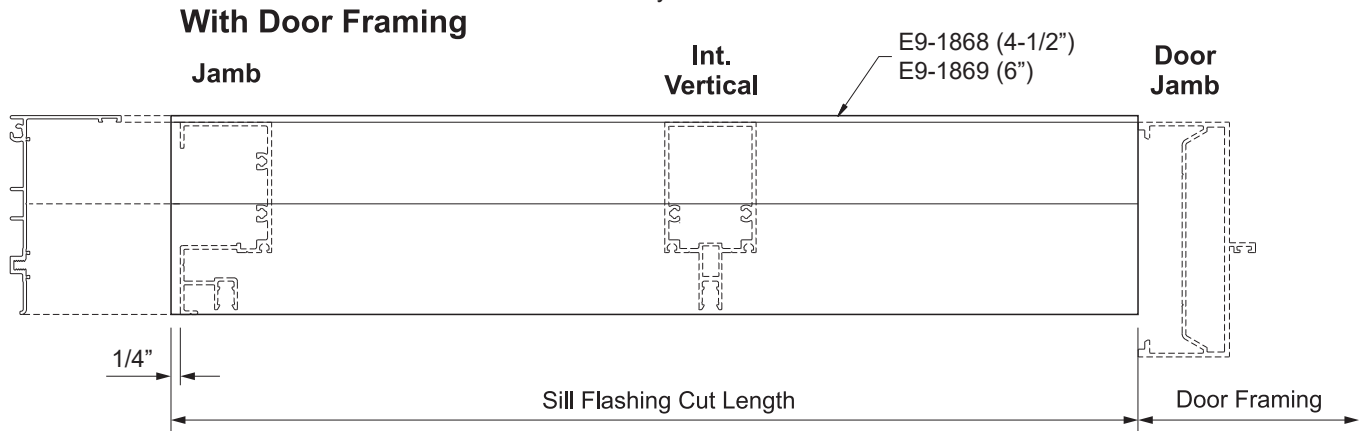

FRAME FABRICATION

STEP 3 FABRICATE TWO PIECE VERTICALS FOR SCREW SPLINE ASSEMBLY

-Cut the two piece vertical and jamb members to the frame height determined in **Step 1**.

-Mark hole locations for screw spline attachment using one of the methods below:

1. Using a short piece of each horizontal member as a template, align the glazing pockets and mark the location of each screw spline.

OR

2. Layout the hole locations as shown in **Detail 4**.

-Drill a 0.213" diameter (#3 drill bit) clearance hole at each location marked.

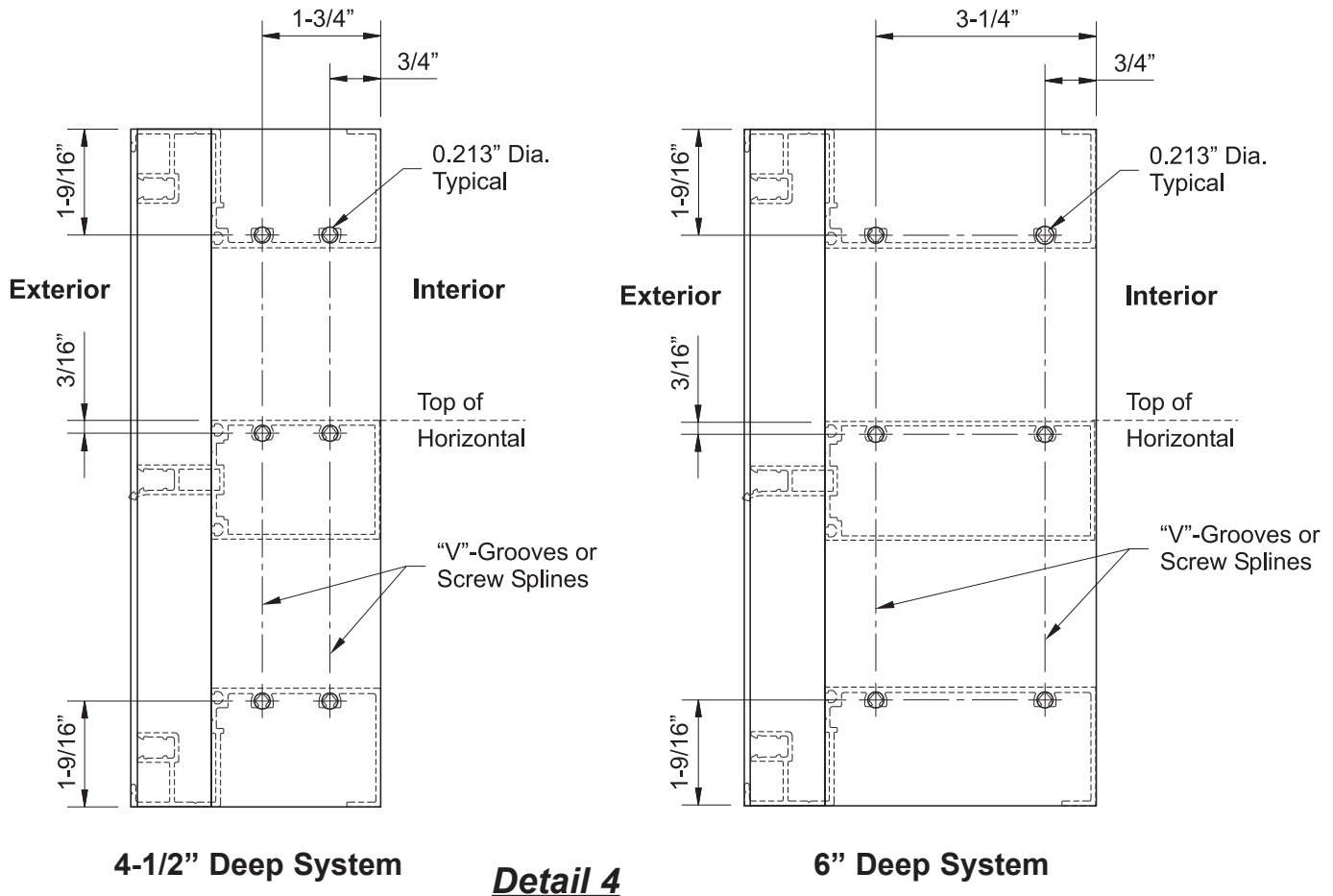

FRAME FABRICATION

**STEP 3 (Continued)
FABRICATE TUBULAR VERTICALS
FOR SHEAR BLOCK ASSEMBLY**

-Cut vertical and jamb members to the frame height determined in **Step 1**.
-Tubular verticals require mullion anchors for the attachment head and sill members and shear blocks for the attachment of horizontal members. Mark hole locations for mullion anchor and shear block attachment using one of the methods below:

1. Using a short piece of each horizontal member with a shear block attached as a template, align the glazing pockets and mark each hole location.

OR

2. Layout hole locations for the shear blocks as shown in **Detail 5**.

-Drill a 0.161" diameter (#20 drill bit) hole at each location marked.
-Attach mullion anchors and shear blocks to the mullions with (2) HM-1012 fasteners.

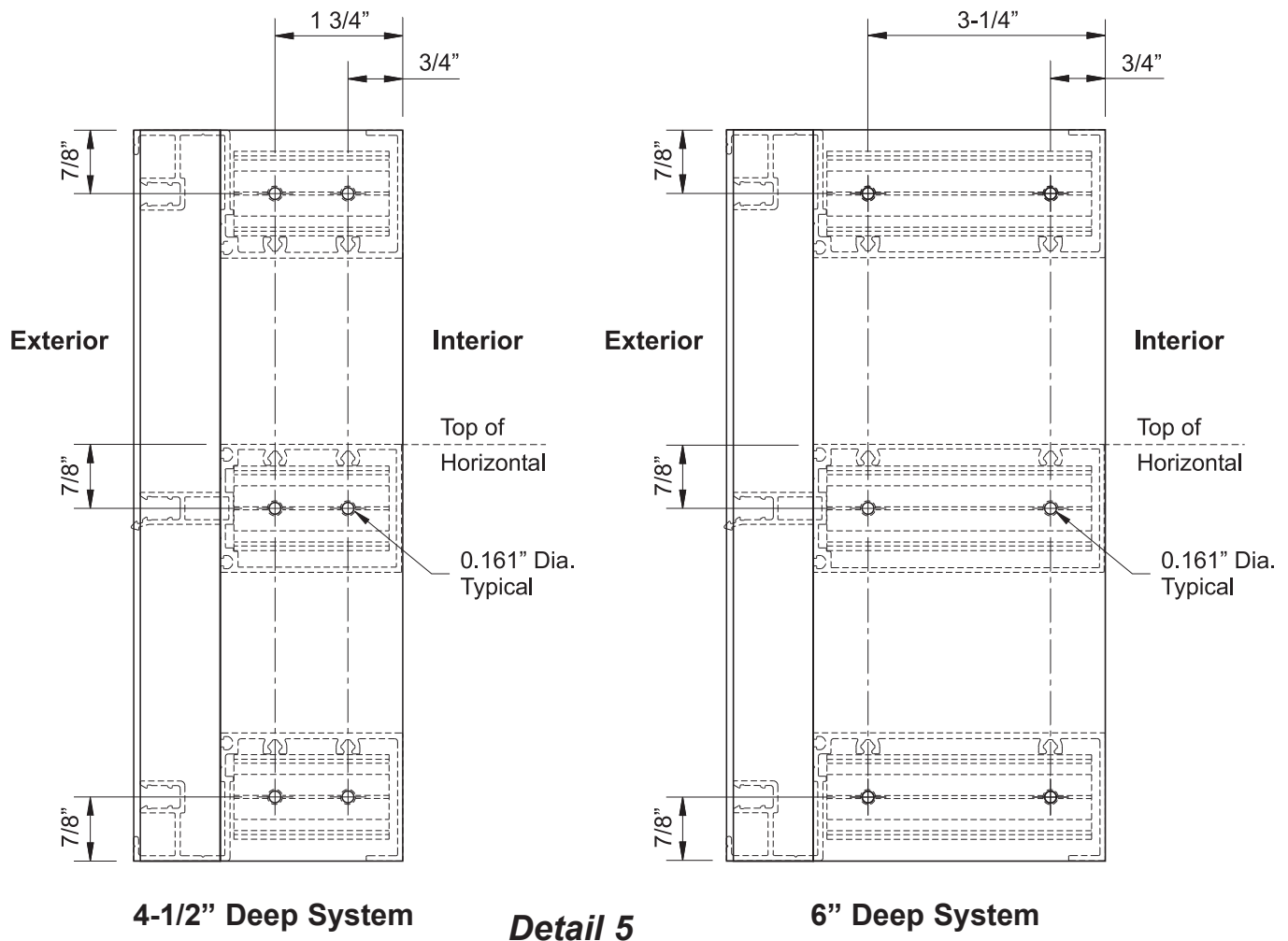

FRAME FABRICATION

STEP 4

FABRICATE HEAD AND SILL MEMBERS FOR VERTICAL THROUGH FRAMES

- Cut the head and sill members to the daylight opening (D.L.O.) between verticals.
- If using vertical mullion anchors, additional fabrication to the head and sill members is required:
 - Mark hole locations along the "V"-groove of the head or sill 1" from each end.
 - Drill a 0.213" diameter (#3 drill bit) hole at each location and countersink for a #10 fastener.

See **Detail 6**.

Detail 6
4-1/2" System Shown
6" System Similar

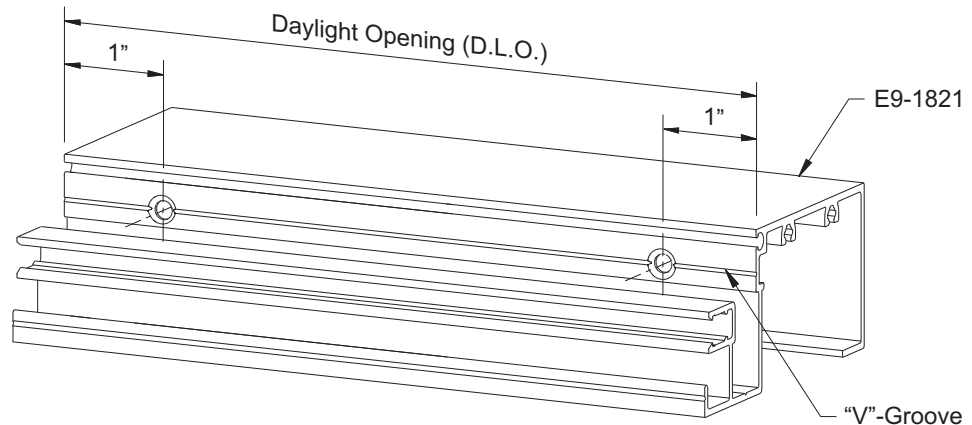

FABRICATE HEAD AND SILL MEMBERS FOR CONTINUOUS HEAD & SILL FRAMES

- Cut head and sill members to the frame width determined in **Step 1**.
- Continuous head and sill frames require weep holes at the sill:
 - Mark the sill members, E9-1821 or E9-1822, at 1/4 points of daylight opening between vertical members along the "V"-Groove on the front leg of the sill member as shown below.
 - Drill 5/16" diameter weep holes at each location marked through both the front and center leg of the sill member.

See **Detail 7**.

Detail 7
4-1/2" System Shown
6" System Similar

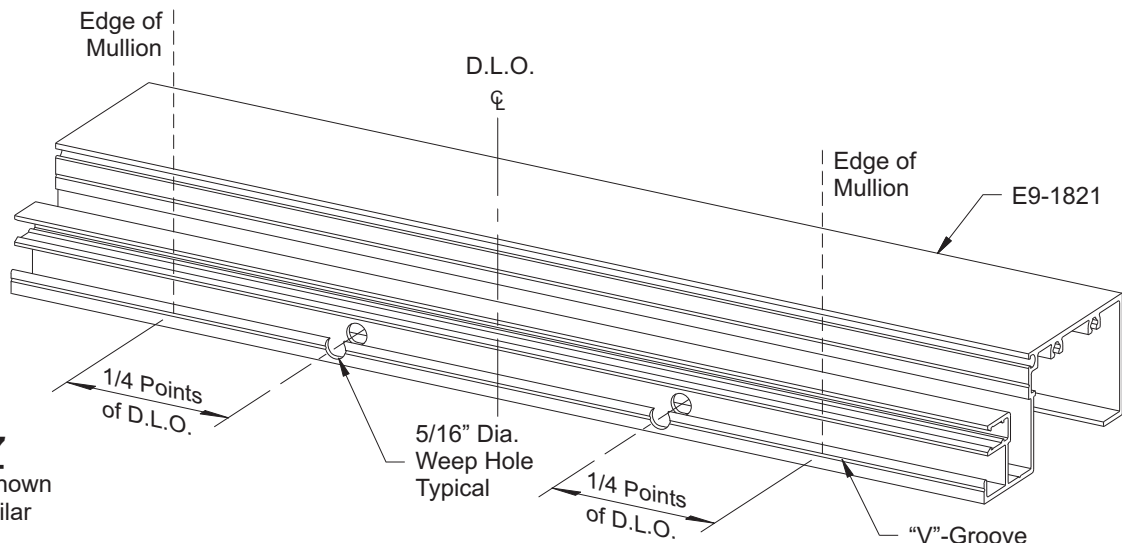

FRAME FABRICATION

STEP 4 (Continued)
FABRICATE HEAD AND SILL MEMBERS
FOR CONTINUOUS HEAD & SILL FRAMES

Fabricate holes in the head and sill members for the attachment of vertical members:

- Mark the centerlines of each intermediate vertical across the back of the head or sill.
- Using short pieces of vertical members as a template, center the template along the vertical centerlines and align the glazing pocket of the template with the head or sill.
- Mark hole locations through the screw splines.

OR

- Layout hole locations on head and sill members as shown below.
- Drill 0.213" diameter (#3 drill bit) clearance holes at each location marked.

See **Detail 8**.

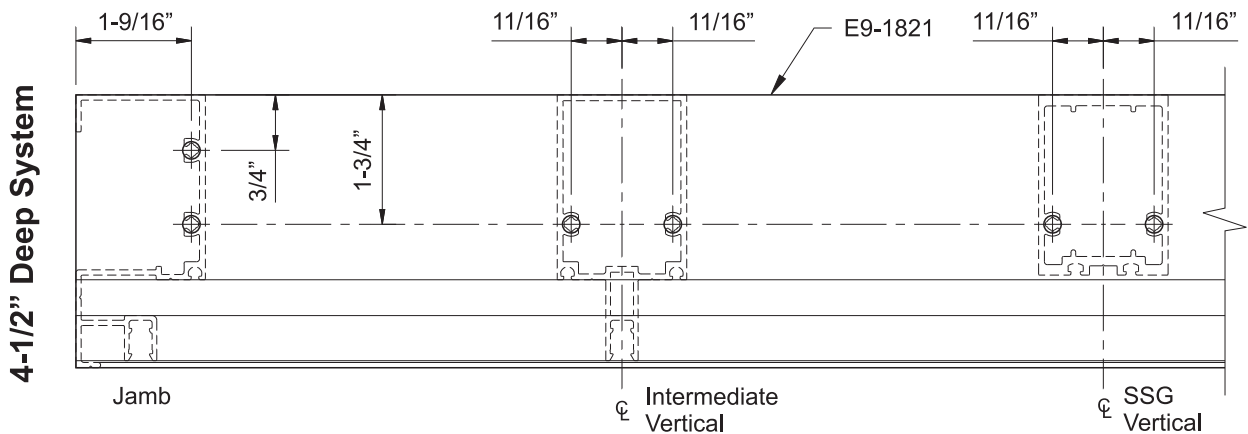

Detail 8

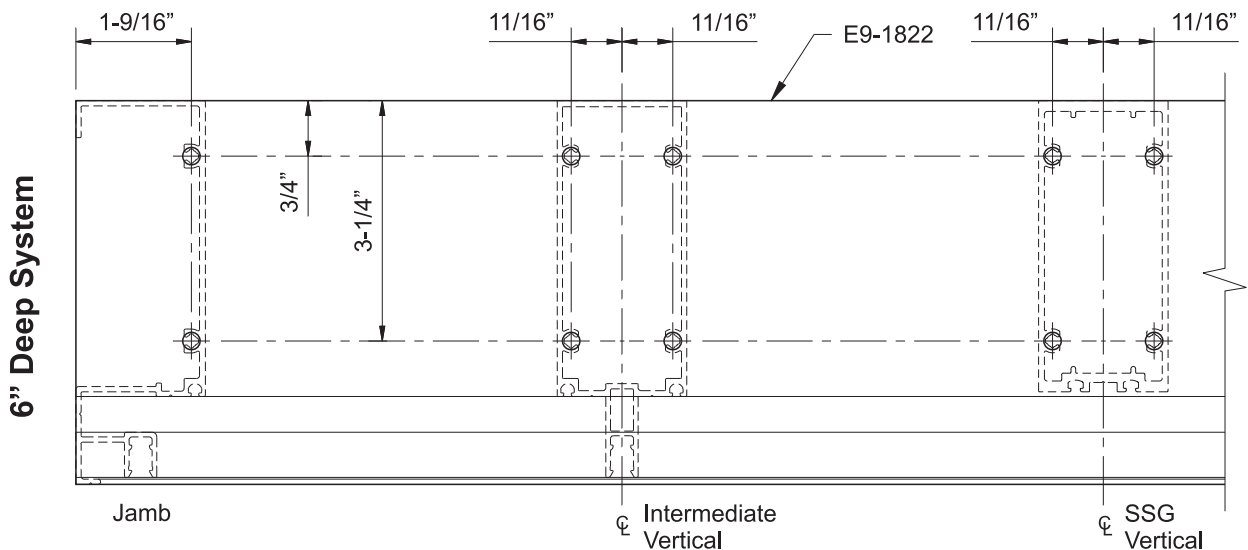

FRAME FABRICATION

STEP 5 FABRICATE INTERMEDIATE HORIZONTAL MEMBERS

-Cut all intermediate horizontal members to the daylight opening between verticals.

Horizontal members that are attached to one piece verticals by shear blocks require additional fabrication:

- Mark hole locations at each end, 1" from the ends along the "V"-Grooves on both sides of the mullion tongue.
- Drill 0.213" dia. (#3 drill bit) holes, countersunk for a #10 fastener, at each location marked.

See **Detail 9**.

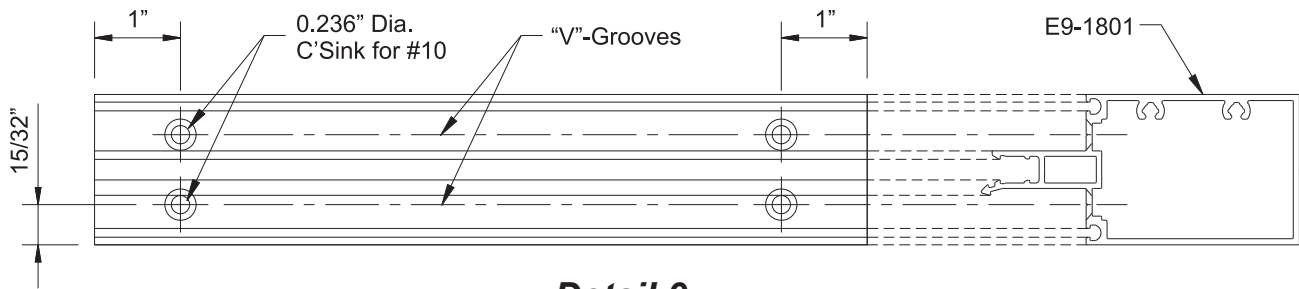

Detail 9

STEP 6 FABRICATE 1/4" GLAZING ADAPTORS (When Required)

- Cut glazing adaptors for verticals: Cut Length = Daylight Opening plus(+) 1".
- Cut glazing adaptors for horizontals: Cut Length = Daylight Opening minus(-) 1/32".
- Mark hole locations 2" from each end of all adaptors along the "V"-groove.
- Drill a 0.213" diameter (#3 drill bit) holes at each location marked.

See **Detail 10**.

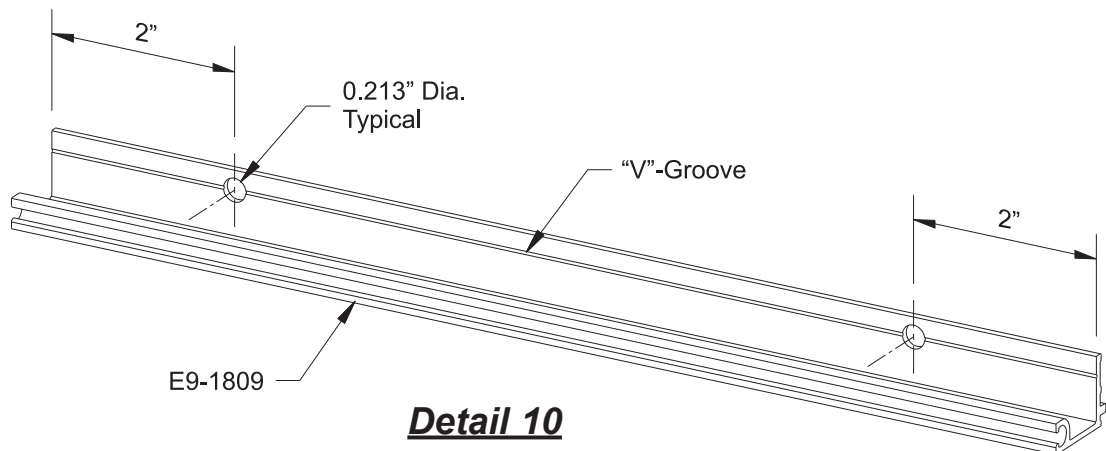

Detail 10

FRAME FABRICATION

STEP 7 FABRICATE FACE COVERS

For Vertical Through Frames:

- Cut vertical face covers to the same dimension as their respective vertical mullions.
- Cut horizontal face covers to the daylight opening between verticals minus(-) 1/32."

For Continuous Head & Sill Frames:

- Cut vertical face covers to the daylight opening height minus(-) 1/32."
- Cut head and sill face covers to the frame width determined in **Step 1**.
- Cut intermediate horizontal face covers to the daylight opening between verticals minus(-) 1/32" for captured mullions.

Note: If using SSG verticals, horizontal face covers may run continuous across SSG verticals. An expansion joint, 3/8" wide, is required every 12 to 15 feet; this joint should occur at the centerline of a SSG vertical. See approved shop drawings for horizontal face cover dimensions if using SSG verticals.

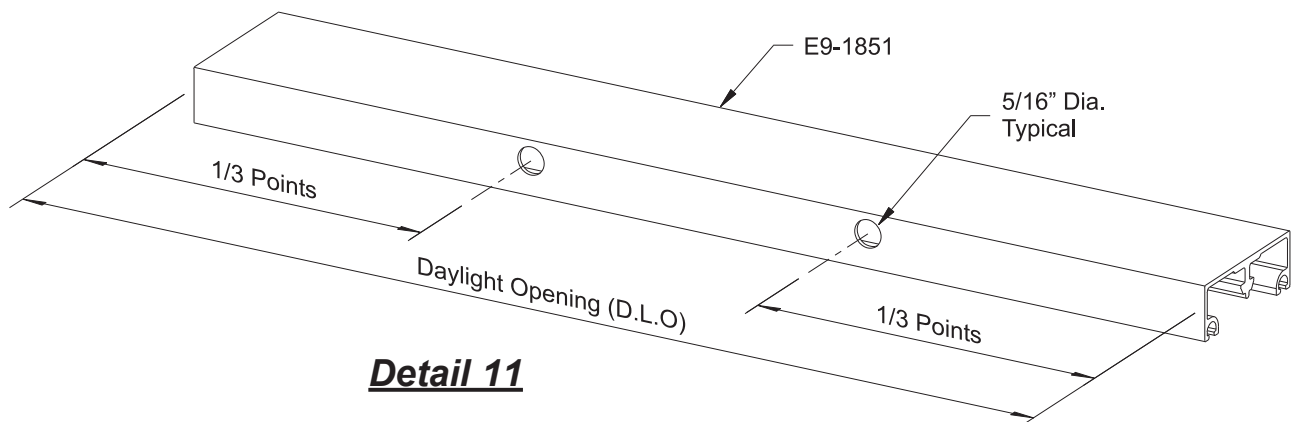

Detail 11

Intermediate horizontal face covers require weep holes on the bottom side of the face covers to permit water that has entered the system to properly weep out.

- Locate and mark the one third points of daylight opening (D.L.O.) along the bottom side of the face covers.
 - Drill 5/16" diameter weep holes at each location marked.
- See **Detail 11**.

Note: Each lite of glass to have two weep holes.

FRAME ASSEMBLY

STEP 8 INSTALL MULLION END CAPS (For Vertical Through Frames Only)

- Clean the top of the vertical mullion and mullion end caps with a cleaner and method approved by sealant manufacturer.
 - Apply sealant to the gasket reglets and along the front of the vertical members at the head prior to installing mullion end caps, E1-1045.
 - Attach mullion end caps to the top of vertical members using (2) FC-1012 fastener at each end.
 - Tool the excess sealant along the inside of the glazing pocket between the mullion end cap and the mullion.
 - Seal all screw heads.
- See **Detail 12**.

Note: End caps are also required for E9-1821 and E9-1822 when used as a jamb.

STEP 9 INSTALL END DAMS AT HEAD (For Continuous Head & Sill Frames Only)

The ends of head members of continuous head & sill frames must be plugged using end dams, E2-0276 and E2-0278, at both the head and sill.

Use the following technique to install end dams at the head:

- Clean the ends of the head members with a cleaner and method approved by the sealant manufacturer.
 - Apply sealant to all end dam surfaces that will contact the mullion.
 - Insert the end dams into each end, leaving it recessed from the end of the mullion.
 - Apply sealant to the end dams and tool the sealant flush with the ends of the mullion.
- See **Detail 13**.

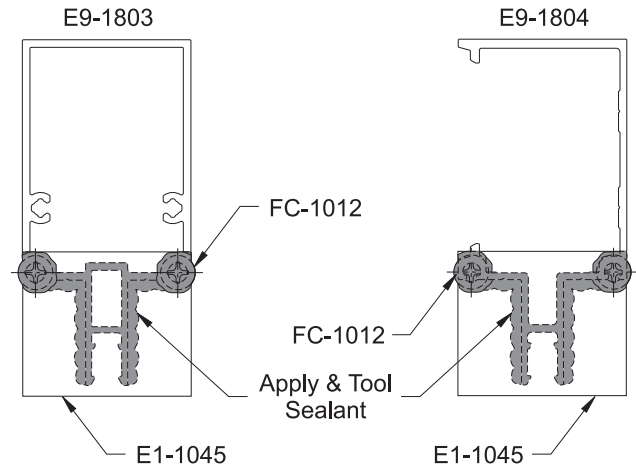

Detail 12

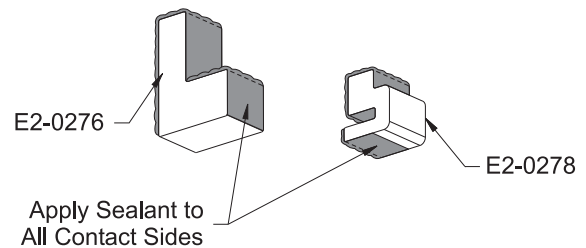

Detail 13

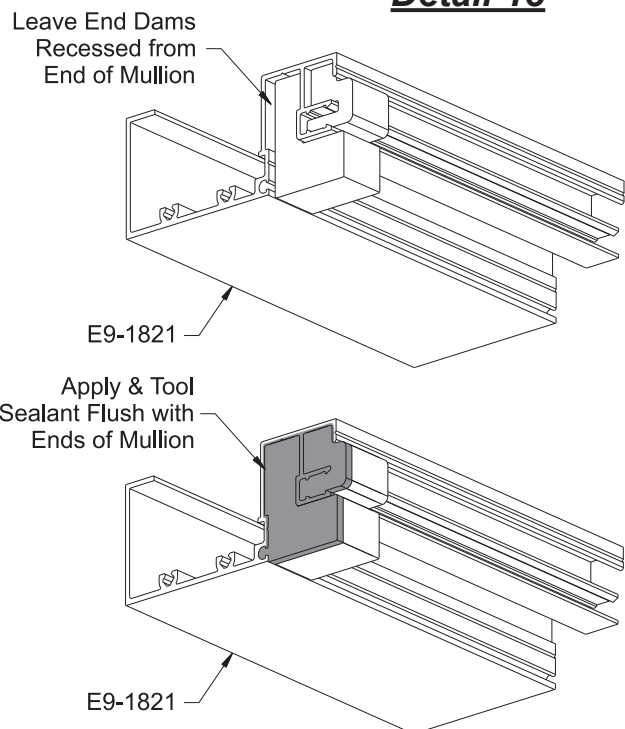

FRAME ASSEMBLY

STEP 10
ASSEMBLE FRAMES

Vertical Through Frames / Screw Spline Attachment:

- Clean the ends of horizontals and attachment areas of vertical members using a cleaner and method approved by sealant manufacturer.
- Apply sealant to both ends of head, horizontal, and sill members prior to assembly.
- Attach head, horizontal and sill members to the two piece vertical members with (2) PC-1016 fasteners at each end.
- Using a clean cloth, wipe off the excess sealant while pushing it into the joints.

See **Detail 14**.

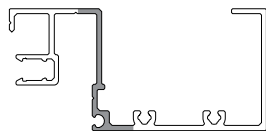

E9-1821
Head

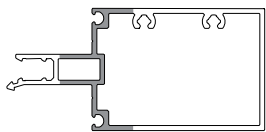

E9-1801
Horizontal

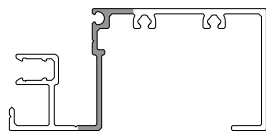

E9-1821
Sill

Apply sealant to the shaded areas at each end.

Screw Spline Attachment

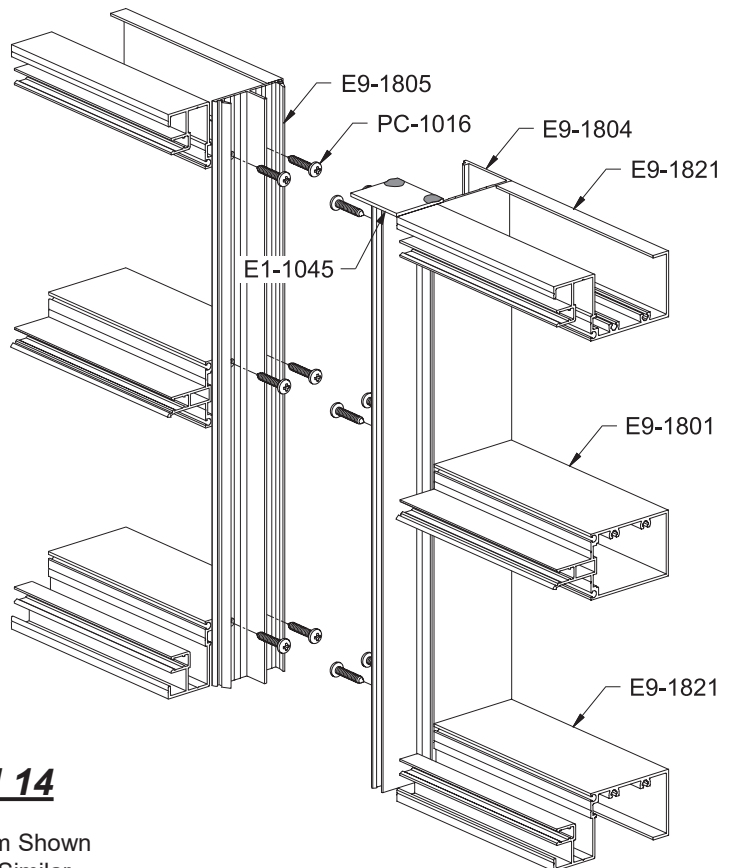

Detail 14

4-1/2" System Shown
6" System Similar

FRAME ASSEMBLY

STEP 10 (Continued) ASSEMBLE FRAMES

Vertical Through Frames / Shear Block Attachment:

- Clean the ends of horizontals and attachment areas of vertical members using a cleaner and method approved by sealant manufacturer.
- Apply sealant to both ends of head, horizontal, and sill members prior to assembly.
- Attach shear blocks to the verticals using HM-1012 fasteners, 2 per shear block
- Attach head, horizontal and sill members to the vertical members with FC-1012 fasteners, (2) per shear block at the intermediate horizontals, and (1) per shear block at the head and sill.
- Using a clean cloth, wipe off the excess sealant while pushing it into the joints.

See **Detail 15**.

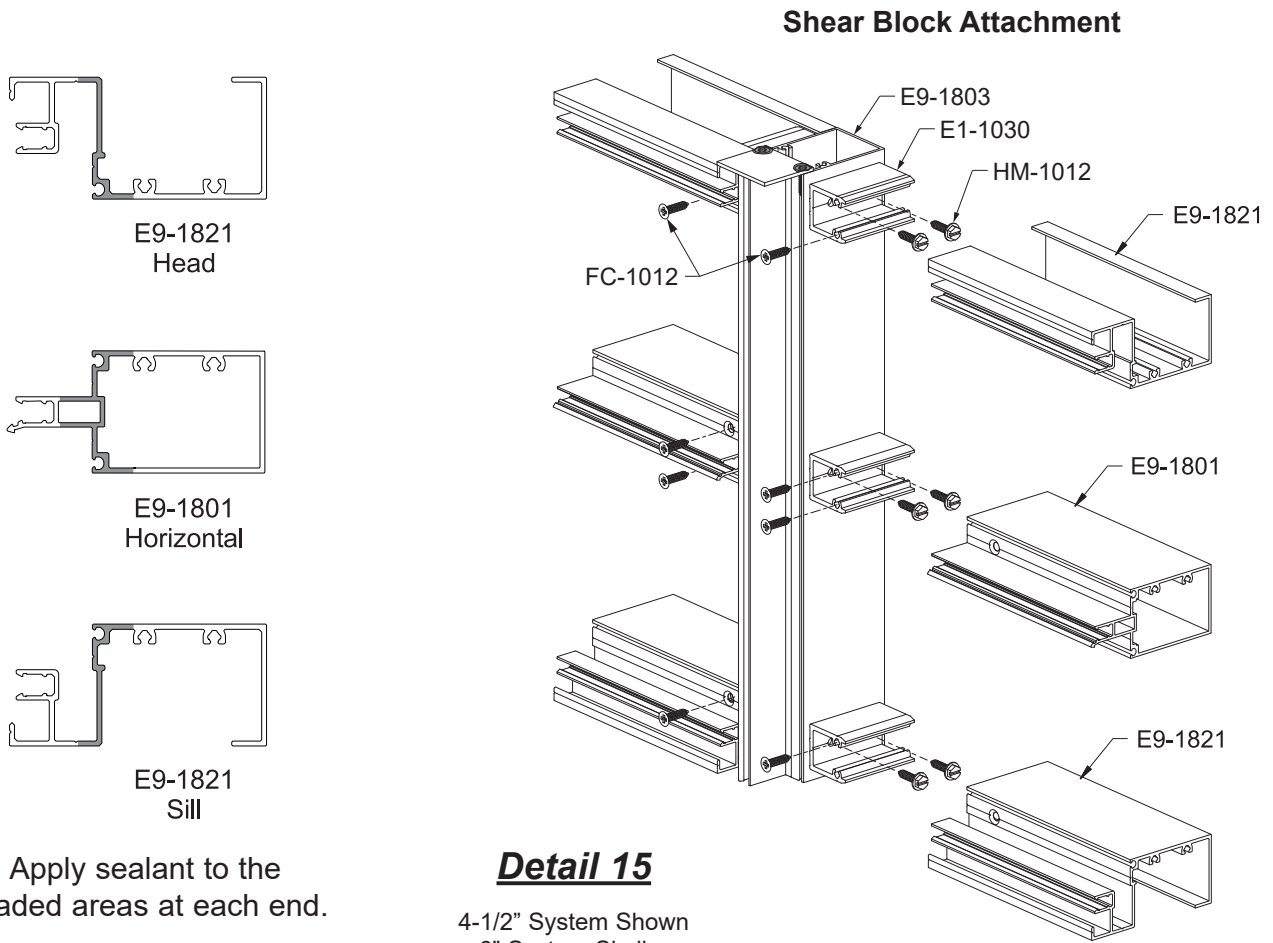

Apply sealant to the shaded areas at each end.

Detail 15

4-1/2" System Shown
6" System Similar

FRAME ASSEMBLY

STEP 10 (Continued)
ASSEMBLE FRAMES

Continuous Head & Sill Frames:

- Clean the ends of vertical members and attachment areas of head and sill members using a cleaner and method approved by sealant manufacturer.
- Apply (butter) sealant to both ends of jamb and vertical members just prior to assembly.
- Attach jamb and vertical mullions to the head and sill members using:
 - (2) PC-1016 fasteners for 4-1/2" deep verticals.
 - (4) PC-1016 fasteners for 6" deep verticals.
- Apply (butter) sealant to both ends of the intermediate horizontal members and to the front, top portion of the shear block just prior to assembly.
- Attach intermediate horizontals to the shear blocks using (2) FC-1012 fasteners at each end.
- Using a clean cloth, wipe off the excess sealant while pushing it into the joints.

See **Detail 16**.

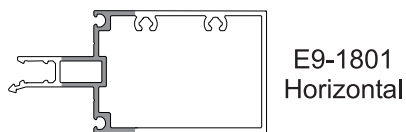
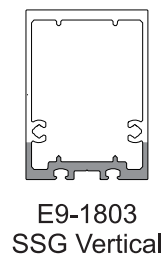
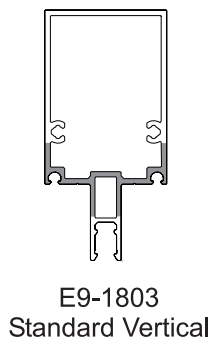
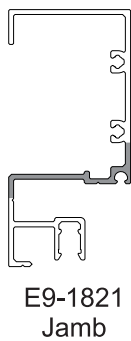

Apply sealant to the shaded areas at each end.

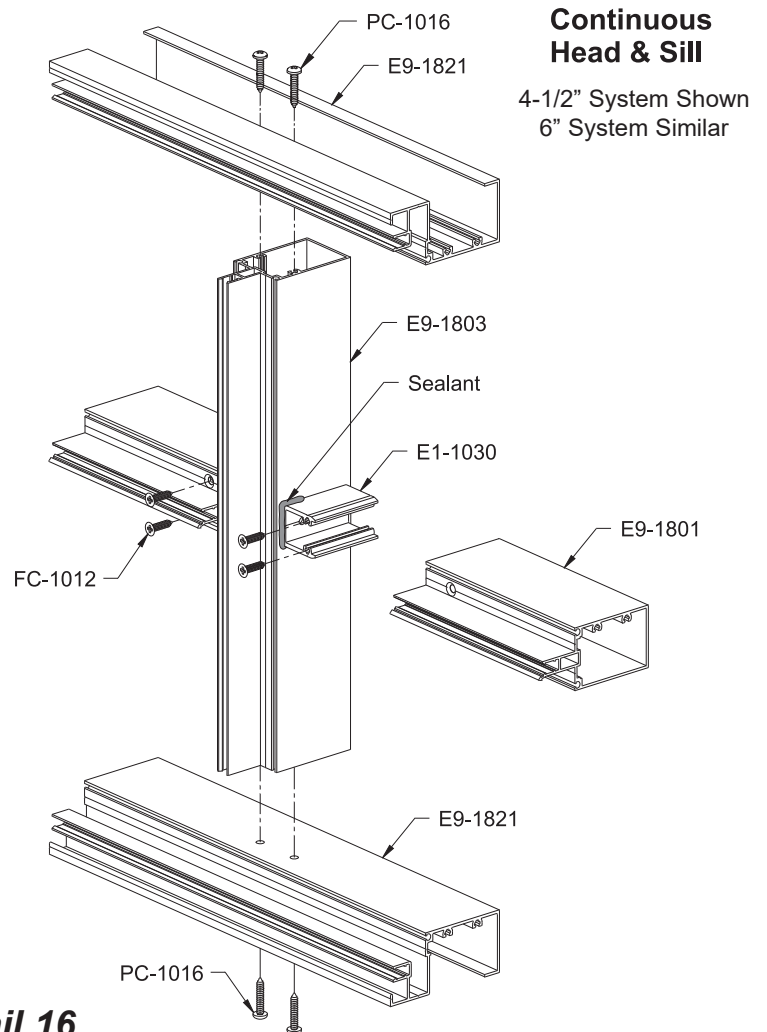

Detail 16

FRAME INSTALLATION

STEP 11 INSTALL SILL FLASHING END DAMS

-Bend the end dam tab left or right 90 degrees in order to hand the end dam for the left or right of the flashing.

See **Details 17 & 18**.

- Clean all joint surfaces using cleaner approved by sealant manufacturer.
- Apply sealant to the end of the sill flashing as shown in **Detail 19**.
- Slide the tab into the top portion of the sill flashing.
- Tap the tab into place with a small tool until the end dam is snug against the cut end of the flashing.
- Fasten end the end dam to the sill flashing with two UA-1212 screws, starting at the back followed by the front as shown in **Detail 19**.
- Tool sealant along the joint between the end dam and the sill flashing as shown in **Detail 20**.
- Seal over any exposed screw threads.

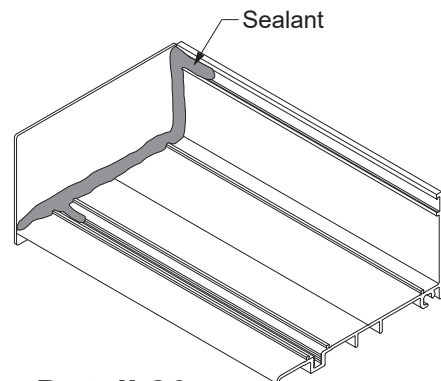
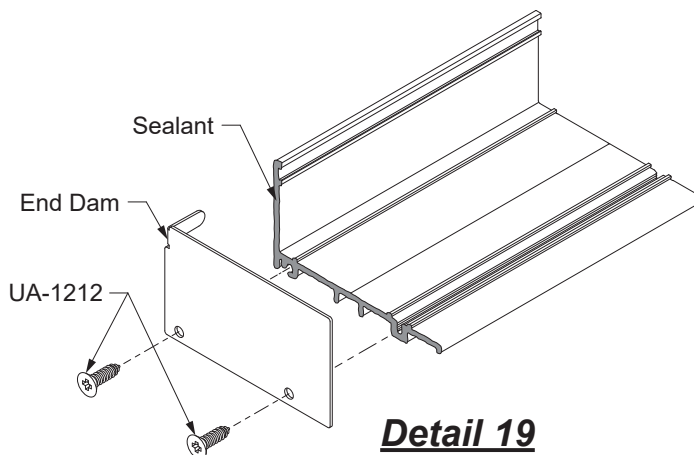
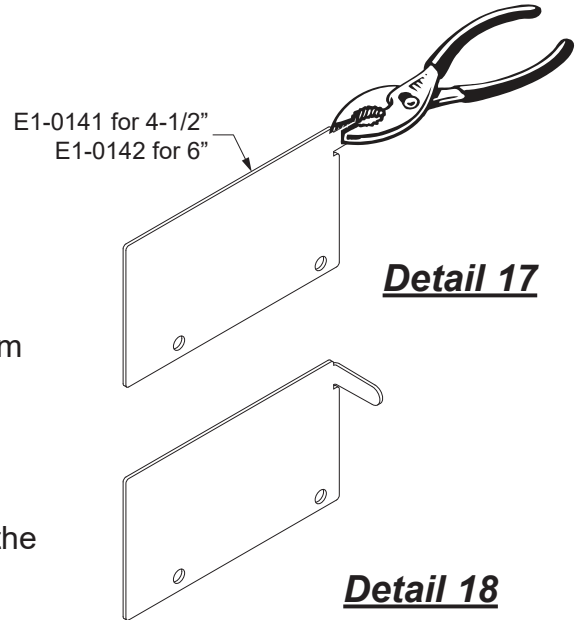

FRAME INSTALLATION

STEP 12
INSTALL SILL FLASHING

- Install the sill flashing with a minimum of 1/4" shim underneath. Sill flashing must be installed level.
- Anchor the sill flashing to the structure a maximum of 4" from each end and then 18" to 24" on center, or per P.E. calculations.
- Apply and tool sealant to cover the heads of all anchor fasteners.
- Remove the nubs with a chisel or pliers on both sides of the splice joint 1-1/2" as shown in **Detail 21**.
- After the sill flashing has been shimmed and installed to the building structure, insert a small backer rod under the sill flashing as shown in **Detail 22**.
- Position the Silicone Splice Sleeve into the front of the channel as shown. Mark and cut the sleeve at this position.
- Clean Sill Flashing and Silicone Splice Sleeve with isopropyl alcohol at the splice location.
- Seal the flashing at the splice location as shown in **Detail 22**, before positioning the flashing. Set the Silicone Splice Sleeve into the sealant.
- Tool sealant tight as shown in **Detail 23** on the next page, squeezing the sheet flat with a seam roller.

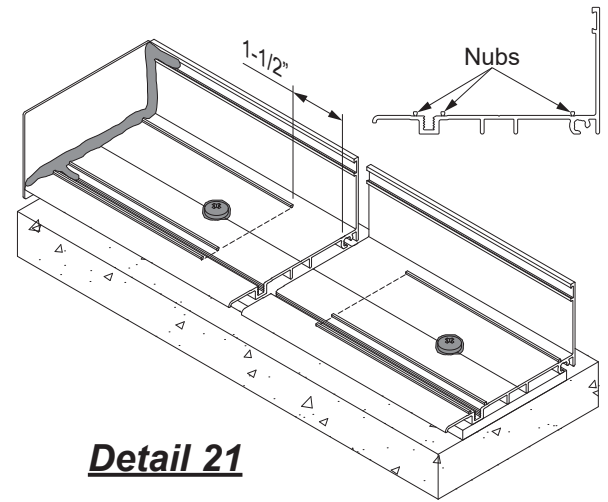

Detail 21

When using E2-0070, a compatible Silicone Sealant must be used at the splice. Compatible Silicone Sealants include Tremco® Spectrum 2 and Dow Corning® 795.

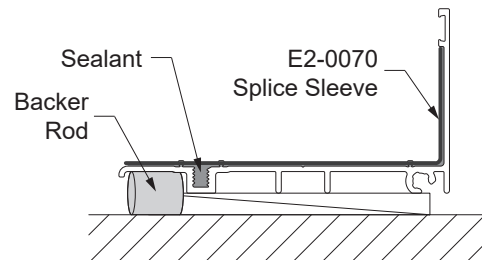
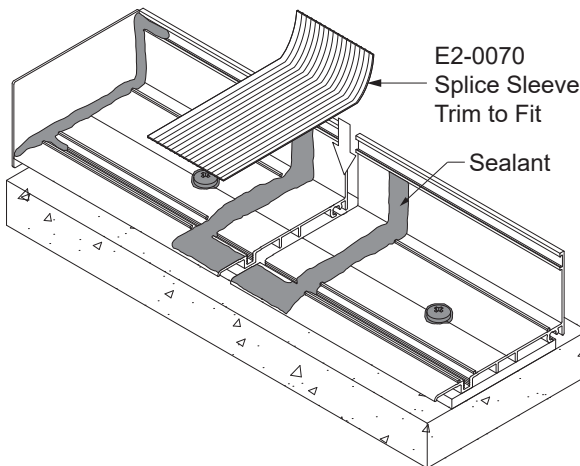

Detail 22

FRAME INSTALLATION

**STEP 12 (Continued)
INSTALL SILL FLASHING**

-Apply masking tape to the back of the sill flashing at the splice as shown in **Detail 23**.

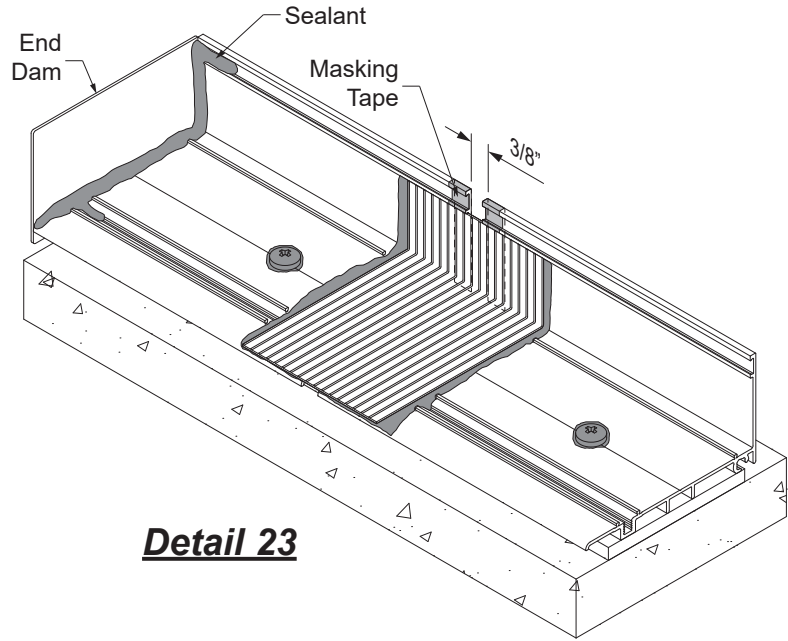

Detail 23

**STEP 13
SILL PREPARATION**

-At every splice condition, apply bond breaker tape to the back of the sill member before the joint is sealed between the sill and the sill flashing.

See **Detail 24**.

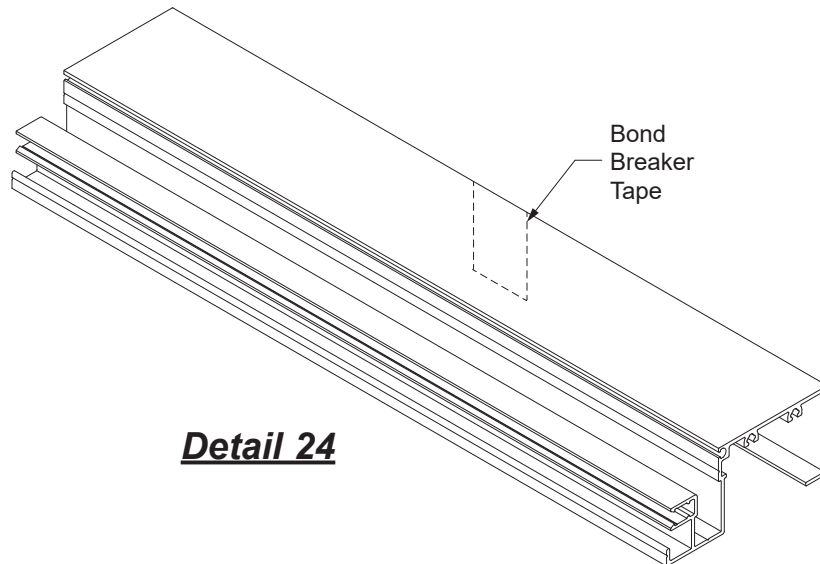

Detail 24

FRAME INSTALLATION

STEP 14
INSTALL SILL FLASHING

- Cut two 12" long pieces of sill flashing E9-1868 / E9-1869 and miter (45° for 90° corner and 67.5° for 135° corners.)
- Align the two pieces at the corner condition with the mitered ends pushed together tight and anchor the sill flashing as called out on the shop drawings.
- Apply and tool sealant to the mitered joint and anchor heads.

See **Detail 25**.

- Continue installing the rest of the sill flashing providing a 3/8" joint at the splices as shown in **Step 12** on **Page 19**.

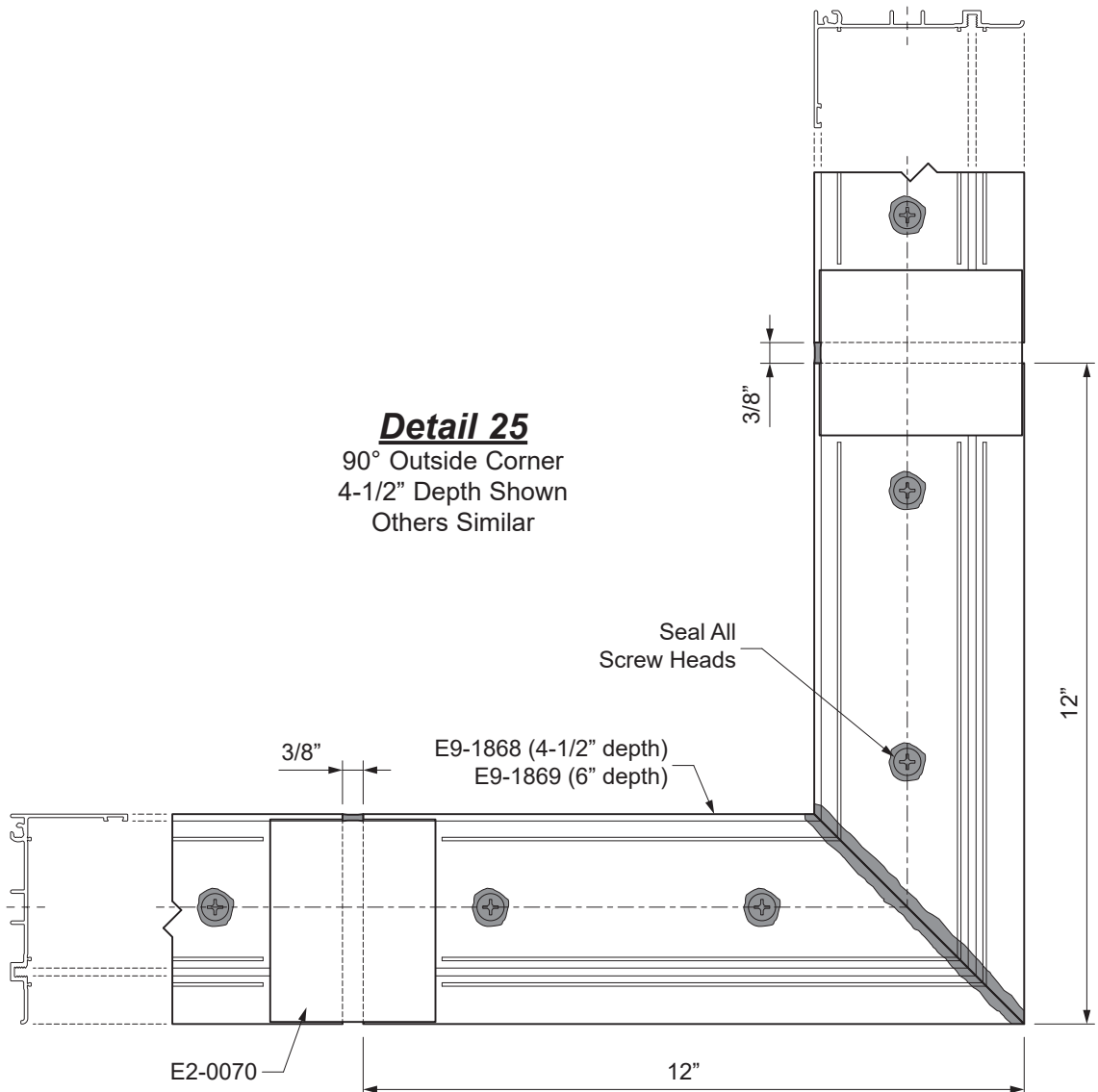

FRAME INSTALLATION

STEP 15 INSTALL FRAMES

- Immediately before installing the frames, apply a continuous bead of sealant to the back leg of the sill flashing. Make sure all surfaces are clean.
- Snap frame assemblies together and set onto the sill flashing.
- Shim the head and jamb members to ensure that the frame is installed plumb, square, and true.
- Anchor the frame to the structure through the glazing pocket of the perimeter members:
 - Head and sill members: 3" on each side of all verticals and then no more than 18" on center.
 - Jamb members: 3" from each end and then no more than 18" on center.
- Seal all anchor heads.

See **Detail 26**.

Note: Shims must be installed at all anchor points. Anchor size and location should be determined by a qualified engineer.

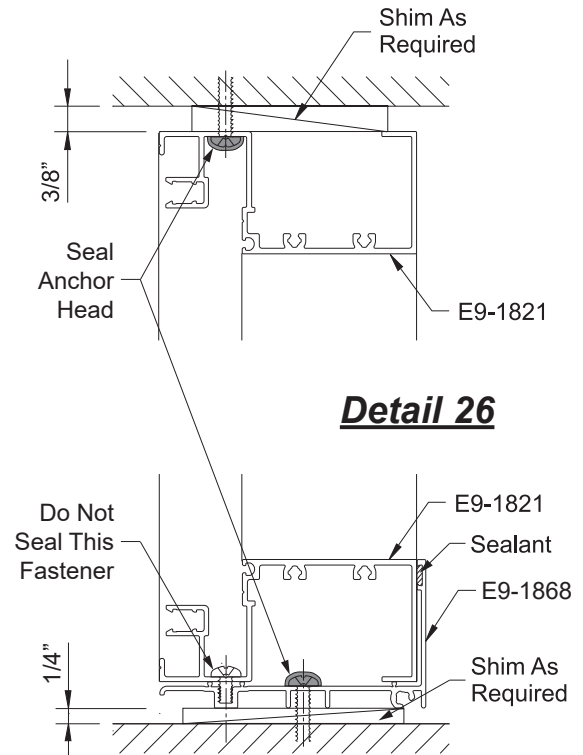

Detail 26

FRAME INSTALLATION

**STEP 16
SEAL DOOR JAMB TO SILL FLASHING**

Prior to snapping the assembled frames into the door jamb, the end of the sill flashing needs to be sealed to the door jamb.

- Apply and tool sealant to all sill flashing to door jamb joints.
- Apply sealant to completely fill the door jamb cavity and ramp the sealant down onto the sill flashing.

See **Detail 27**.

Refer to the **20D, 35D, & 50D Entrances Installation Manual** for door installation instructions.

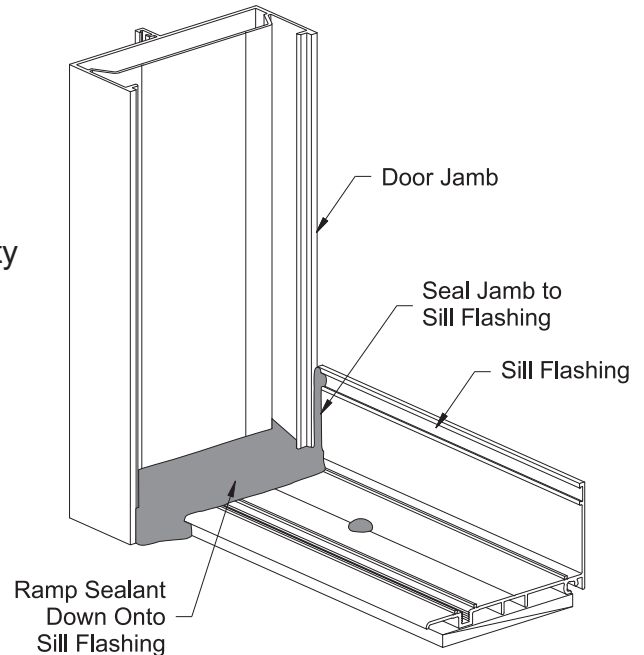

Detail 27

**STEP 17
APPLY INTERNAL SEALANT**

- Apply a non-hardening sealant to all vertical to horizontal joints.
- Apply a non-hardening sealant to all exposed fastener heads.
- Tool the sealant to ensure a water tight seal.

See **Detail 28**.

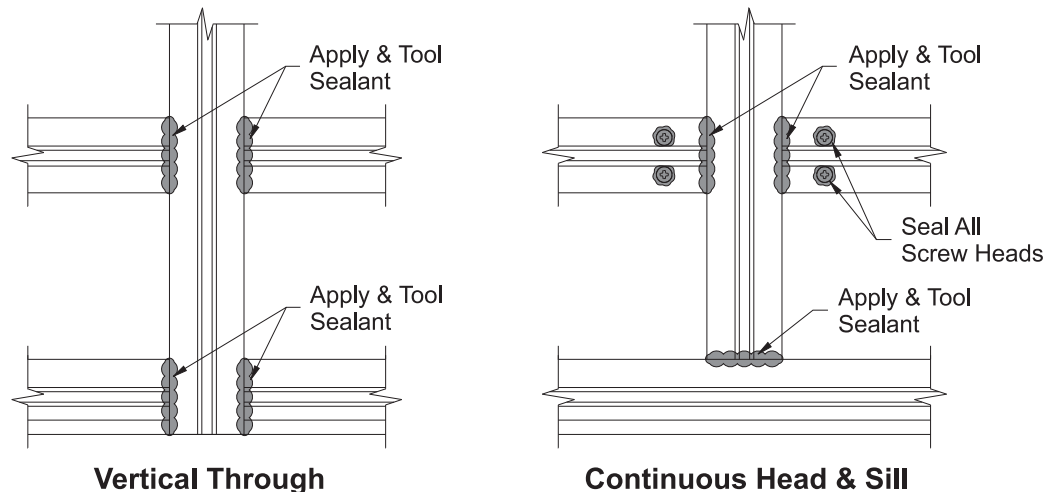

Detail 28

FRAME INSTALLATION

STEP 18 INSTALL JOINT PLUGS AT INTERMEDIATE HORIZONTALS

- Each end of the horizontal tongue must be sealed to the vertical using joint plugs, E2-0208.
 - Apply sealant to the three contact sides of the joint plug and install it over the tongue of the horizontal.
 - Tool the excess sealant up and over the joint plug to form a watertight joint.
- See **Detail 29**.

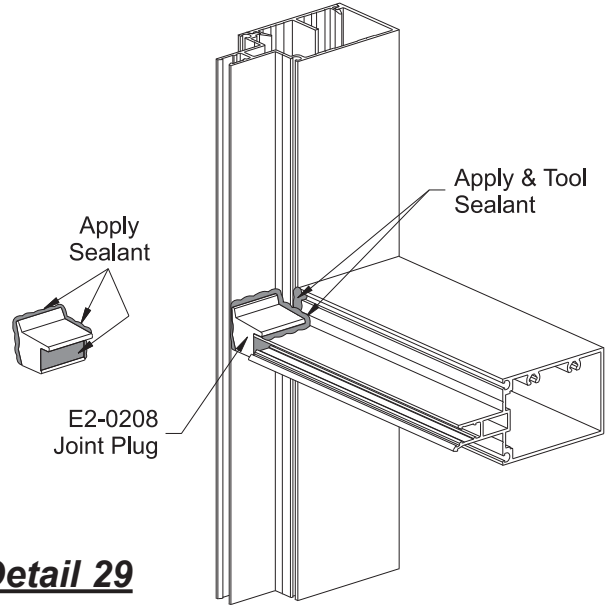

Detail 29

STEP 19 INSTALL WATER DEFLECTORS AT SSG VERTICALS

YES 600 requires the installation of water deflector, E1-1032, to bridge the gap between intermediate horizontals at the SSG vertical.

- Clean and dry off the glazing pocket of each horizontal at the ends.
 - Apply sealant to the bottom side of the water deflector on both ends as shown in **Detail 30**.
 - Install the water deflector centered over the opening between the two horizontals.
 - Apply and tool sealant along the vertical and horizontal behind the water deflector.
 - Tool the excess sealant up and over the edges of the water deflector.
- See **Detail 30**.

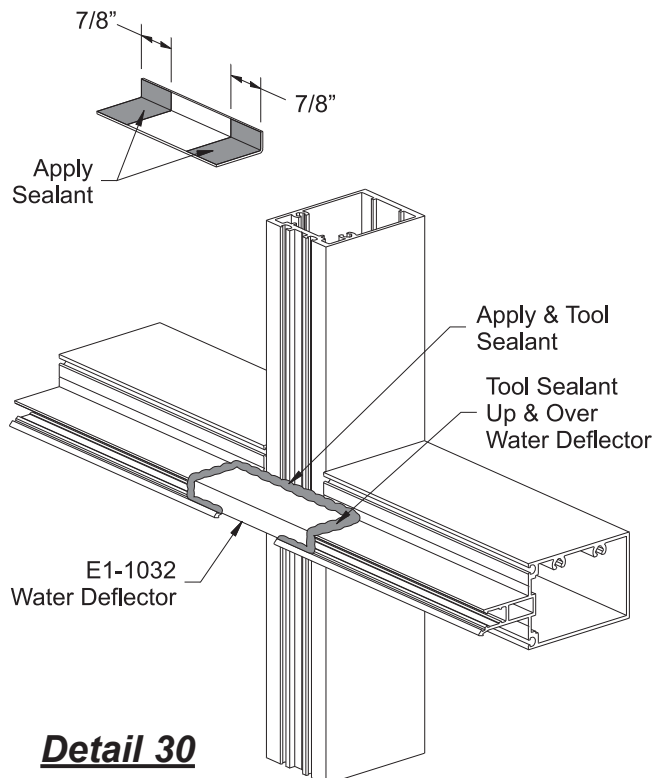

Detail 30

FRAME INSTALLATION

**STEP 20
APPLY PERIMETER SEALANT**

- Install backer rod around the perimeter of the frame.
 - Apply perimeter sealant to the joint between the frame and the structure on the exterior and interior.
- See **Detail 31**.

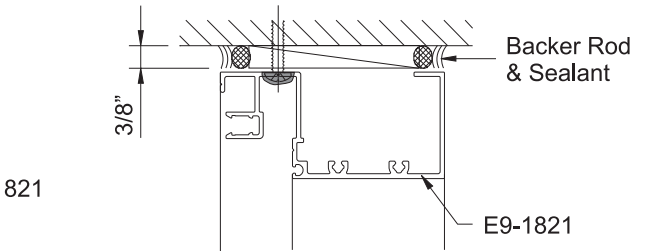
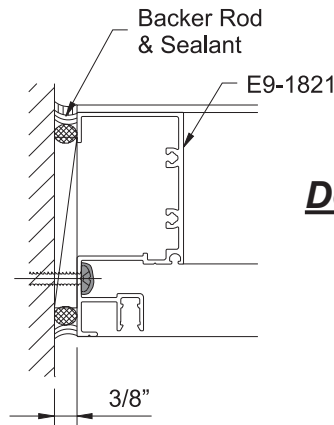

Detail 31

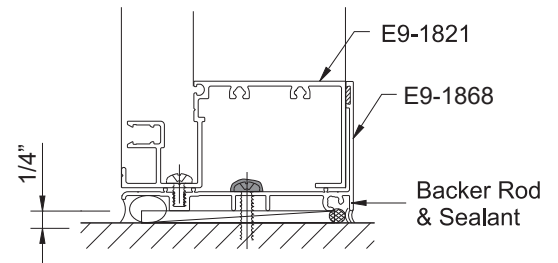

**STEP 21
INSTALL 1/4" GLAZING ADAPTORS
(When Required)**

- Run a bead of sealant along the gasket reglets of the members that the adaptor will attach to.
- Attach vertical adaptors first:

- Center the vertical adaptor in the opening and match drill the mullion using a 0.161" diameter (#20) drill bit through the holes previously drilled in **Step 6**.
- Attach the adaptor using a PC-1006 fastener at each end.

Attach horizontal adaptors:

- Dry fit the horizontal adaptors between the vertical adaptors and match drill the mullion using a 0.161" diameter (#20) drill bit.
- Remove the adaptor and apply sealant to each end of the adaptor.
- Reattach the adaptor to the mullion using a PC-1006 fastener at each end.

- Seal all screw heads.

See **Detail 32**.

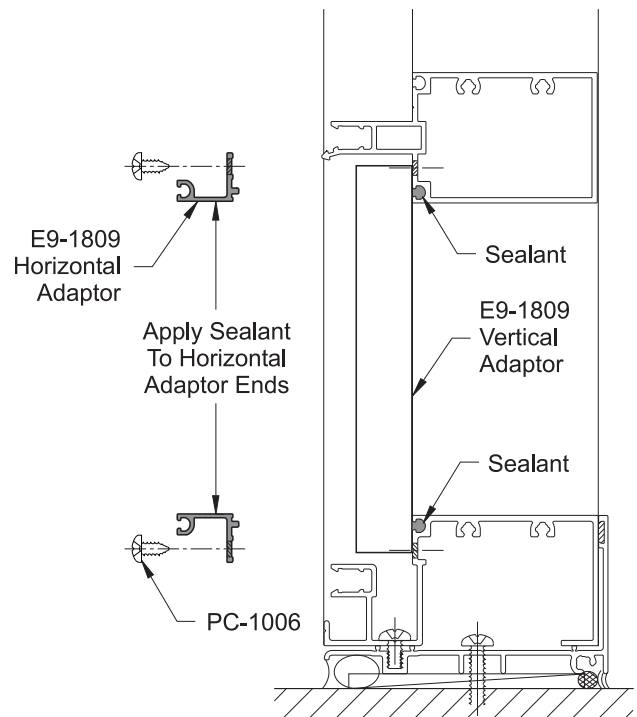

Detail 32

GLAZING

STEP 22 GLAZING STANDARD FRAMES

- Cut interior vertical gaskets to Daylight Opening plus(+) 1-1/4".
- Cut interior horizontal gaskets to Daylight Opening plus(+) 3/16" for each foot of horizontal.
- Apply sealant into the gasket reglets one to two inches in each direction of the corner.
- Install vertical gaskets first centered along the opening.
- Apply sealant to each end of the horizontal gasket prior to inserting into the reglet.
- Insert the gasket at each end first and then at the midpoint of the opening.
- Push the gasket into the reglet starting at the midpoint and work towards each end.
- Tool the excess sealant at the gasket corners to ensure a watertight seal.

- Cut water deflector gasket, E2-0254, to the daylight opening plus(+) 1-3/16".
- Snap the water deflector onto the bottom of the horizontal mullion tongue centered across the opening.

- Install glazing clips, E3-0015, into the mullion tongues of all framing members:
A maximum of 3" from each end and no more than 9" on center thereafter.

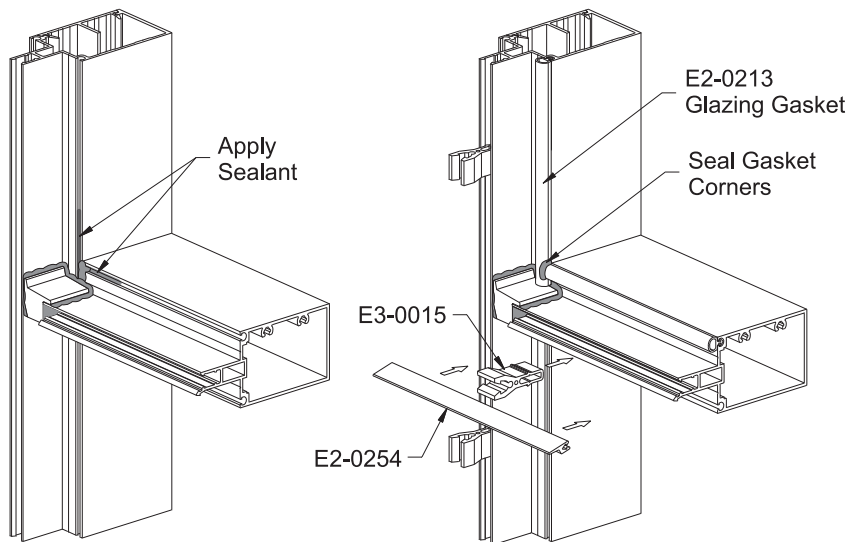

Detail 33

See **Detail 33**.

For Continuous Head & Sill Frames Only

- In order for the frame to weep moisture to the exterior properly, exterior glazing gaskets E2-0213 cannot run continuously along the bottom of the sill face cover.
- Mark the centerlines of weep holes along the sill face cover.
- Leave 1/2" gaps between the gasket at weep hole centerlines.

See **Detail 34**.

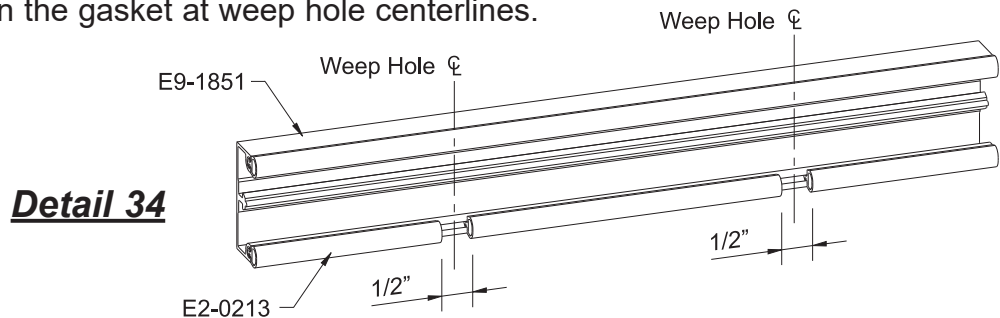

Detail 34

GLAZING

STEP 22 (Continued)
GLAZING STANDARD FRAMES

-Determine the glass size:

	Width	Height
Standard Glazing	D.L.O. + 7/8"	D.L.O. + 7/8"

-Install setting blocks at 1/4 points or according to engineering calculations.

At intermediate horizontals: E2-0202.

At sills: E2-0253.

-Attach side blocks, E2-0133, to all jambs and captured verticals at the midpoint of the vertical daylight opening.

-Carefully install glass into the frame making sure that it is properly aligned with setting and side blocks.

See **Detail 35**.

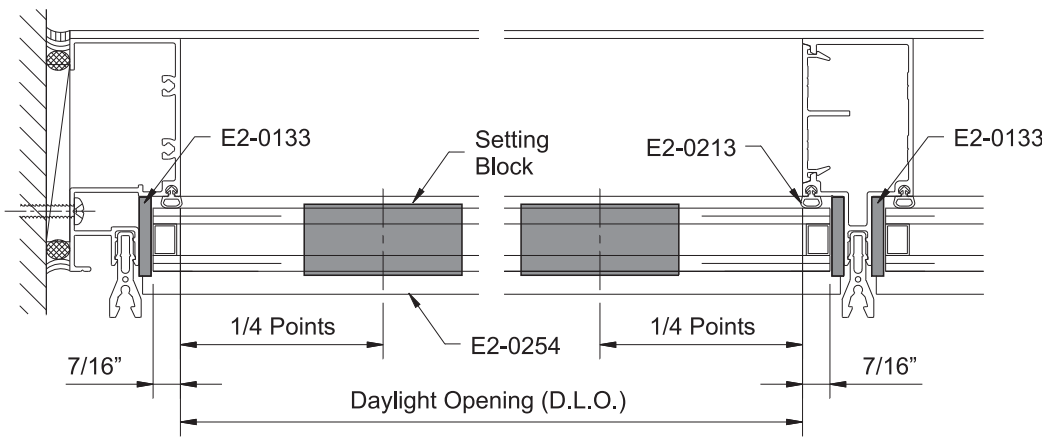
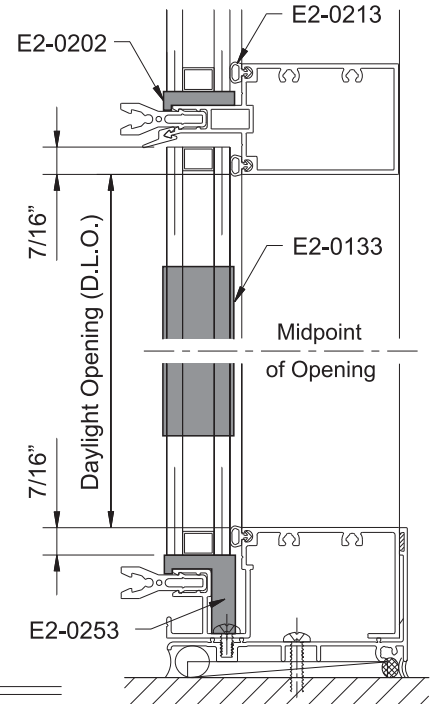

Detail 35

-Cut vertical exterior gaskets to the length of the vertical face covers.

-Cut horizontal exterior gaskets to the length of the horizontal face covers plus 3/16" for every foot of horizontal.

-Insert gaskets into the face covers.

-Using a wooden block and a rubber mallet, attach the face covers to the glazing clips. Vertical face covers must be attached first.

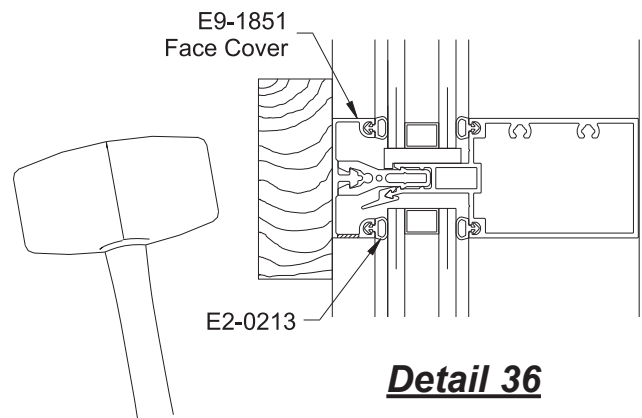

Detail 36

See **Detail 36**.

GLAZING

STEP 23

GLAZING STRUCTURAL SILICONE GLAZED (SSG) FRAMES

- Cut glazing spacer (E2-0214 for SSG mullions or Norton V-2100 glazing tape for SSG expansion mullions) to Daylight Opening plus(+) 1”.
 - Cut interior horizontal gaskets to Daylight Opening plus(+) 1/4” for each foot of horizontal.
 - Cut interior vertical gaskets for jamb members to Daylight Opening plus(+) 1”.
 - Install glazing spacers or glazing tape first centered along the opening.
 - Insert the horizontal gasket at each end first and then at the midpoint of the opening.
 - Push the gasket into the reglet starting at the midpoint and work towards each end.
- See **Detail 37**.

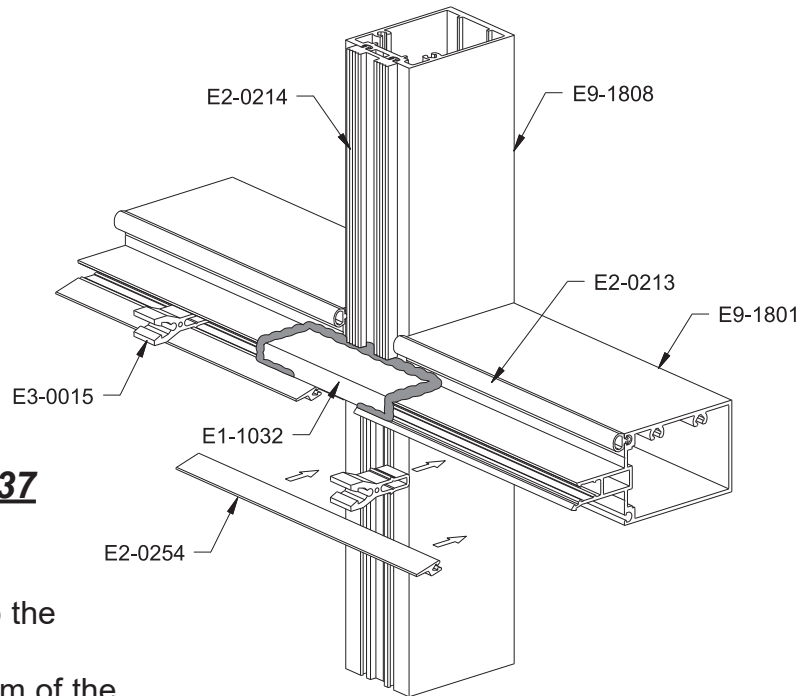

Detail 37

- Cut water deflector gasket, E2-0254, to the daylight opening plus(+) 1-3/16”.
 - Snap the water deflector onto the bottom of the horizontal mullion tongue centered across the opening.
 - Install glazing clips, E3-0015, into the mullion tongues of all head, horizontal, sill, and jamb members:
A maximum of 3” from each end and no more than 9” on center thereafter.
- See **Detail 37**.

For Continuous Head & Sill Frames Only

- In order for the frame to weep moisture to the exterior properly, exterior glazing gaskets E2-0213 cannot run continuously along the bottom of the sill face cover.
 - Mark the centerlines of weep holes along the sill face cover.
 - Leave 1/2” gaps between the gasket at weep hole centerlines.
- See **Detail 34** on **Page-26**.

GLAZING

STEP 23 (Continued)
GLAZING STRUCTURAL SILICONE GLAZED (SSG) FRAMES

-Determine the glass size:

	Width	Height
Jamb to SSG	D.L.O. + 1-1/8"	D.L.O. + 7/8"
SSG to SSG	D.L.O. + 1-3/8"	D.L.O. + 7/8"

-Install setting blocks at 1/4 points or according to engineering calculations.

At intermediate horizontals: E2-0202.
At sills: E2-0253.

- Attach side blocks, E2-0133, to all jambs at the midpoint of the vertical daylight opening.
 - Carefully install glass into the frame making sure that it is properly aligned with setting and side blocks.
- See **Detail 38**.

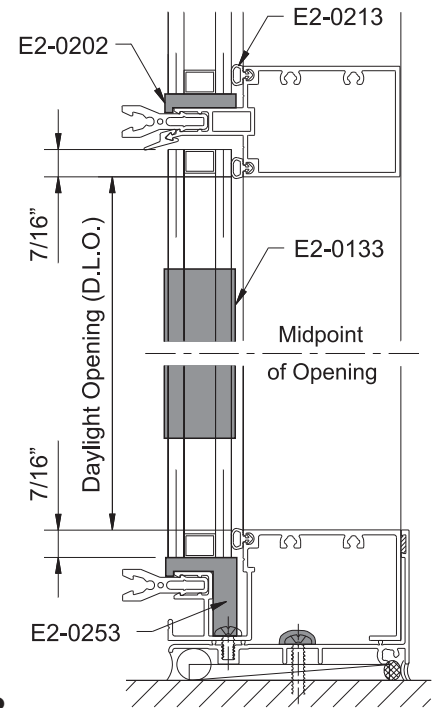

Detail 38

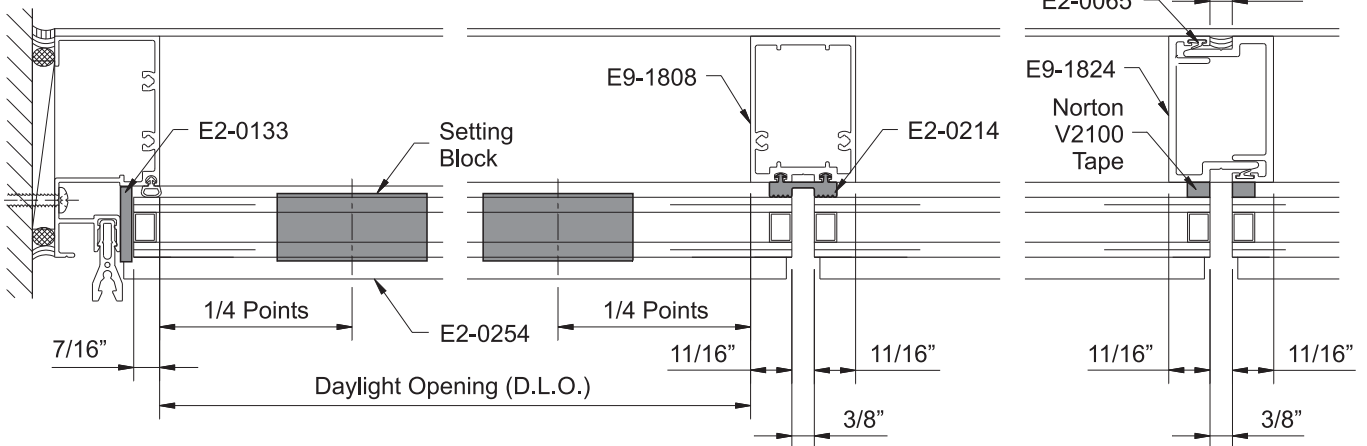

Temporary glass retainers, E1-1033, must be attached to all SSG mullions:

- Attach temporary glass retainers a maximum of 2'-0" on center with #10 – 40 Tek fasteners.

See **Detail 39**.

- Cut vertical exterior gaskets to the length of the vertical face covers plus(+) 1".
- Cut horizontal exterior gaskets to the length of the horizontal face covers plus 1/4" for every foot of horizontal.

Detail 39

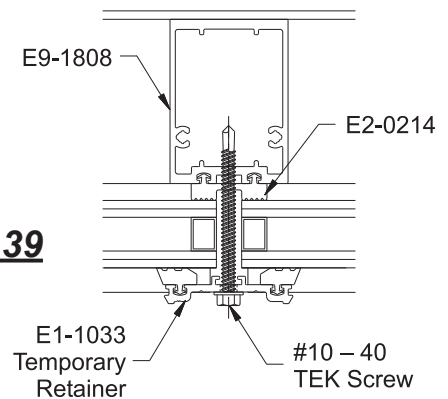

GLAZING

STEP 23 (Continued)

GLAZING STRUCTURAL SILICONE GLAZED (SSG) FRAMES

- Insert gaskets into the face covers.
 - Using a wooden block and a rubber mallet, attach the face covers to the glazing clips.
- See **Detail 40**.

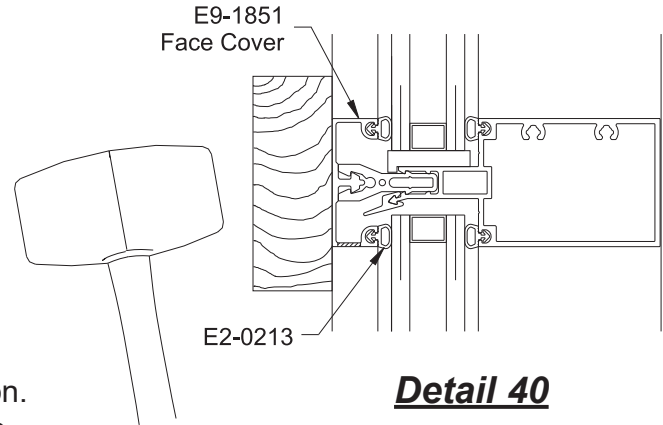

Apply Interior Structural Silicone

- Clean all surfaces with an approved cleaner.
- Apply masking tape to the mullion aligned with the edge of the glazing pocket; apply masking tape to the glass aligned with the edge of the mullion.
- Apply a quality structural silicone from the bottom to the top of the joint using positive pressure to completely fill the cavity between the glass and the SSG mullion.
- Using a non-scratching implement, tool the silicone immediately after running the joint.
- Exert positive pressure while tooling to ensure that the silicone completely fills the cavity; be careful not to remove too much silicone. The finished joint should be flush with the edge of the SSG mullion.

See **Detail 41**.

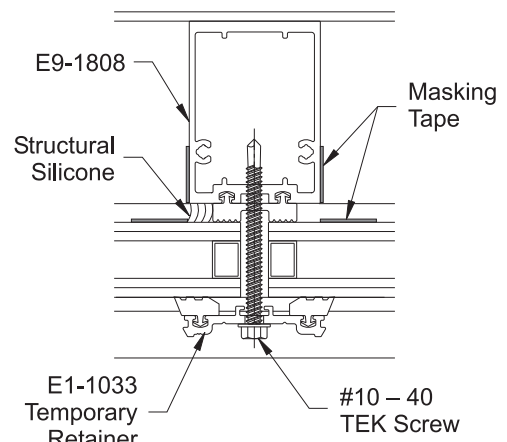

Apply Exterior Structural Silicone Weatherseal

- Once the interior structural silicone has cured, consult silicone manufacturer for curing time, remove the temporary glass retainers.
- Insert an approved backer rod between the two lites.
- Clean all surfaces with an approved cleaner and apply masking tape to both vertical edges of the glass.
- Starting at the bottom, apply an approved silicone to the joint between the lites using positive pressure to ensure that the cavity is completely filled.
- Using a non-scratching implement, tool the silicone immediately after running the joint.
- Exert positive pressure while tooling to ensure that the silicone completely fills the cavity; be careful not to remove too much silicone. The finished joint should be flush with the edge of the SSG mullion.

See **Detail 42**.

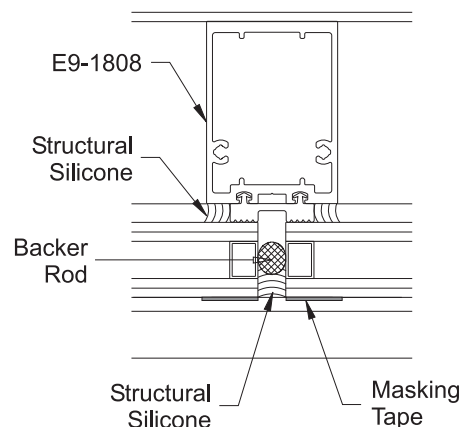

Caution: Do not permit the silicone to skin over before tooling. Immediately remove tape after tooling the silicone.



101 Marietta Street NW
Suite 2100
Atlanta, Georgia 30303
www.ykkap.com