

Window Products



Maintenance Manual

TABLE OF CONTENTS

Maintenance Notes.....	Page ii
INSTALLATION	Pages 1 & 2
ROUTINE ALUMINUM CLEANING INSTRUCTIONS	Page 3
ROUTINE GLASS CLEANING INSTRUCTIONS	Page 4
GLASS REMOVAL / REPLACEMENT	Pages 5 & 6
YKK AP WINDOW MAINTENACE CHECKLIST	Pages 7 to 9
LIMIT DEVICE REMOVAL / RE-ATTACHMENT	Page 10

MAINTENANCE NOTES

The purpose of this manual is to provide guidance to building maintenance personnel with regard to inspection and upkeep of the YKK AP window products.

Over the lifetime of a window product, it is possible that parts can become damaged. During the active warranty period, the installer of the YKK AP windows should be contacted if replacement parts are needed. Beyond the warranty period, please contact YKK AP or your local YKK AP representative about obtaining replacement parts.

INITIAL INSPECTION

All window frames must be installed plumb, level, and square.

Perimeter Caulk Beads

-Window frame perimeter caulk beads are required on the exterior only of all windows. Interior caulk bead is optional.

Note: If sill flashing is used, interior caulk bead is required.

-Perimeter caulk beads should be continuous and should be applied in accordance with the sealant manufacturer's application instructions.

See **Detail 1**.

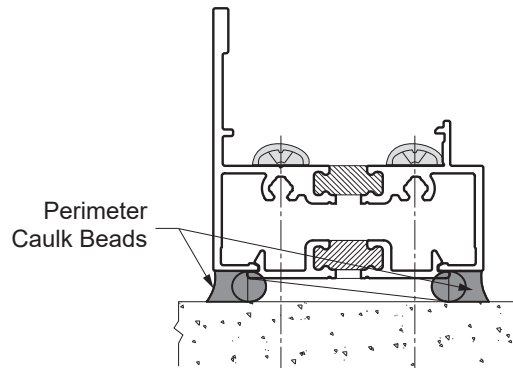

DETAIL 1

Operable glazed window sashes or vents should be square and should fit in their frames plumb, level, and square.

- All hardware should be firmly attached to the frames and sashes or vents.
- Operable window products must be closed and all locks secured for the window to meet air, water, structural, thermal, and/or impact/blast performance requirements.
- All debris should be removed from the window frame and vent or sash perimeters in order to allow windows to close properly and to ensure that frame moisture drainage can occur. Frame and vent or sash perimeter bulb gaskets and/or weatherseals should also be free from debris to ensure proper sealing of the vent or sash to the frame when closed.

INITIAL INSPECTION (Continued)

- Exterior silicone cap seals between the glass and the frame/vent/sash should be continuous and should demonstrate continuous adhesion to the glass and the frame/vent/sash. There should be no pin holes in the exterior silicone cap seal.
- Interior glass stops should be firmly seated in place with no more than 1/16" between the cut ends of the horizontal and the vertical glass stops.
- All interior gasket ends should fit tightly at the corners. Interior wedge glazing gaskets should be firmly seated between the interior glazing beads and the glass.

See **Detail 2**.

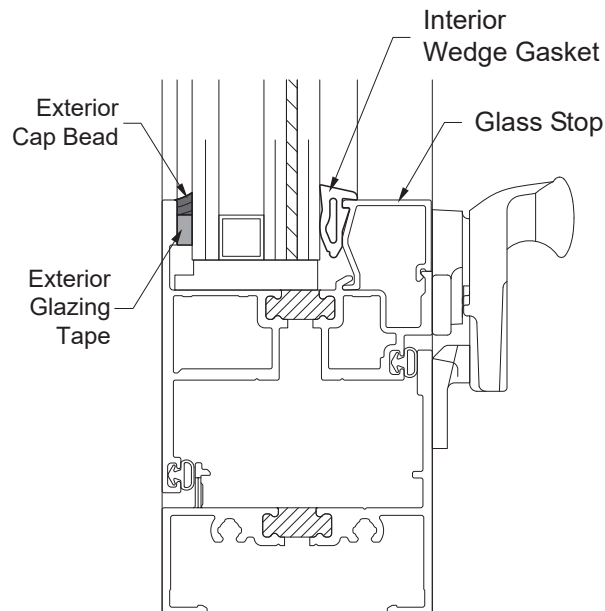

DETAIL 2

Window operation (unlocking, opening, closing, and securing) should be smooth.

ROUTINE ALUMINUM CLEANING INSTRUCTIONS

YKK AP architectural aluminum products are provided as specified with either an anodized finish or a fluoropolymer type painted finish. Both finishes are extremely durable, but they do require routine cleaning to protect the finish from damage and to ensure long-term attractiveness.

YKK AP recommends that care and cleaning of its architectural aluminum finishes be performed in accordance with the AAMA 609 & 610 Cleaning and Maintenance Guide for Architecturally Finished Aluminum. YKK AP cannot distribute copies of AAMA documents, so it is recommended that your building maintenance staff obtain a copy of this document from AAMA. AAMA documents can be purchased on the AAMA website at www.aamanet.org.

The amount of contaminant buildup on the aluminum and glass can vary depending on environmental conditions. Frequent rainfall can help lessen the need for cleaning, but marine conditions, pollution, smog, etc. can increase the need for cleaning. The cleaning frequency can be as often as once per month or as little as once per year.

Whenever the glass is cleaned, it is advisable to also clean the aluminum window frames immediately after the glass. Contaminants from the glass cleaning process should not be allowed to damage the aluminum frame finish.

Light surface soil can be removed from anodized or painted finishes with moderate water pressure and mild soaps and detergents, such as Dawn or Joy. Follow by rinsing with clean water.

For heavier soil on anodized finishes, wet the surface then rub the surface with a non-abrasive pad and mild detergent, such as Dawn or Joy. Always rub with the grain of the anodized aluminum. Follow by rinsing with clean water.

For heavier soil on fluoropolymer type painted finishes, mild solvents such as mineral spirits or mild detergents should be used sparingly with a clean non-abrasive cloth. Follow by rinsing with clean water.

ROUTINE GLASS CLEANING INSTRUCTIONS

Glass cleaning frequency need can also vary with enviromental conditions. It is recommended that aluminum frames should be cleaned immediately after the glass is cleaned.

Uncoated glass surfaces can be cleaned with mild soaps or high quality glass cleaning solution applied with non-abrasive pads or cloths. The surface should then be rinsed and wiped with a clean commercial squeegee. Care should be taken to not damage the exterior silicone cap bead with tools or abrasives.

If the glass has an exposed coating surface, it should be cleaned in accordance with the glass manufacturer's recommendations.

If plastic infill is used in lieu of glass, it should be cleaned in accordance with the infill manufacturer's recommendations.

GLASS REMOVAL / REPLACEMENT

If it becomes necessary to replace lites of glass, the windows can be de-glazed and re-glazed.

Standard Glass Re-Glazing

-The exterior cap bead and glazing tape act as adhesives and sealants so they must be cut in order to remove the glass.

If interior preset gaskets are used:

-Remove the glass stops by prying up with a putty knife pressed into the seam between the glass stop and the vent frame. The preset gasket should be saved for re-glazing.

If interior wedge gaskets are used:

-The interior wedge gasket can be pulled out.

-After the wedge gasket is removed, the glass stops can be removed by rotating them towards the glass and prying up with a putty knife pressed into the seam between the glass stop and the vent frame.

-All traces of the old tape and the silicone cap bead should be cleaned off of the frame prior to re-glazing.

See **Detail 3**.

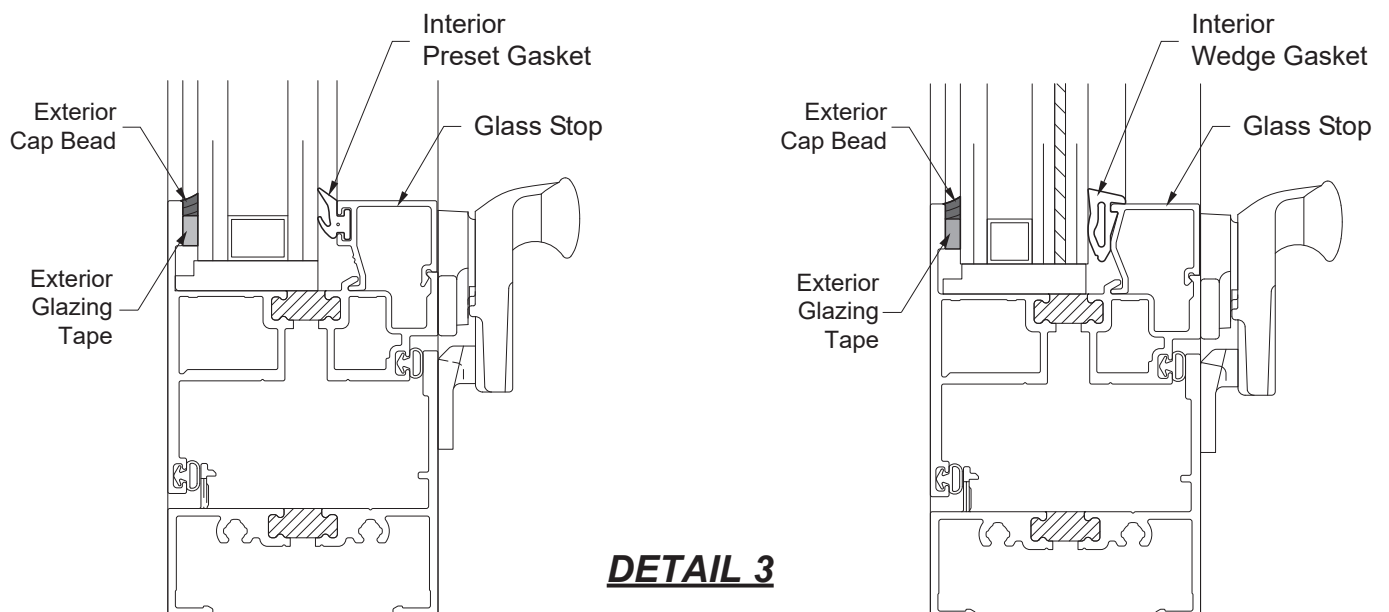

After de-glazing and vent cleaning have been performed, please refer to the YKK AP Installation Instructions for the specific window product in use for proper glazing instruction.

GLASS REMOVAL / REPLACEMENT (Continued)

Large Missile Impact Glass Re-Glazing

- The exterior cap bead and glazing tape act as adhesives and sealants so they must be cut in order to remove the glass.
- The interior structural silicone must also be cut and removed.
- After the interior structural silicone is removed, the snap cover can be removed by prying with a putty knife.
- After the snap cover trim is removed, the glass stop can be removed by unscrewing the fasteners that hold it in place.
- After the glass stop is removed, the spacer can be pulled out and the glass removed. The spacer should be saved for re-glazed.
- All traces of the old tape, silicone cap bead, and structural silicone should be cleaned off of the frame prior to re-glazing.

See **Detail 4**.

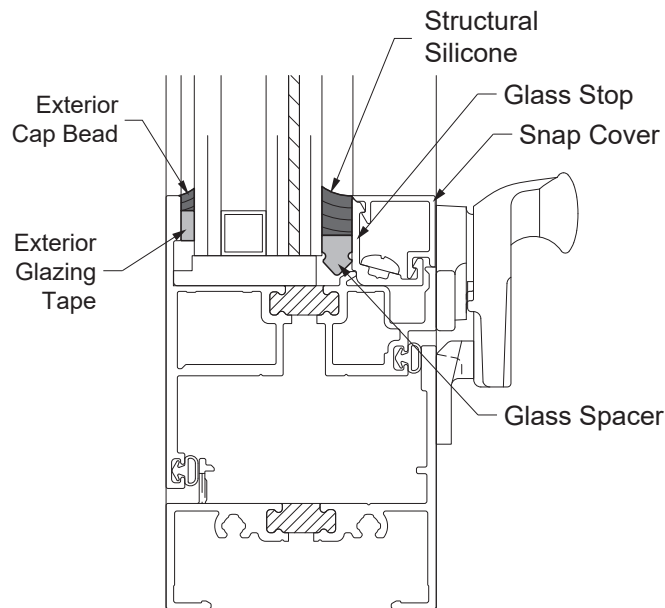

DETAIL 4

After de-glazing and vent cleaning have been performed, please refer to the YKK AP Installation Instructions for the specific window product in use for proper glazing instruction.

YKK AP WINDOW MAINTENANCE CHECKLIST

Regular maintenance will keep your windows operating smoothly and maintain your warranty. The checklist below is an annual maintenance reminder.

Note: This schedule may need to be adjusted if the atmospheric or coastal conditions dictate a more frequent inspection and cleaning.

GENERAL

- Inspect the exterior caulking around the outer edges of the window frame. Trim off any old or loose caulking and seal any gaps with new sealant.
- Clean any sand, dirt, debris or dust from window hinges, sills and tracks. On hung or sliding windows, after cleaning, apply a small amount of Dry Film Lubricant (Loctite Moly Dry, DuPont Teflon Stick or 3 -IN-ONE Dry Lube), to the track surfaces. DO NOT use a petroleum-based lubricant.
- Clean the exposed hardware using mild soaps or detergents (Dawn or Joy) and a soft, non-abrasive cloth or pad. DO NOT use steel wool or strong or abrasive commercial or house hold cleaners.
- Clean the window frame and sash/vent using mild soaps or detergents (Dawn or Joy) and a soft, non-abrasive cloth or pad. DO NOT use steel wool or strong or abrasive commercial or house hold cleaners.
- Moving parts do not require lubrication. Lubrication is generally not recommended as many lubricants can trap dirt and debris. If you feel that you need lubricate moving/pivoting points, use of a Dry Film type lubricant is recommended. DO NOT use a petroleum-based lubricant.
- Check that all hardware (locks, opening mechanisms, etc.) operates smoothly.
- Make sure any exposed hardware screws are tightened securely. Fasteners should be inspected at least once a year to ensure they remain tight. If any fasteners become loose, they should be tightened using hand tools only such as a screw driver or Allen wrenches, depending on the fastener type. DO NOT USE POWER TOOLS. Aggressive over-tightening can strip the fasteners.
- Hardware adjustment over time should not be necessary if the windows are initially installed correctly. If it is determined that adjustment is required to relocate keepers or other items, fasteners can be loosened and hardware items moved slightly to improve alignment.

YKK AP WINDOW MAINTENANCE CHECKLIST (Continued)**WEATHER SEALS****For Hung & Sliding type Windows**

-Weather-strip is a polypropylene, fin type material designed to act as a barrier in the space between the sliding sash and frame to reduce air and water infiltration. Make sure it is still effective. Replace any worn, torn or weather-beaten weather-stripping.

For Casements & Awning type Windows

-Compression or Air Tight gaskets are a thermal plastic, rubbery type material designed to act as a barrier when compressed in the space between the vent and frame to reduce air and water infiltration. Make sure it is still effective. Replace any worn, torn or dried & compressed gaskets.

PANELS

-Check energy panels and storm and screen combinations to make sure screws in turn buttons or anti-lift out devices are securely fastened.

GLASS

-In general, all glass can be cleaned with any high quality commercial or household glass cleaning solution. However, if your glass is coated or has film installed on the glass, it is recommended that you contact the supplier or manufacturer of the coating/film for an approved cleaning solution.

If replacement parts are needed, please contact your local YKK AP representative or your local YKK AP distributor for assistance.

ACCESSIBLE WINDOWS

These recommended maintenance items are based on the atmospheric or coastal conditions and building settlement.

-In addition to the general items on **Page-7**: To maintain the compliance of the window, additional inspection, cleaning, and adjustments will be necessary. If the building has settled, or if you have replaced hardware, then post-installation adjustment may be required. Refer to Locking Bar and Keeper Adjustment instruction on the next page.

YKK AP WINDOW MAINTENANCE CHECKLIST (Continued)

ACCESSIBILITY LOCKING HARDWARE ADJUSTMENT

Tools Required:

3/16" Hex Key for E1-2001 Base Bar or E1-2002 Extension Bar

#2 Phillips Screw Driver for E1-1751 Keeper Screw

Caution: Never use a power screw driver to adjust and/or replace hardware components.

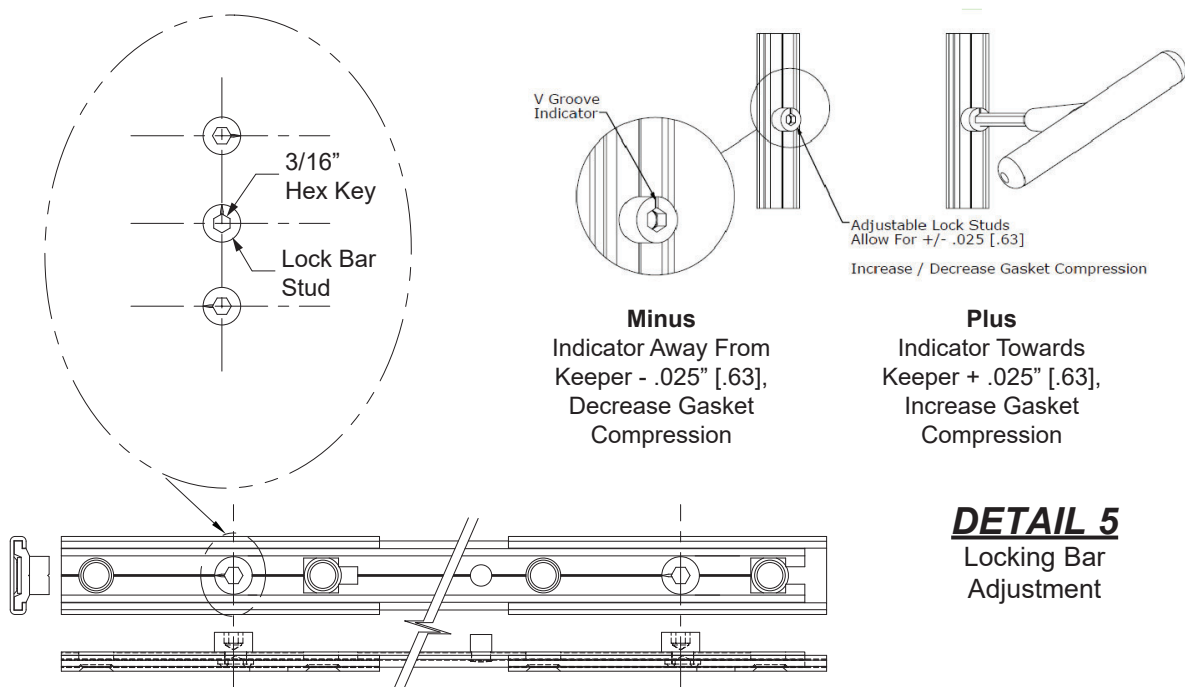

DETAIL 5

Locking Bar Adjustment

-Once the tracks of all the operating parts have been thoroughly cleaned of all dirt and debris, you may wish to lubricate them with a small amount of Dry Film Lubricant, such as Loctite Moly Dry, Dupont Teflon Stick or 3-IN-1 Dry Lubricant.

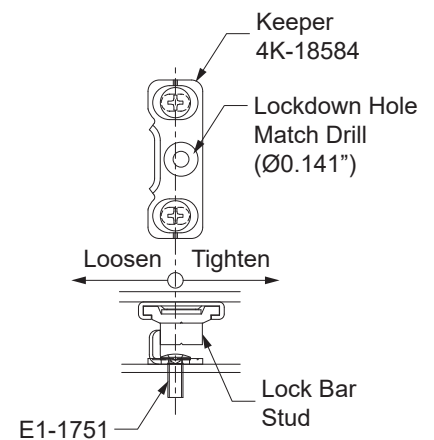

DETAIL 6

Keeper Adjustment

LIMIT DEVICE REMOVAL / RE-ATTACHMENT

Keyed limit devices (E1-1904 or E1-1975) must be in their secure position at all times to function properly. Removal and re-attachment of limit devices for maintenance purposes (using an E1-1907 key) should be performed only by trained personnel. The procedure is illustrated below in **Detail 7**. The re-attachment procedure is the reverse of removal.

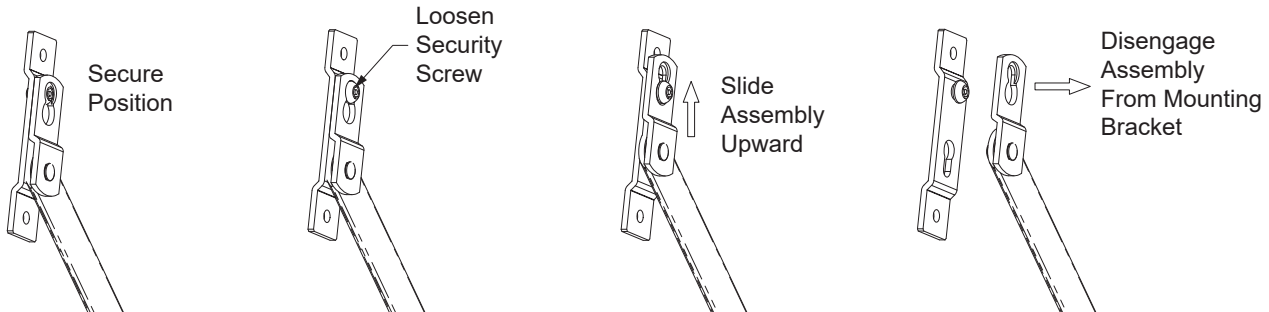
**DETAIL 7**



101 Marietta Street NW
Suite 2100
Atlanta, Georgia 30303
www.ykkap.com