

TABLE OF CONTENTS

**YOW 225 TU THERMAL OPERABLE WINDOWS
2-1/4" DEPTH**

YOW 225 TU WINDOW VARIATIONS	Page 2
YOW 225 TU STANDARD WINDOW CONFIGURATIONS	Pages 3 & 4
YOW 225 TU FIXED WINDOW DETAILS (1/2 SIZE).....	Page 5
YOW 225 TU CASEMENT OUTSWING/INSWING DETAILS (1/2 SIZE)	Page 6 to 15
YOW 225 TU PROJECT OUT/IN DETAILS (1/2 SIZE).....	Pages 16 to 22
YOW 225 TU ACCESSIBLE WINDOW HARDWARE OPTIONS	Pages 23 to 26
YOW 225 TU ACCESSIBLE WINDOW SCREEN OPTIONS.....	Pages 27 to 29
YOW 225 TU ANCHORING OPTIONS.....	Pages 30 & 31
YOW 225 TU SILL FLASHING & SILL TRIM DETAILS	Pages 32 & 33
YOW 225 TU MULLION OPTIONS	Pages 34 to 36
YOW 225 TU MULLION DESIGN PRESSURES.....	Pages 37 to 39
YOW 225 TU SCREEN OPTIONS & DETAILS.....	Pages 40 to 48
YOW 225 TU TECHNICAL NOTES	Pages 49 to 56
YOW 225 TU HARDWARE GUIDE.....	Pages 57 & 58

*The latest installation instructions for this product are available at www.ykkap.com.

YOW 225 TU WINDOW VARIATIONS

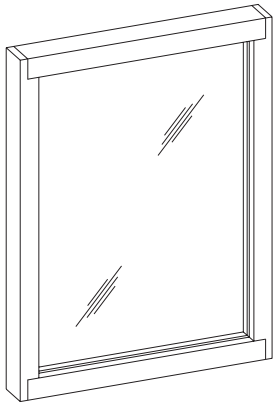

FIXED

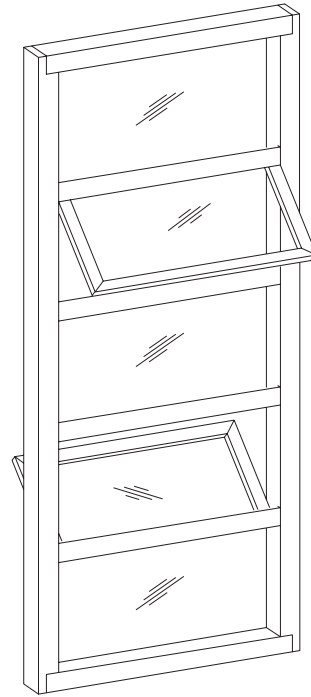

**PROJECT
IN/OUT SWING**

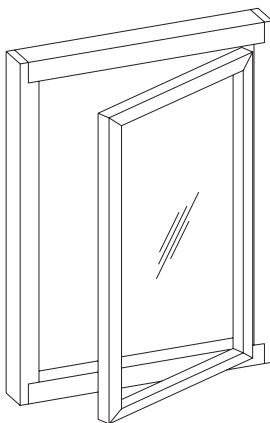

**CASEMENT
OUTSWING**

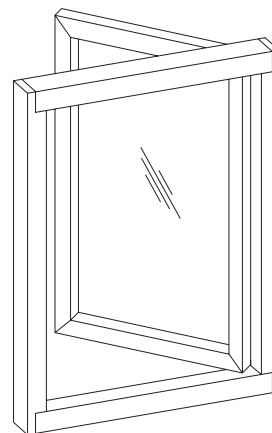

**CASEMENT
INSWING**

YOW 225 TU STANDARD WINDOW CONFIGURATIONS

FIXED

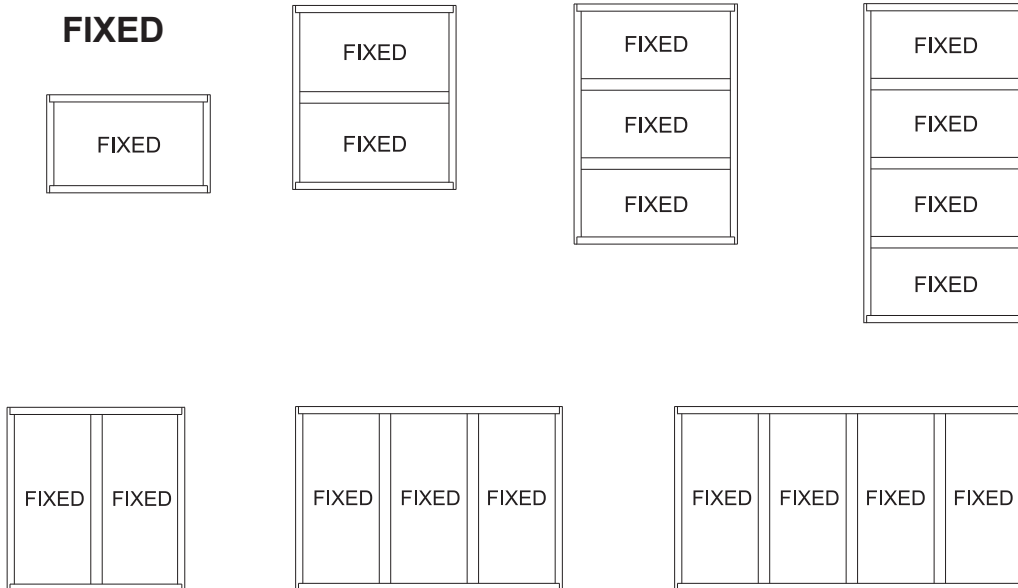

CASEMENT OUTSWING

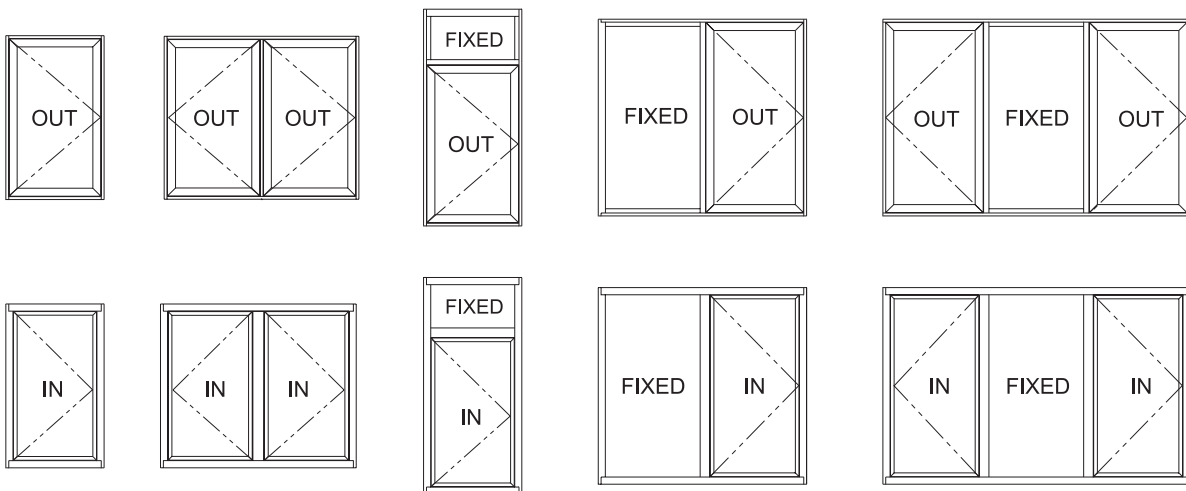

CASEMENT INSWING

YOW 225 TU STANDARD WINDOW CONFIGURATIONS

MASTER FRAME

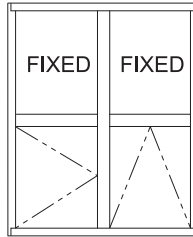

With optional vents. Contact YKK-AP for more information.

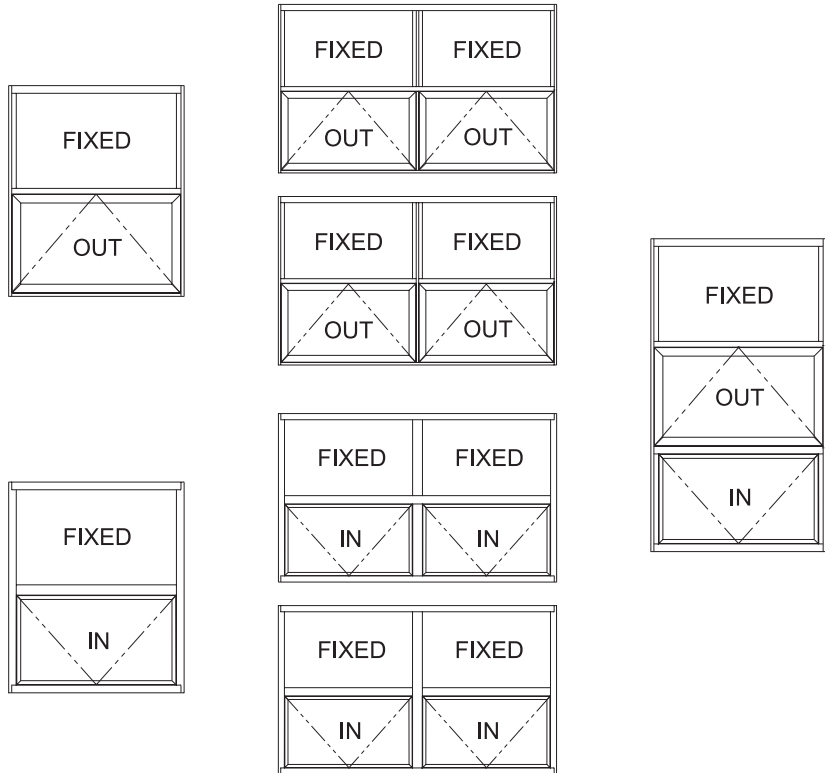
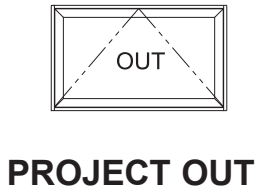

YOW 225 TU FIXED
1" Glazing

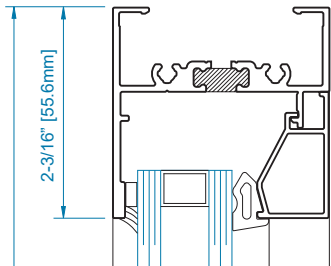
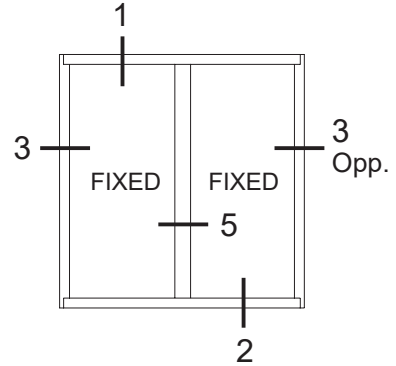
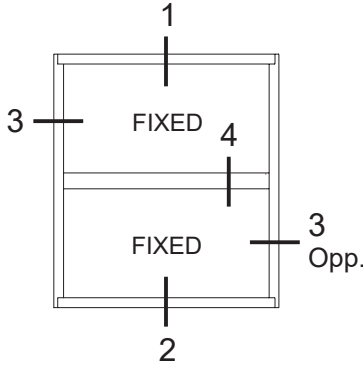
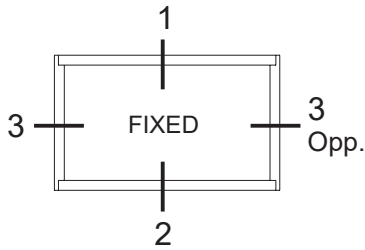

SECTION 1

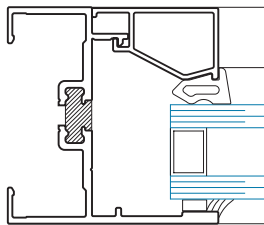

SECTION 3

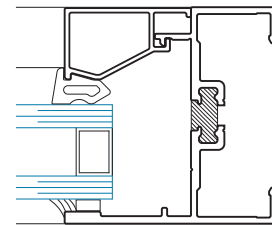

SECTION 3 Opp.

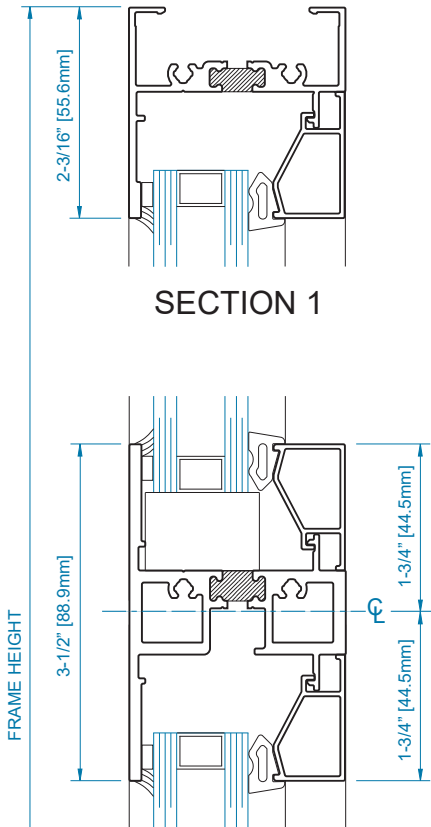

SECTION 4

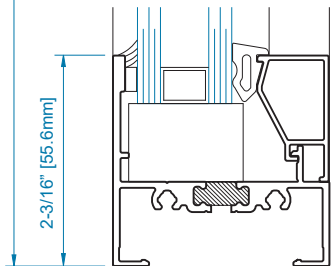

SECTION 2

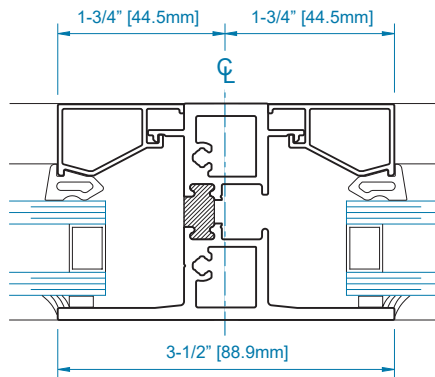

SECTION 5

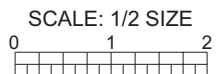

**YOW 225 TU CASEMENT OUTSWING
1" Glazing**

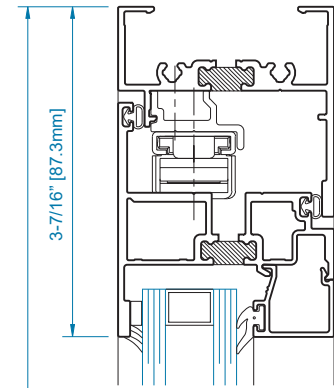

SECTION 6

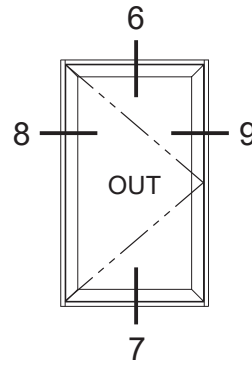

FRAME HEIGHT

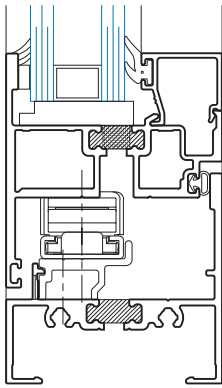

SECTION 7

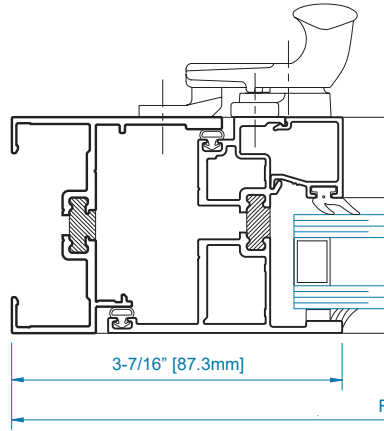

SECTION 8

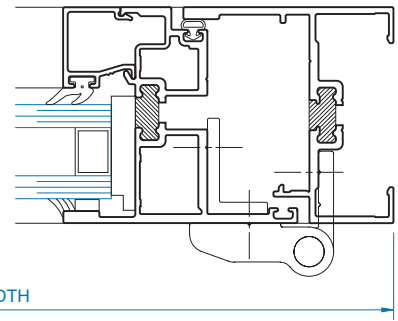

**SECTION 9
w/ Optional Butt Hinge**

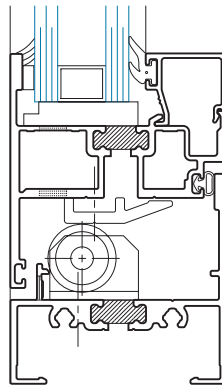

**SECTION 7A
With Optional
Guide Roller**

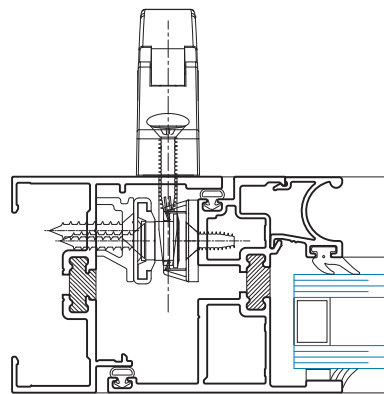

**SECTION 8A
With Optional
Multi-Lock Handle**

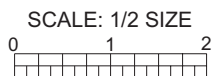

YOW 225 TU DOUBLE CASEMENT OUTSWING
1" Glazing

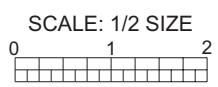
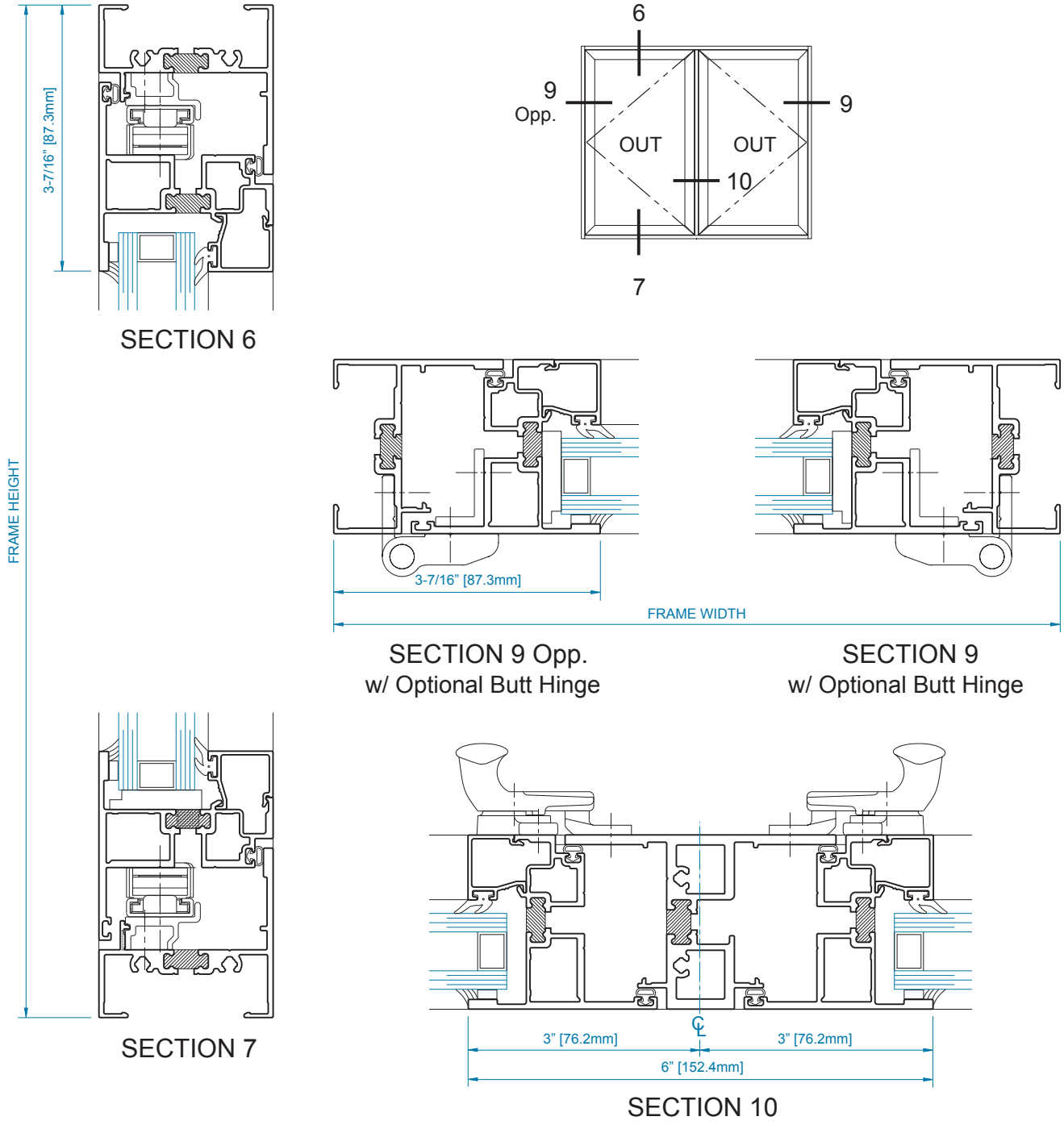

YOW 225 TU FIXED/CASEMENT OUTSWING 1" Glazing

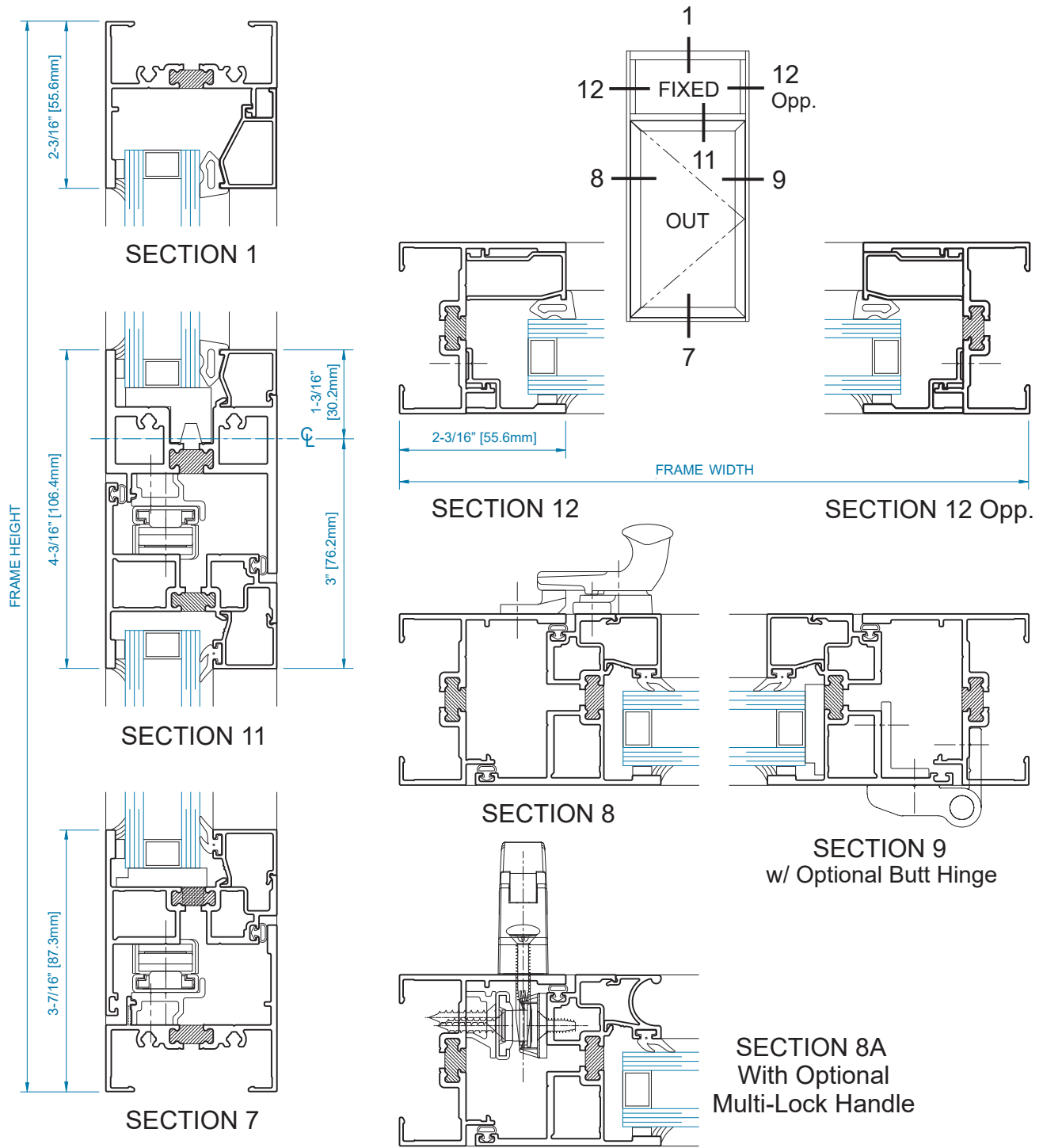

YOW 225 TU FIXED-CASEMENT OUTSWING
1" Glazing

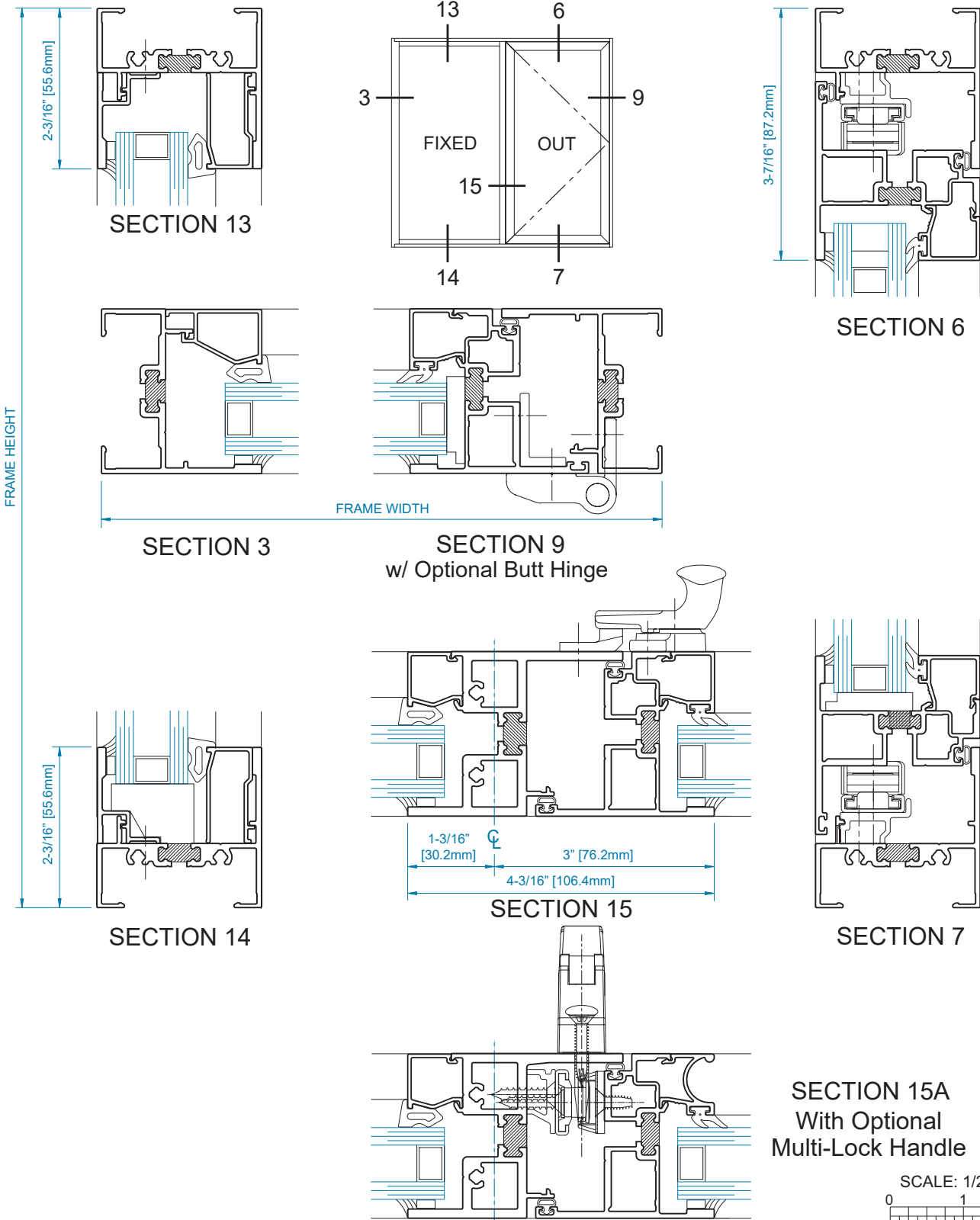

YOW 225 TU CASEMENT OUTSWING-FIXED-CASEMENT OUTSWING 1" Glazing

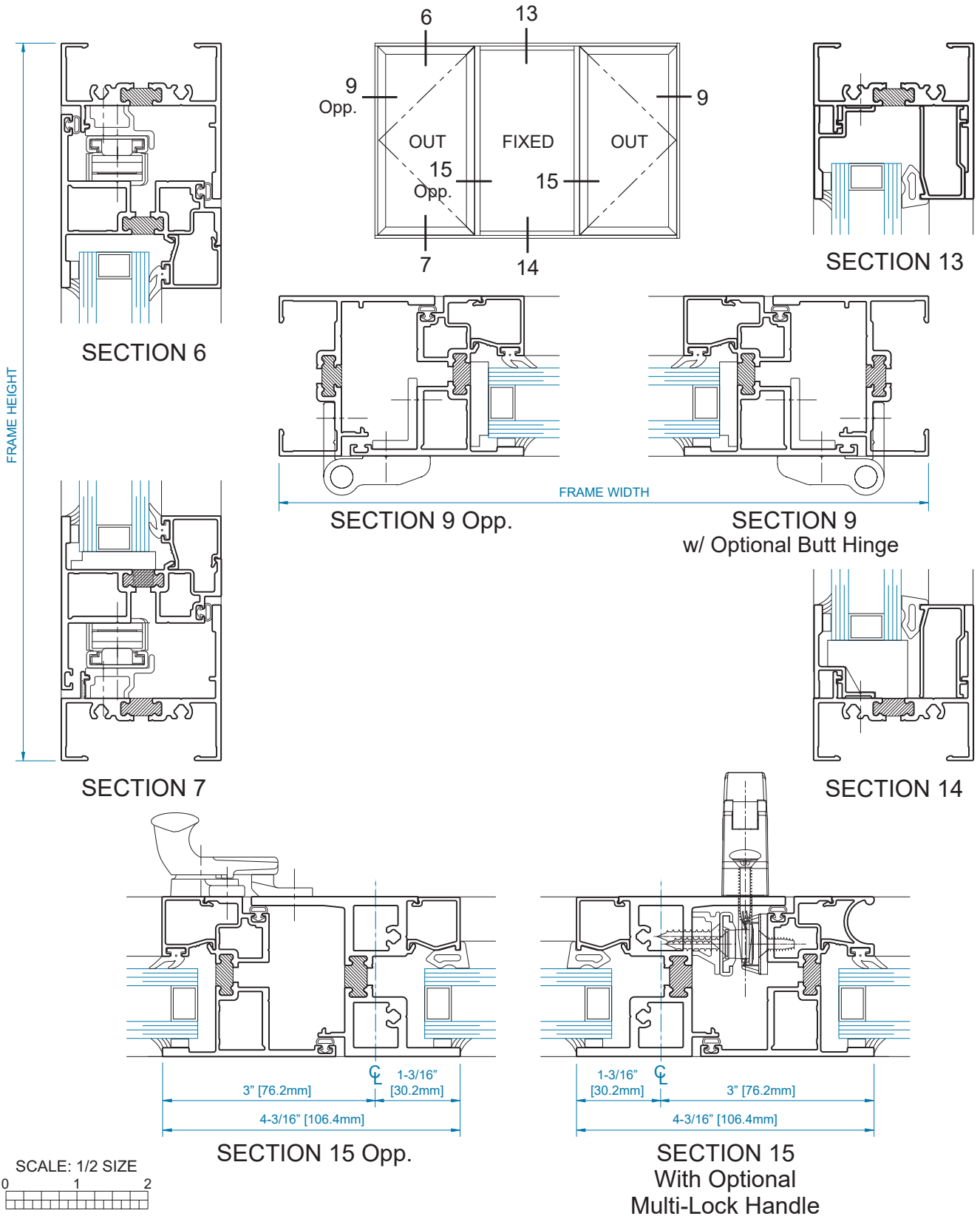

**YOW 225 TU CASEMENT INSWING
1" Glazing**

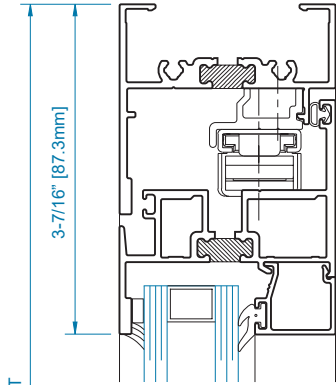

SECTION 16

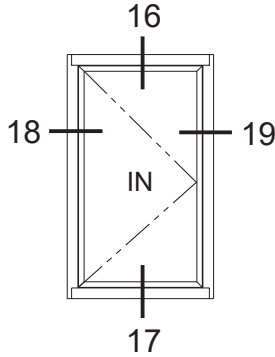

FRAME HEIGHT

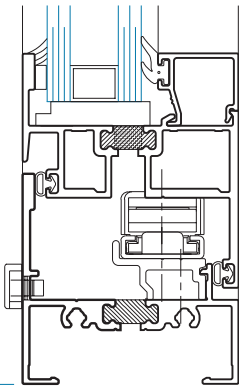

SECTION 17

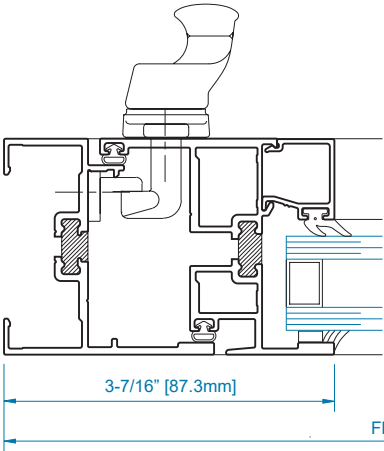

SECTION 18

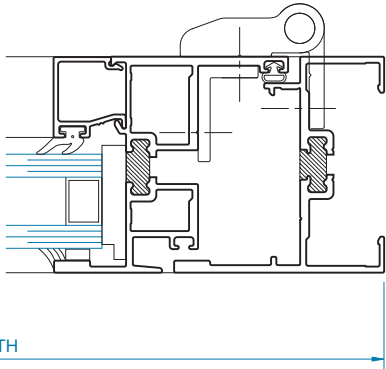

SECTION 19
w/ Optional Butt Hinge

FRAME WIDTH

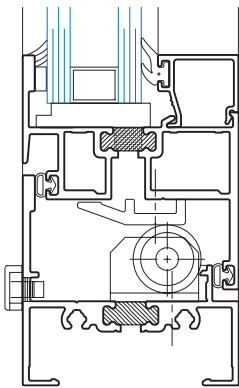

SECTION 17A
With Optional
Guide Roller

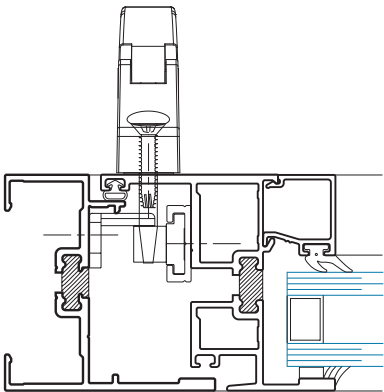

SECTION 18A
With Optional
Multi-Lock Handle



YOW 225 TU DOUBLE CASEMENT INSWING 1" Glazing

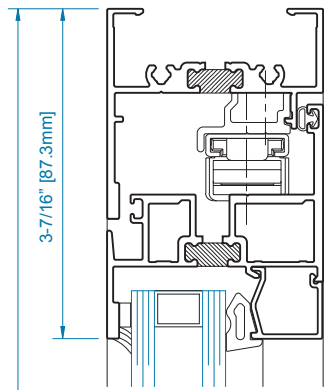

SECTION 16

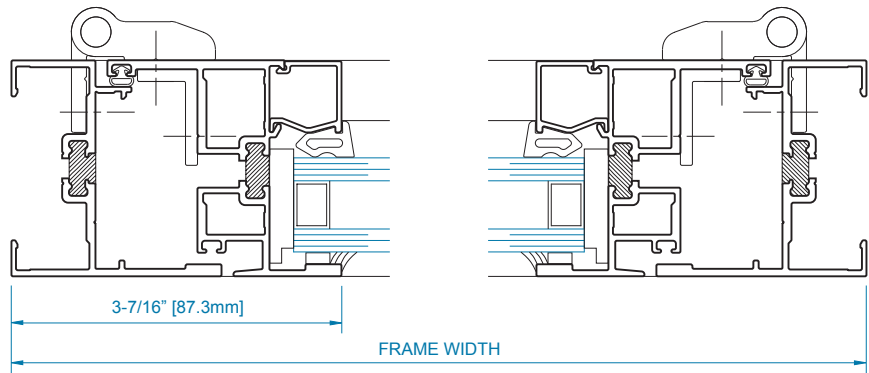
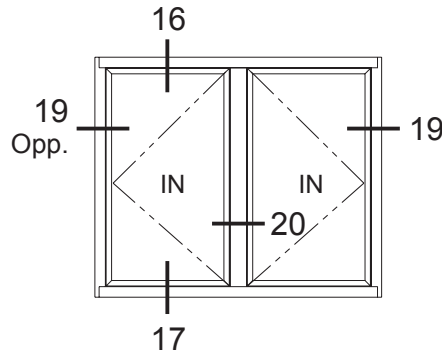

SECTION 19 Opp.
w/ Optional Butt Hinge

SECTION 19
w/ Optional Butt Hinge

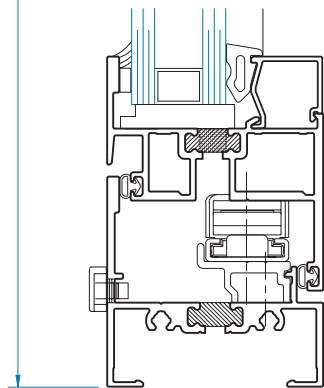

SECTION 17

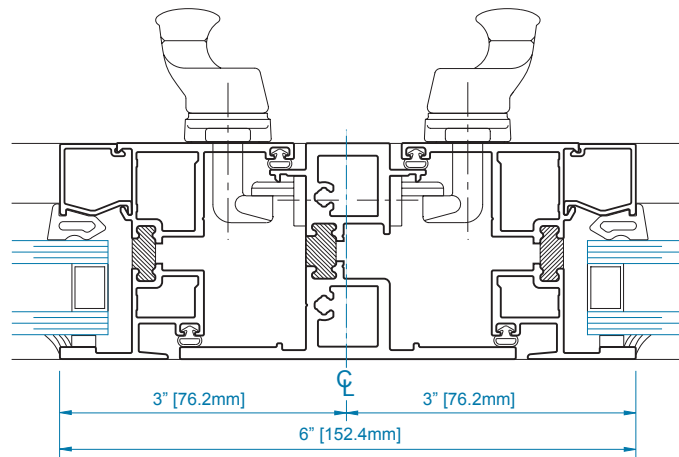

SECTION 20

SCALE: 1/2 SIZE



YOW 225 TU FIXED/CASEMENT INSWING
1" Glazing

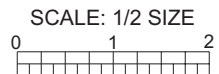
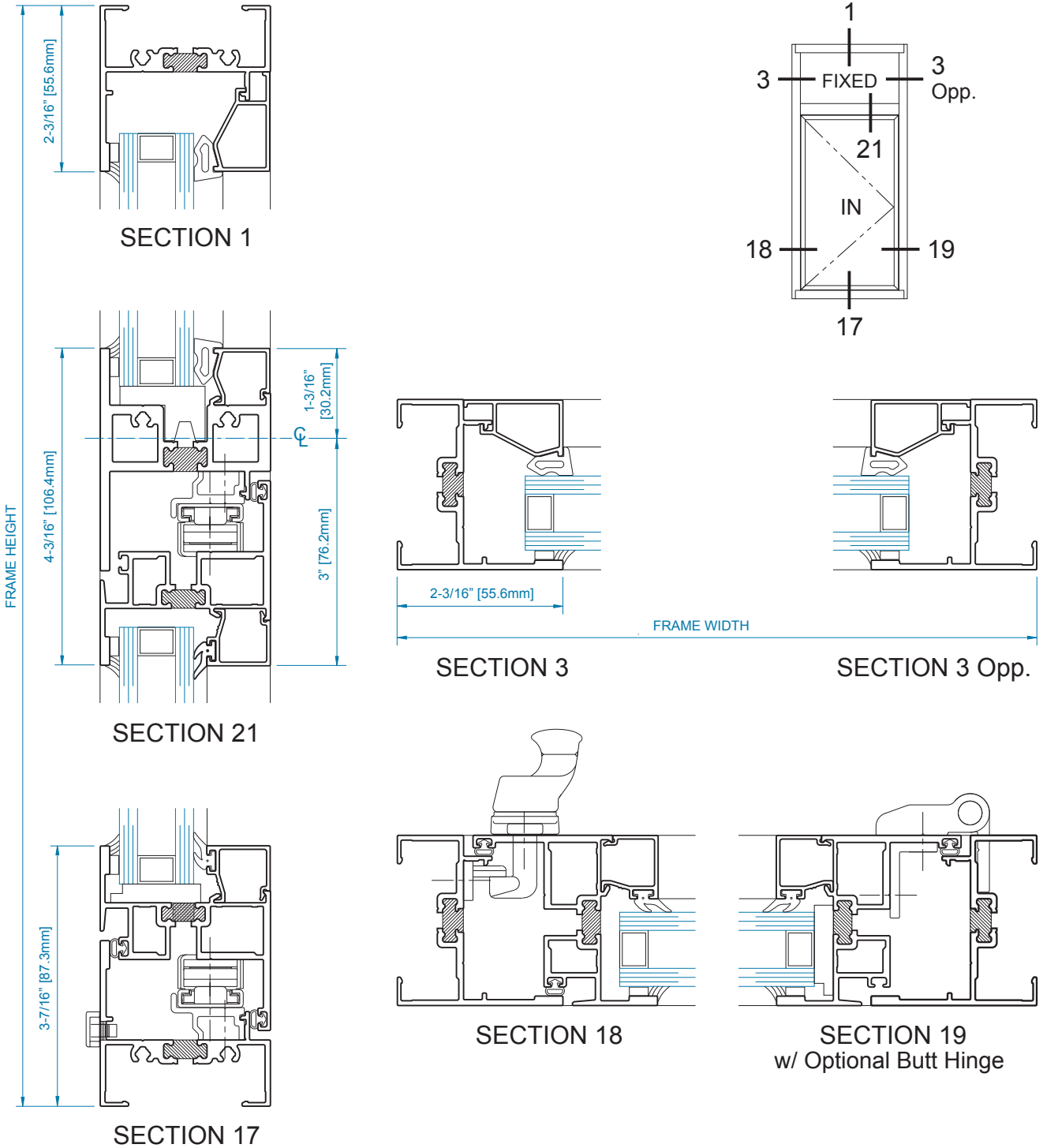

YOW 225 TU FIXED-CASEMENT INSWING 1" Glazing

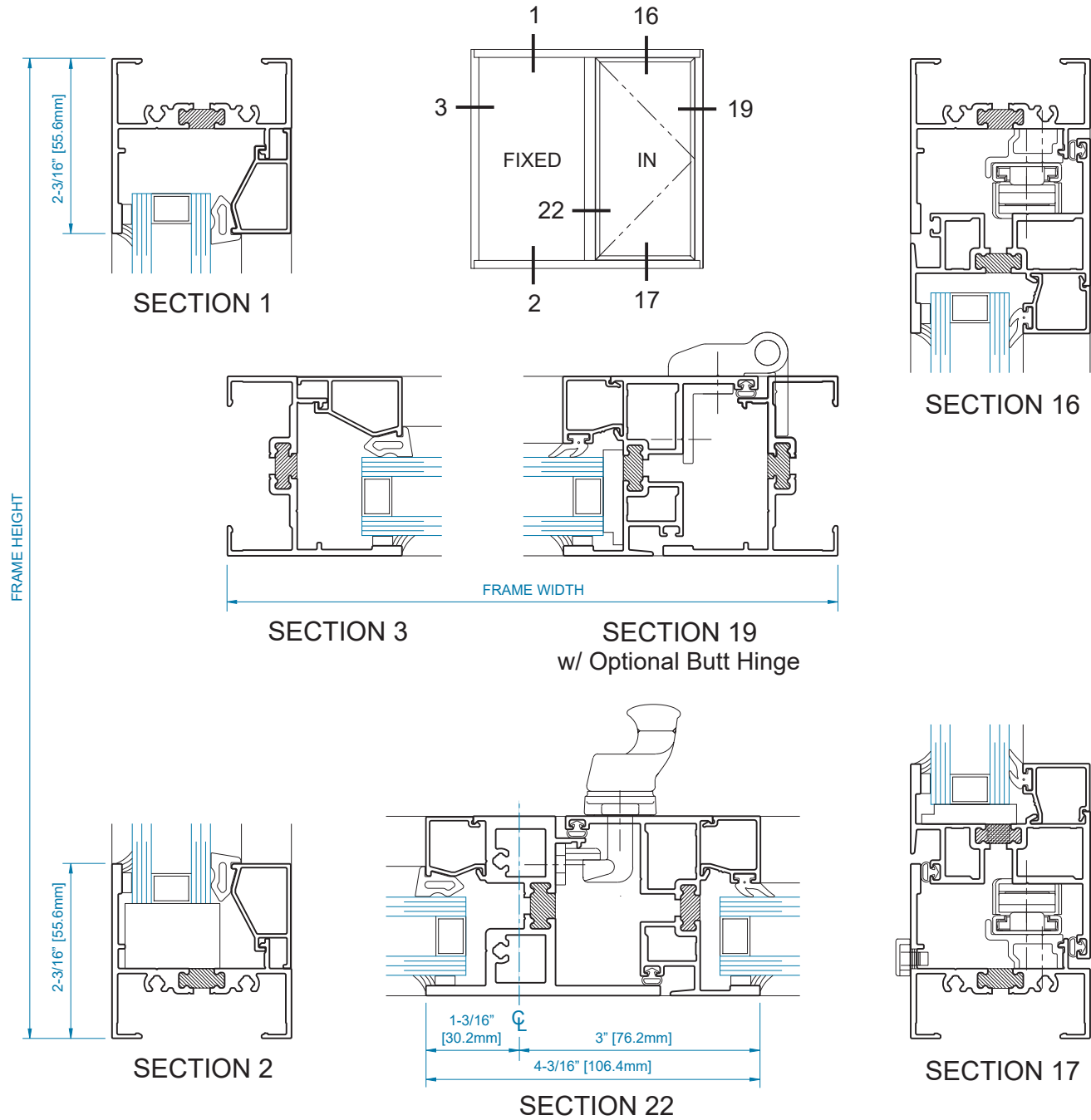

SCALE: 1/2 SIZE



YOW 225 TU CASEMENT INSWING-FIXED-CASEMENT INSWING
1" Glazing

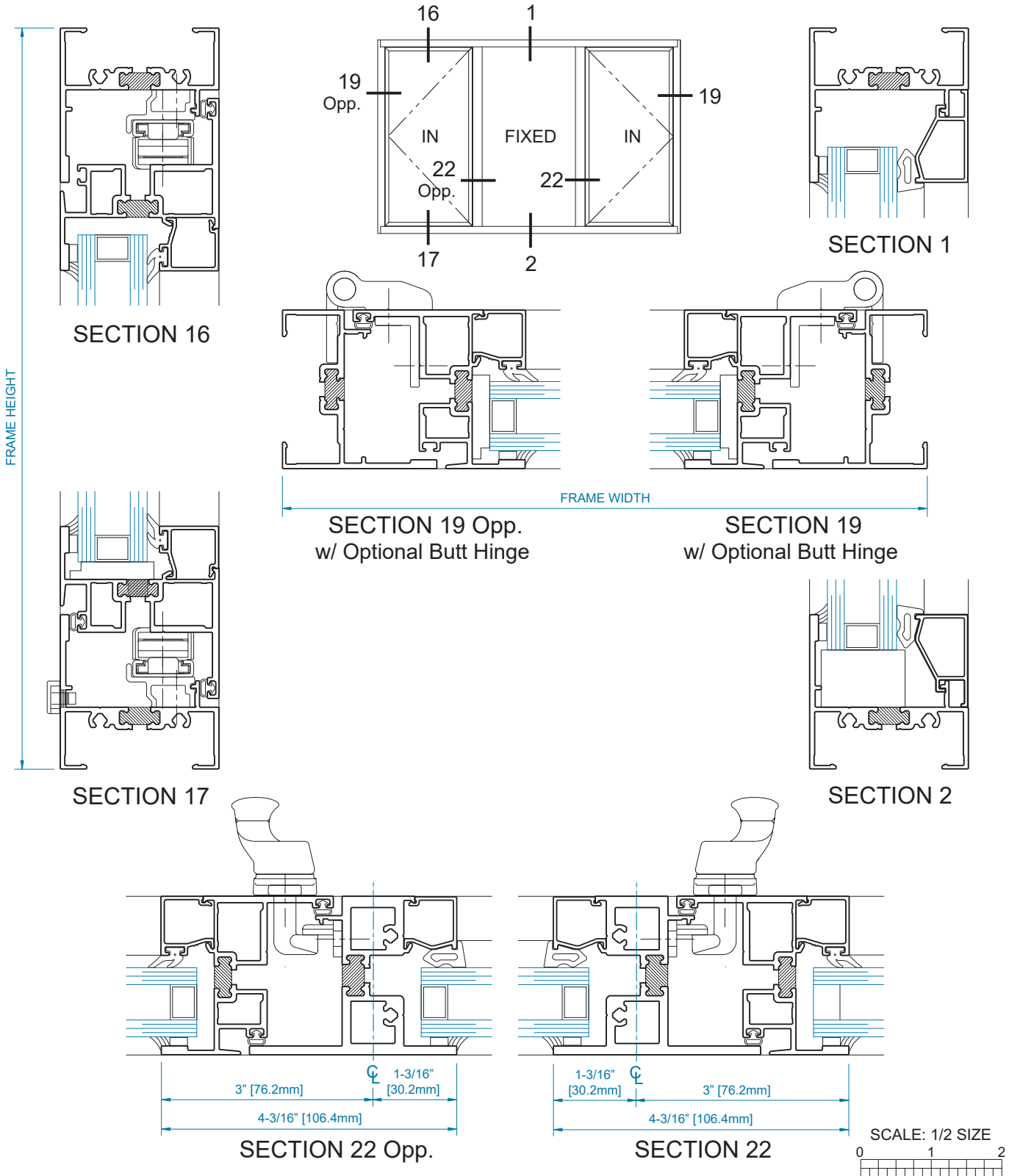

YOW 225 TU PROJECT OUT 1" Glazing

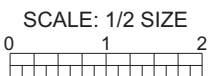
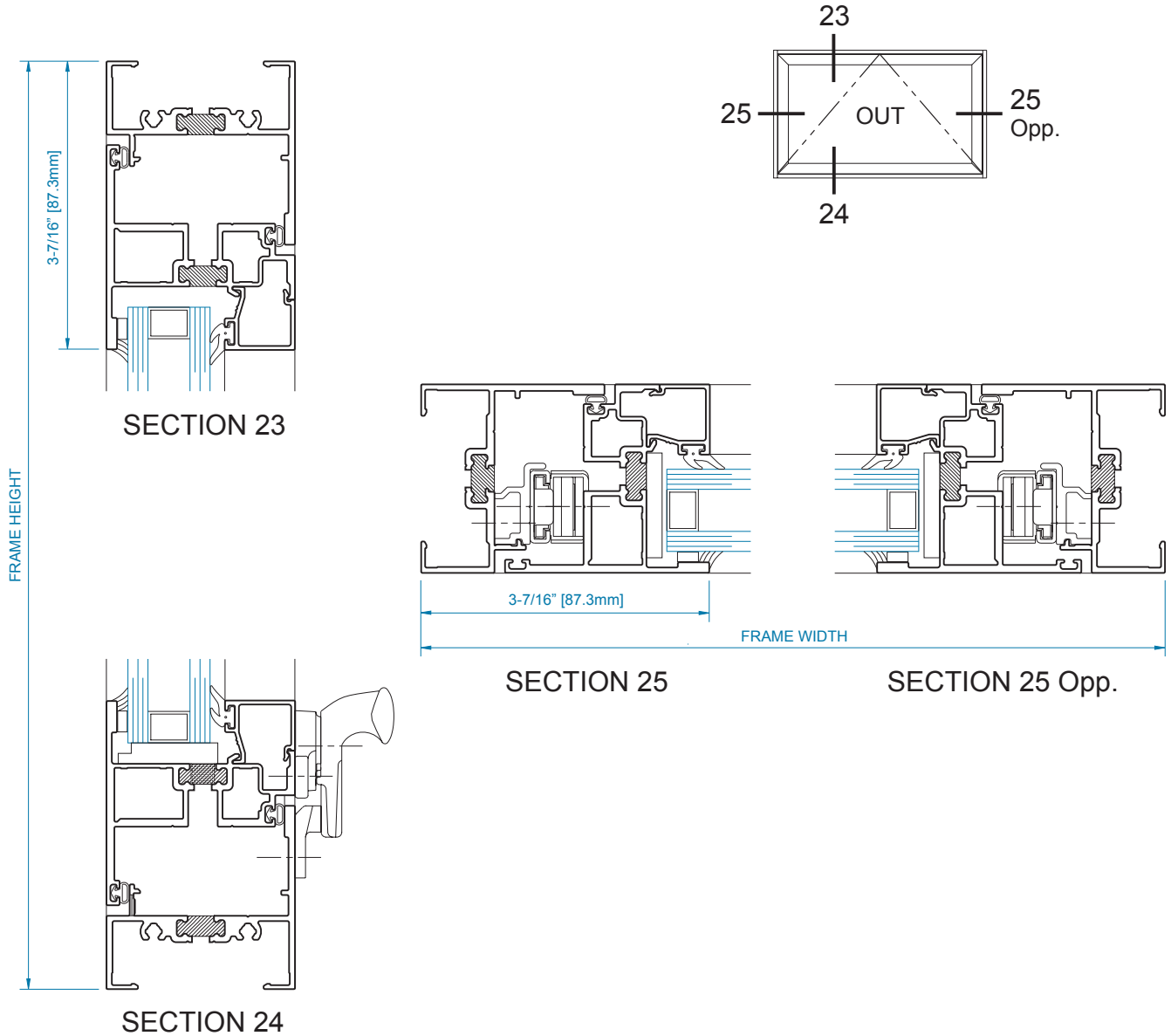

YOW 225 TU FIXED/PROJECT OUT
1" Glazing

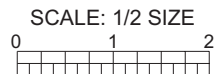
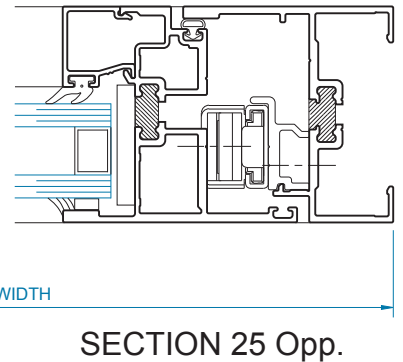
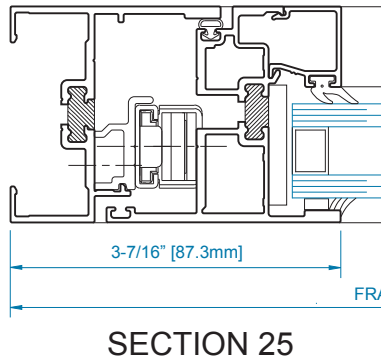
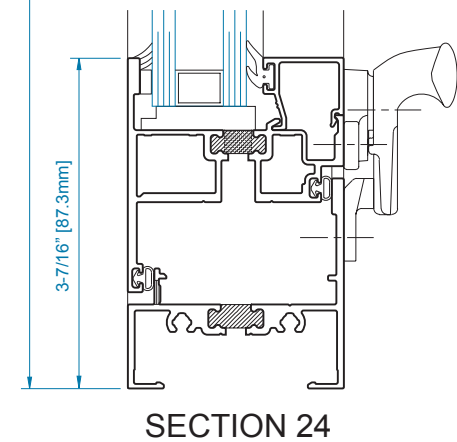
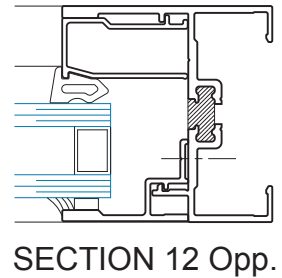
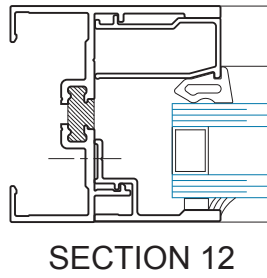
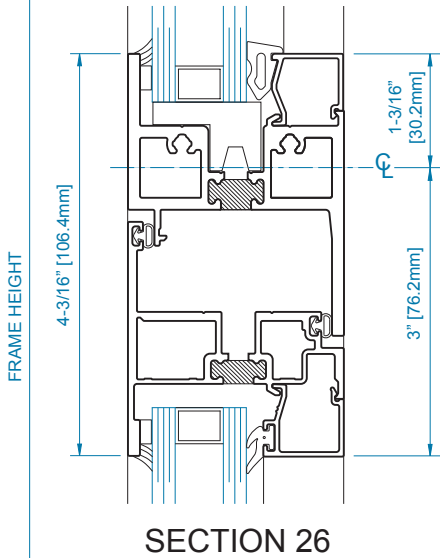
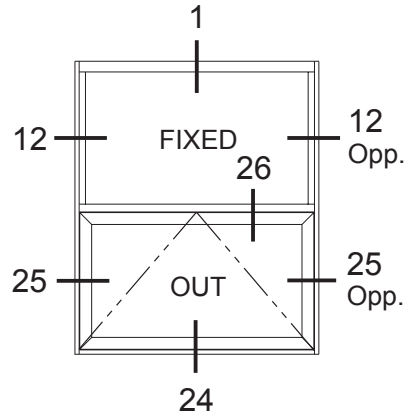
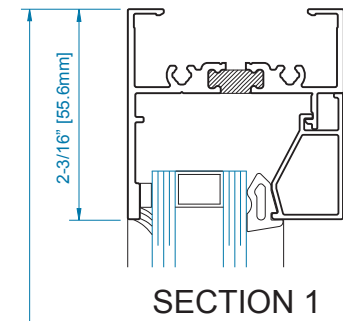

YOW 225 TU DOUBLE FIXED/PROJECT OUT 1" Glazing

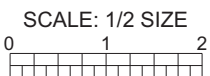
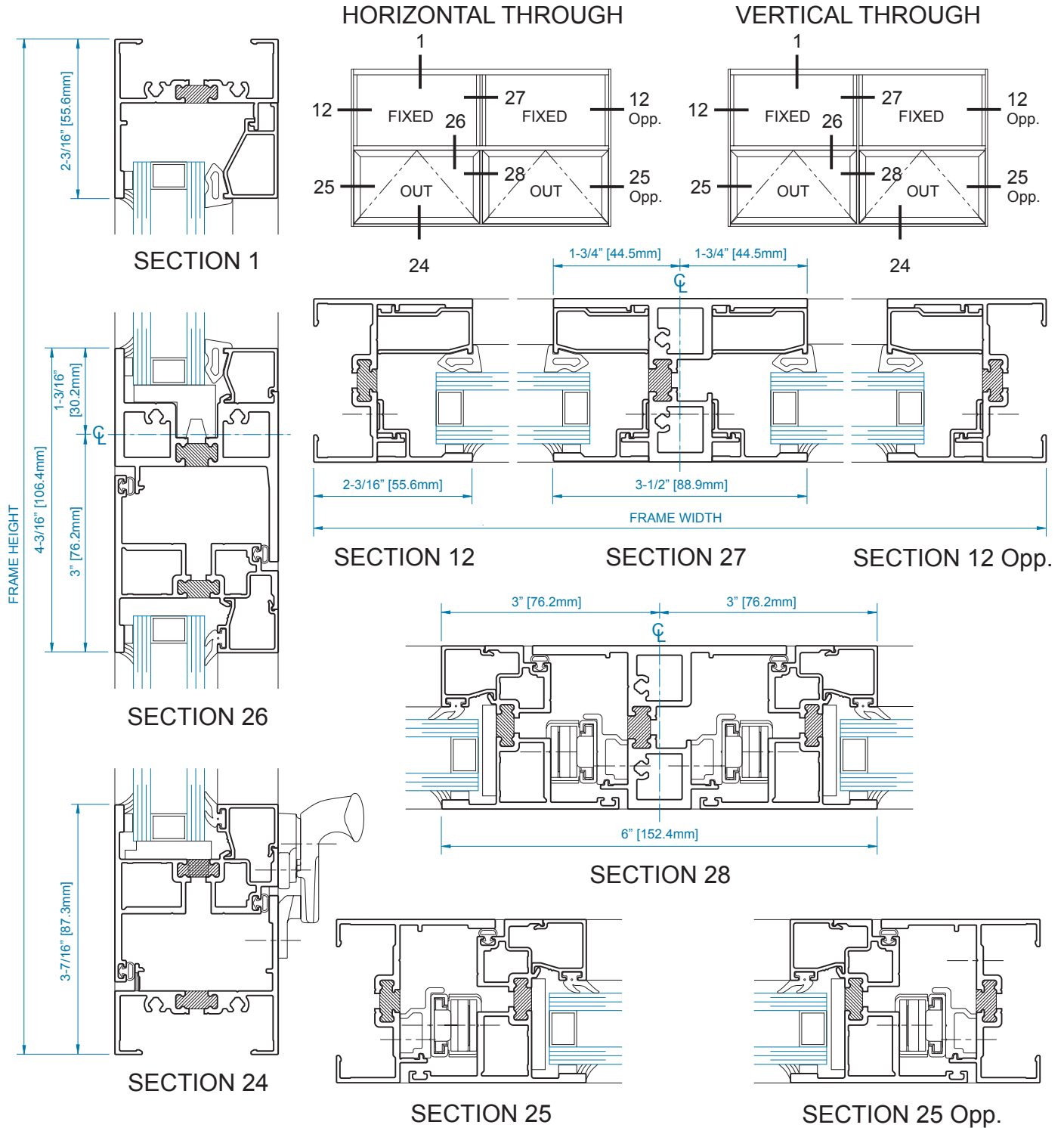

YOW 225 TU PROJECT IN
1" Glazing

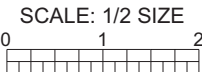
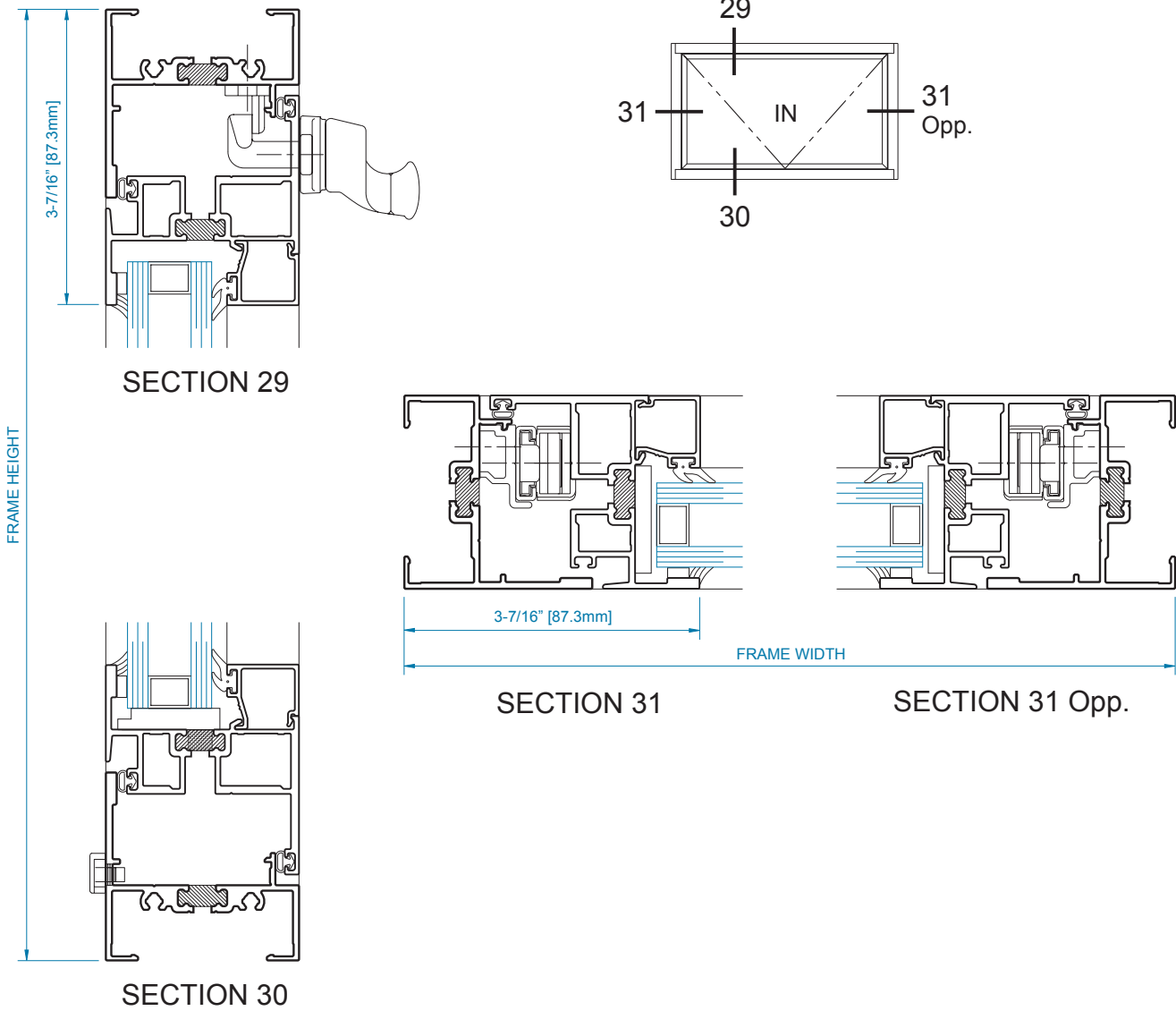

YOW 225 TU FIXED/PROJECT IN 1" Glazing

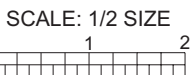
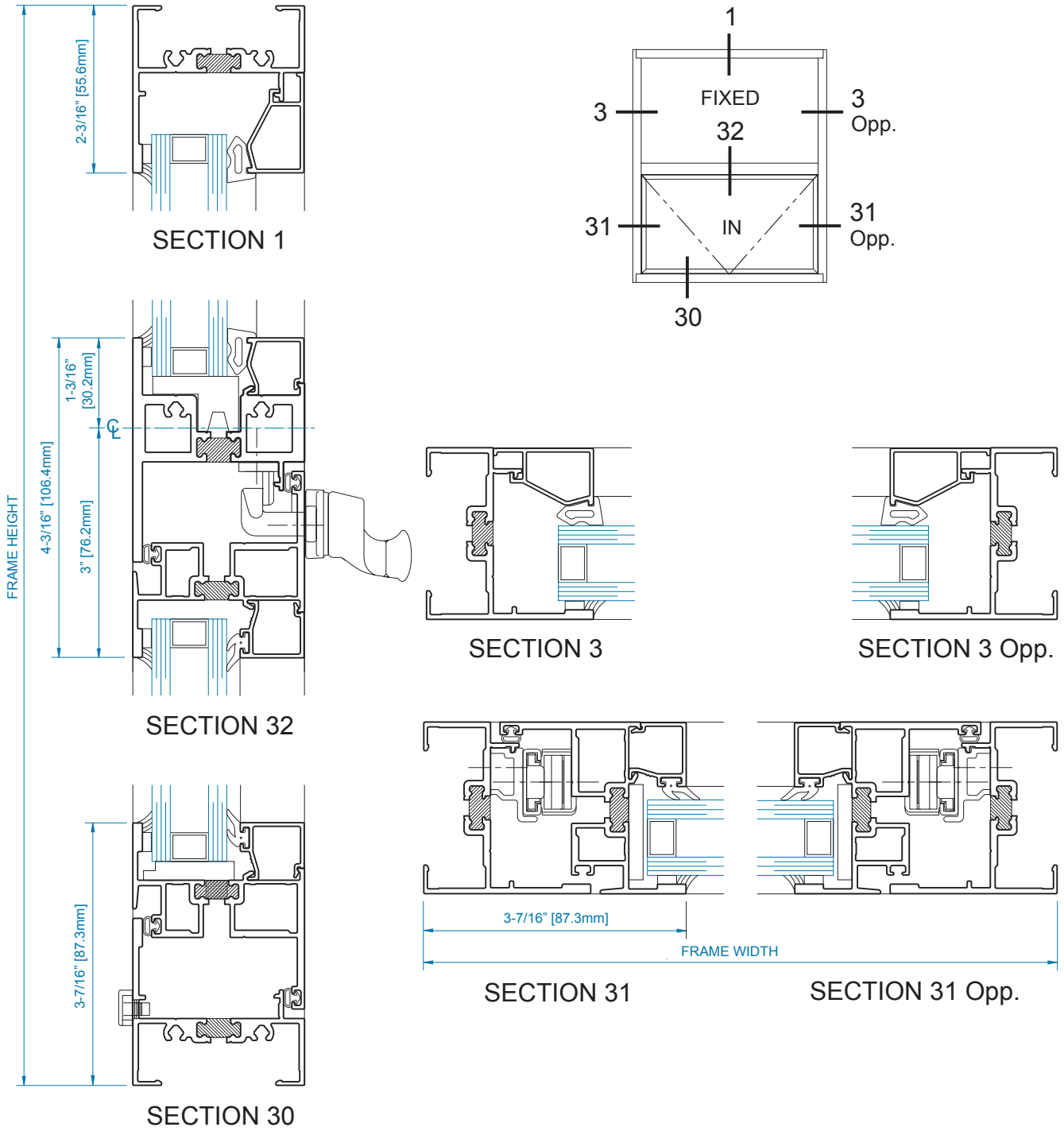

**YOW 225 TU DOUBLE FIXED/PROJECT IN
1" Glazing**

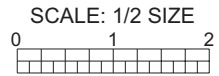
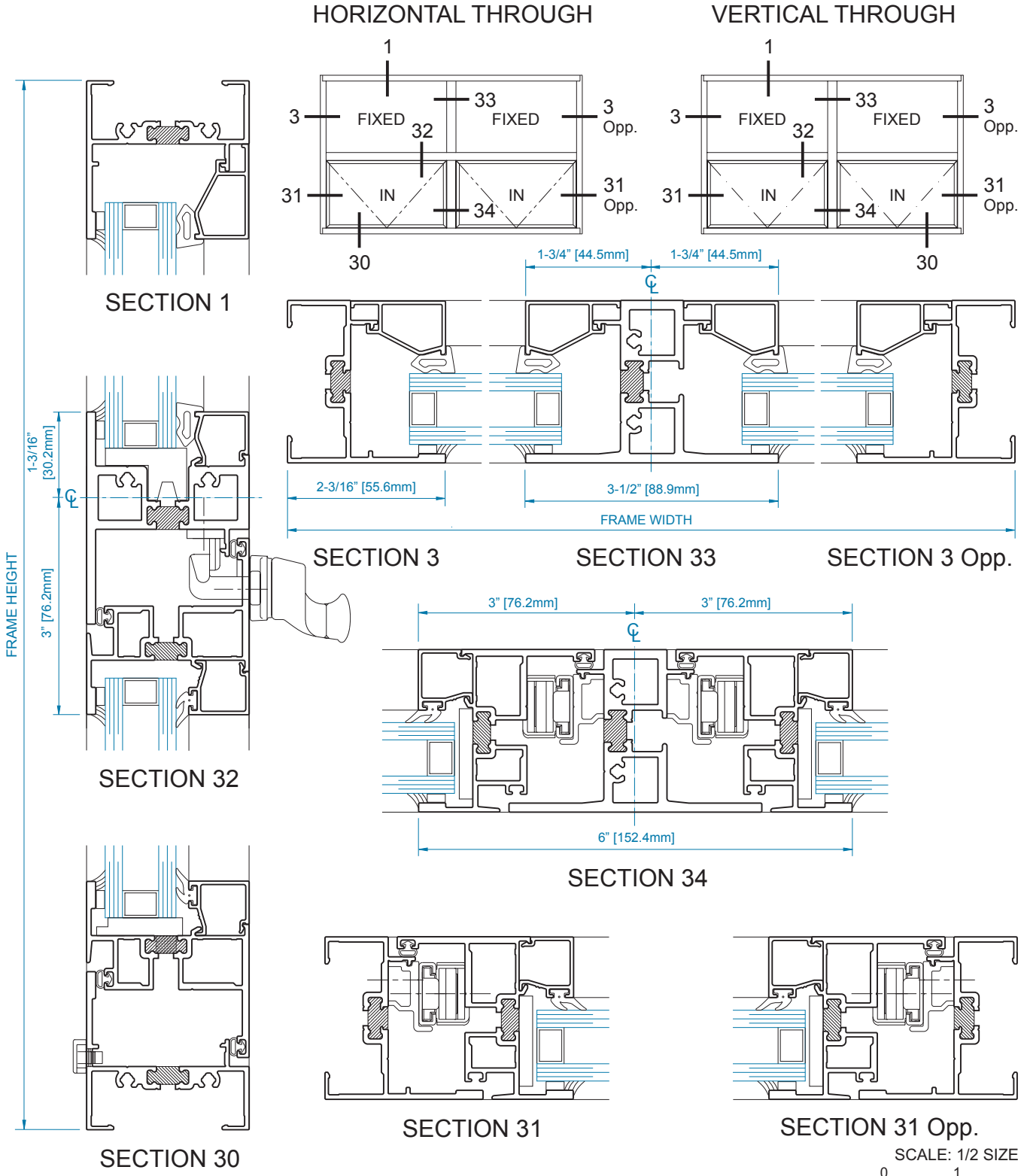

YOW 225 TU FIXED/PROJECT OUT/PROJECT IN 1" Glazing

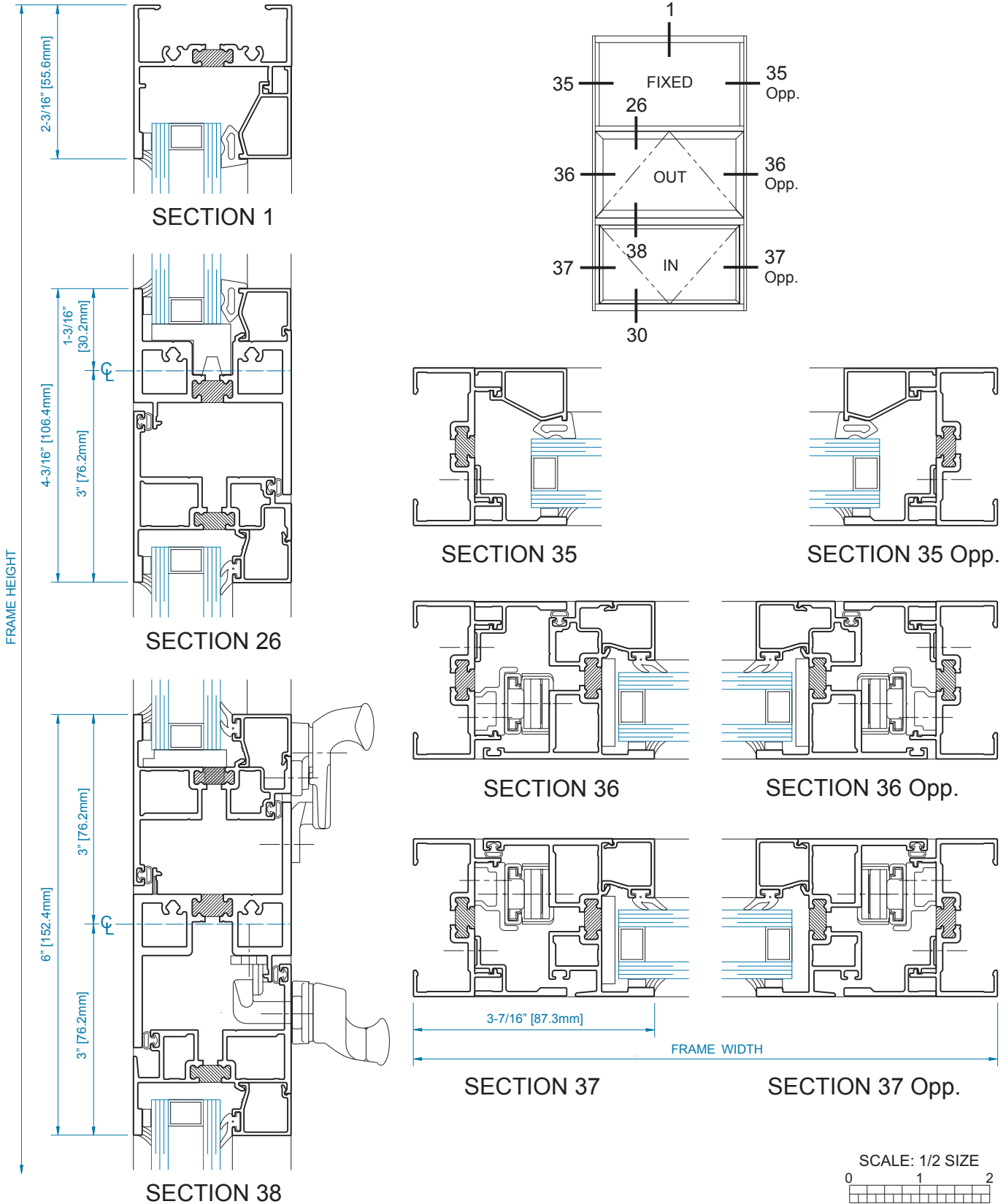

**ACCESSIBLE WINDOW HARDWARE OPTIONS FOR
CASEMENT OUTSWING (4-BAR HINGES)**

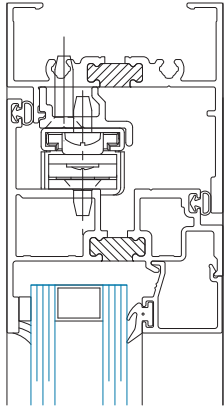

SECTION 1

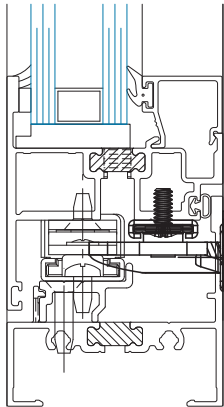
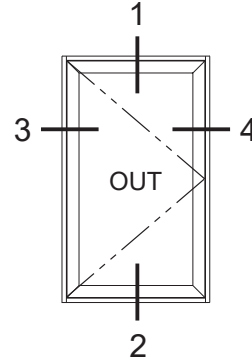

SECTION 2
w/ 4-Bar Hinge

E1-1983 Large
Handle Crank

E1-1713

K-10639

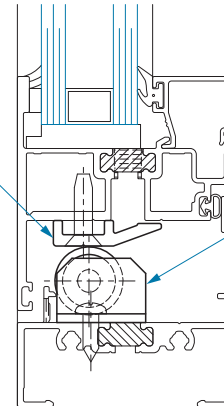

SECTION 2A
At Roller Guide

E1-1983 Large
Handle Crank

E1-1987, E1-1988,
E1-1989 or E1-1990
Single Arm Operator

E1-1966 Standard
4" Multilock Handle,
E1-1994 Optional
8" Multilock Handle

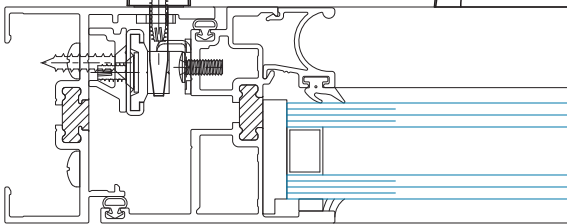
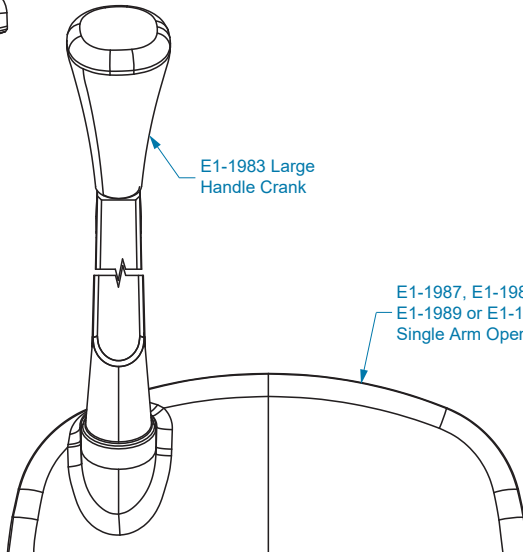
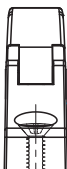

SECTION 3
w/ 4-Bar Hinge

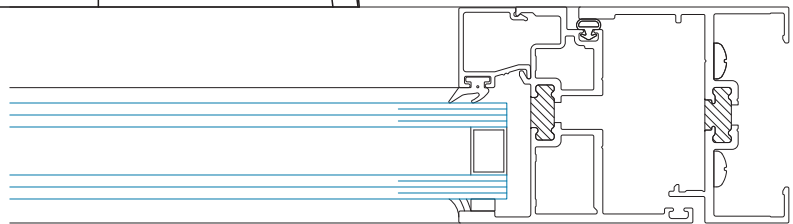

SECTION 4
w/ 4-Bar Hinge

**ACCESSIBLE WINDOW HARDWARE OPTIONS FOR
CASEMENT OUTSWING (BUTT HINGES)**

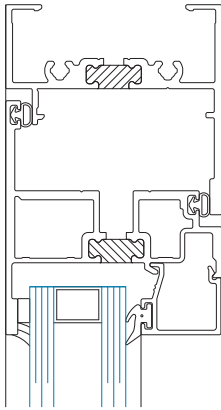

SECTION 1
Head

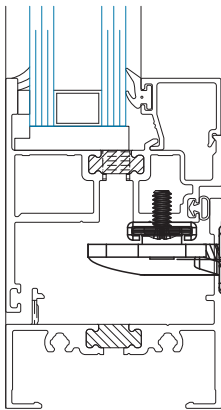
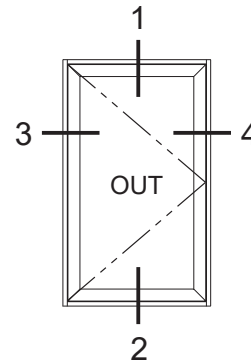

SECTION 2
Sill

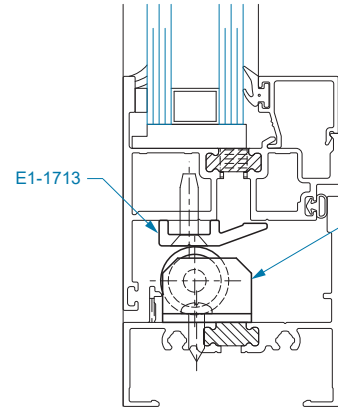
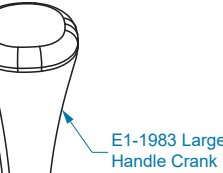
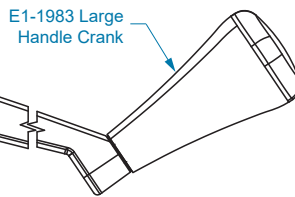

SECTION 2A
At Roller Guide

E1-1987, E1-1988,
E1-1989, or E1-1990
Single Arm Operator

E1-1966 Standard
4" Multilock Handle,
E1-1994 Optional
8" Multilock Handle

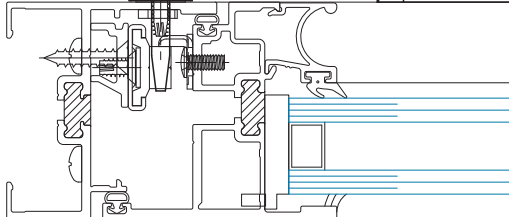
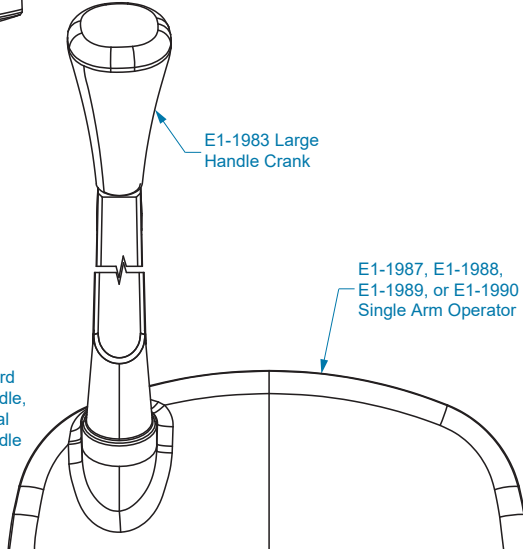
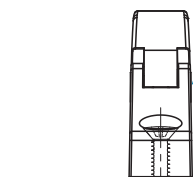

SECTION 3
Lock Jamb

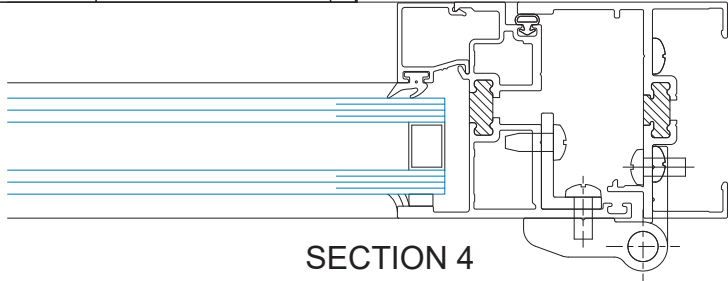

SECTION 4
w/ Butt Hinge

**ACCESSIBLE WINDOW HARDWARE OPTIONS FOR
CASEMENT INSWING**

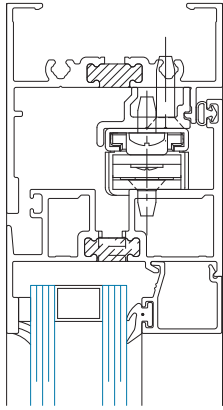

SECTION 1
Head w/
4-Bar Hinge

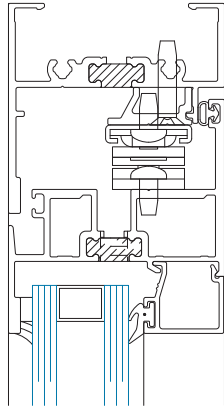

SECTION 1A
Head w/
Butt Hinge

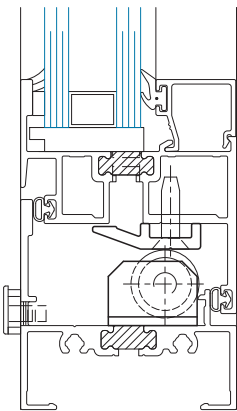
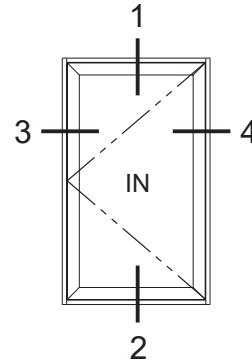

SECTION 2
Sill for 4-Bar
& Butt Hinges

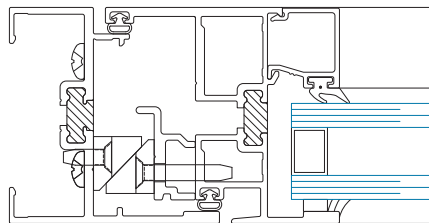

SECTION 3
w/ 4-Bar Hinge

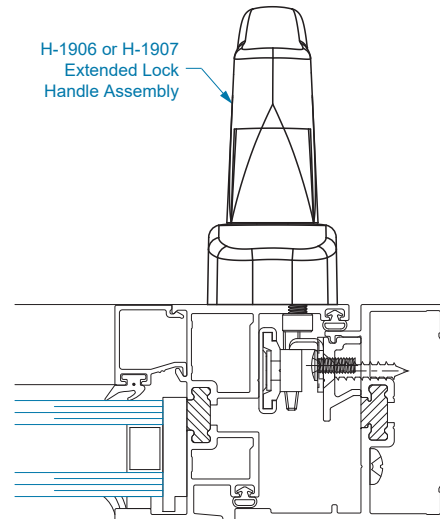

SECTION 4

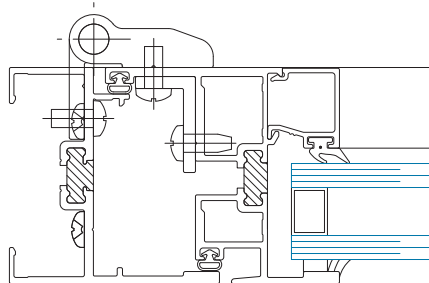

SECTION 3A
w/ Butt Hinge

**ACCESSIBLE WINDOW HARDWARE OPTIONS FOR
PROJECT OUT**

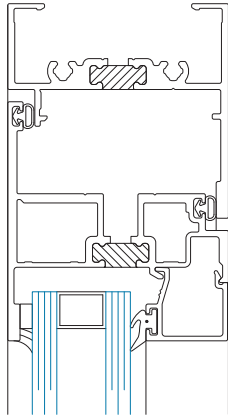
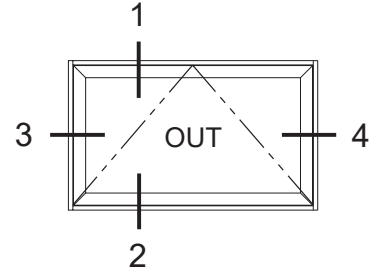

SECTION 1

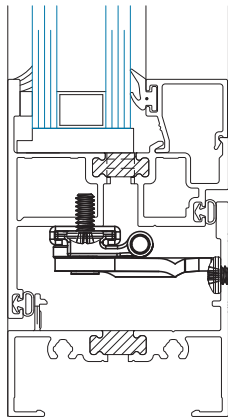

**SECTION 2
w/ 4-Bar Hinge**

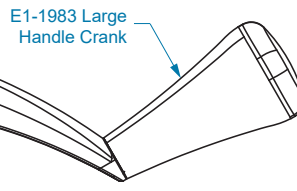

E1-1983 Large
Handle Crank

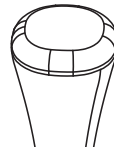

E1-1983 Large
Handle Crank

E1-1992
Dual Arm Operator

E1-1966 Standard
4" Multilock Handle,
E1-1994 Optional
8" Multilock Handle

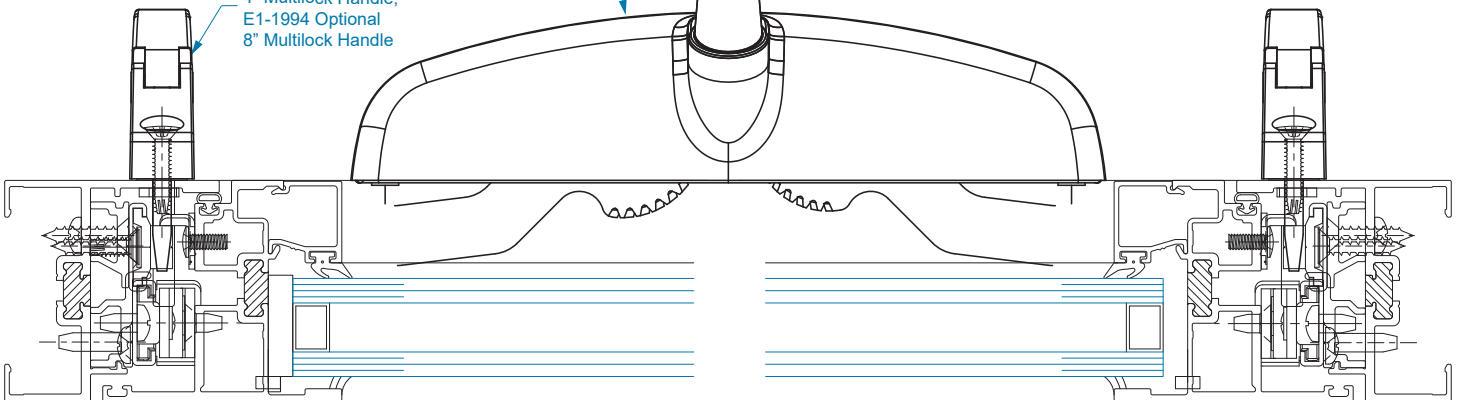

**SECTION 3
w/ 4-Bar Hinge**

**SECTION 4
w/ 4-Bar Hinge**

ACCESSIBLE WINDOW SCREEN OPTIONS FOR CASEMENT OUTSWING

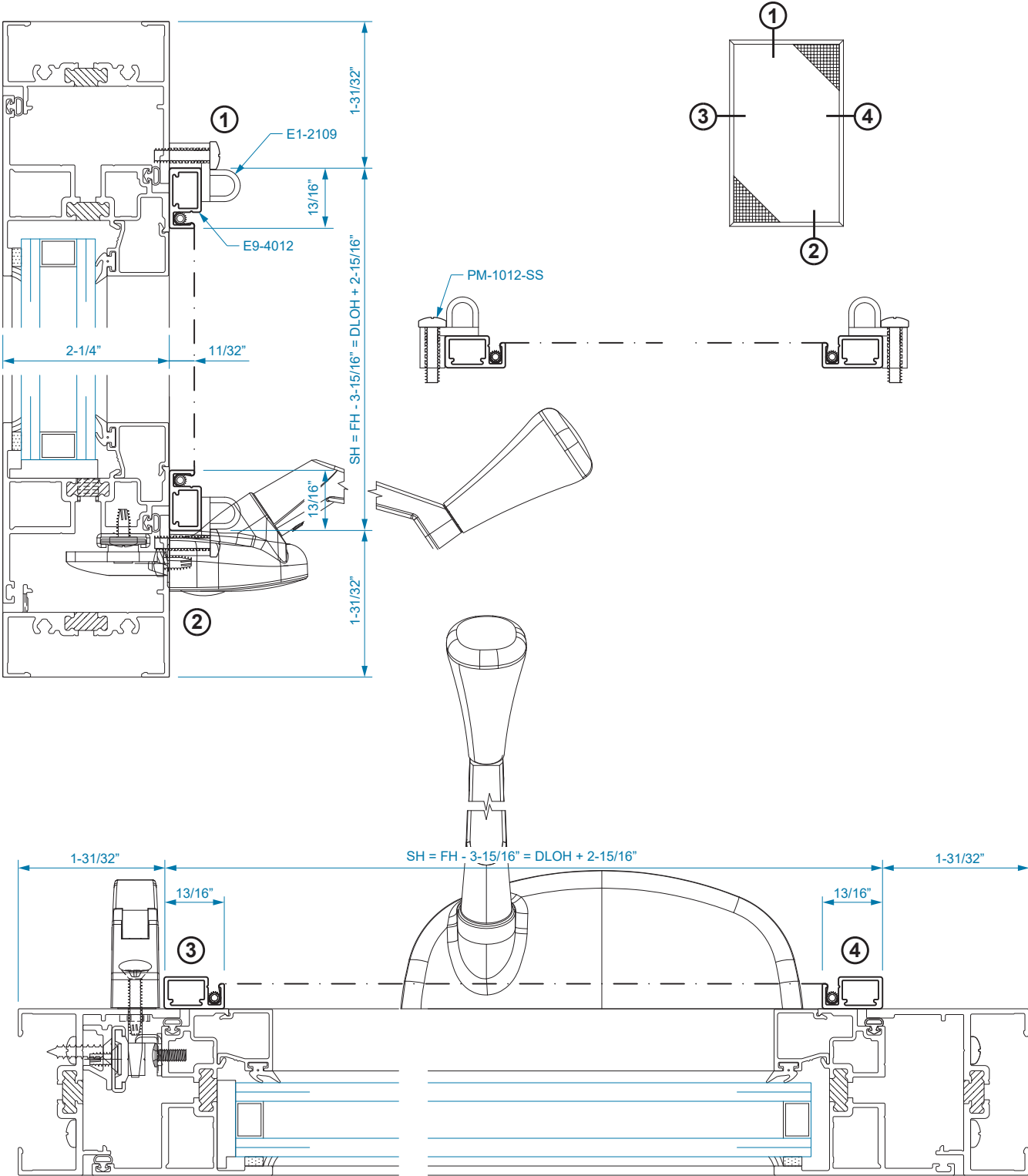

**ACCESSIBLE WINDOW SCREEN OPTIONS FOR
CASEMENT INSWING**

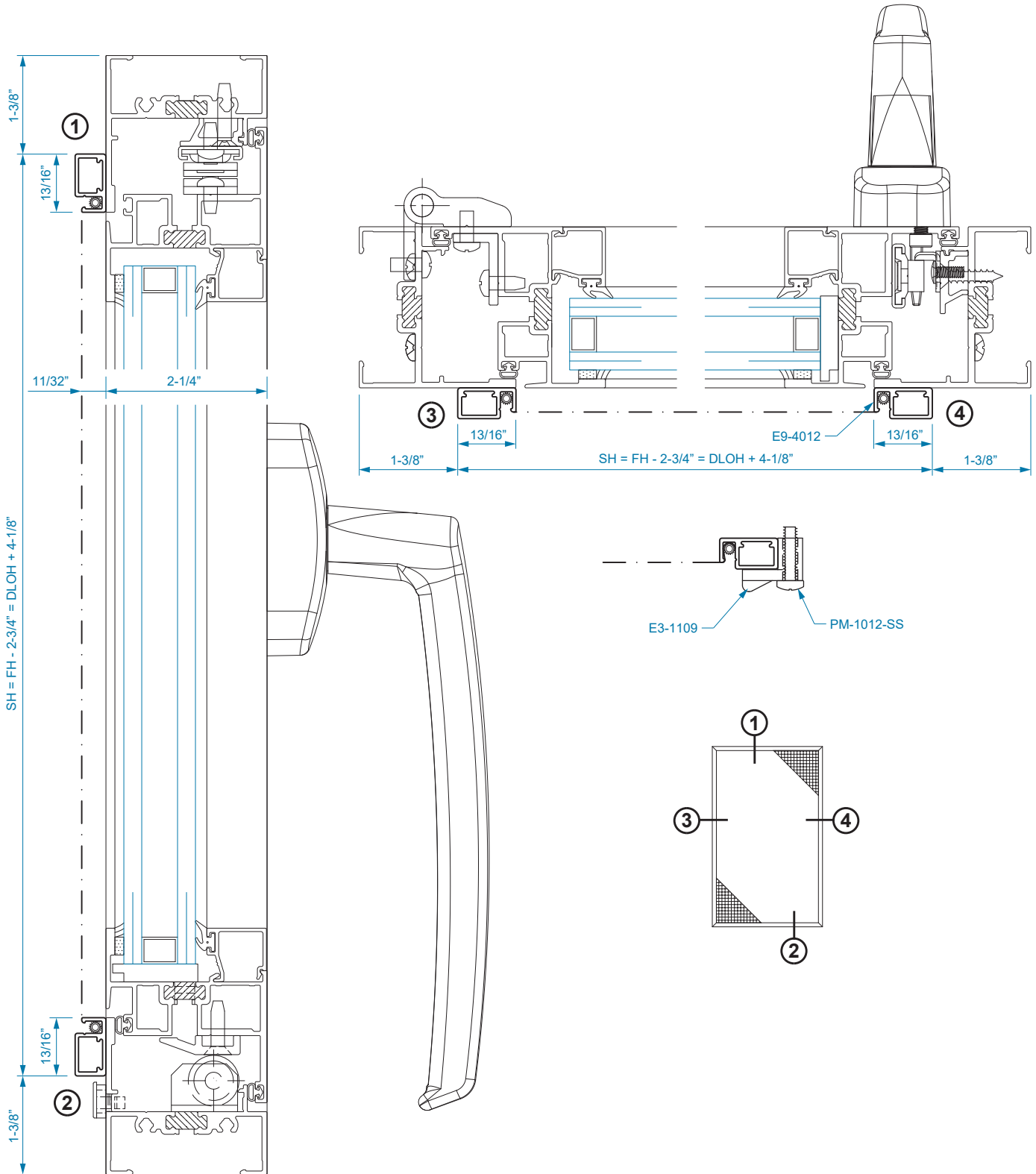

ACCESSIBLE WINDOW SCREEN OPTIONS FOR PROJECT OUT

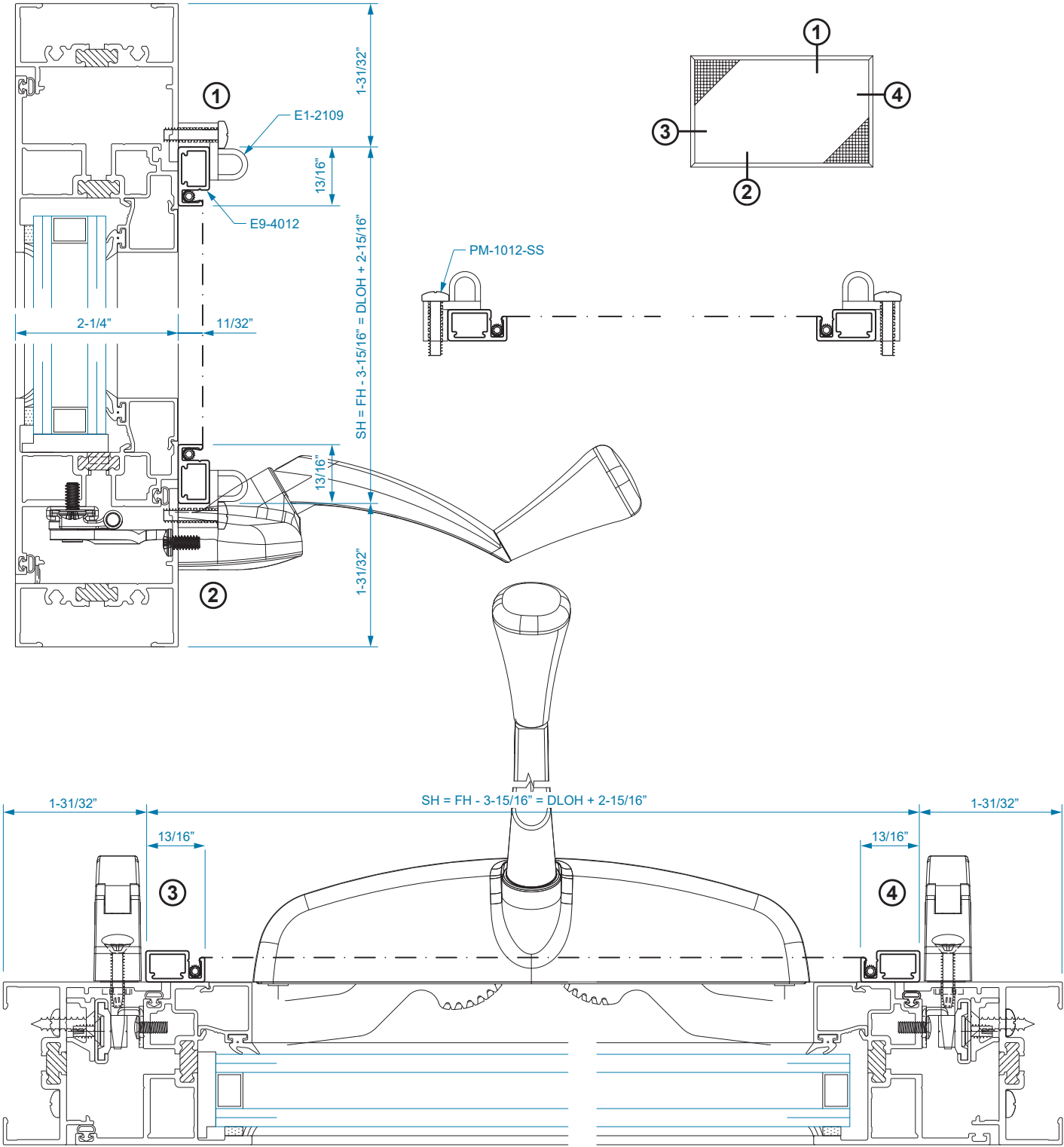

ANCHORING OPTIONS

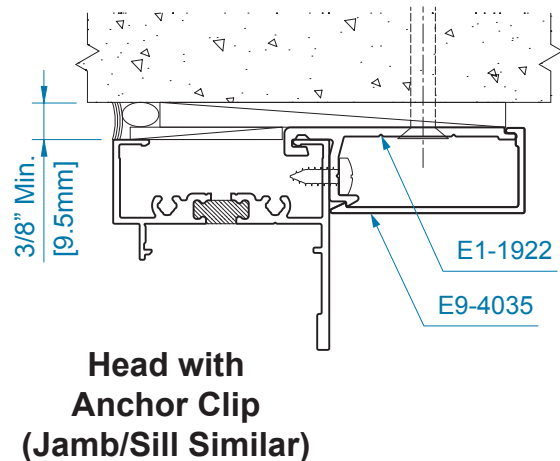
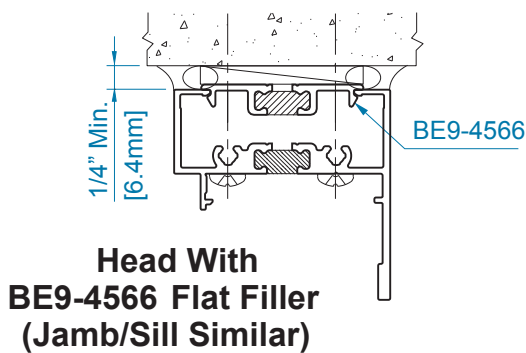
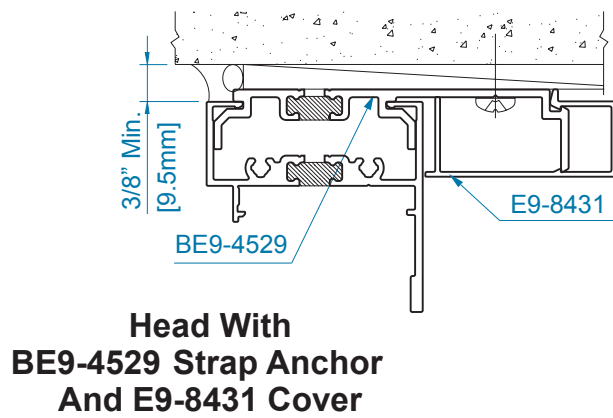
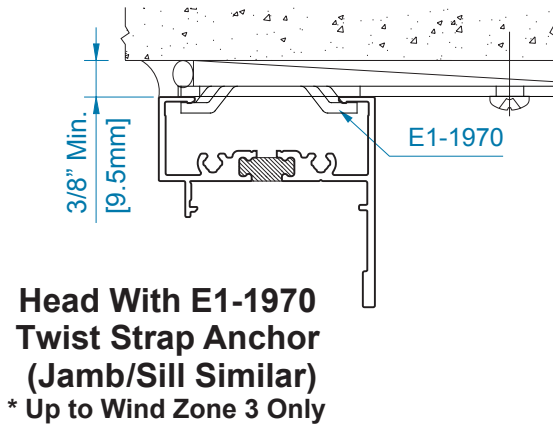
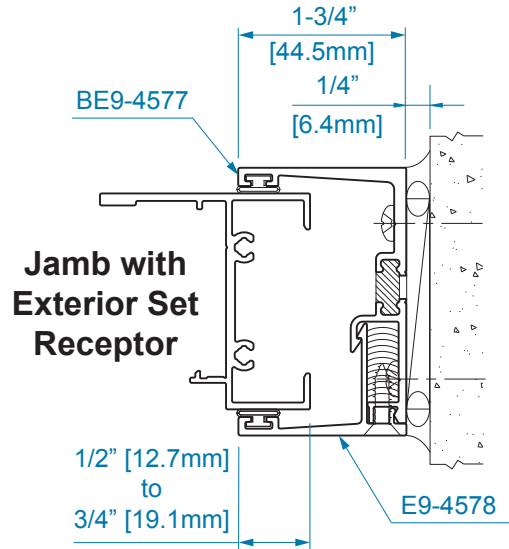
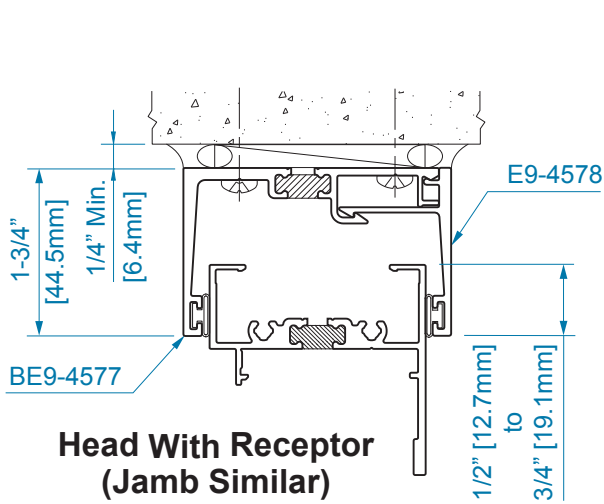

NOTE: Receptors can only be used if end load reaction is less than 450 lbs.
For more information, contact YKK AP.

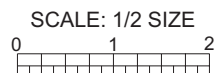

ANCHORING OPTIONS

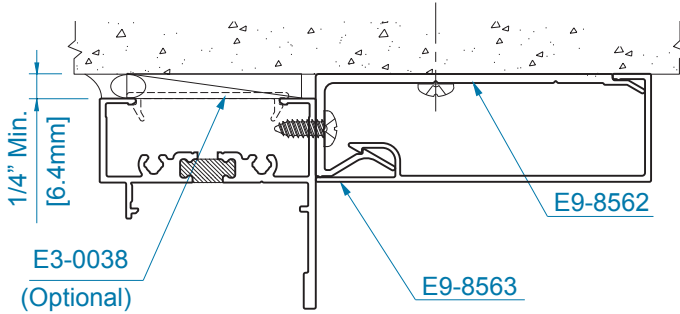

**Head With
1-1/8" x 3-1/2" Trim & Clip
(Jamb/Sill Similar)**

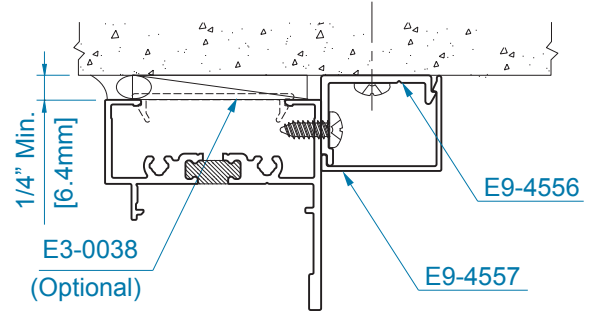

**Head With
1" x 1-1/4" Trim & Clip
(Jamb/Sill Similar)**

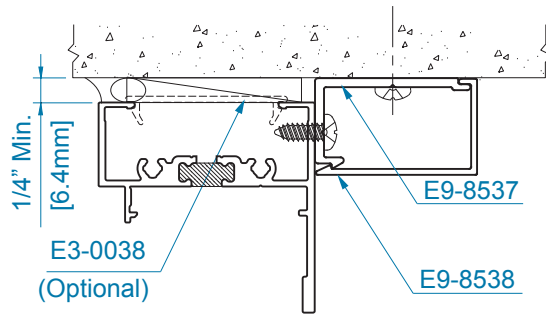

**Head With
1" x 1-11/16" Trim & Clip
(Jamb/Sill Similar)**

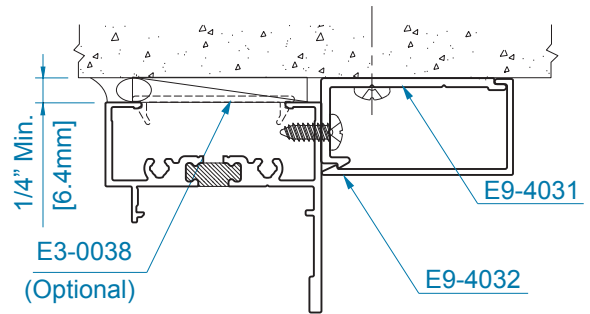

**Head With
1" x 2" Trim & Clip
(Jamb/Sill Similar)**

Refer to installation drawings on Florida Product Approvals.

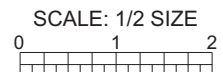

SILL FLASHING & EXTERIOR SILL TRIM DETAILS

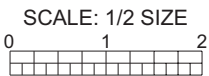
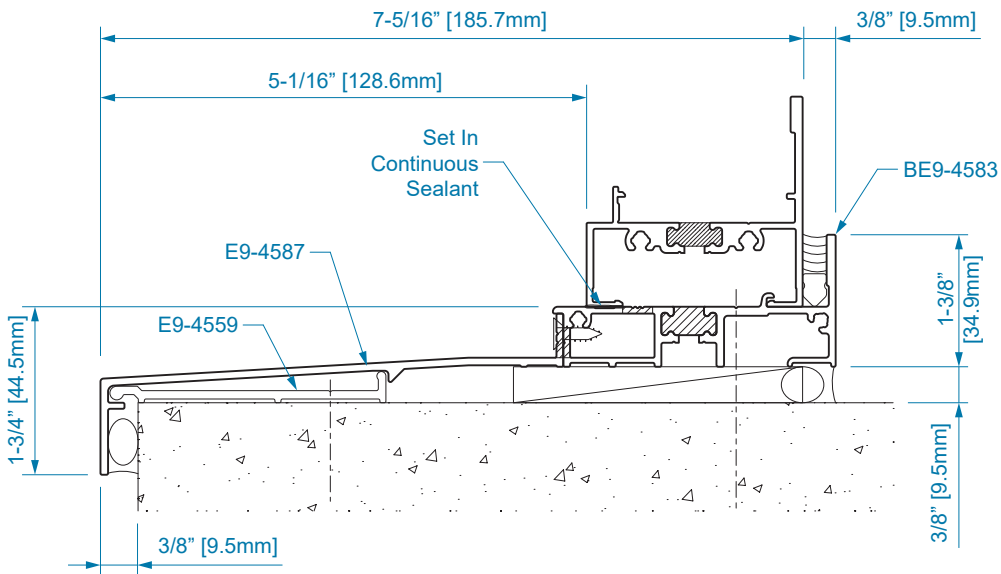
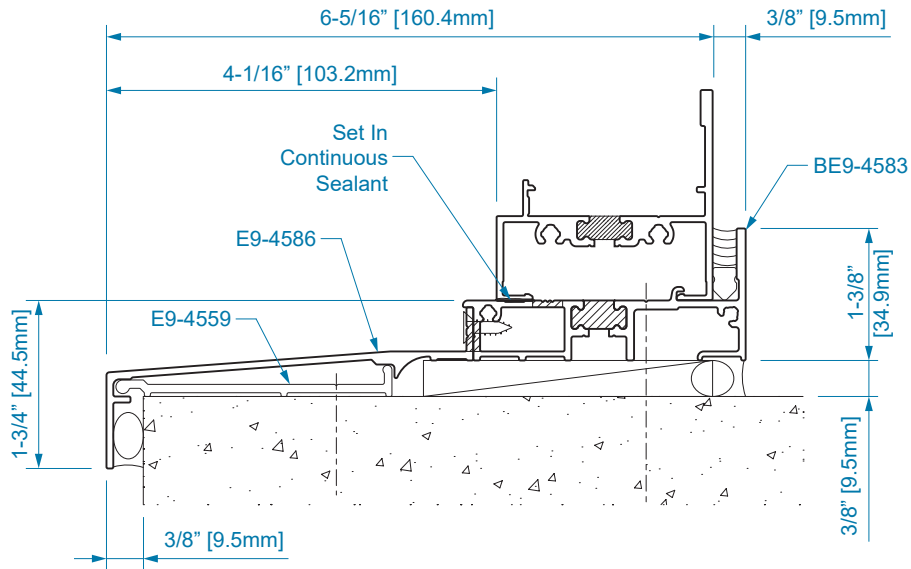

SILL FLASHING & EXTERIOR SILL TRIM DETAILS

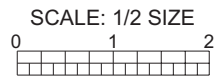
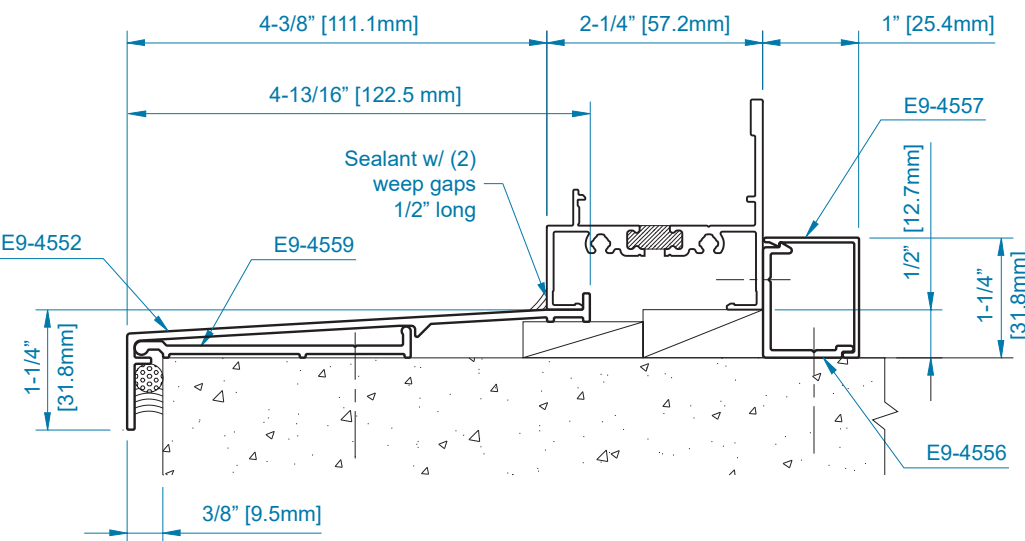
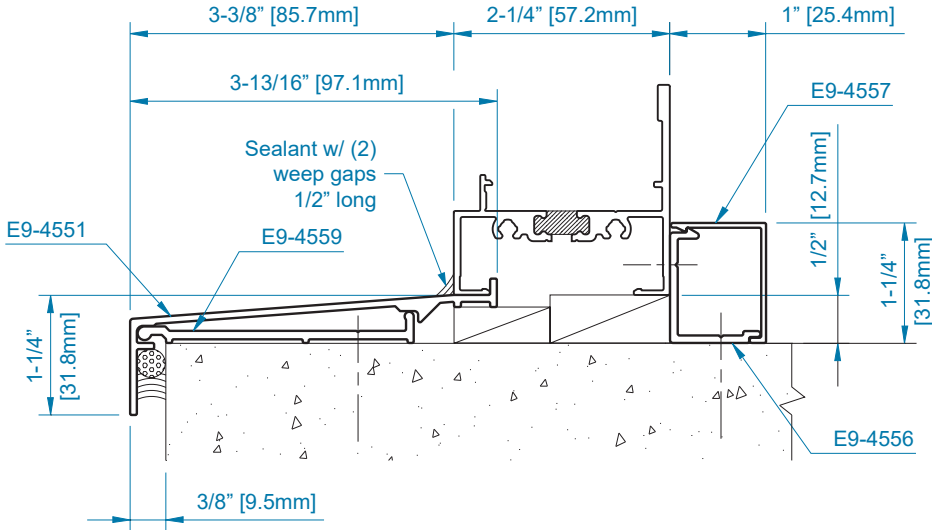

STACKING MULLION OPTIONS (PROJECT OUT, 4-BAR HINGE)

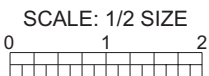
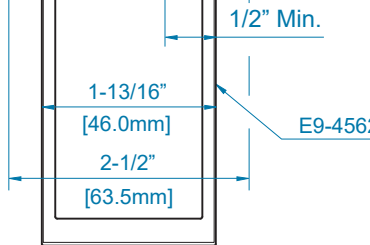
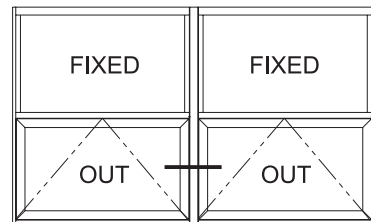
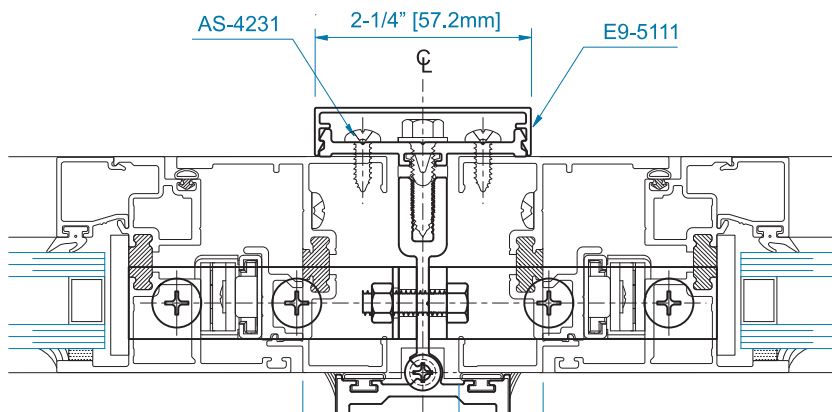
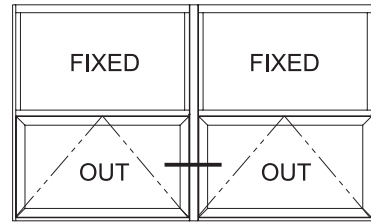
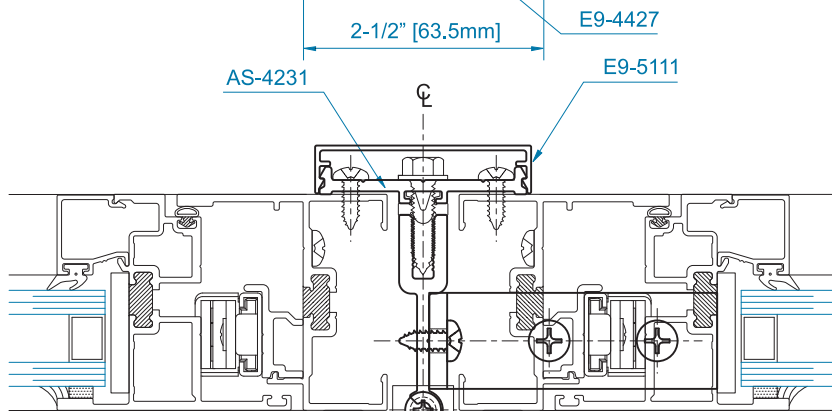
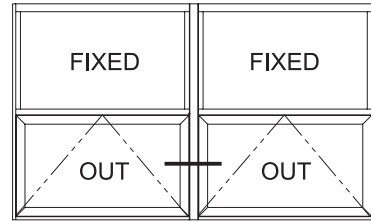
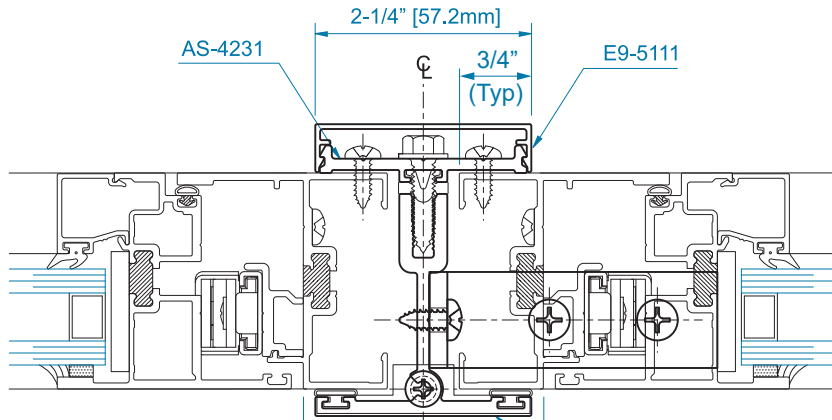

STACKING MULLION OPTIONS (CASEMENT OUTSWING, BUTT HINGE)

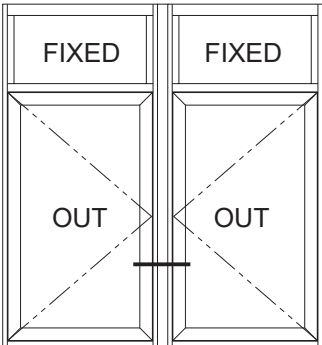
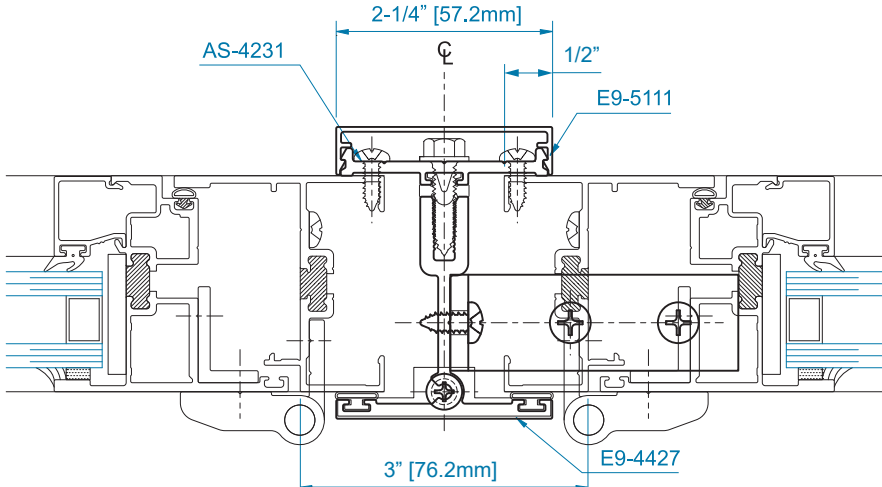

Casement Outswing Shown, Casement Inswing Similar

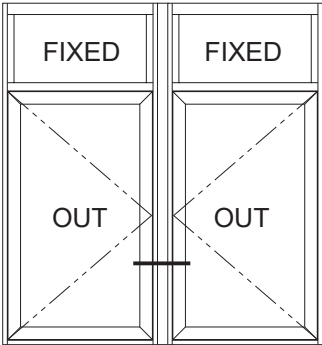
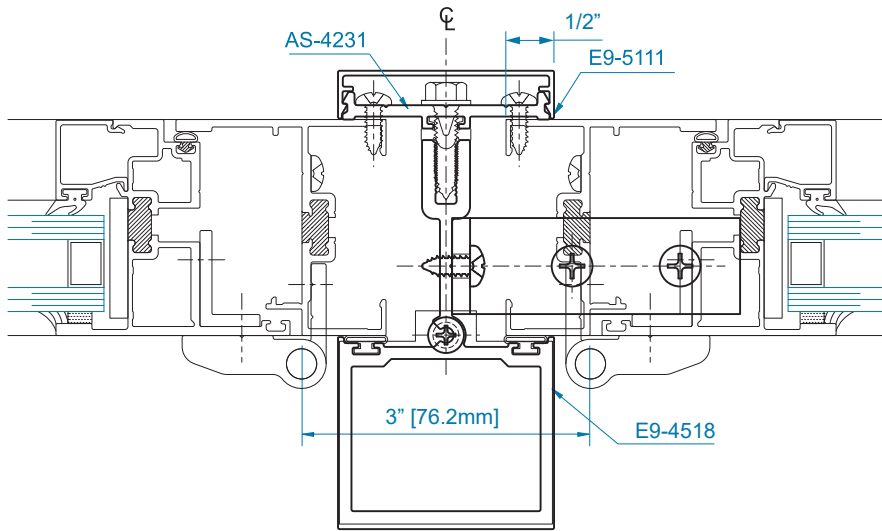

Casement Outswing Shown, Casement Inswing Similar

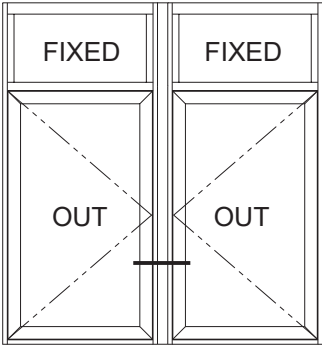
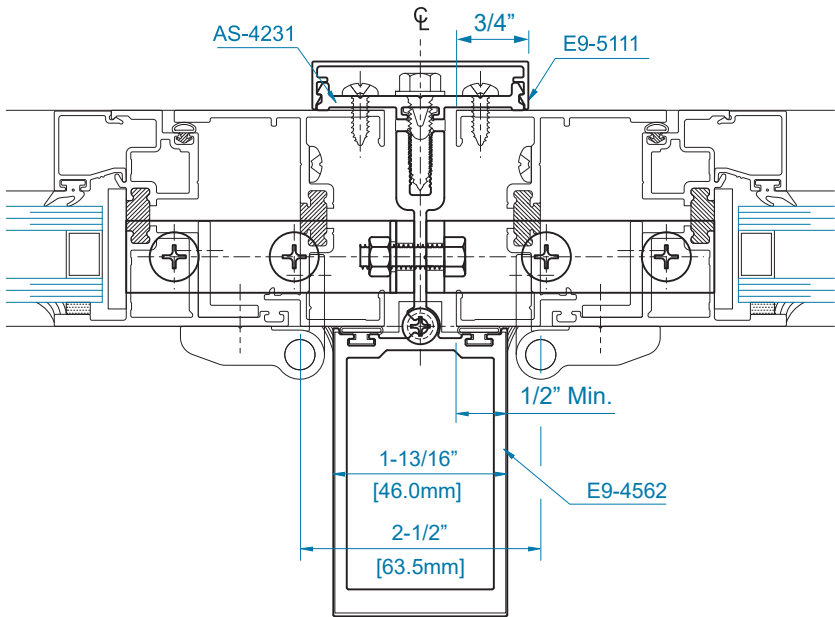

Casement Outswing Only

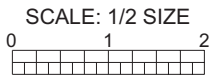

OPTIONAL I-MULLION (WIND ZONE 3 ONLY)

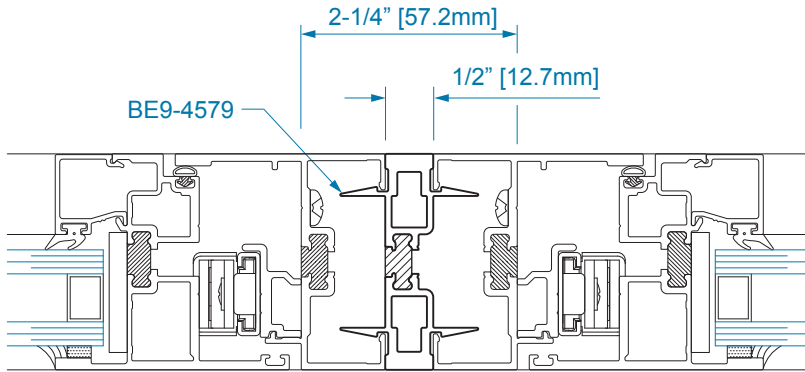

4-BAR HINGES

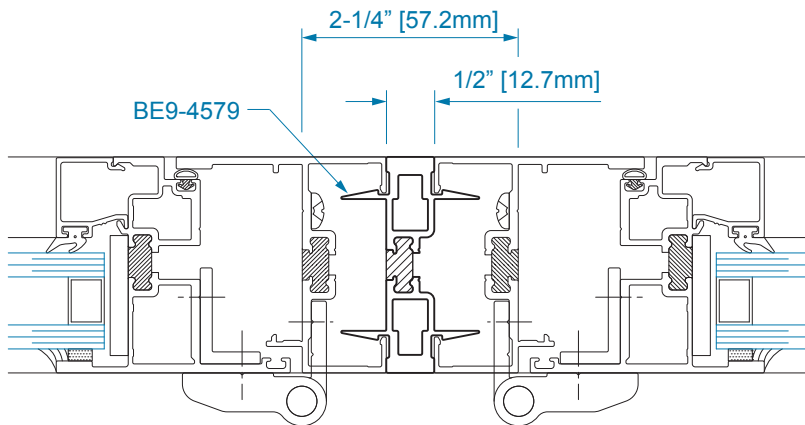
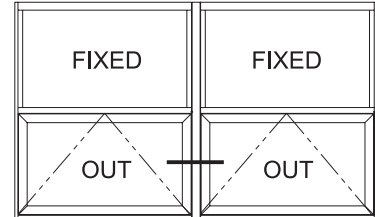

BUTT HINGES

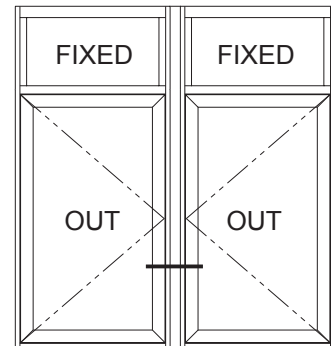

Casement Outswing Shown,
Casement Inswing Similar

MULLION DESIGN PRESSURES

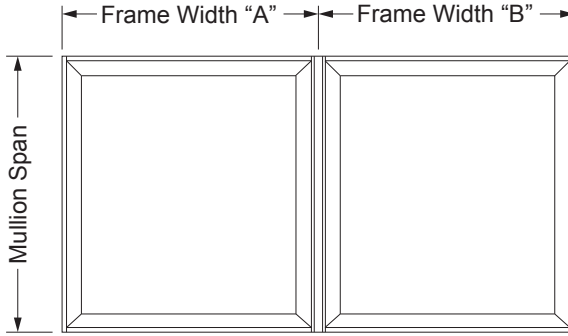

Tributary Width is determined by the following:

$$(\text{Frame Width "A"} + \text{Frame Width "B"}) / 2$$

Refer to Florida Product Approvals for anchoring details and additional information.

Notes:

- 1.) Design pressures are limited either by mullion or anchor screw capacity.
- 2.) Refer to Florida Product Approvals or Engineer of Record for minimum anchor requirements.
- 3.) Design pressures values apply to mullion where two or more windows are listed in a single opening. Lesser design of individual window or mullion of installation shall govern.

E9-4518 Clipped Stacking Mullion Design Pressure Chart									
*1-Maximum Design Pressure Capacity (PSF) +/- (Up to and including Florida's HVHZ - Impact) Used on YOW 225 TU / YOW 225 TUH									
Mull Span [Inches]	Tributary Width [Inches] - Frame								
	12	18	24	36	42	48	56	60	62-3/8
35	150.0	148.9	126.3	113.8	113.8	113.8	113.8	113.8	113.8
48	138.3	99.3	80.7	64.5	61.5	60.5	60.5	60.5	60.5
54	121.0	86.1	69.2	53.8	50.3	48.4	47.8	47.8	47.8
62	103.7	73.1	58.1	44.0	40.5	38.2	36.6	36.3	36.3
66	96.8	67.9	53.8	40.3	36.9	34.6	32.8	32.3	32.1
72	88.0	61.5	48.4	35.9	32.5	30.3	28.3	27.7	27.4
80	78.5	54.5	42.7	31.2	28.1	25.9	23.9	23.2	22.9
84	74.5	51.6	40.3	29.3	26.3	24.2	22.2	21.5	21.2

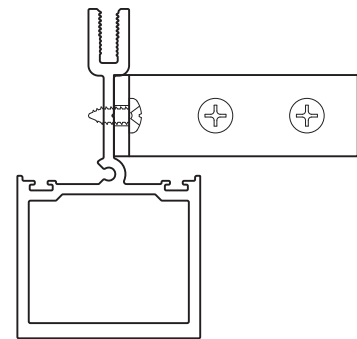

E9-4518 Unclipped Stacking Mullion Design Pressure Chart									
Maximum Design Pressure Capacity (PSF) +/- (Up to and including Florida's HVHZ - Impact) Used on YOW 225 TU / YOW 225 TUH									
Mull Span [Inches]	Tributary Width [Inches] - Frame								
	12	18	24	36	42	48	56	60	62-3/8
35	150.0	150.0	150.0	150.0	150.0	150.0	150.0	150.0	150.0
48	150.0	150.0	150.0	150.0	150.0	150.0	150.0	150.0	150.0
54	150.0	150.0	150.0	150.0	150.0	150.0	150.0	150.0	123.1
62	150.0	150.0	150.0	150.0	141.7	131.2	123.6	122.2	81.3
66	150.0	150.0	150.0	137.2	122.4	112.5	104.5	102.3	67.7
72	150.0	150.0	150.0	113.3	100.4	91.4	83.6	81.1	53.3
80	150.0	150.0	130.1	90.2	79.4	71.7	64.6	62.1	40.6
84	150.0	150.0	117.6	81.3	71.3	64.2	57.6	55.2	36.0

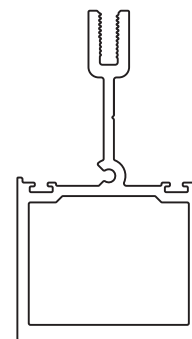

See notes 1, 2, and 3.

MULLION DESIGN PRESSURES

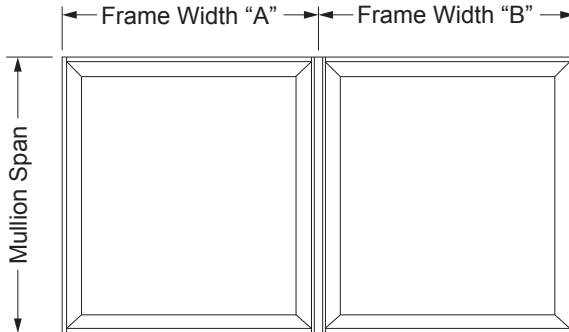

Tributary Width is determined by the following:

$$(\text{Frame Width "A"} + \text{Frame Width "B"}) / 2$$

Refer to Florida Product Approvals for anchoring details and additional information.

Notes:

- 1.) Design pressures are limited either by mullion or anchor screw capacity.
- 2.) Refer to Florida Product Approvals or Engineer of Record for minimum anchor requirements.
- 3.) Design pressures values apply to mullion where two or more windows are listed in a single opening. Lesser design of individual window or mullion of installation shall govern.

E9-4527 Clipped Stacking Mullion Design Pressure Chart								
Maximum Design Pressure Capacity (PSF) +/- (Up to and including Florida's HVHZ - Impact) Used on YOW 225 TU/ YOW 225 TUH								
Mull Span [Inches]	Tributary Width [Inches] - Frame							
	12	18	24	36	42	48	56	60
35	150.0	148.9	126.3	113.8	113.8	113.8	113.8	113.8
48	138.3	99.3	80.7	64.5	61.5	60.5	60.5	60.5
54	121.0	86.1	69.2	53.8	50.3	48.4	47.8	47.8
62	103.7	73.1	58.1	44.0	40.5	38.2	36.6	36.3

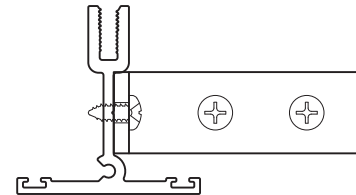

See notes 1, 2, and 3.

E9-4527 Unclipped Stacking Mullion Design Pressure Chart								
Maximum Design Pressure Capacity (PSF) +/- (Up to and including Florida's HVHZ - Impact) Used on YOW 225 TU / YOW 225 TUH								
Mull Span [Inches]	Tributary Width [Inches] - Frame							
	12	18	24	36	42	48	56	60
35	150.0	150.0	150.0	150.0	150.0	150.0	150.0	150.0
48	150.0	150.0	150.0	133.7	125.1	122.3	122.3	122.3
54	150.0	150.0	137.9	100.8	92.2	87.4	85.9	85.9
62	150.0	134.0	102.8	73.4	65.9	61.0	57.5	56.8

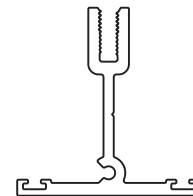

See notes 1, 2, and 3.

MULLION DESIGN PRESSURES

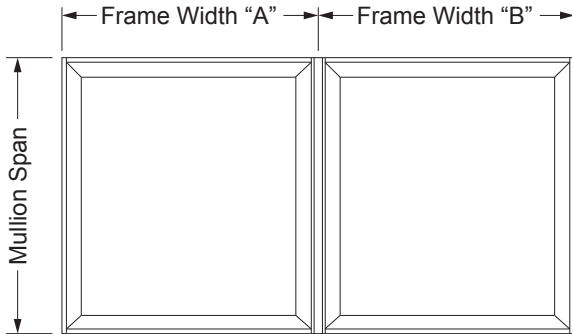

Tributary Width is determined by the following:

$$(\text{Frame Width "A"} + \text{Frame Width "B"}) / 2$$

Refer to Florida Product Approvals for anchoring details and additional information.

E9-4562 Clipped Stacking Mullion Design Pressure Chart								
Maximum Design Pressure Capacity (PSF) +/- (Up to and including Florida's HVHZ - Impact) Used on YOW 225 TU / YOW 225 TUH								
Mull Span [Inches]	Tributary Width [Inches] - Frame							
	12	18	24	36	42	48	56	60
68	150.0	150.0	150.0	150.0	150.0	150.0	150.0	142.3
72	150.0	150.0	150.0	150.0	148.1	143.0	138.5	130.9
76	150.0	150.0	150.0	150.0	137.9	133.0	128.6	121.2
80	150.0	150.0	150.0	140.6	127.4	121.7	116.6	108.1
84	150.0	150.0	143.9	127.4	114.8	109.6	104.9	97.0
88	150.0	150.0	130.6	115.5	104.0	99.2	94.9	87.6
92	150.0	137.9	119.2	105.3	94.7	90.2	86.3	79.6
93-1/8	150.0	134.5	116.2	102.7	92.3	87.9	84.1	77.5

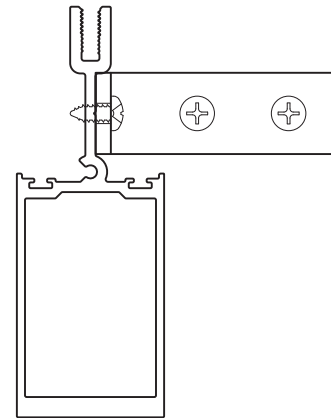

See notes 1, 2, and 3 on previous page.

BE9-4579 Unclipped 'I' Mullion Design Pressure Chart											
Maximum Design Pressure Capacity (PSF) +/- (Up to and including Florida's WZ3 - Impact) Used on YOW 225 TU / YOW 225 TUH											
Mull Span [Inches]	Tributary Width [Inches] - Frame										
	30	32	34	36	38	40	42	44	46	48	50
47	65.0	65.0	65.0	65.0	65.0	65.0	65.0	65.0	65.0	65.0	65.0
49	65.0	65.0	65.0	65.0	65.0	65.0	65.0	65.0	65.0	65.0	-
51	65.0	65.0	65.0	65.0	65.0	65.0	65.0	65.0	65.0	-	-
53	65.0	65.0	65.0	65.0	65.0	65.0	65.0	65.0	-	-	-
56	65.0	65.0	65.0	65.0	65.0	65.0	65.0	-	-	-	-
59	65.0	65.0	65.0	65.0	65.0	65.0	-	-	-	-	-
62	65.0	65.0	65.0	65.0	65.0	-	-	-	-	-	-
66	65.0	65.0	65.0	65.0	-	-	-	-	-	-	-
70	65.0	65.0	65.0	-	-	-	-	-	-	-	-
74	65.0	65.0	-	-	-	-	-	-	-	-	-
*80	65.0	-	-	-	-	-	-	-	-	-	-

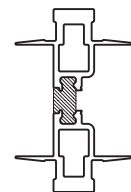

See notes 1, 2, and 3 on previous page.

* 80" Maximum Casement Frame Height 80-3/8" Maximum Fixed Frame Height or Combination Window Height

OPTIONAL SCREEN CONFIGURATIONS

**FIXED SCREEN
CASEMENT INSWING
PROJECT IN**
(INSTALLED ON EXTERIOR)

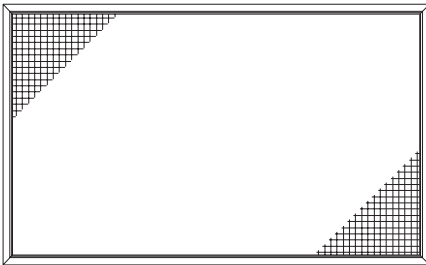
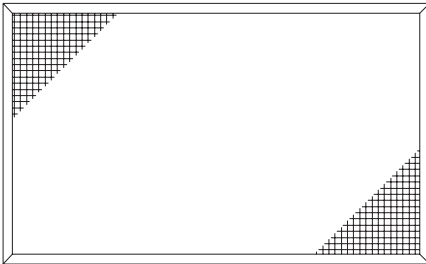

LOW PROFILE

**HINGED WICKET
PROJECT OUT**
(INSTALLED ON INTERIOR)

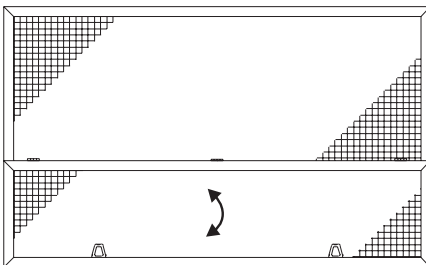

**HINGED WICKET
CASEMENT OUTSWING
(INSTALLED ON INTERIOR)**

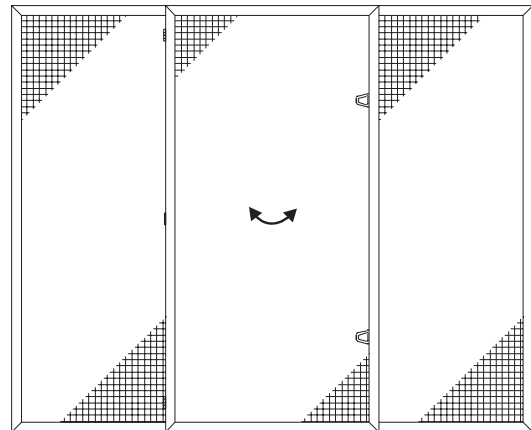
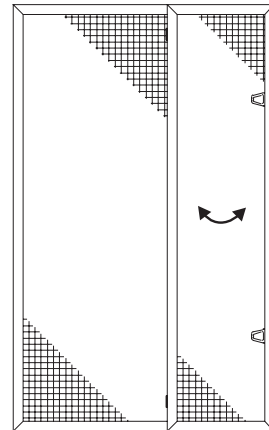

For additional information, contact YKK AP.

FIXED WINDOW SCREEN FOR INSWING (INSTALLED ON EXTERIOR)

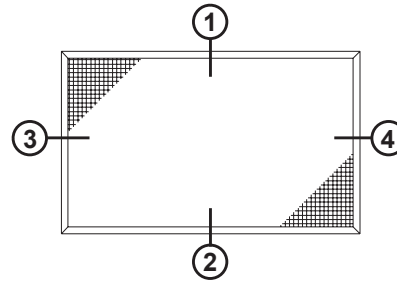
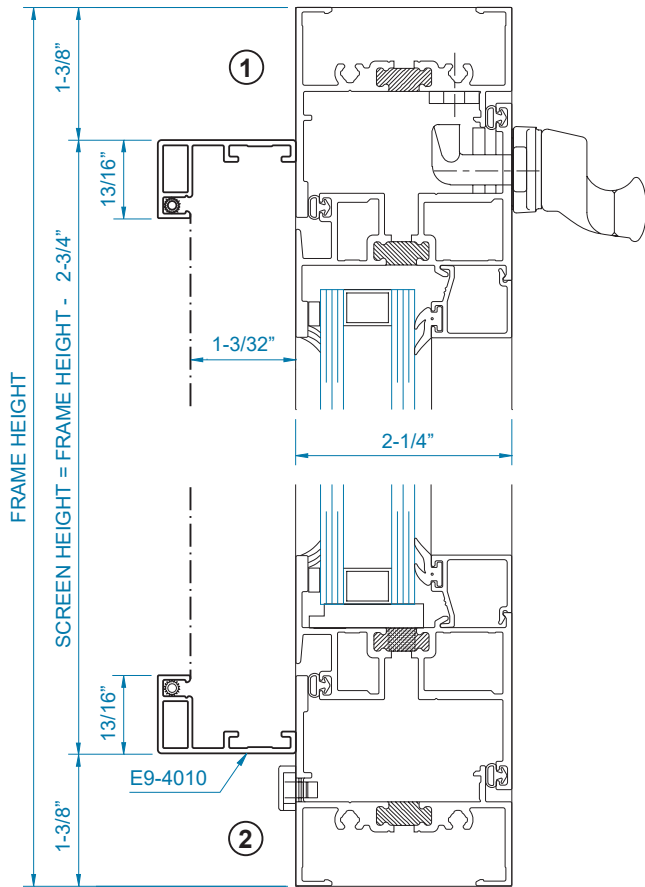

SCREEN ATTACHMENT OPTIONS

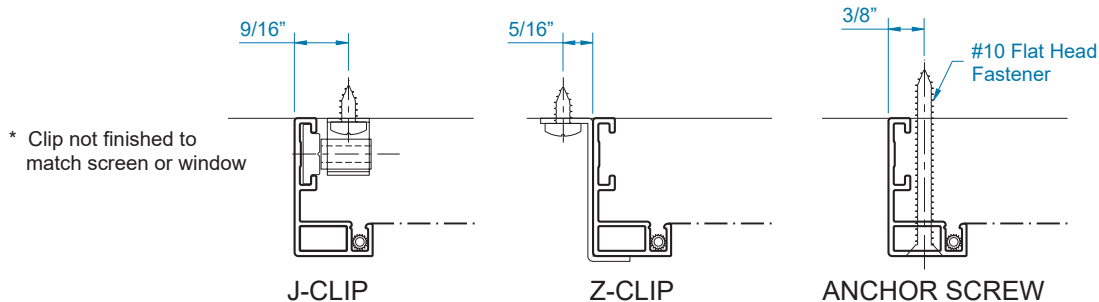
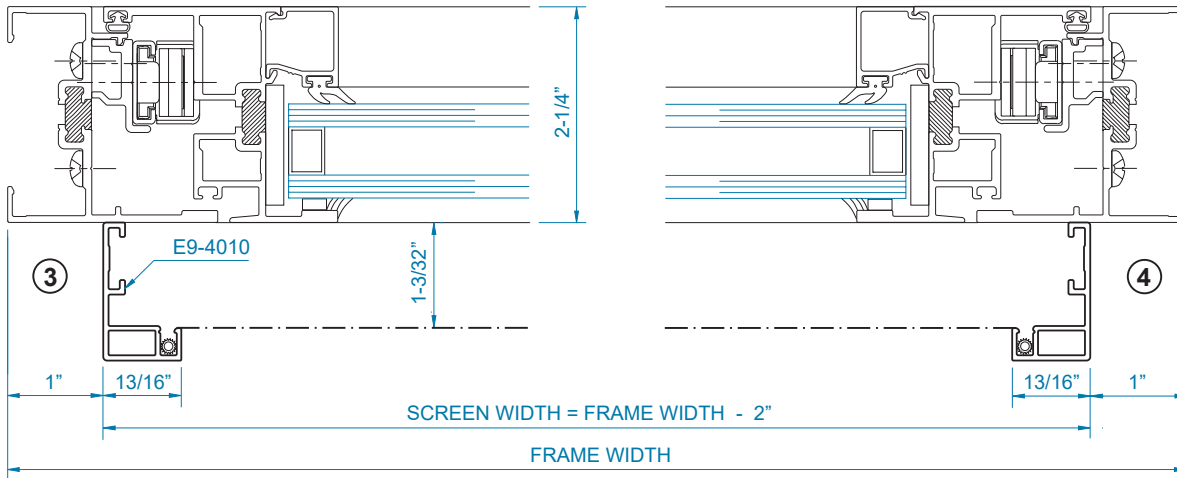
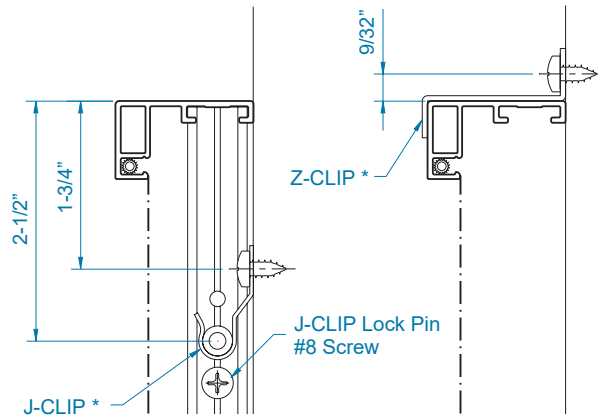

* Clip not finished to match screen or window

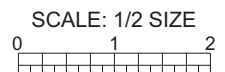

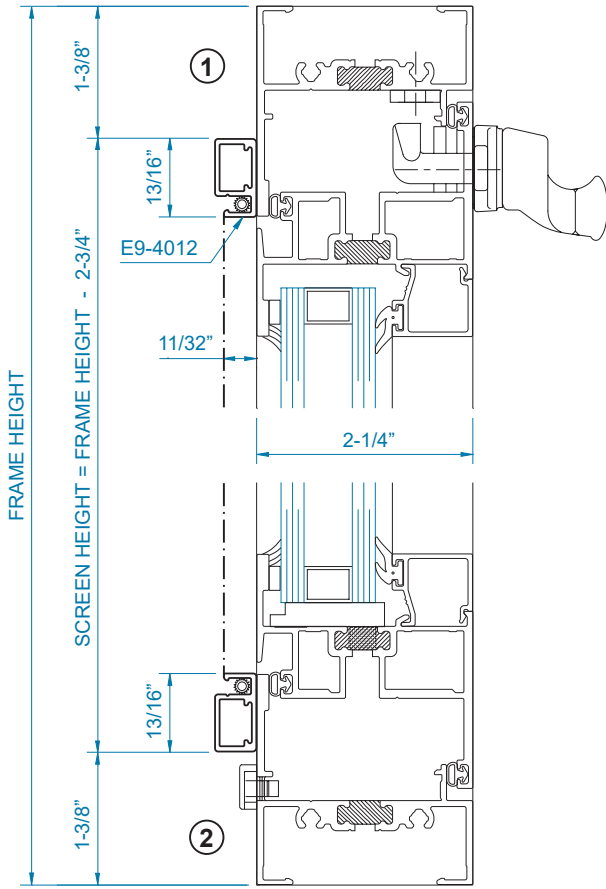

**FIXED WINDOW SCREEN FOR INSWING
LOW PROFILE
(INSTALLED ON EXTERIOR)**

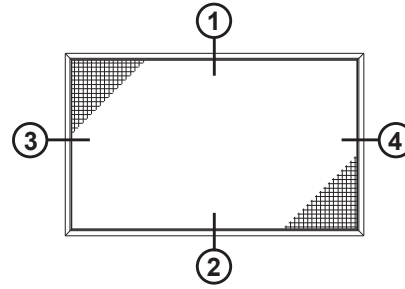

SCREEN ATTACHMENT OPTIONS

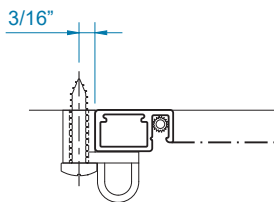
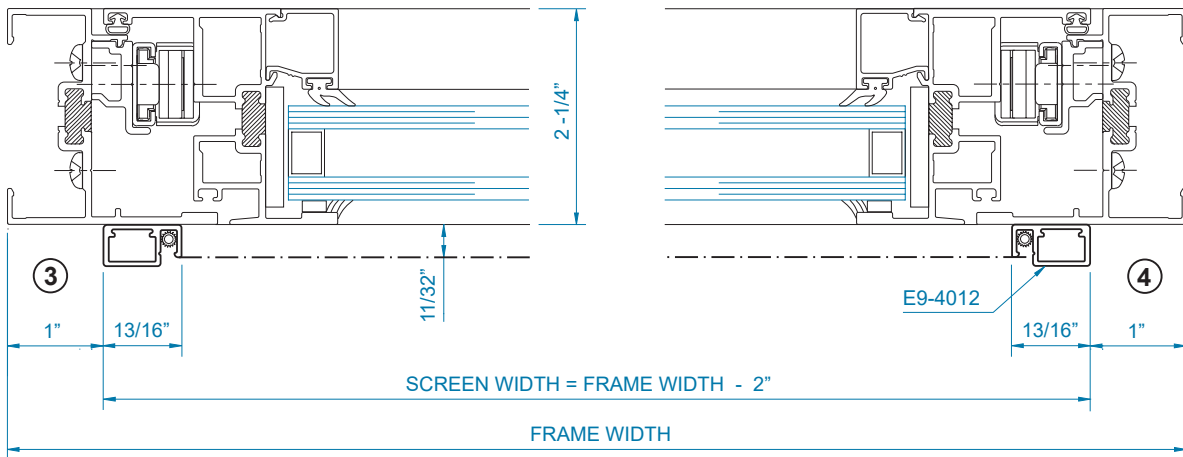
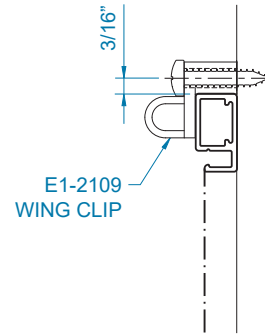

WING CLIP

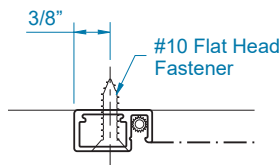

ANCHOR SCREW

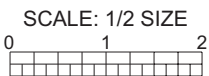

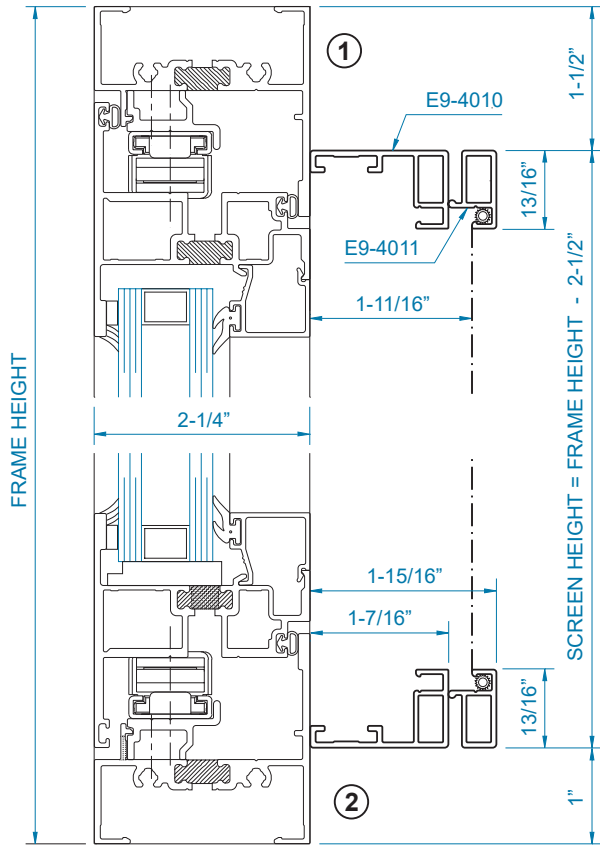

SCREEN FOR CASEMENT OUTSWING (INSTALLED ON INTERIOR)

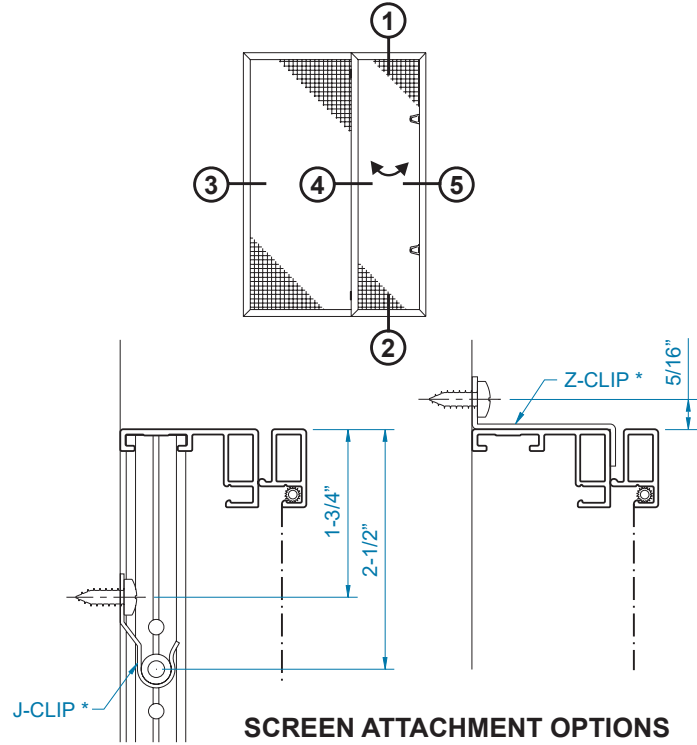

SCREEN ATTACHMENT OPTIONS

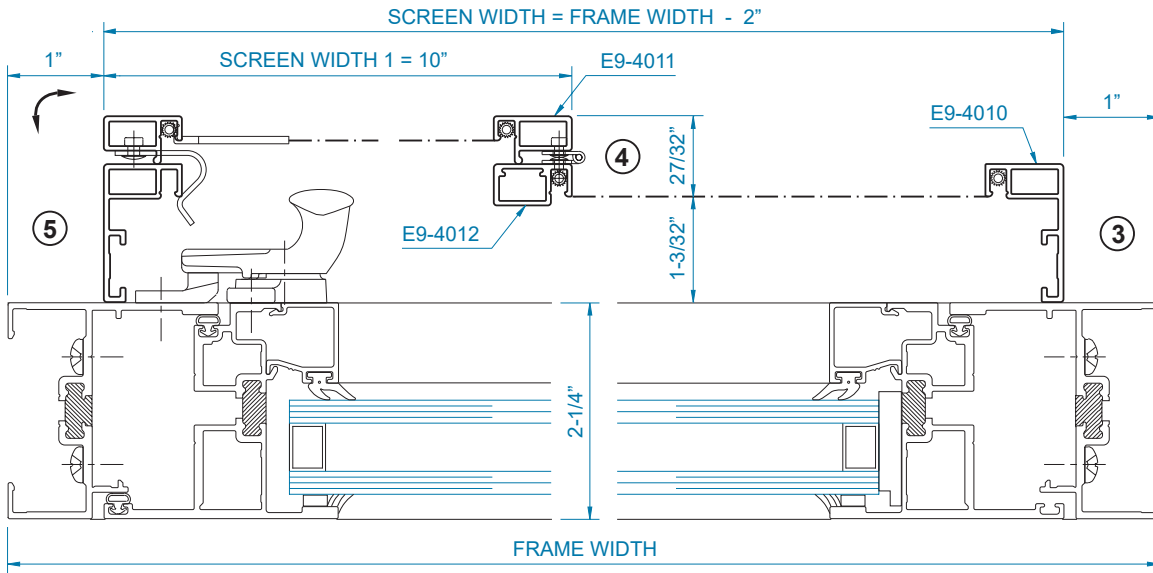

* Clip not finished to match screen or window

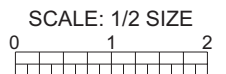
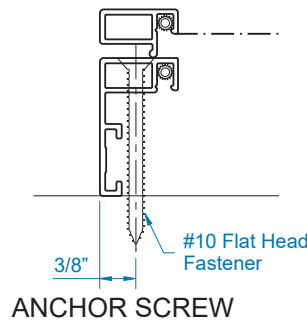
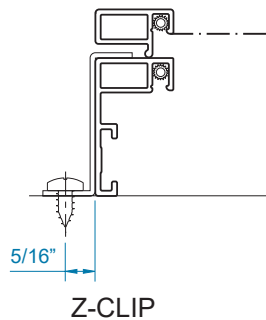
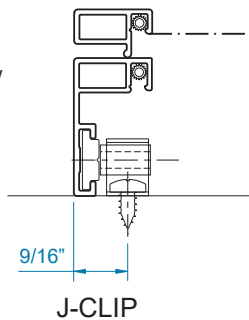

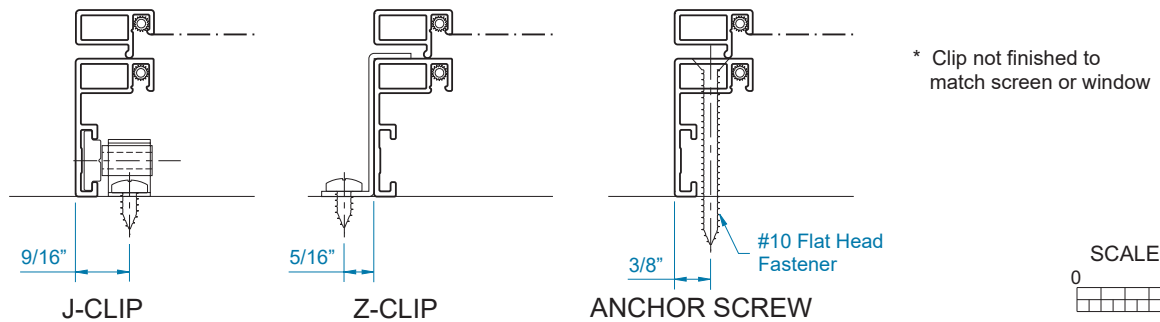
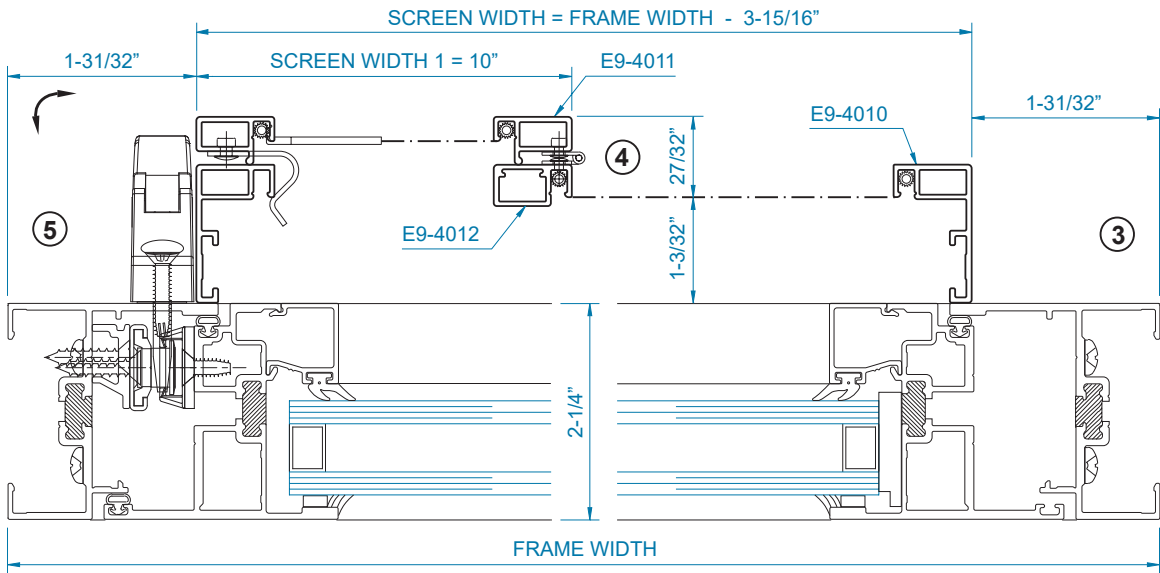
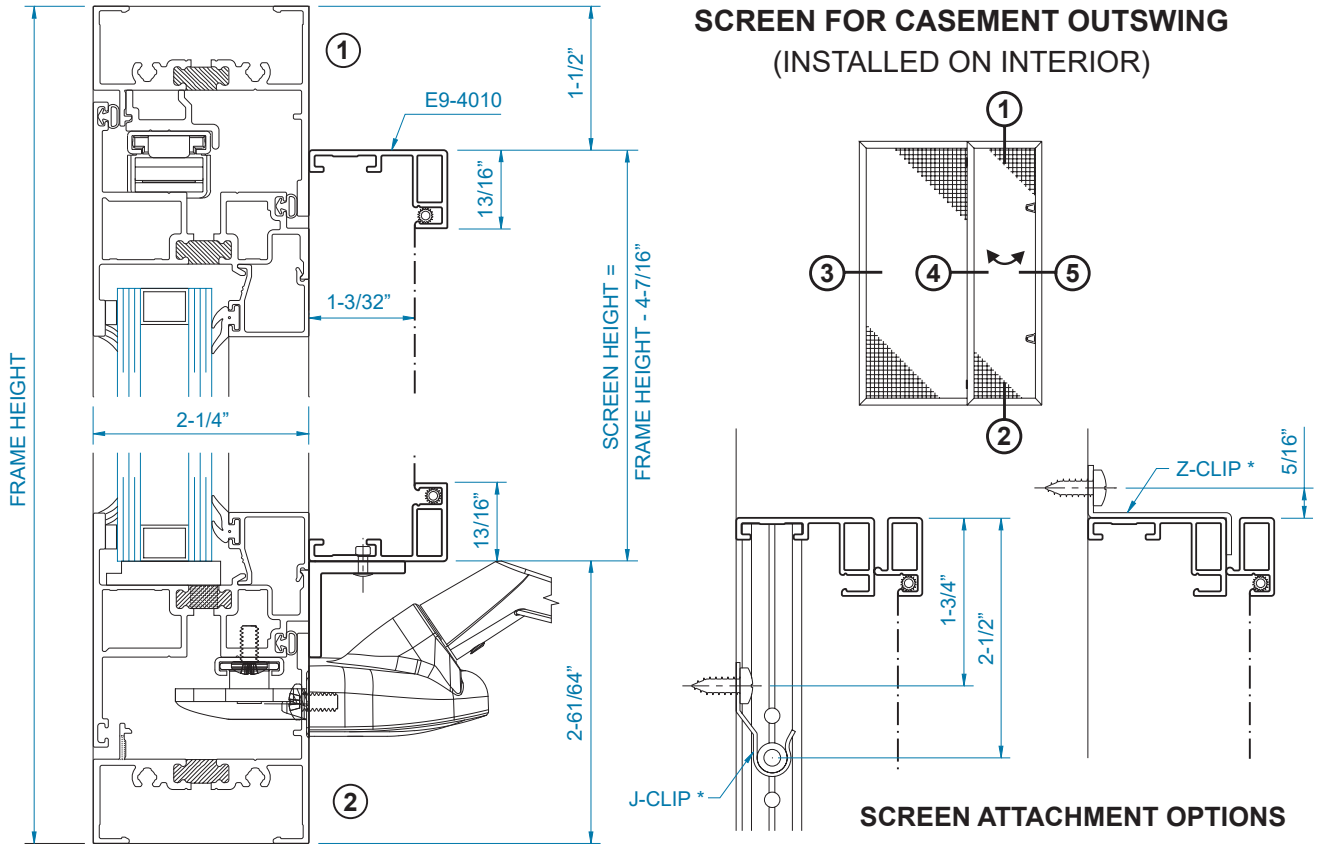

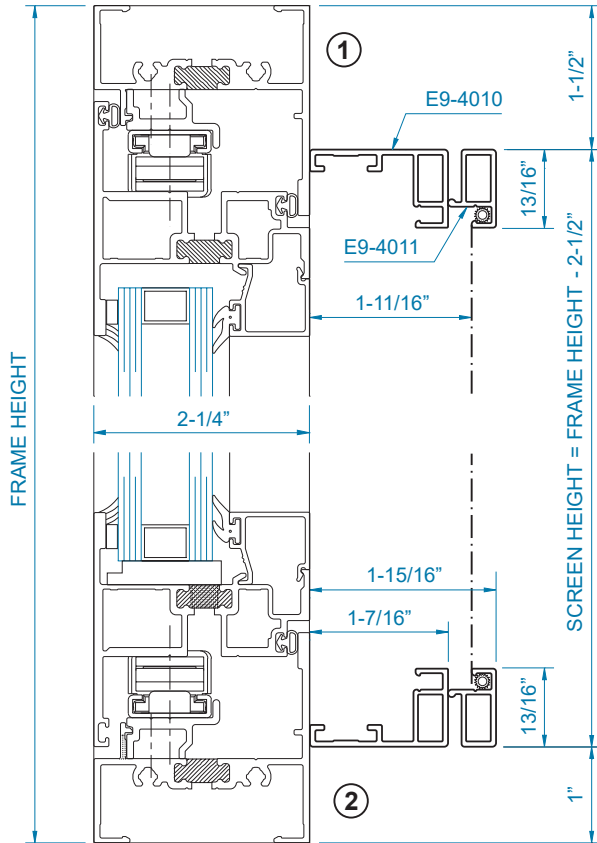

**SCREEN FOR DOUBLE CASEMENT OUTSWING
(INSTALLED ON INTERIOR)**

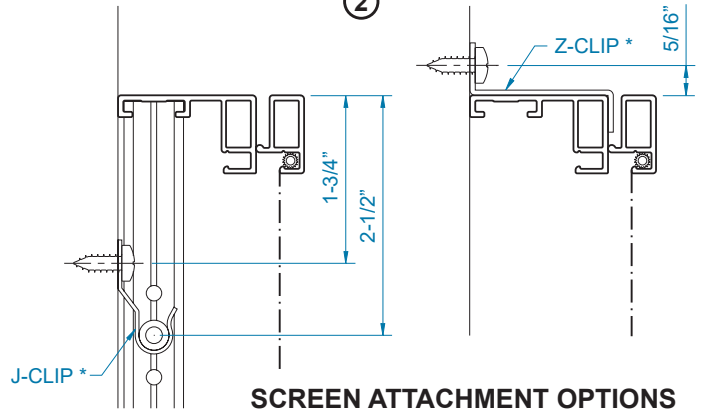
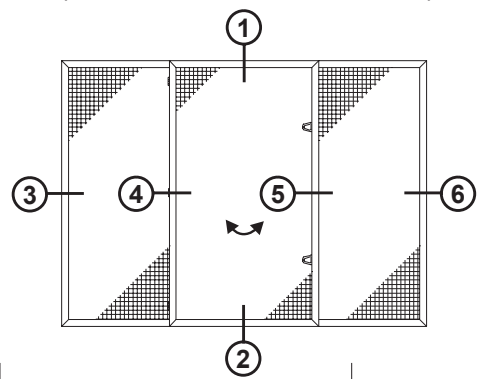

SCREEN ATTACHMENT OPTIONS

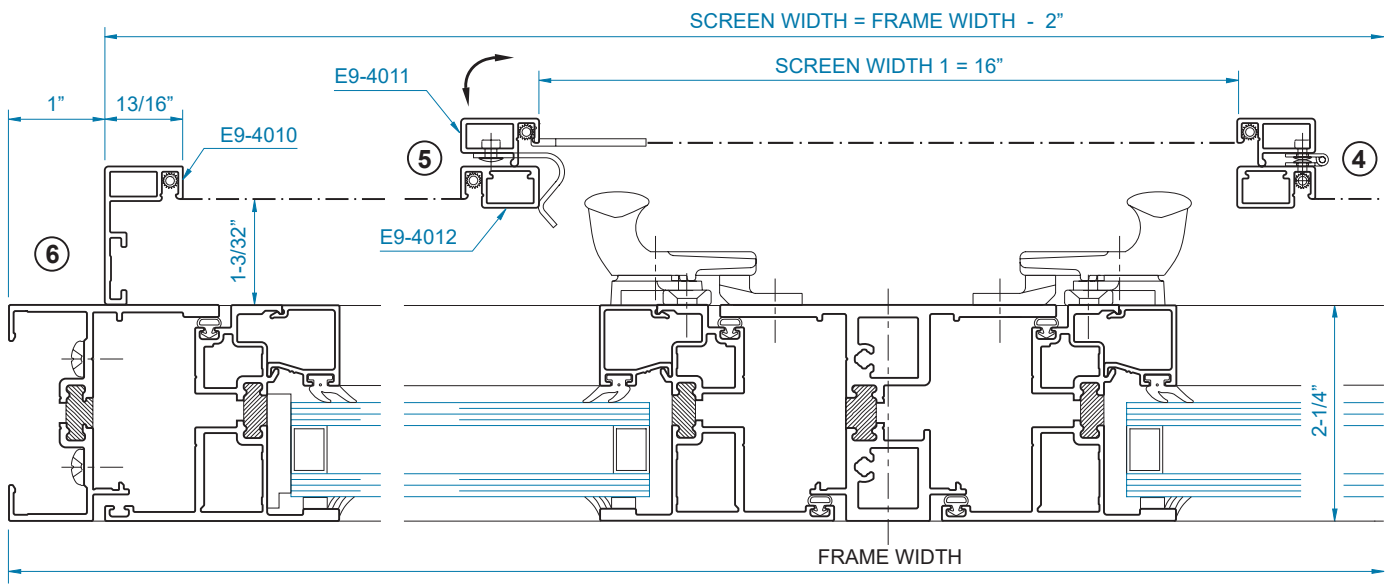

* Clip not finished to match screen or window

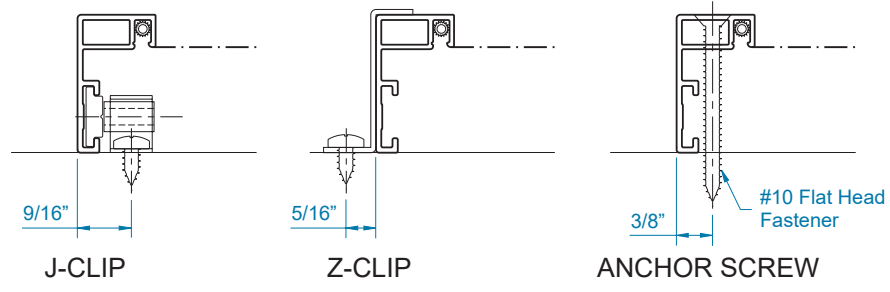
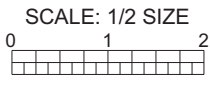

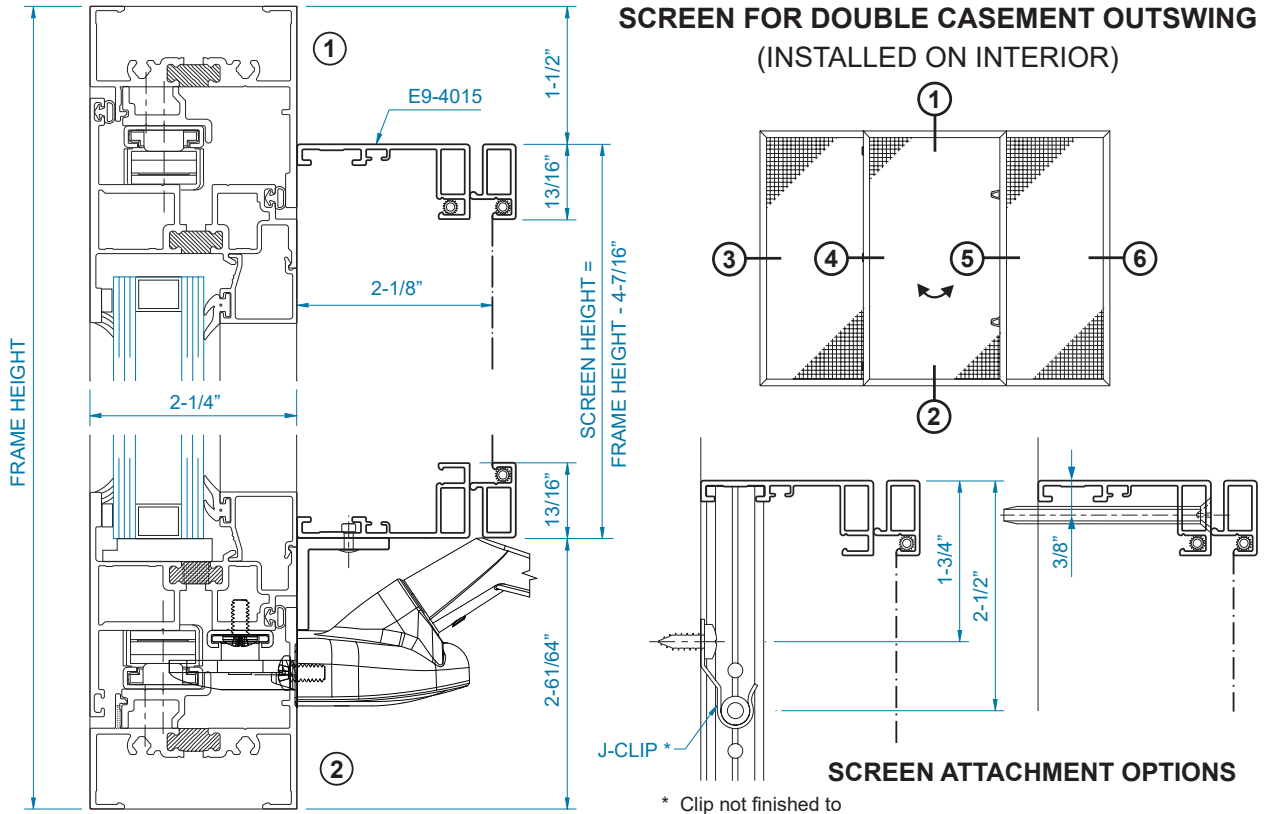

* Clip not finished to match screen or window

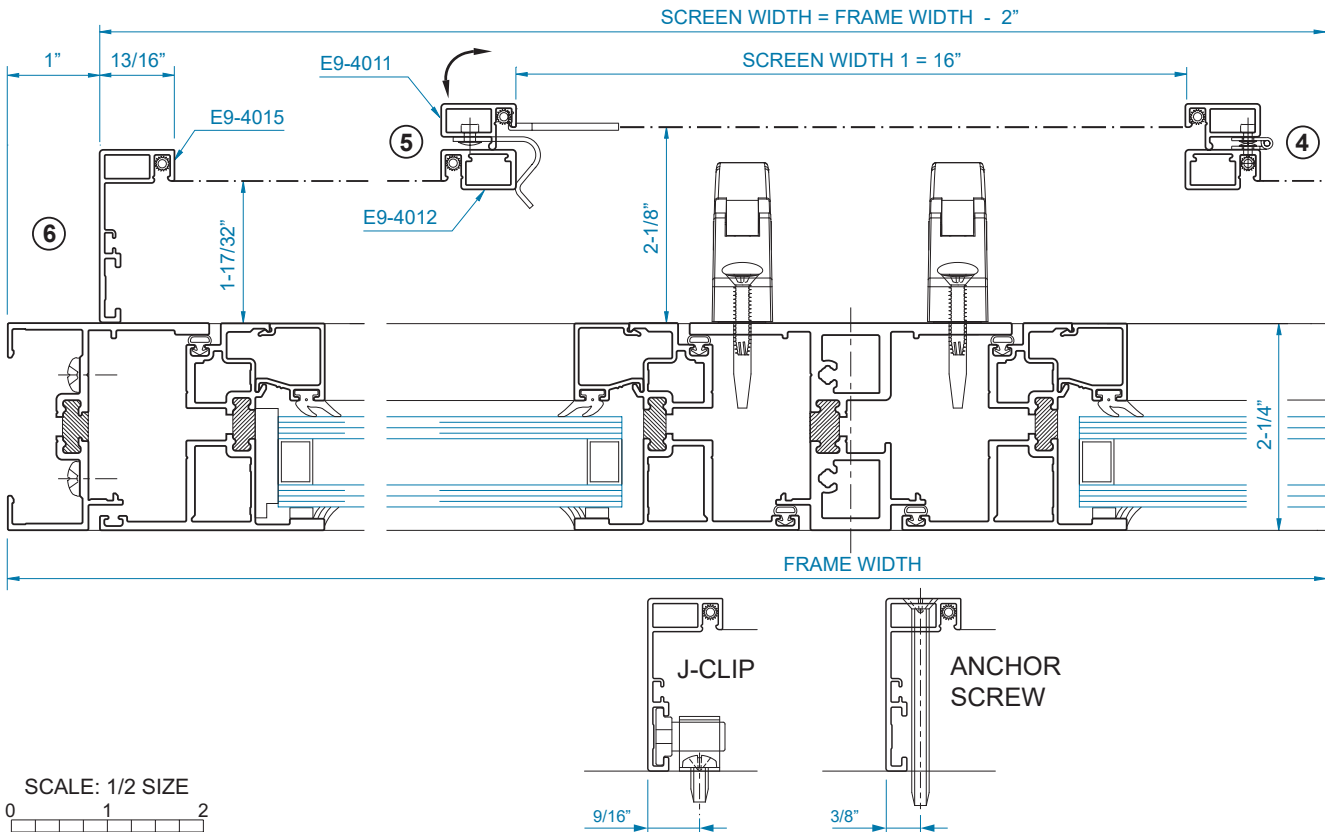

SCALE: 1/2 SIZE

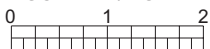

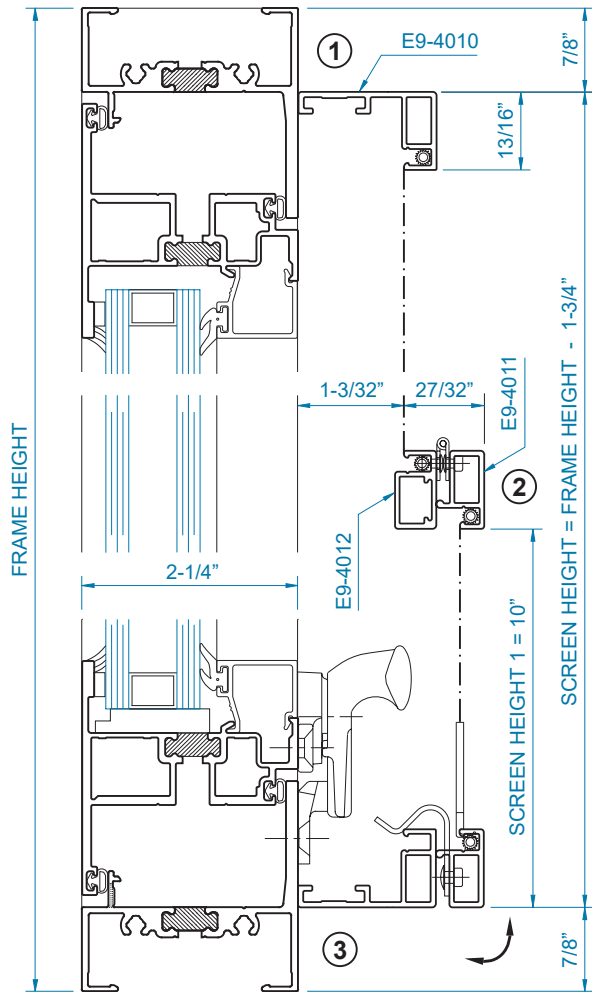

SCREEN FOR PROJECT OUT (INSTALLED ON INTERIOR)

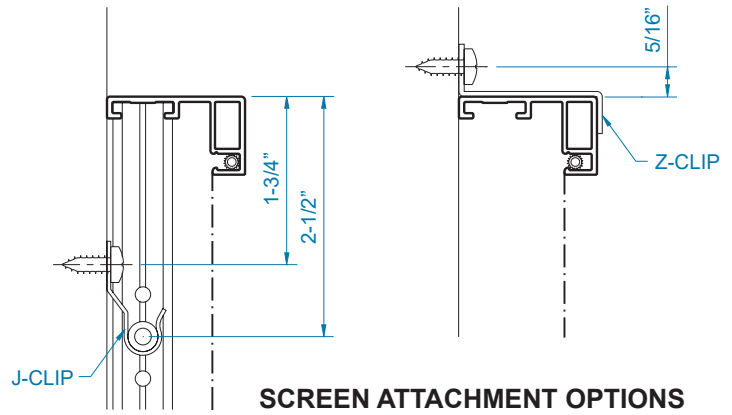
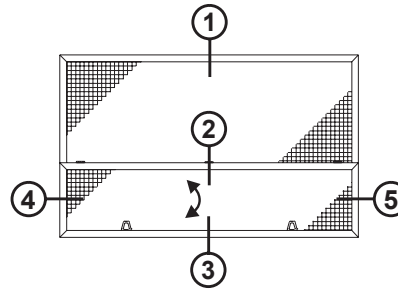

SCREEN ATTACHMENT OPTIONS

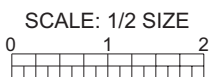
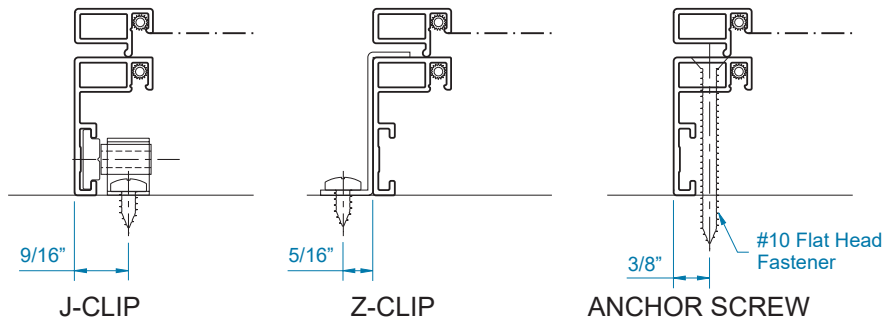
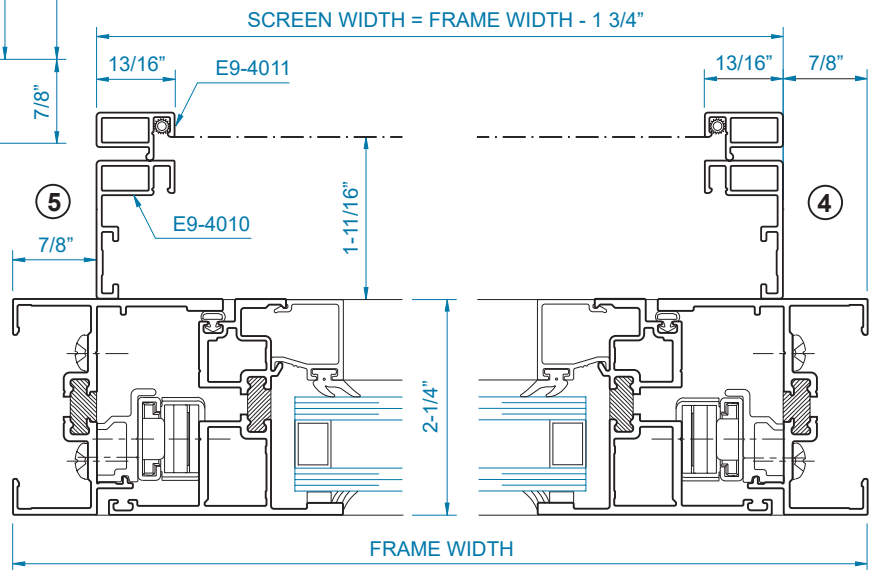

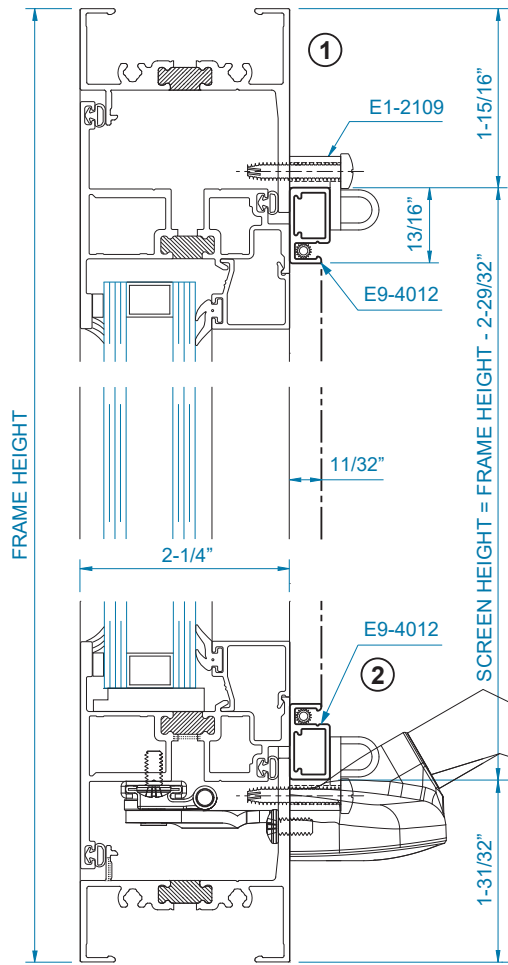

**SCREEN FOR PROJECT OUT
LOW PROFILE
(INSTALLED ON INTERIOR, SHOWN
WITH ROTO-OPERATOR & FMPL)**

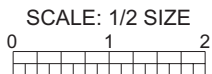
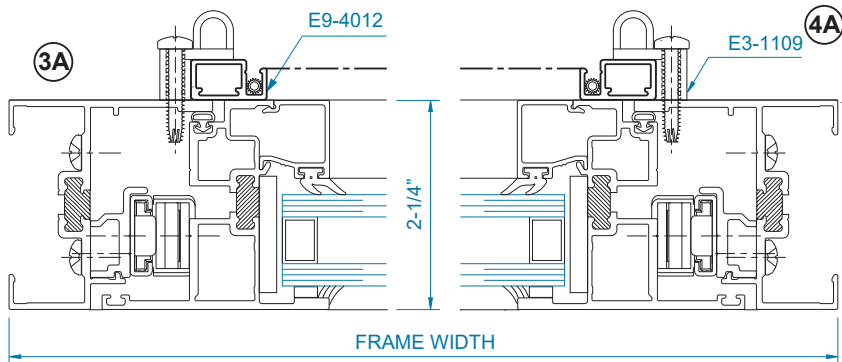
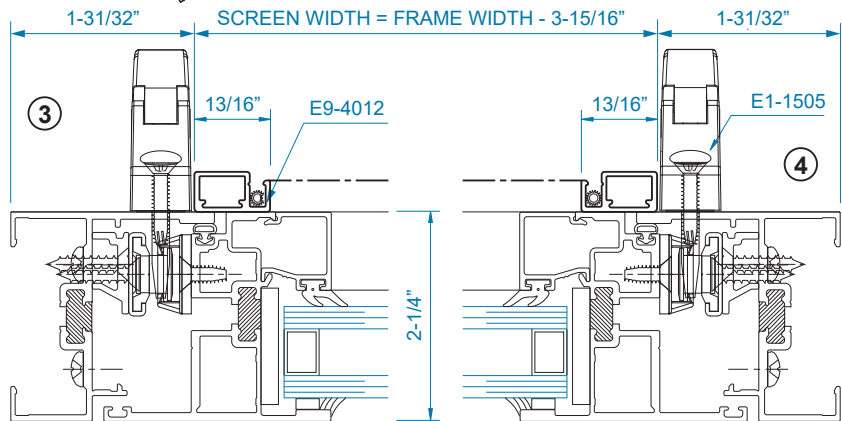
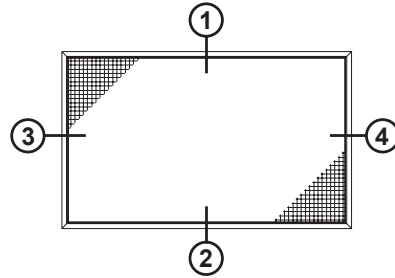

FIXED WINDOW

1. SIZE LIMITATIONS: (Based on AW-100 Designation)

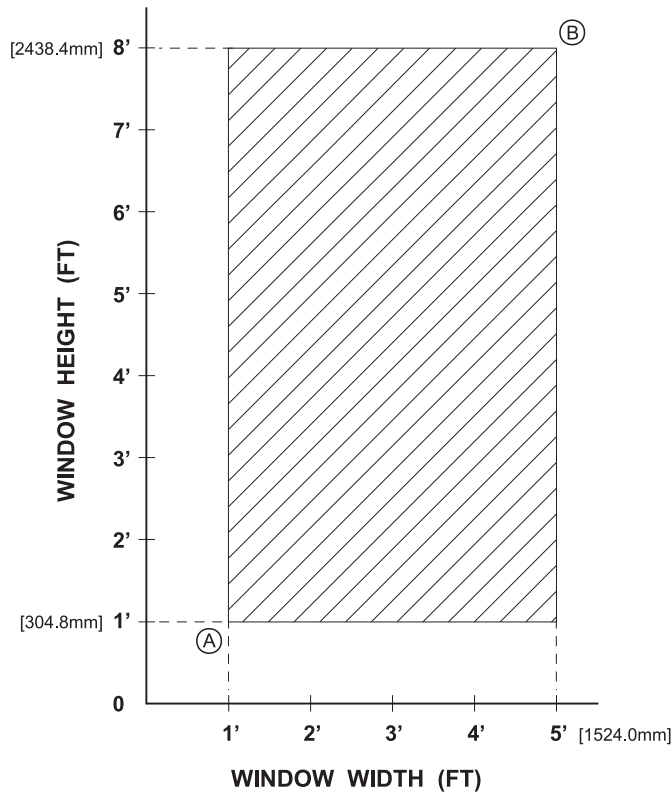

	WINDOW WIDTH	WINDOW HEIGHT
Ⓐ	MINIMUM SIZE 12" [304.8mm]	12" [304.8mm]
Ⓑ	MAXIMUM SIZE 60" [1524.0mm]	96" [2438.4mm]

CASEMENT INSWING

1. SIZE LIMITATIONS: (Based on AW-65 Designation)

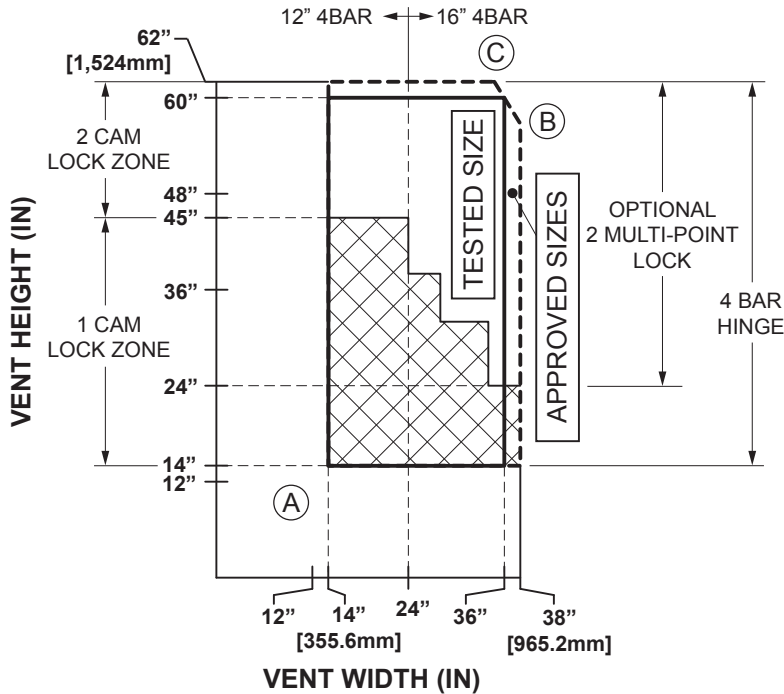

	VENT WIDTH	VENT HEIGHT
Ⓐ	MINIMUM SIZE 14" [355.6mm]	14" [355.6mm]
Ⓑ	MAXIMUM SIZE 38" [965.2mm]	56-3/4" [1,441.5mm]
Ⓒ	MAXIMUM SIZE 34-3/4" [882.7mm]	62" [1,574.8mm]
ONE CAM LOCK LIMITS		
	24" [609.6mm]	45" [1,143mm]
	28" [711.2mm]	38" [965.2mm]
	34" [863.6mm]	32" [812.8mm]
	38" [965.2mm]	24" [609.6mm]

MAXIMUM SQUARE FOOTAGE
FOR ±65 PSF = 15 SQ. FT.

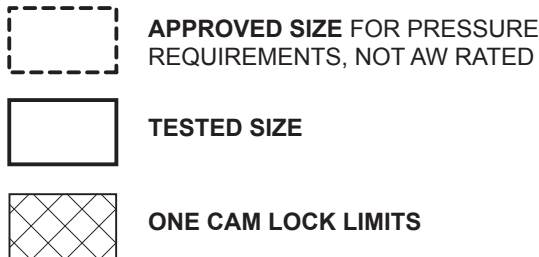

2. FOUR BAR HINGE USAGE

PART NO.	LENGTH	VENT WIDTH	MAX. WEIGHT	MAX. OPENING ANGLE
4K-14207	12"	≤ 24" [609.6mm]	83lbs [38.0kg]	90°
4K-14208	16"	> 24" [609.6mm]	117lbs [53.0kg]	90°

ACCESSIBLE WINDOW CASEMENT INSWING

1. SIZE LIMITATIONS: (Based on DP-45 Designation. Meets AAMA 513-44 Forces and Motion for Windows in Accessible Spaces)

VENT WIDTH	VENT HEIGHT	VENT AREA	ALLOWABLE DESIGN PRESSURE
MINIMUM SIZE (BUTT HINGE ONLY)			
Ⓐ 14-1/8" [358.8mm]	17-1/4" [438.2mm]	1.7 sq. ft.	65 psf
MINIMUM SIZE (4-BAR HINGE ONLY)			
Ⓑ 16" [406.4mm]	17-1/4" [438.2mm]	1.9 sq. ft.	65 psf
APPROVED SIZES			
Ⓒ 35" [889.0mm]	59-1/4" [1505.0mm]	14.3 sq. ft.	65 psf
Ⓓ 36" [914.4mm]	63-1/8" [1603.4mm]	15.7 sq. ft.	60 psf
Ⓔ 37" [939.8mm]	67" [1701.8mm]	17.2 sq. ft.	55 psf
Ⓕ 37-1/2" [952.5mm]	71-1/4" [1809.8mm]	18.6 sq. ft.	50 psf
TESTED SIZE			
Ⓖ 38" [965.2mm]	76" [1930.4mm]	20.1 sq. ft.	45 psf
MAXIMUM SIZE			
* Ⓖ 37" [939.8mm]	78" [1981.2mm]	20.0 sq. ft.	45 psf

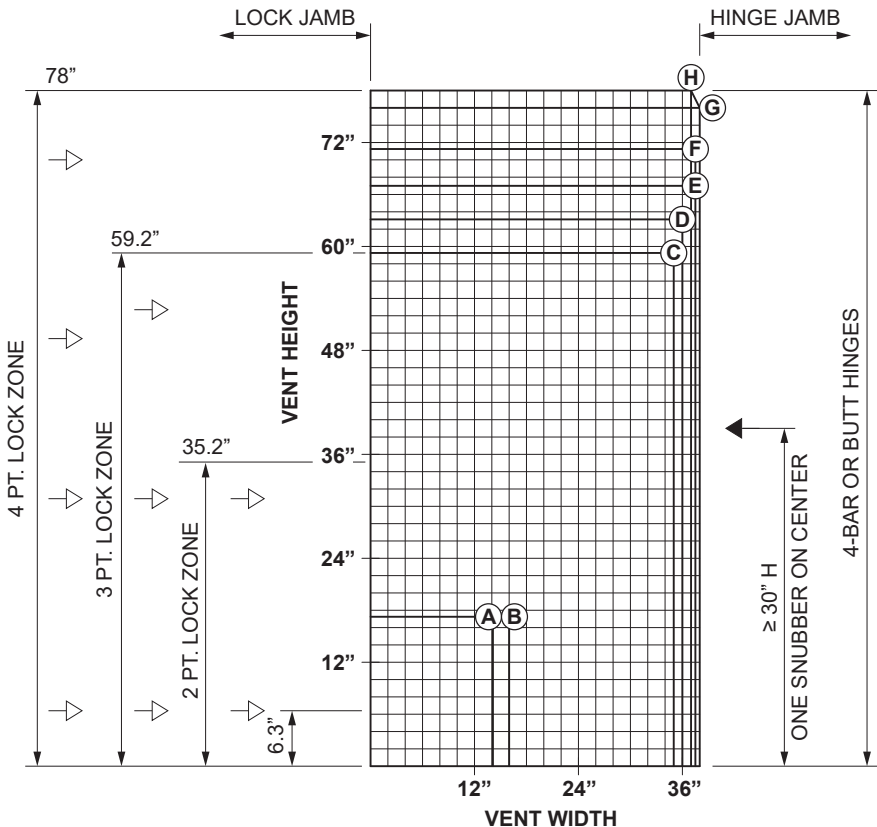

Note: NYC limit devices available for vents wider than 20".

* Approved size for pressure requirements, not AW rated.

▷ LOCK POINT
◀ SNUBBER

CASEMENT OUTSWING

1. SIZE LIMITATIONS: (Based on AW-65 Designation)

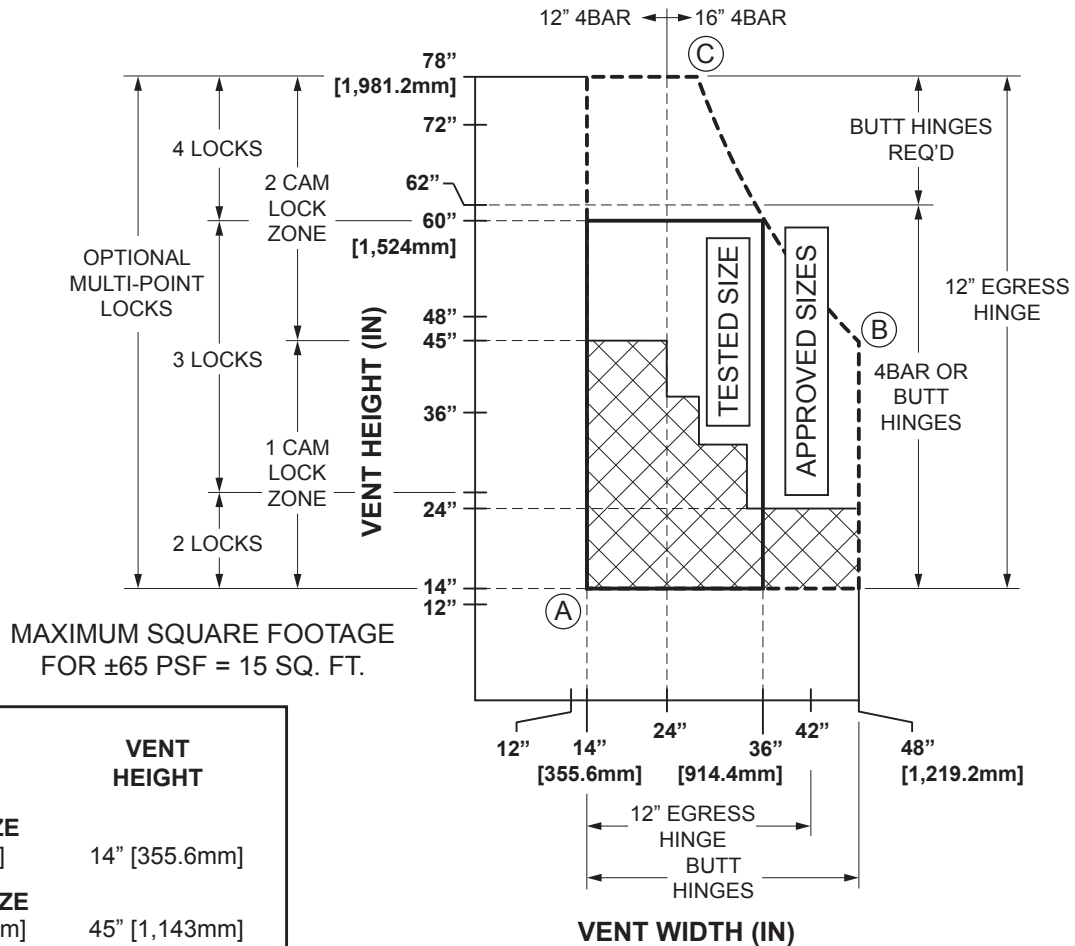

VENT WIDTH	VENT HEIGHT
(A) MINIMUM SIZE 14" [355.6mm]	14" [355.6mm]
(B) MAXIMUM SIZE 48" [1,219.2mm]	45" [1,143mm]
(C) MAXIMUM SIZE 27-5/8" [701.7mm]	78" [1,981.2mm]
ONE CAM LOCK LIMITS	
24" [609.6mm]	45" [1,143mm]
28" [711.2mm]	38" [965.2mm]
34" [863.6mm]	32" [812.8mm]
48" [1,219.2mm]	24" [609.6mm]

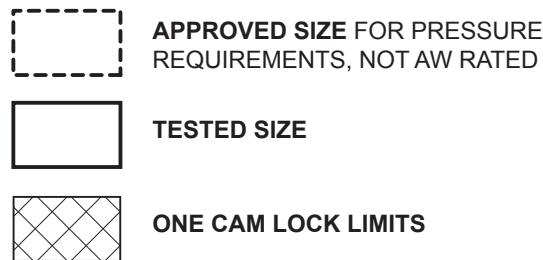

PART NO.	LENGTH	VENT WIDTH	MAX. WEIGHT	MAX. OPENING ANGLE
4K-14207	12"	≤ 24" [609.6mm]	83lbs [38.0kg]	90°
4K-14208	16"	> 24" [609.6mm]	117lbs [53.0kg]	90°
E1-1957	12" Egress	> 13" [330.2mm]	170lbs [77.1kg]	90°

ACCESSIBLE WINDOW CASEMENT OUTSWING

1. SIZE LIMITATIONS: (Based on AW-65 & DP-45 Designation. Meets AAMA 513-14 Forces and Motion for Windows in Accessible Spaces.)

VENT WIDTH	VENT HEIGHT	VENT AREA	ALLOWABLE DESIGN PRESSURE
MINIMUM SIZE (BUTT HINGE ONLY)			
Ⓐ 14-1/8" [358.8mm]	17-1/4" [438.2mm]	1.7 sq. ft.	65 psf
MINIMUM SIZE (4-BAR HINGE ONLY)			
Ⓑ 25" [635.0mm]	17-1/4" [438.2mm]	3.0 sq. ft.	65 psf
APPROVED SIZES			
* Ⓓ 36" [914.4mm]	63-1/8" [1603.4mm]	15.7 sq. ft.	60 psf
* Ⓔ 37" [939.8mm]	67" [1701.8mm]	17.2 sq. ft.	55 psf
* Ⓕ 37-1/2" [952.5mm]	71-1/4" [1809.8mm]	18.6 sq. ft.	50 psf
TESTED SIZE			
Ⓒ 35" [889.0mm]	59" [1498.6mm]	14.3 sq. ft.	65 psf
Ⓖ 38" [965.2mm]	76" [1930.4mm]	20.1 sq. ft.	45 psf
MAXIMUM SIZE			
* Ⓖ 37" [939.8mm]	78" [1981.2mm]	20.0 sq. ft.	45 psf

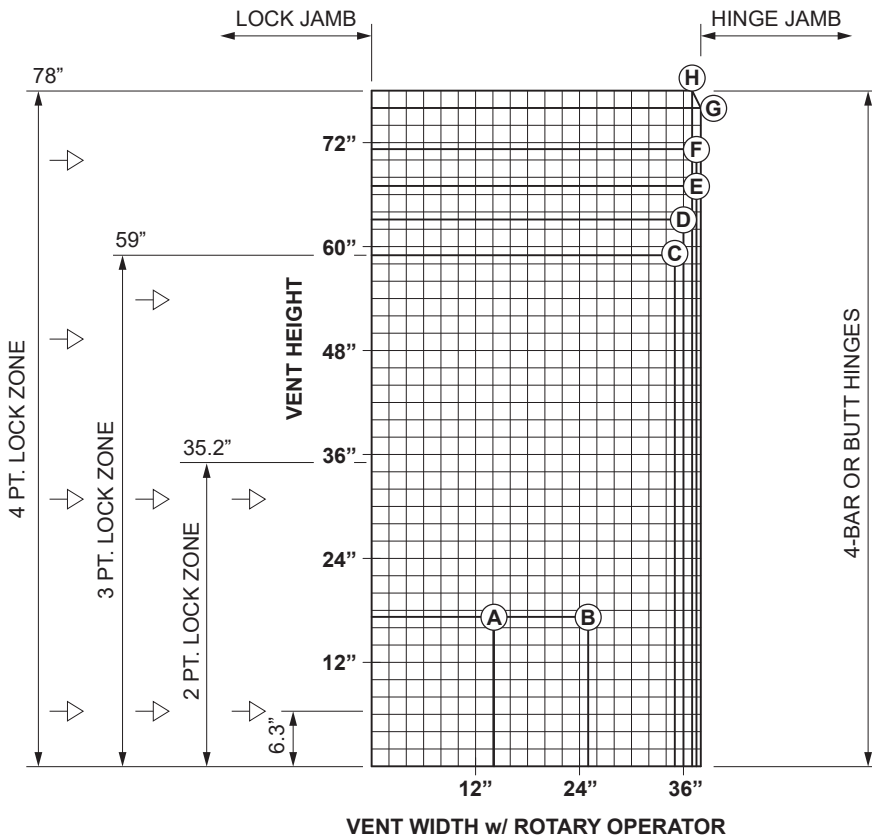

Notes: Please contact YKK AP's Engineering Center for size restrictions when using 4-Bar Hinges and/or Limit Devices.

* Approved size for pressure requirements, not AW rated.

PROJECT IN

1. SIZE LIMITATIONS: (Based on AW-65 Designation)

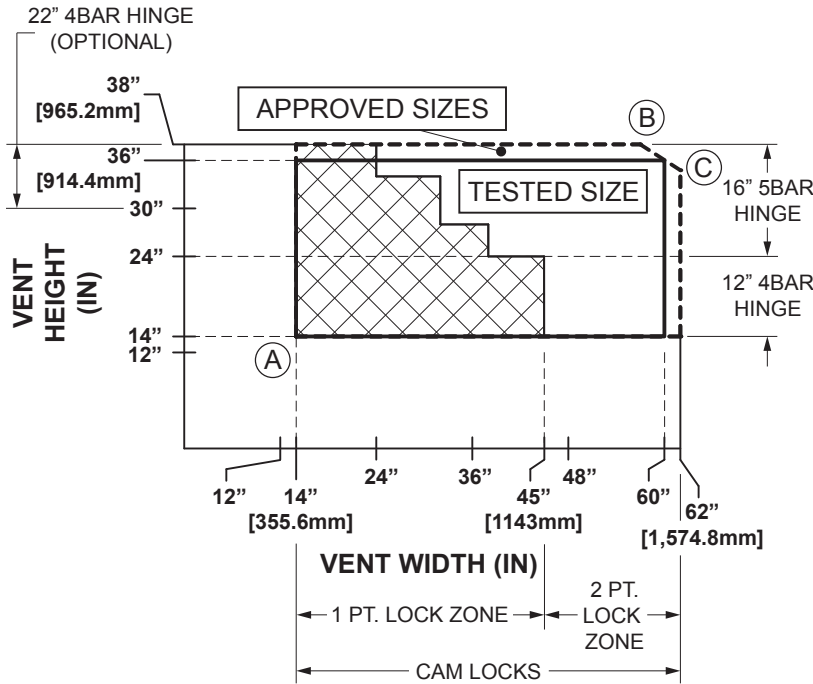

	VENT WIDTH	VENT HEIGHT
(A) MINIMUM SIZE	14" [355.6mm]	14" [355.6mm]
(B) MAXIMUM SIZE	56-3/4" [1,441.5mm]	38" [965.2mm]
(C) MAXIMUM SIZE	62" [1,574.8mm]	34-3/4" [882.7mm]
ONE CAM LOCK LIMITS		
	45" [1,143mm]	24" [609.6mm]
	38" [965.2mm]	28" [711.2mm]
	32" [812.8mm]	34" [863.6mm]
	24" [609.6mm]	38" [965.2mm]

MAXIMUM SQUARE FOOTAGE
FOR ±65 PSF = 15 SQ. FT.

- APPROVED SIZE FOR PRESSURE REQUIREMENTS, NOT AW RATED**
- TESTED SIZE**
- ONE CAM LOCK LIMITS**

2. FOUR BAR HINGE USAGE

PART NO.	LENGTH	VENT HEIGHT	MAX. WEIGHT	MAX. OPENING ANGLE
4K-14207	12"	≤ 24" [609.6mm]	90 lbs [40.8kg]	20° w/ Limit Stop
5K-15284	16"	> 24" [609.6mm]	130 lbs [59.0kg]	30° w/o Limit Stop
4K-14209	22"	> 30" [762.0mm]	140 lbs [63.5kg]	45° w/ Limit Stop

PROJECT OUT

1. SIZE LIMITATIONS: (Based on AW-65 Designation)

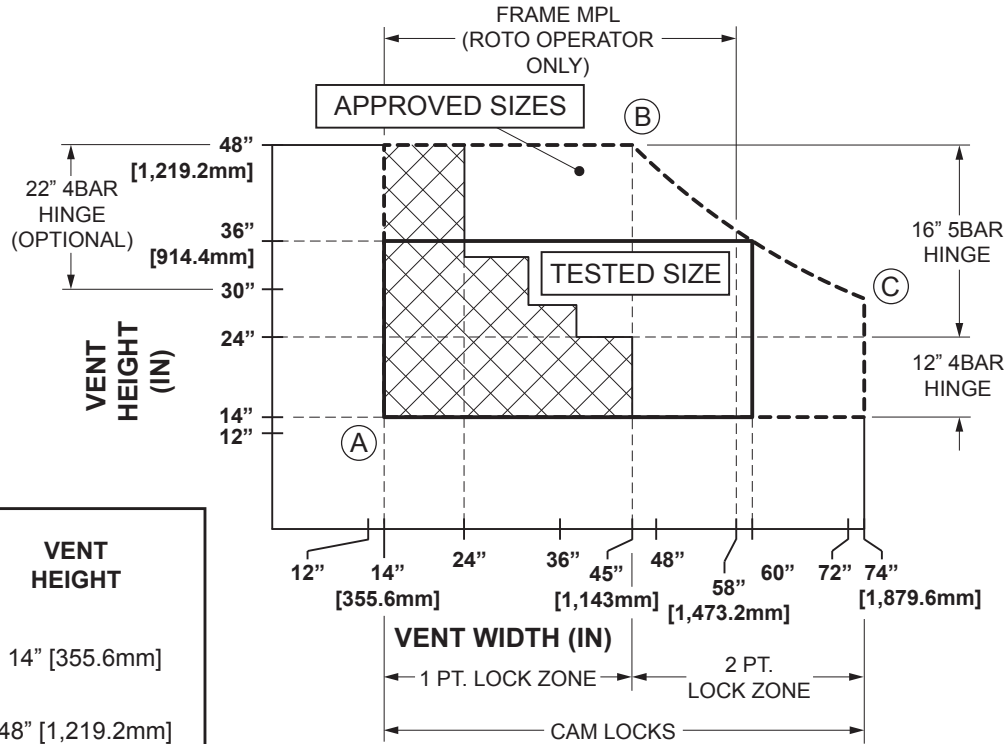

	VENT WIDTH	VENT HEIGHT
(A) MINIMUM SIZE	14" [355.6mm]	14" [355.6mm]
(B) MAXIMUM SIZE	45" [1,143mm]	48" [1,219.2mm]
(C) MAXIMUM SIZE	74" [1,879.6mm]	29-3/16" [741.4mm]
ONE CAM LOCK LIMITS		
	45" [1,143mm]	24" [609.6mm]
	38" [965.2mm]	28" [711.2mm]
	32" [812.8mm]	34" [863.6mm]
	24" [609.6mm]	48" [1,219.2mm]

MAXIMUM SQUARE FOOTAGE FOR ±65 PSF = 15 SQ. FT.

- APPROVED SIZE FOR PRESSURE REQUIREMENTS, NOT AW RATED**
- TESTED SIZE**
- ONE CAM LOCK LIMITS**

2. FOUR BAR HINGE USAGE

PART NO.	LENGTH	VENT HEIGHT	MAX. WEIGHT	MAX. OPENING ANGLE
4K-14207	12"	≤ 24" [609.6mm]	90 lbs [40.8kg]	20° w/ Limit Stop
5K-15284	16"	> 24" [609.6mm]	130 lbs [59.0kg]	30° w/o Limit Stop
4K-14209	22"	> 30" [762.0mm]	140 lbs [63.5kg]	45° w/ Limit Stop

ACCESSIBLE WINDOW PROJECT OUT

- 1. SIZE LIMITATIONS:** (Based on AW-45 Rating, Oversize 22.7 sq.ft. max.)
 (AW-65 Rating 15 sq.ft. max.)
 Meets AAMA 513-14 Forces and Motion for Windows in Accessible Places.)

VENT WIDTH	VENT HEIGHT	VENT AREA	ALLOWABLE DESIGN PRESSURE	VENT WEIGHT @ 7.2 lbs PER SQ. FT.
MINIMUM SIZE				
Ⓐ 23" [584.2mm]	25" [635.0mm]	4.0 sq. ft.	65 psf	28.8 lbs
Ⓑ 30" [762.0mm]	48" [1219.2mm]	10.0 sq. ft.	65 psf	72.0 lbs
Ⓒ 36" [914.4mm]	60" [1524.0mm]	15.0 sq. ft.	65 psf	108.0 lbs
Ⓓ 39" [990.6mm]	69" [1752.6mm]	18.7 sq. ft.	55 psf	134.6 lbs
MAXIMUM TESTED SIZE				
Ⓔ 42" [1066.8mm]	78" [1981.2mm]	22.7 sq. ft.	45 psf	163.4 lbs.

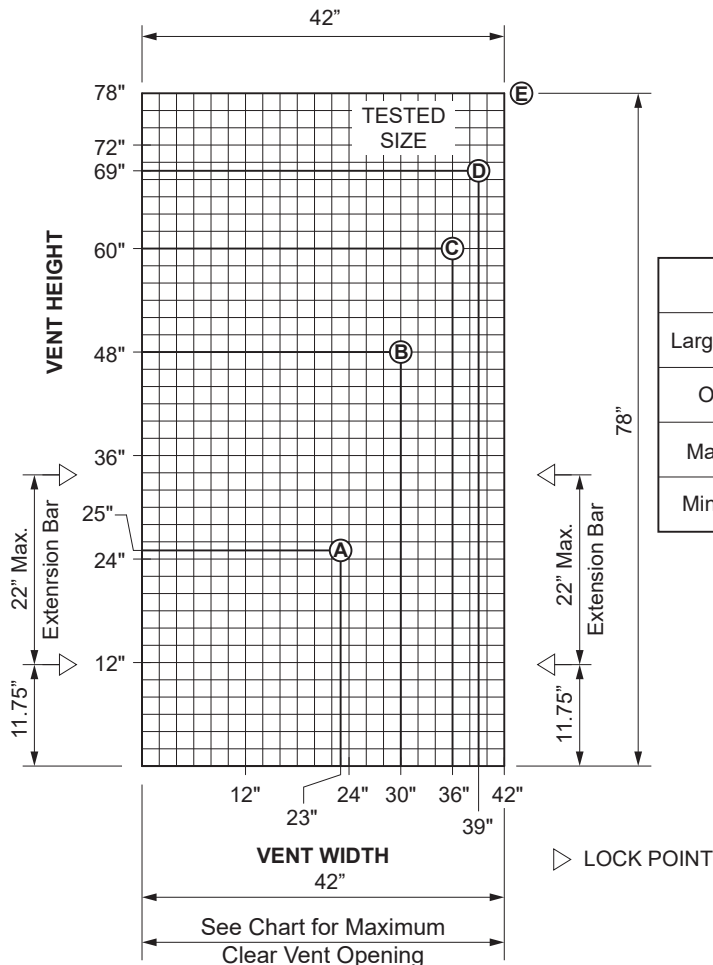

Operator Part #	*E1-1991	*E1-2012	E1-2013	E1-1992
Large Handle Crank Part #	E1-1983	E1-1983	E1-1983	E1-1983
Operator Arm Length	5-1/2"	7"	9"	11"
Maximum Vent Opening	1-3/16"	2-11/16"	4-11/16"	6-11/16"
Minimum Vent Cut Width	23"	26"	30"	34"

* E1-1991 & E1-2012 rotary operators cannot be used in NYC, if NYC limit devices are used.

YOW 225 TU HARDWARE GUIDE

	DESCRIPTION	CASEMENT OUT	CASEMENT IN	PROJECT OUT	PROJECT IN
LOCKING HARDWARE	CAM HANDLES	STANDARD	STANDARD	STANDARD	STANDARD
	CUSTODIAL CAM LOCK (HEX KEY)	OPTIONAL	OPTIONAL	OPTIONAL	OPTIONAL
	MULTI-LOCK HANDLE	OPTIONAL	OPTIONAL	OPTIONAL	
	CUSTODIAL MULTI-LOCK (HEX KEY)	OPTIONAL	OPTIONAL	OPTIONAL	
	POLE RING LOCKS	OPTIONAL	OPTIONAL	OPTIONAL	OPTIONAL
HINGE & LIMIT STOP HARDWARE	4 BAR HINGES	STANDARD	STANDARD	STANDARD	STANDARD
	BUTT HINGES	OPTIONAL	OPTIONAL		
	FRICTION ADJUSTERS	STANDARD W/ BUTT HINGES	STANDARD W/ BUTT HINGES		
	ROTO-OPERATOR	OPTIONAL W/ BUTT HINGES		OPTIONAL	
	4-BAR EGRESS HINGES	OPTIONAL			
	LIMIT STOP IN 4-BAR HINGE ONLY	OPTIONAL	OPTIONAL	OPTIONAL	OPTIONAL
	KEYED LIMIT DEVICE	OPTIONAL	OPTIONAL	OPTIONAL	OPTIONAL
	4" LIMIT DEVICE (APPROVED FOR NEW YORK CITY)	OPTIONAL		OPTIONAL	
	SCREENS	OPTIONAL	OPTIONAL	OPTIONAL	OPTIONAL

ACCESSIBLE WINDOW HARDWARE GUIDE

	DESCRIPTION	CASEMENT IN 4-BAR HINGE	CASEMENT IN BUTT HINGE	CASEMENT OUT 4-BAR HINGE	CASEMENT OUT BUTT HINGE	PROJECT OUT
LOCKING HARDWARE	F MPL W/ STANDARD 4" HANDLE			STANDARD	STANDARD	STANDARD
	F MPL W/ EXTENDED 8" HANDLE			OPTIONAL	OPTIONAL	OPTIONAL
	V MPL W/ EXTENDED HANDLE	STANDARD	STANDARD			
	LOCK BAR BASE	STANDARD	STANDARD	STANDARD	STANDARD	STANDARD
	LOCK BAR EXTENSION	STANDARD	STANDARD	STANDARD	STANDARD	STANDARD
	KEEPER	STANDARD	STANDARD	STANDARD	STANDARD	STANDARD
HINGE & LIMIT STOP HARDWARE	SINGLE ARM OPERATOR			STANDARD	STANDARD	
	DUAL ARM OPERATOR					STANDARD
	LARGE HANDLE CRANK			STANDARD	STANDARD	STANDARD
	LOOSE RIVET 4-BAR HINGE					STANDARD
	12" 4-BAR HINGE	STANDARD		STANDARD		
	BUTT HINGE		STANDARD		STANDARD	
	NYC FALL PREVENTION LIMIT DEVICE *	OPTIONAL	OPTIONAL		OPTIONAL	OPTIONAL
	GUIDE ROLLER	STANDARD		STANDARD		
SCREENS	OPTIONAL	OPTIONAL	OPTIONAL	OPTIONAL	OPTIONAL	

* Refer to Tech Drawings for more information.