

TABLE OF CONTENTS

**YOW 225 OPERABLE WINDOWS
2-1/4" DEPTH**

WINDOW VARIATIONS	Page 2
YOW 225 STANDARD WINDOW CONFIGURATIONS	Pages 3 & 4
YOW 225 FIXED WINDOW DETAILS (1/2 SIZE).....	Page 5
YOW 225 CASEMENT OUTSWING/INSWING DETAILS (1/2 SIZE)	Pages 6 to 15
YOW 225 PROJECT OUT/IN DETAILS (1/2 SIZE).....	Pages 16 to 22
YOW 225 INSULATING GLAZING DETAILS (1/2 SIZE).....	Page 23
YOW 225 ACCESSIBLE WINDOW HARDWARE OPTIONS (1/2 SIZE).....	Page 24 to 27
YOW 225 ACCESSIBLE WINDOW SCREEN OPTIONS (1/2 SIZE)	Page 28 to 30
YOW 225 ANCHORING OPTIONS	Pages 31 & 32
YOW 225 SILL FLASHING & EXTERIOR TRIM DETAILS	Pages 33 & 34
YOW 225 MULLION OPTIONS & DETAILS.....	Pages 35 to 36
YOW 225 MULLION DESIGN PRESSURES	Pages 38 to 40
YOW 225 SCREEN OPTIONS & DETAILS	Pages 41 to 49
YOW 225 TECHNICAL NOTES	Pages 50 to 57
YOW 225 HARDWARE OPTIONS.....	Pages 58 & 59

*The latest installation instructions for this product are available at www.ykkap.com.

YOW 225 WINDOW VARIATIONS

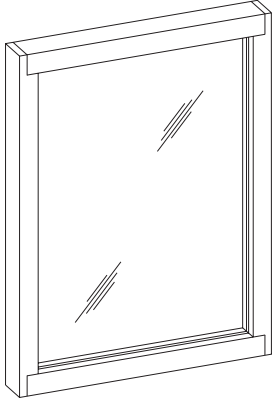

FIXED

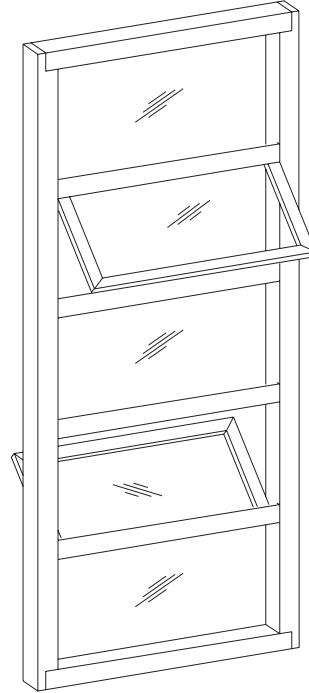

**PROJECT
IN/OUT SWING**

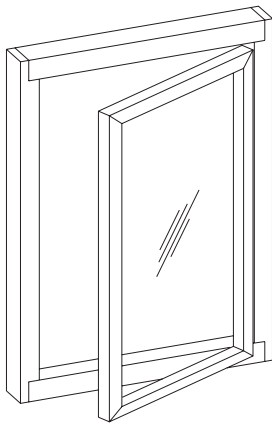

**CASEMENT
OUTSWING**

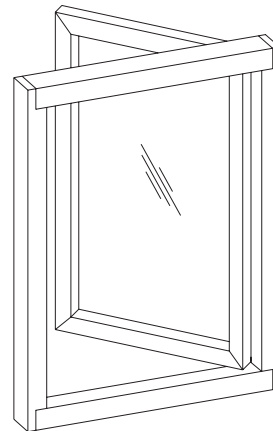

**CASEMENT
INSWING**

FIXED

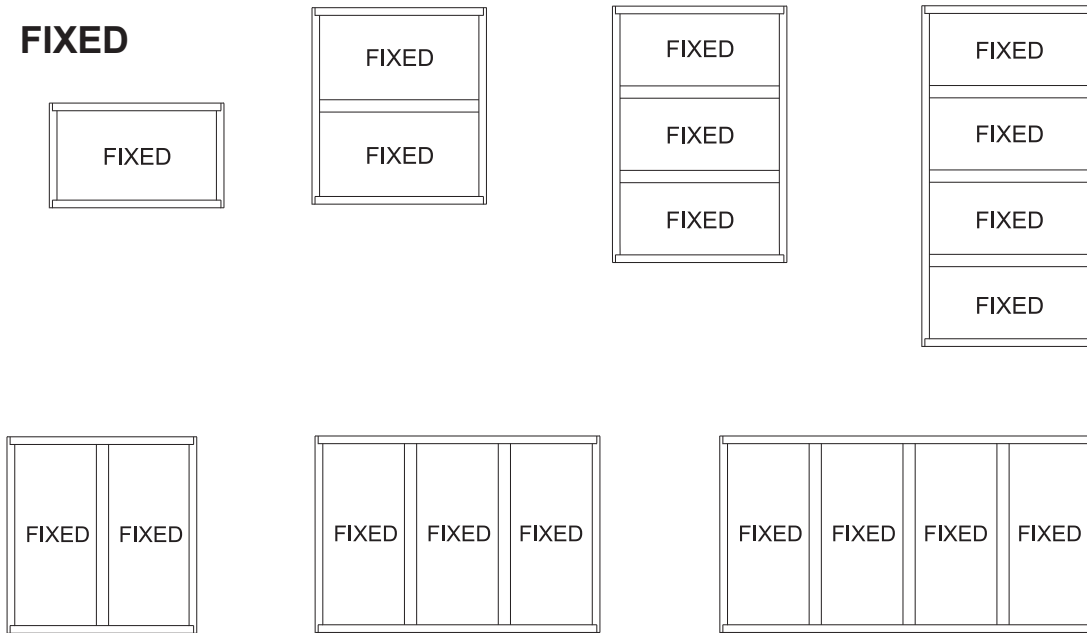

CASEMENT OUTSWING

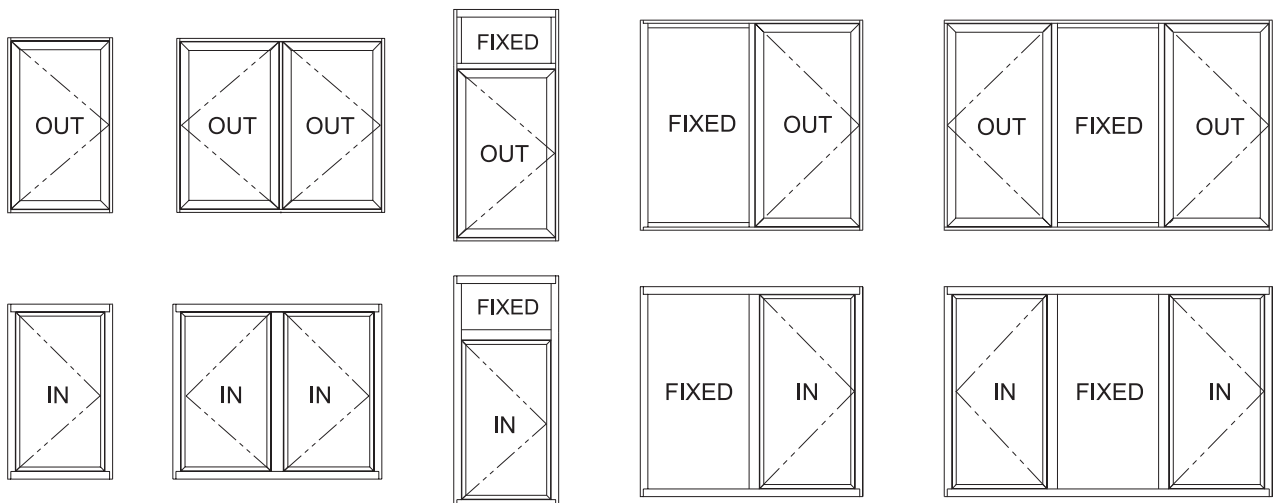

CASEMENT INSWING

PROJECT OUT

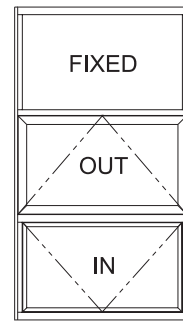
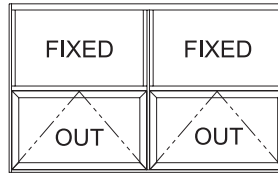
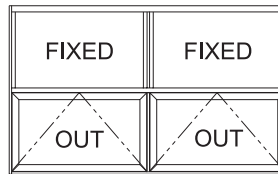
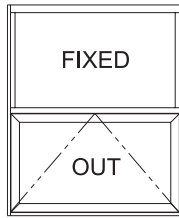
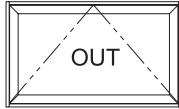

PROJECT IN

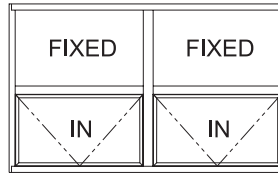
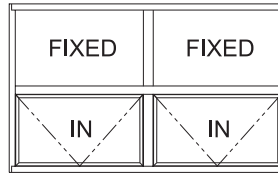
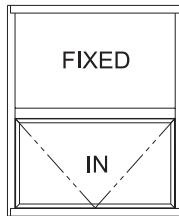
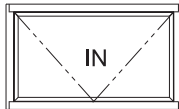

YOW 225 FIXED
1/4" Glazing (For 1" Glazing Option, See Page 23)

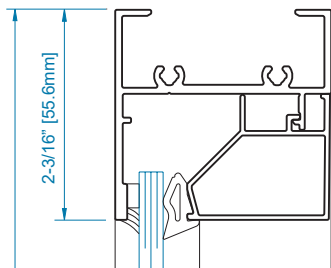
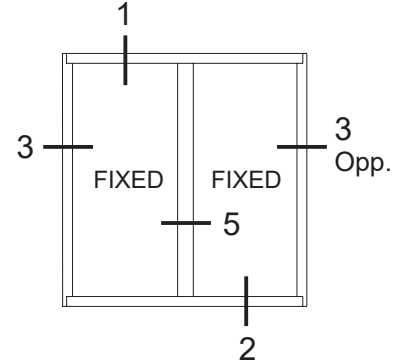
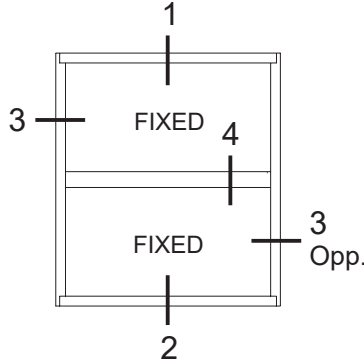
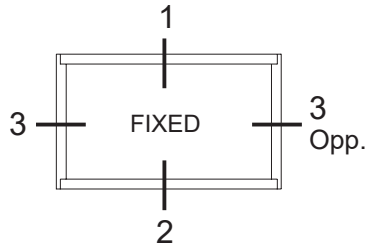

SECTION 1

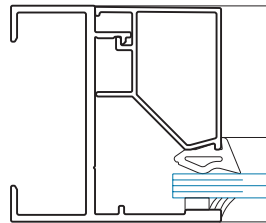

SECTION 3

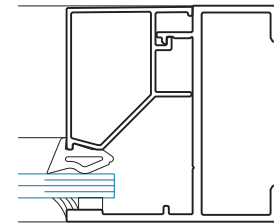

SECTION 3 Opp.

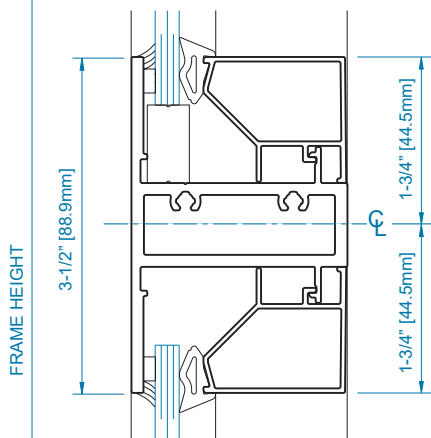

SECTION 4

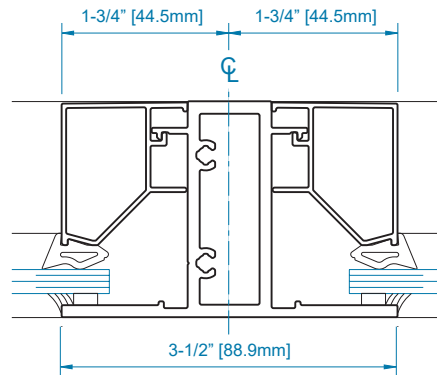

SECTION 5

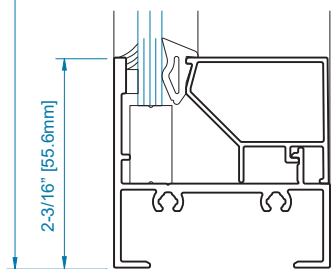

SECTION 2

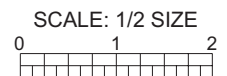

**YOW 225 CASEMENT OUTSWING
1/4" Glazing**

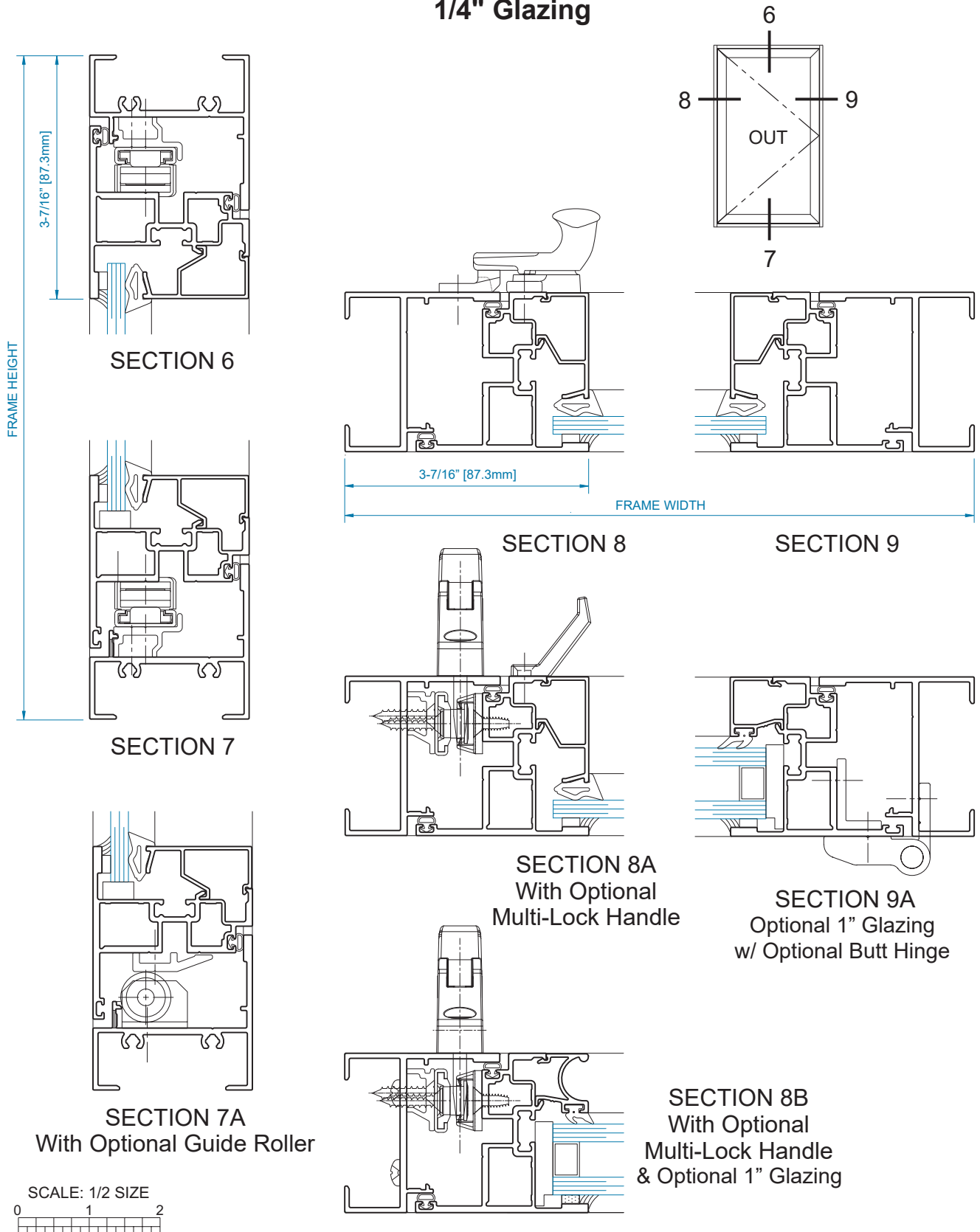

YOW 225 DOUBLE CASEMENT OUTSWING
1/4" Glazing

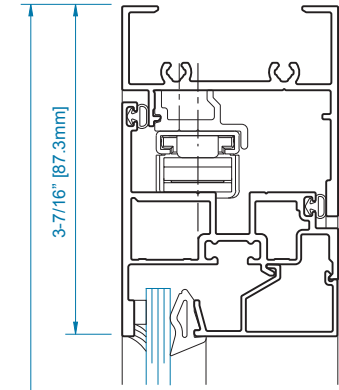

SECTION 6

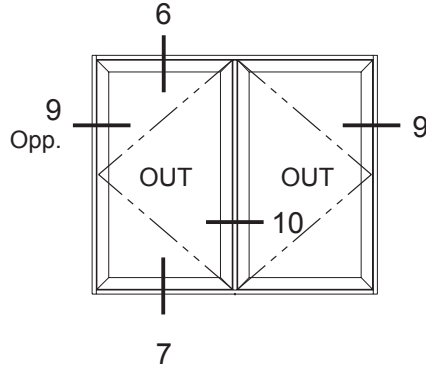

FRAME HEIGHT

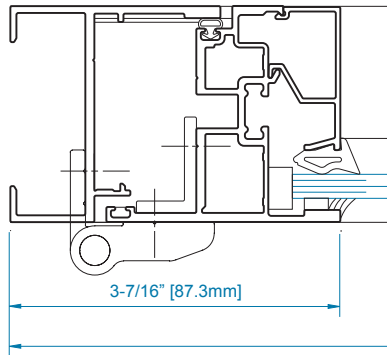

SECTION 9 Opp.
w/ Optional Butt Hinge

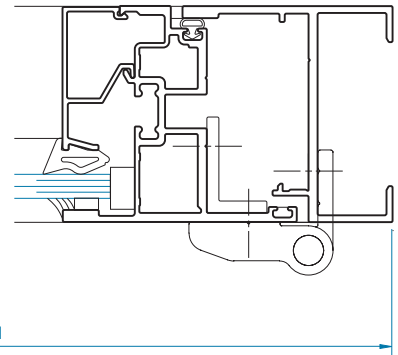

SECTION 9
w/ Optional Butt Hinge

FRAME WIDTH

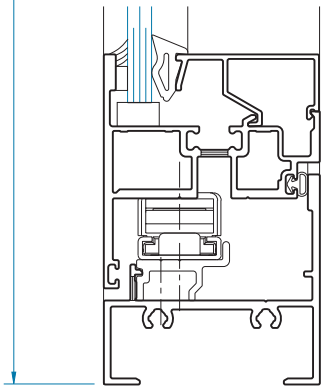

SECTION 7

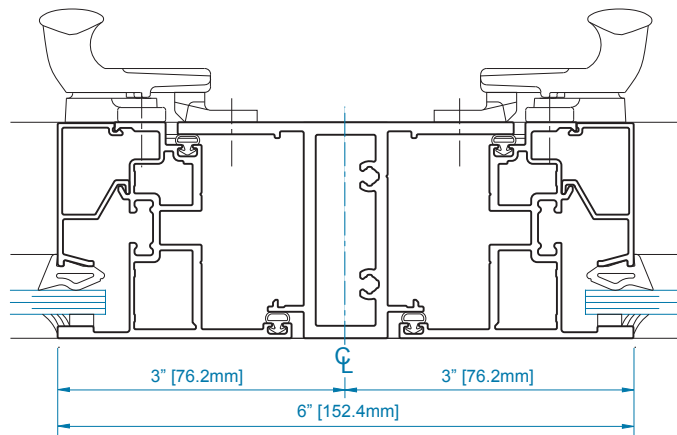

SECTION 10

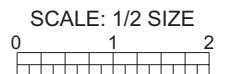

**YOW 225 FIXED/CASEMENT OUTSWING
1/4" Glazing**

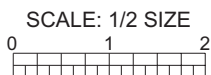
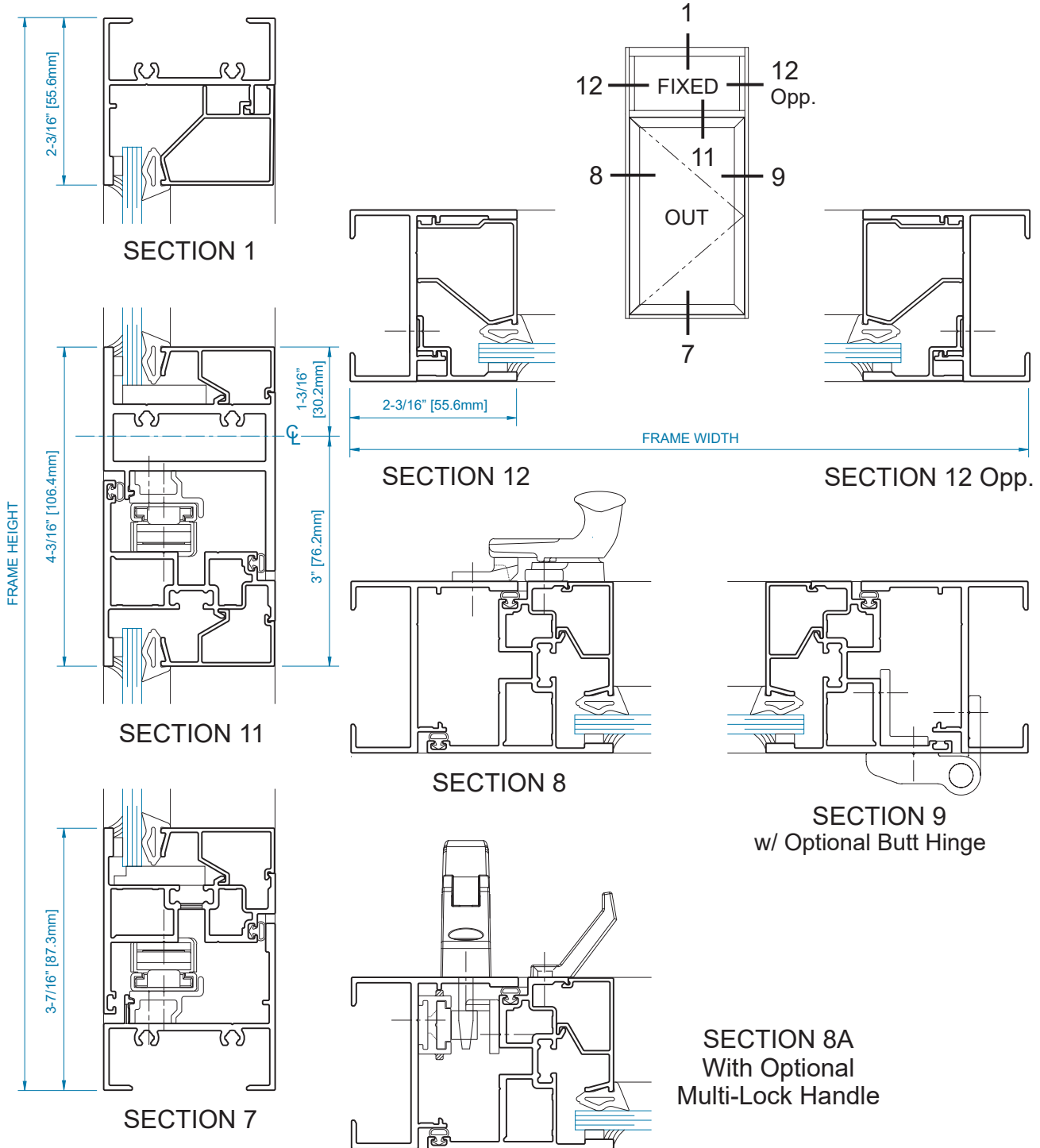

YOW 225 FIXED-CASEMENT OUTSWING
1/4" Glazing

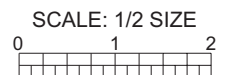
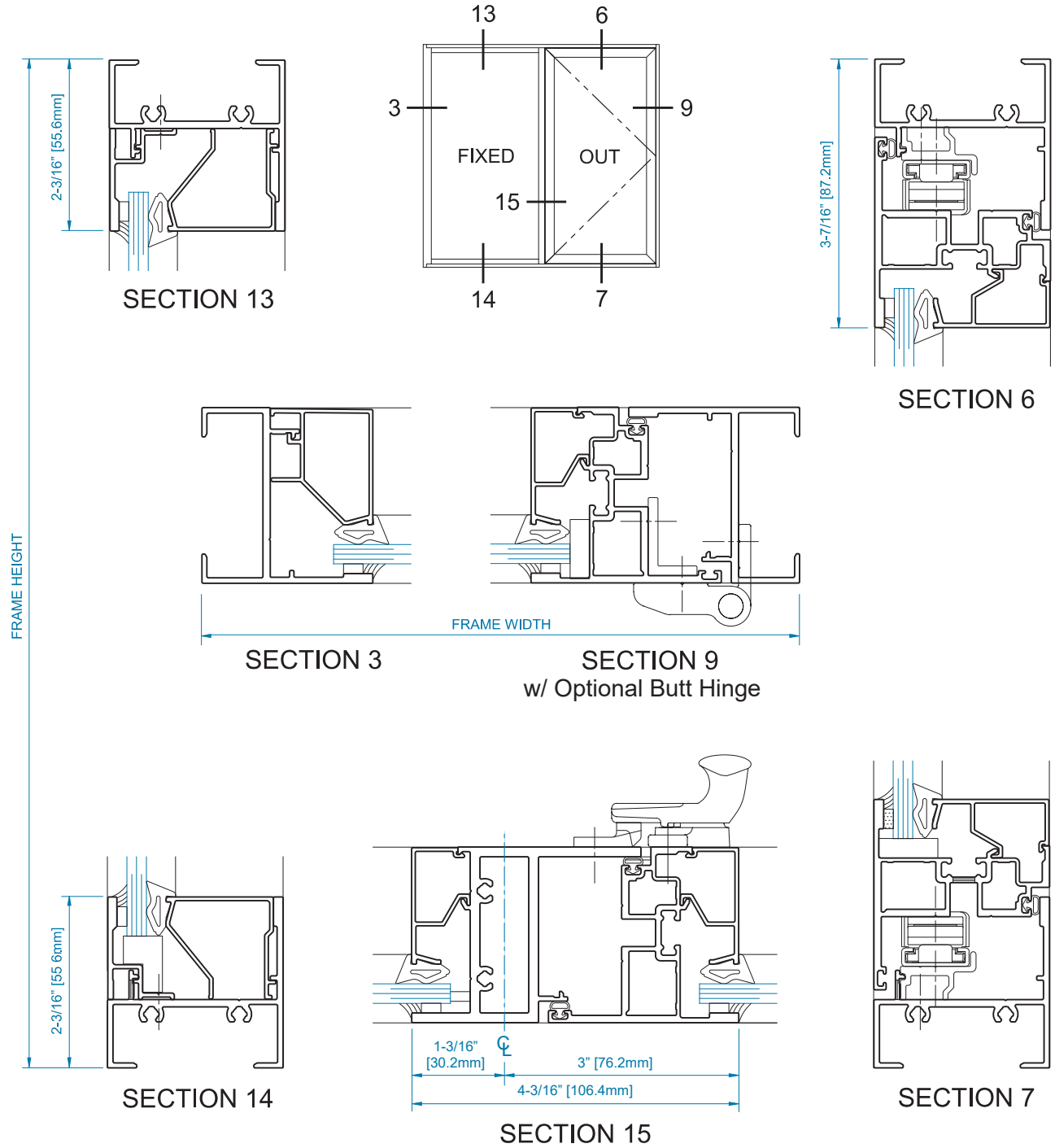

YOW 225 CASEMENT INSWING
1/4" Glazing

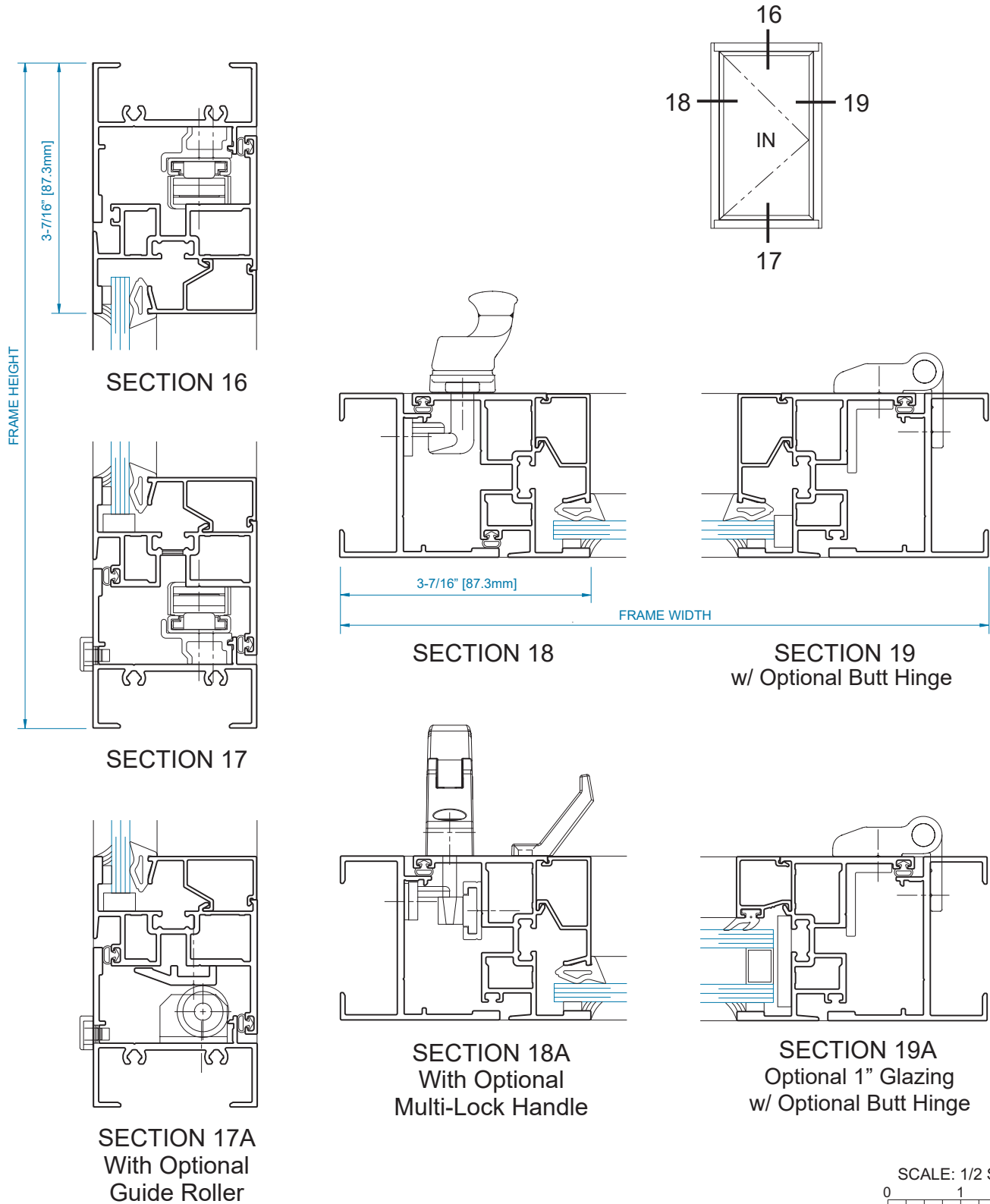

**YOW 225 DOUBLE CASEMENT INSWING
 1/4" Glazing**

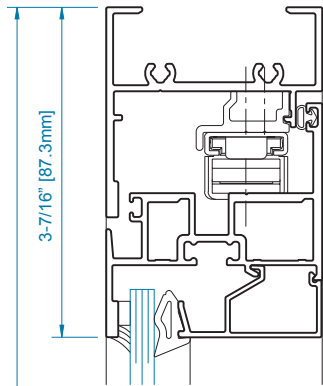

SECTION 16

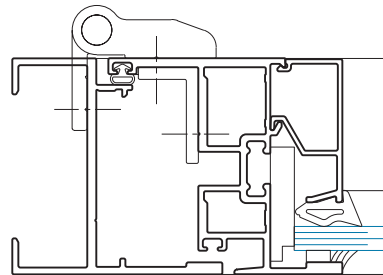
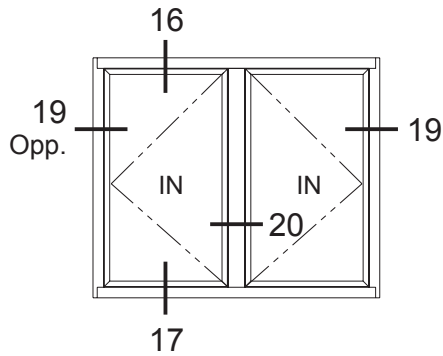

SECTION 19 Opp.
 w/ Optional Butt Hinge

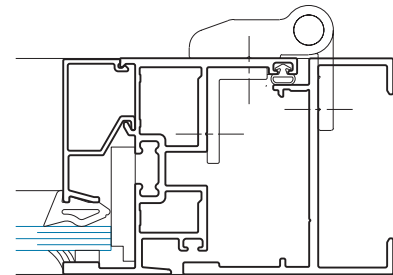

SECTION 19
 w/ Optional Butt Hinge

FRAME HEIGHT

3-7/16" [87.3mm]

FRAME WIDTH

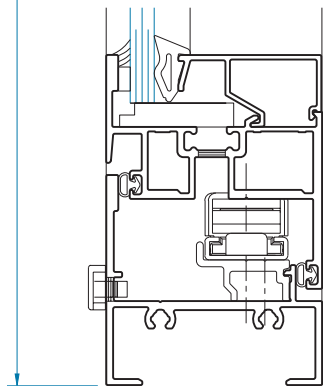

SECTION 17

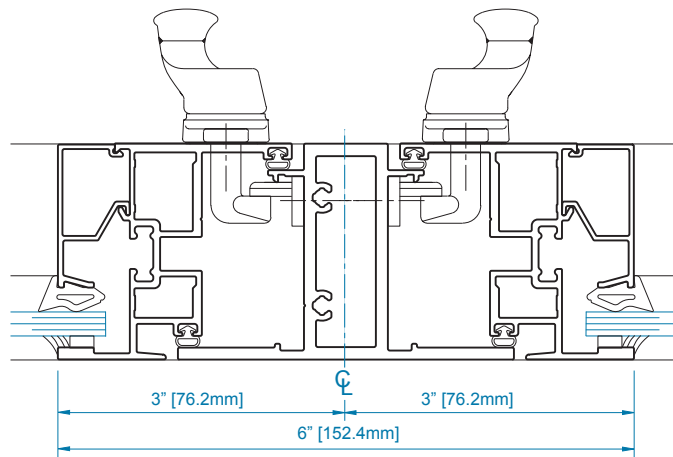

SECTION 20

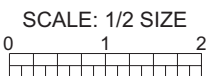

YOW 225 FIXED/CASEMENT INSWING
1/4" Glazing

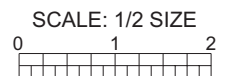
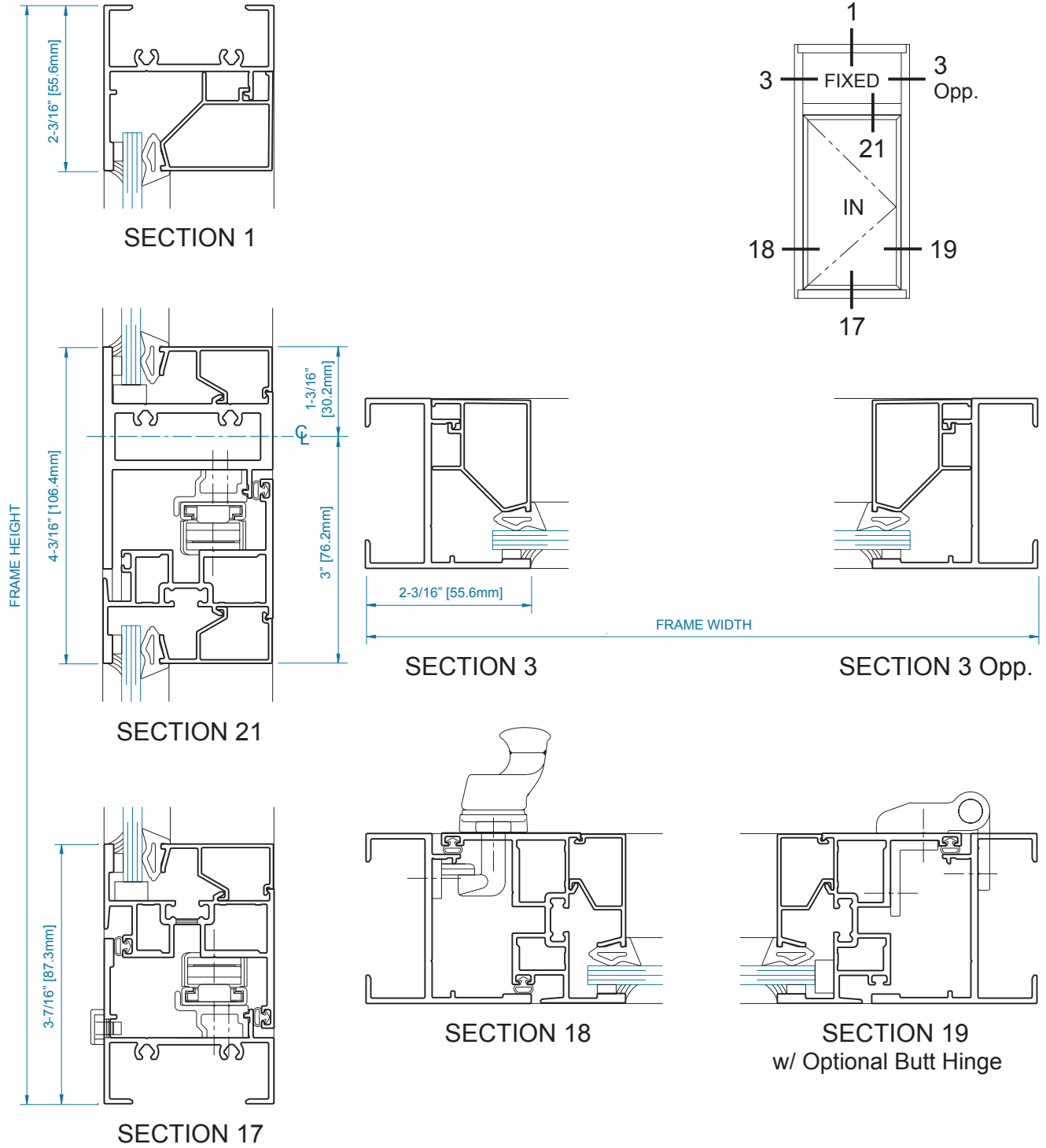

**YOW 225 FIXED-CASEMENT INSWING
1/4" Glazing**

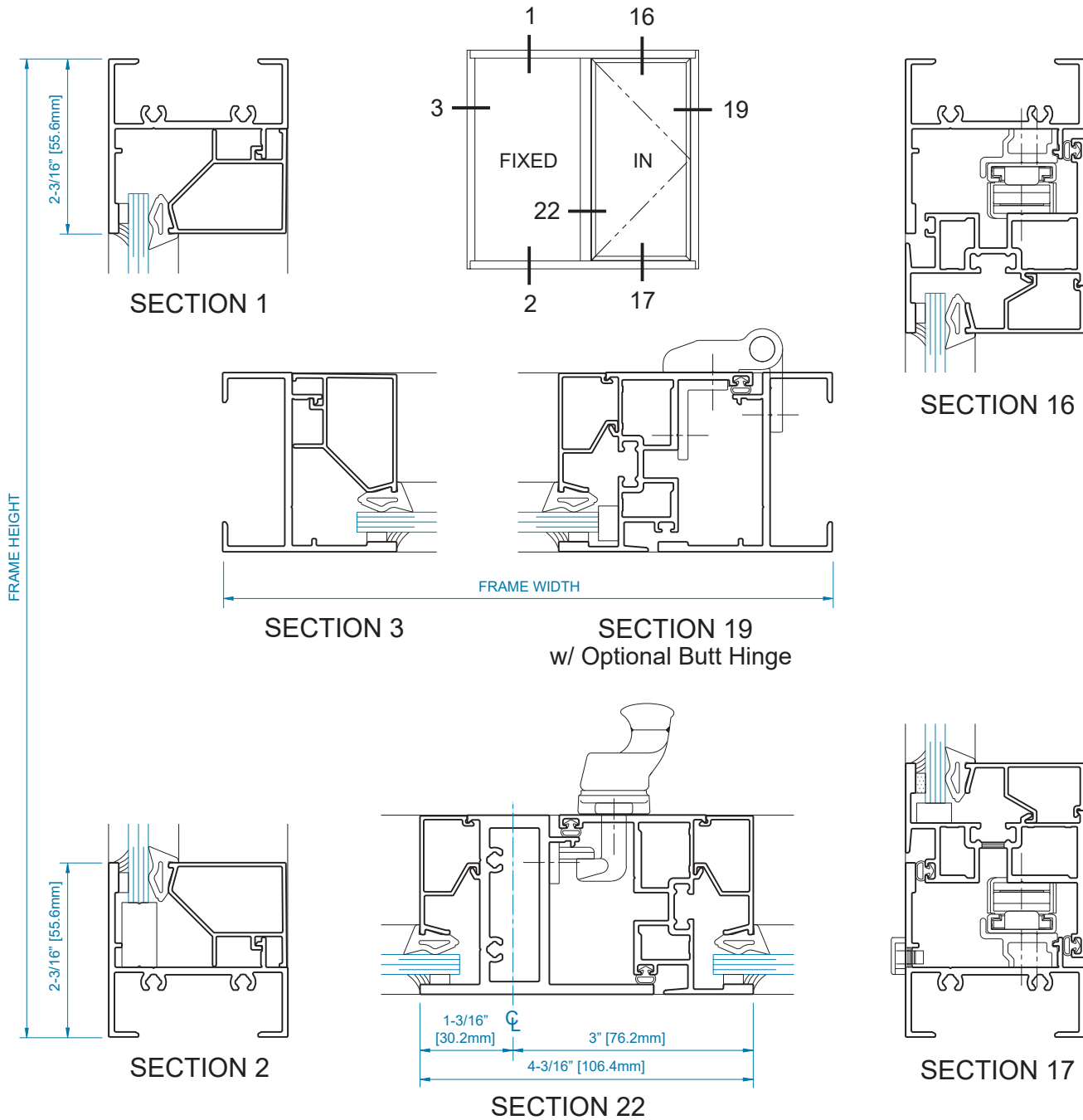

**YOW 225
CASEMENT INSWING-FIXED-CASEMENT INSWING
1/4" Glazing**

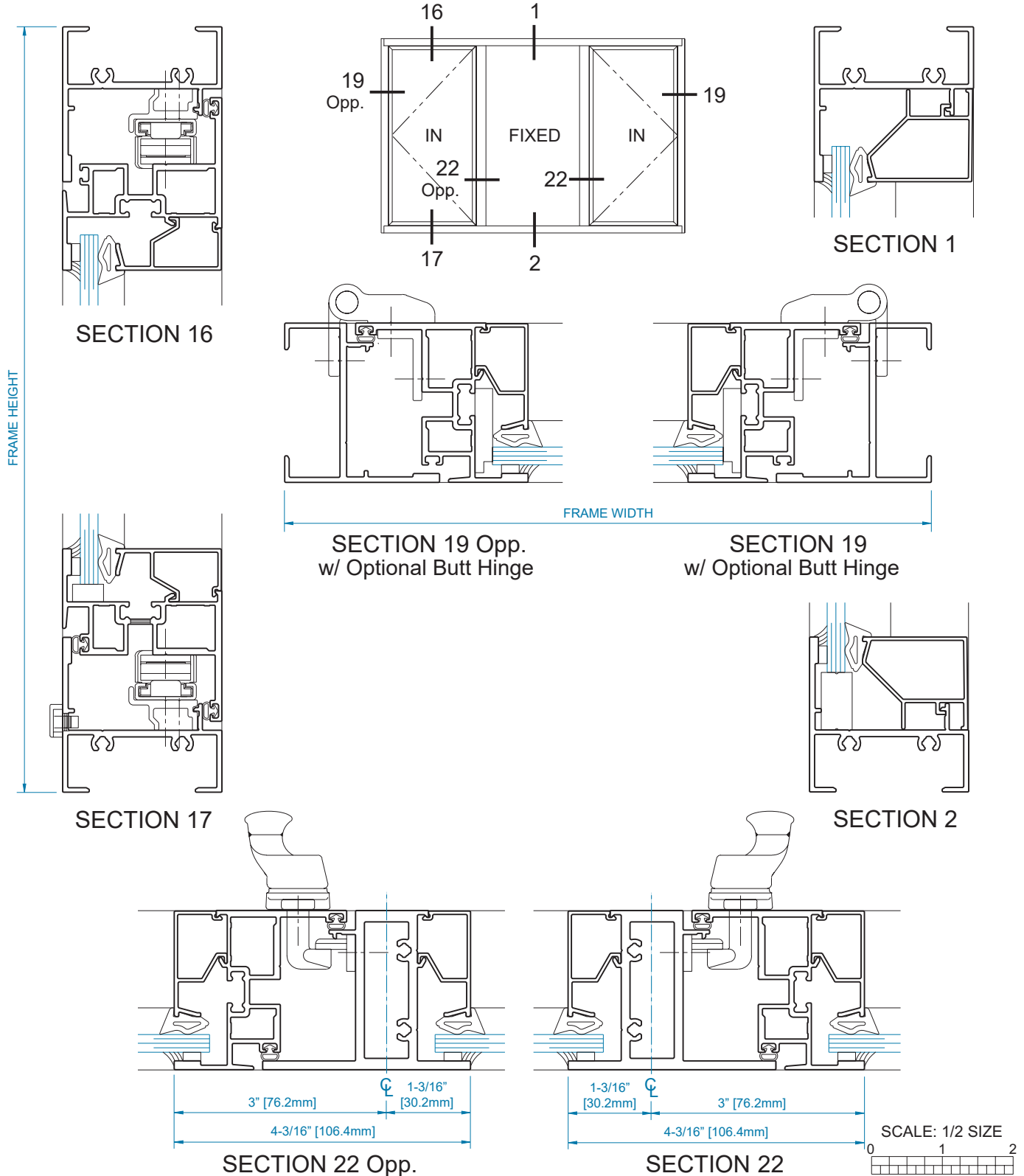

YOW 225 PROJECT OUT
1/4" Glazing

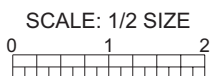
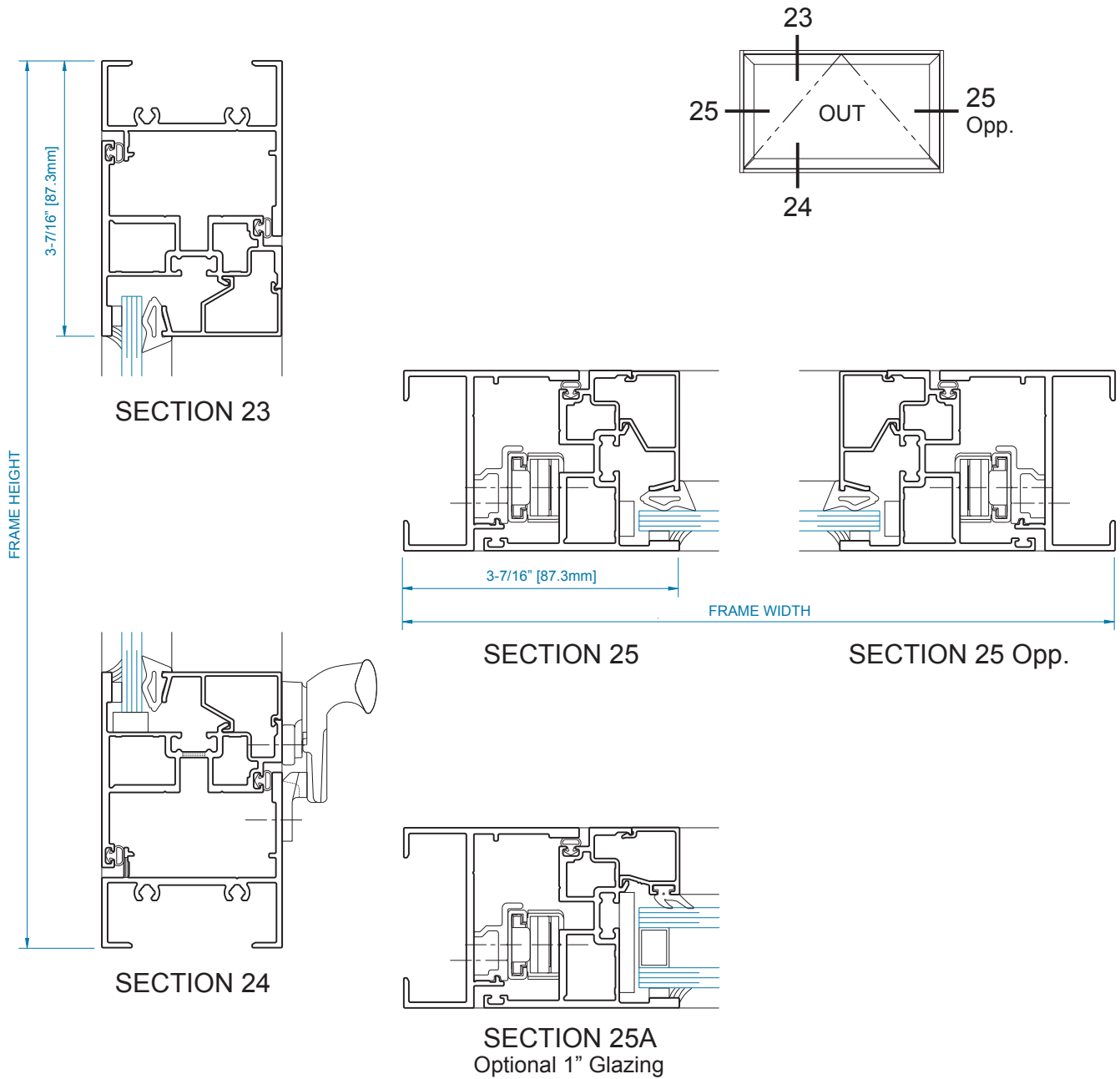

YOW 225 FIXED/PROJECT OUT
1/4" Glazing

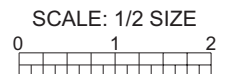
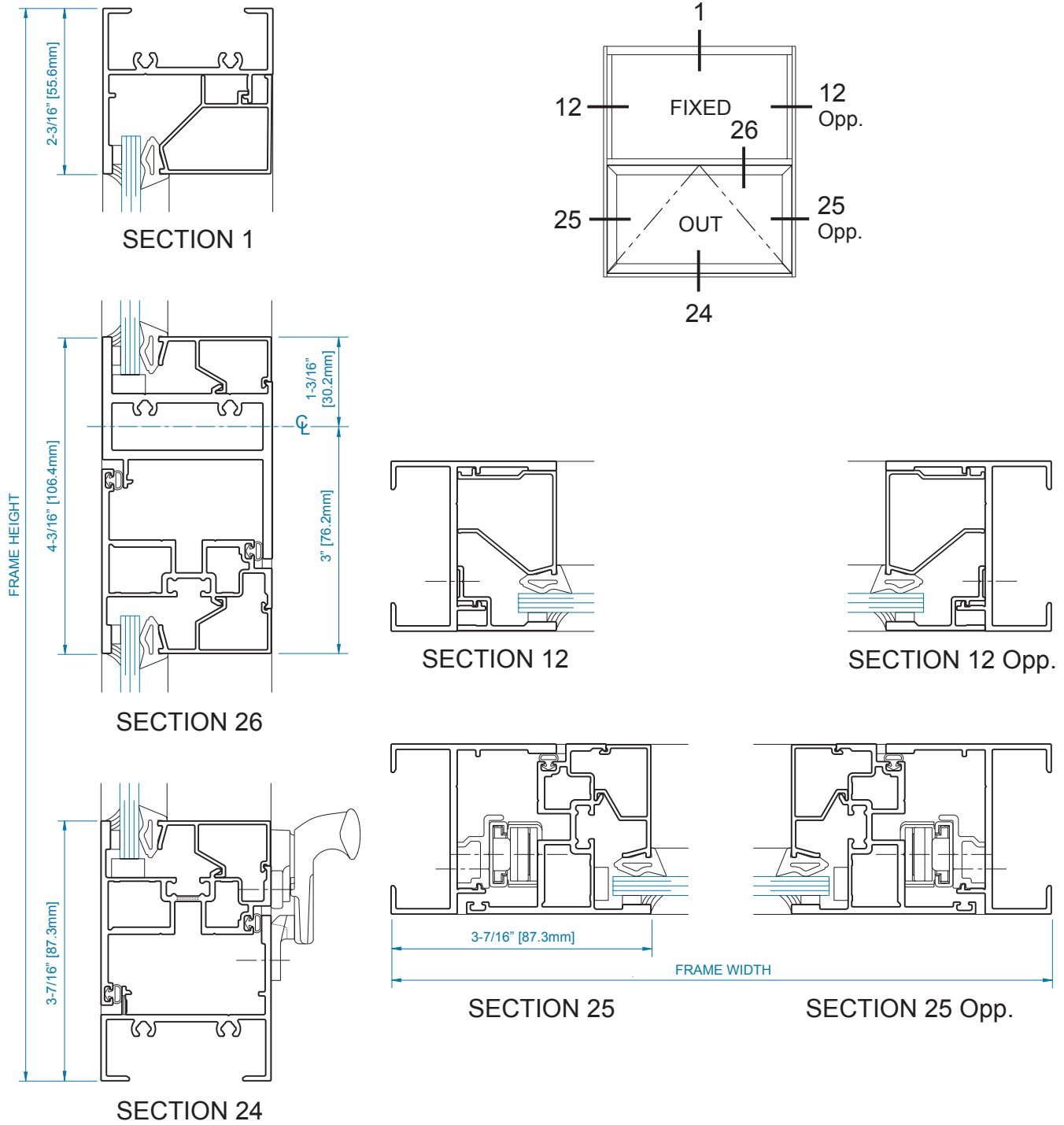

YOW 225 DOUBLE FIXED/PROJECT OUT
1/4" Glazing

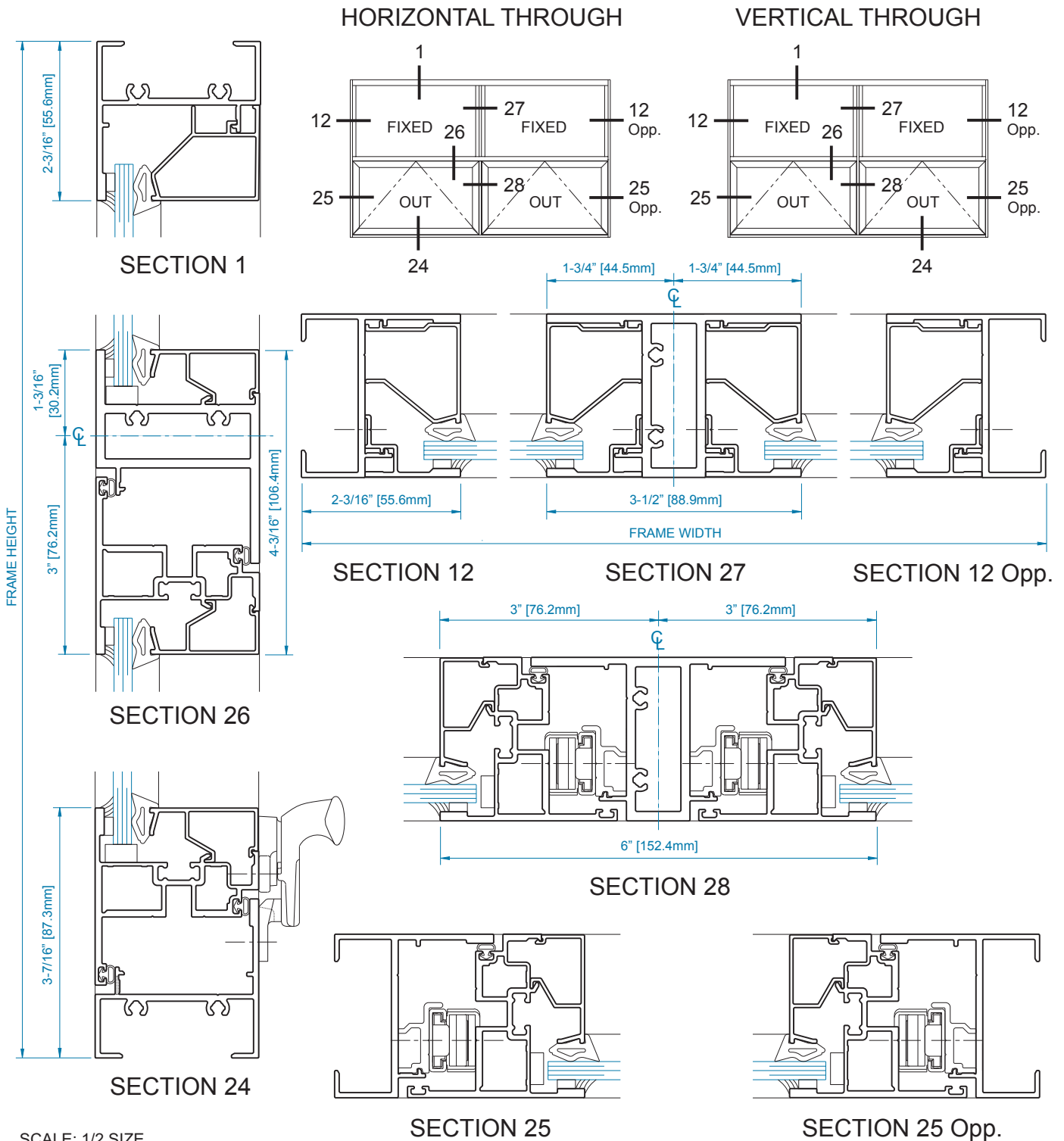

**YOW 225 PROJECT IN
1/4" Glazing**

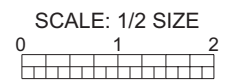
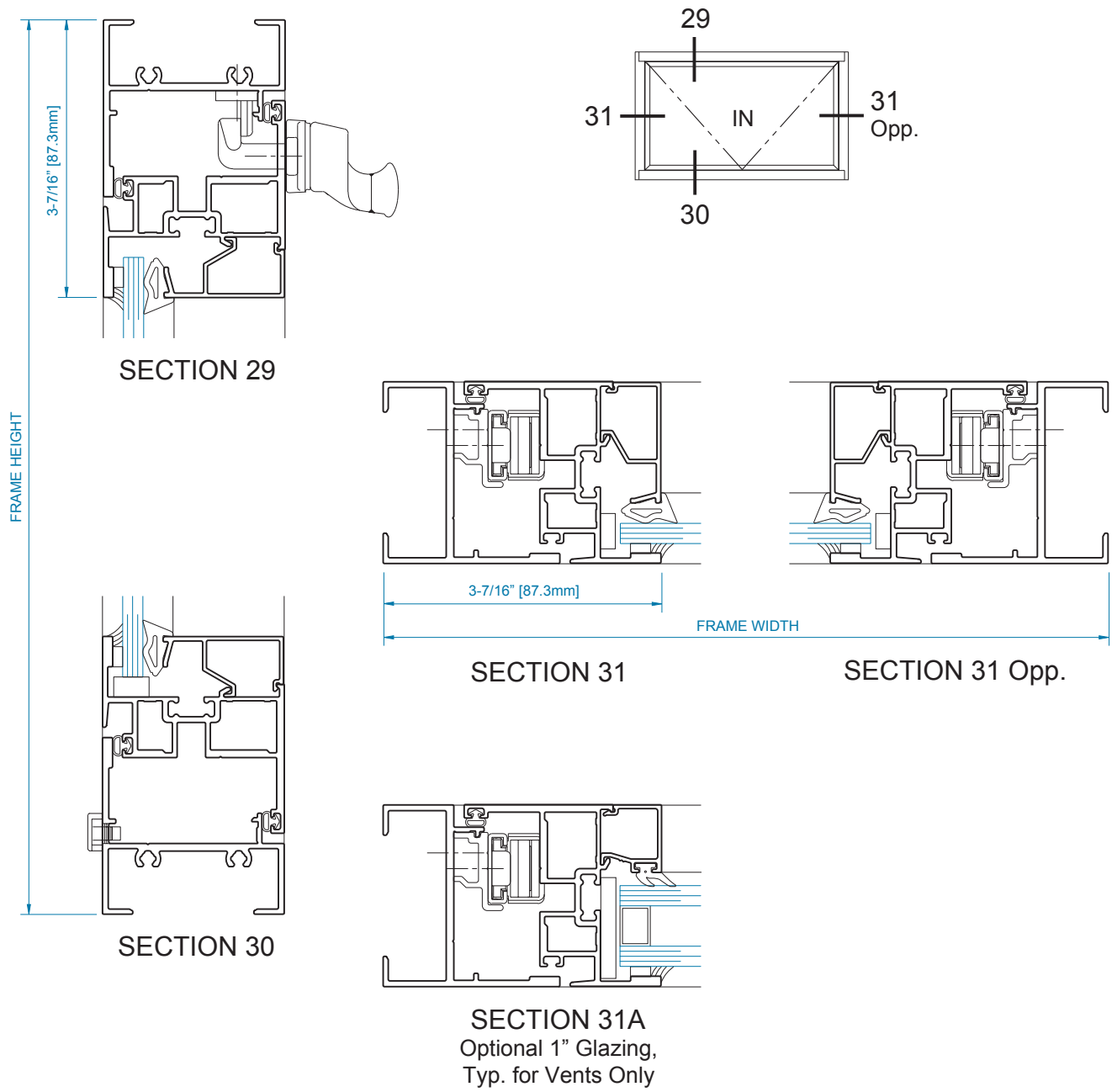

YOW 225 FIXED/PROJECT IN
1/4" Glazing

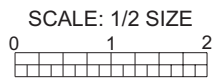
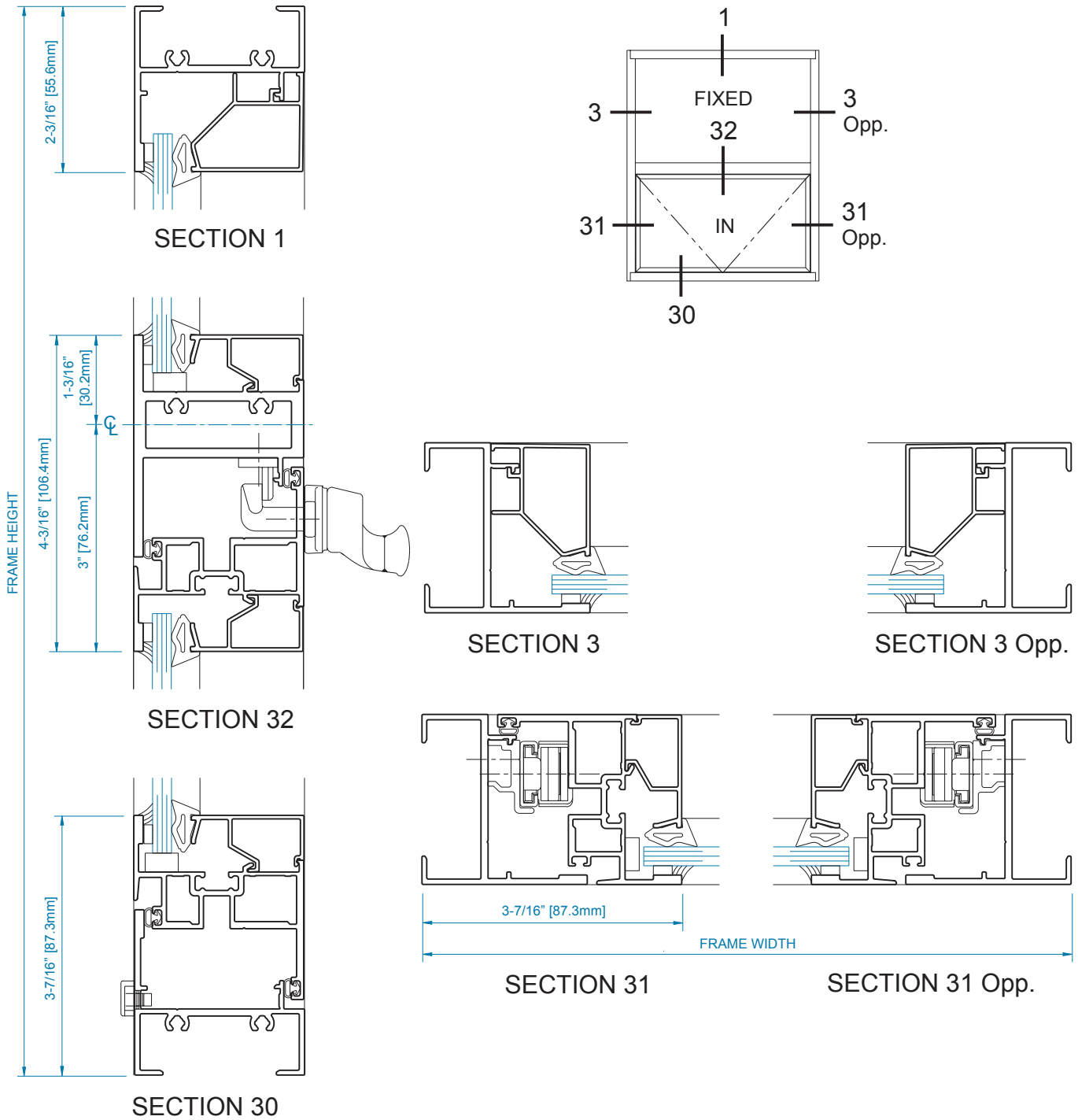

**YOW 225 DOUBLE FIXED/PROJECT IN
1/4" Glazing**

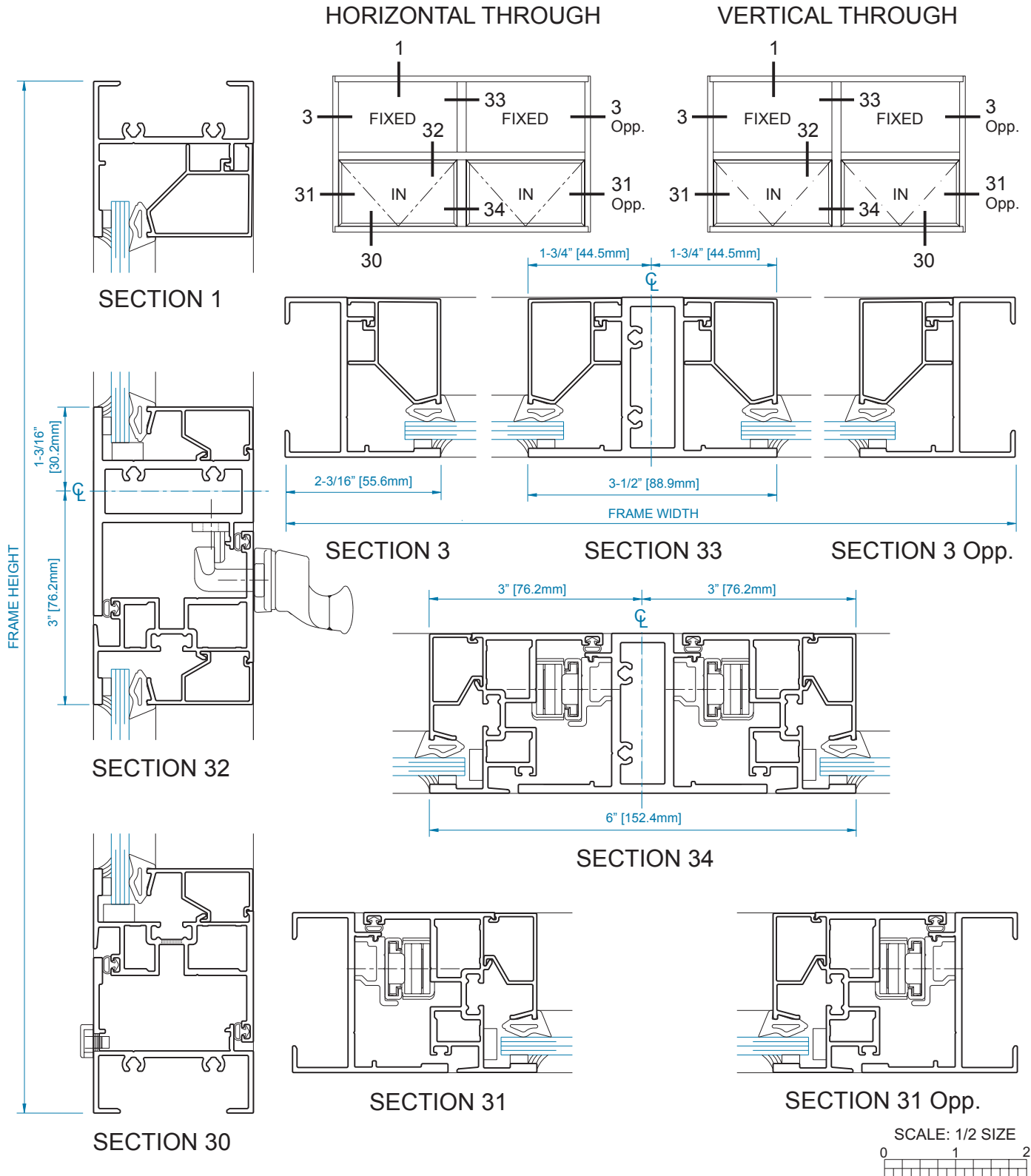

YOW 225 FIXED/PROJECT OUT/PROJECT IN
1/4" Glazing

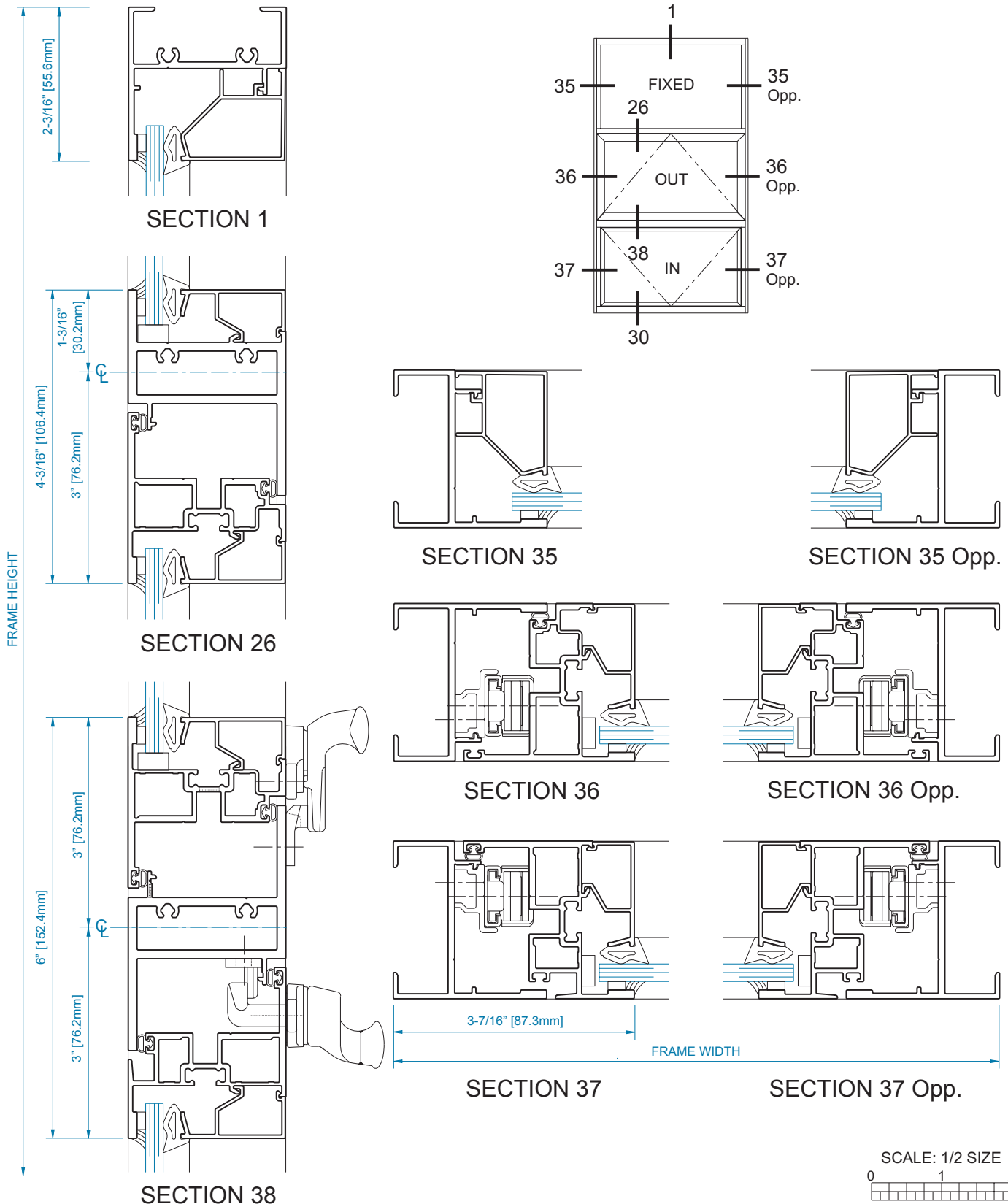

YOW 225 INSULATING OPTION
1" Glazing

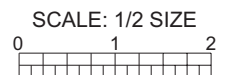
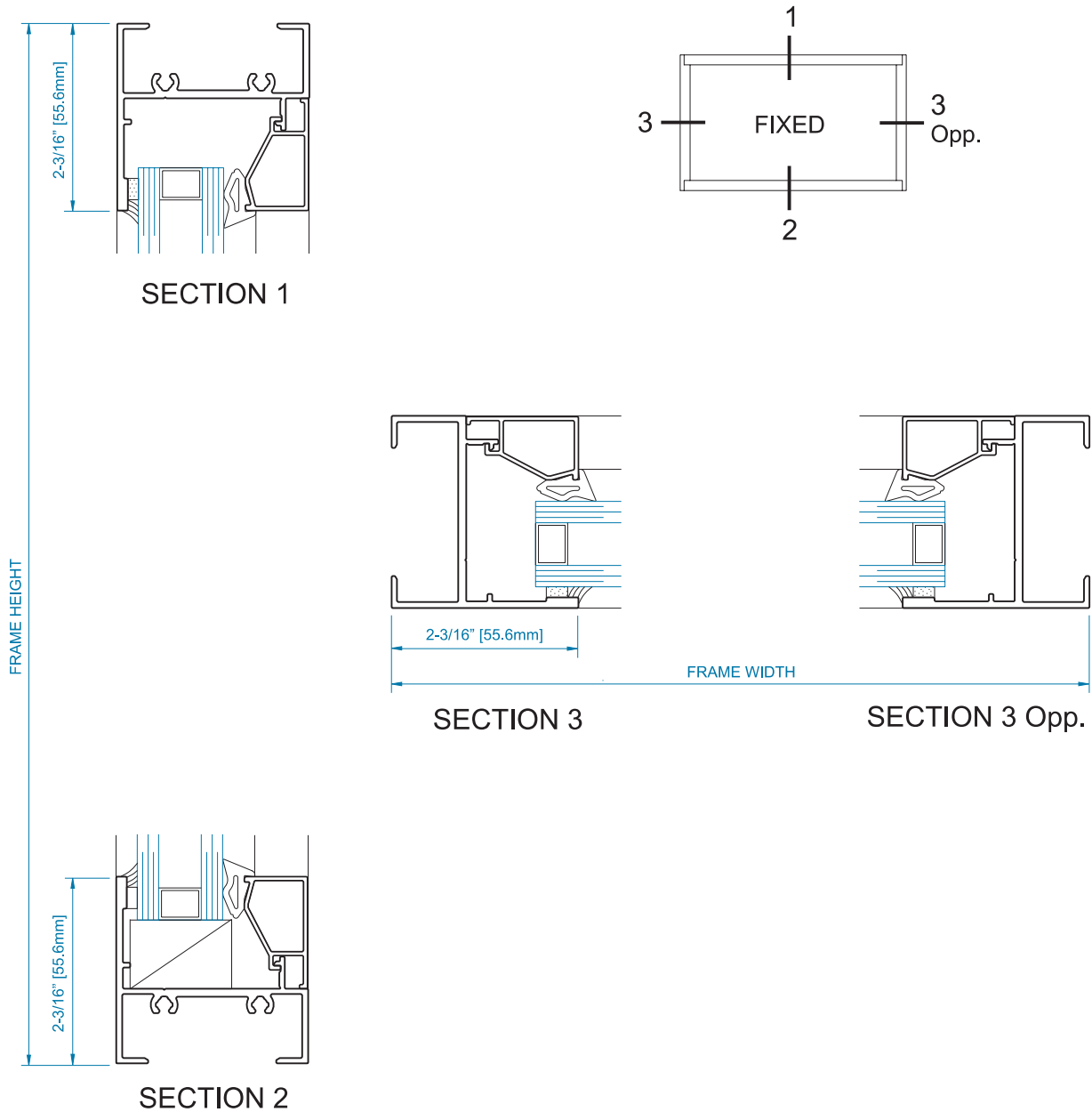

ACCESSIBLE WINDOW HARDWARE OPTIONS FOR CASEMENT OUTSWING (4-BAR HINGES)

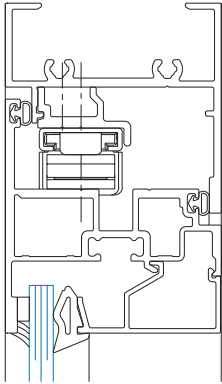

SECTION 1

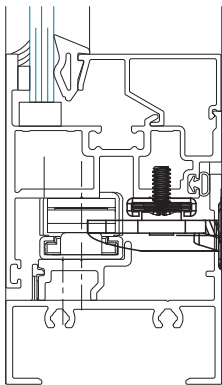
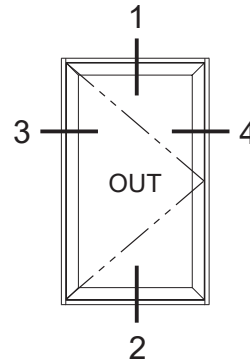

SECTION 2
w/ 4-Bar Hinge

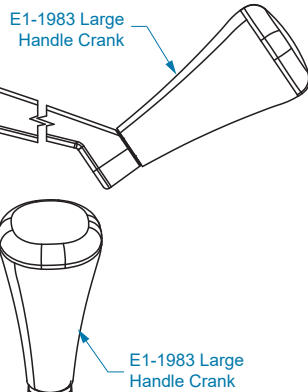

E1-1983 Large Handle Crank

E1-1983 Large Handle Crank

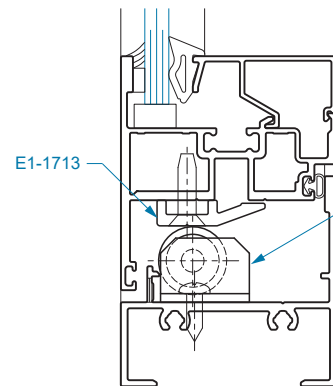

SECTION 2A
At Roller Guide

E1-1713

K-10639

E1-1987, E1-1988,
E1-1989, or E1-1990
Single Arm Operator

E1-1966 Standard
4" Multilock Handle,
E1-1994 Optional
8" Multilock Handle

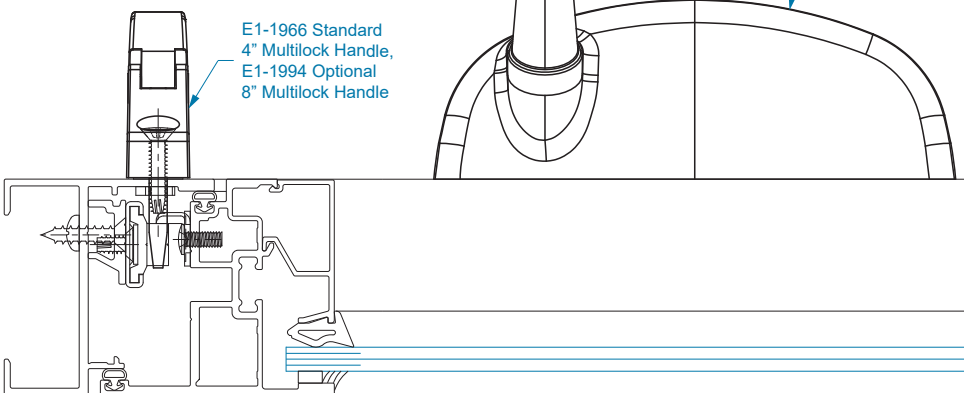

SECTION 3
w/ 4-Bar Hinge

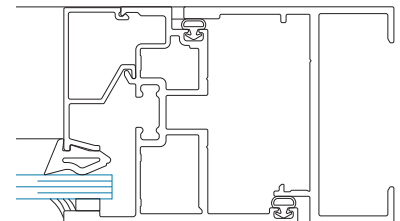

SECTION 4
w/ 4-Bar Hinge

**ACCESSIBLE WINDOW HARDWARE OPTIONS FOR
CASEMENT OUTSWING (BUTT HINGES)**

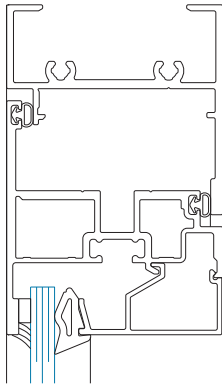

SECTION 1

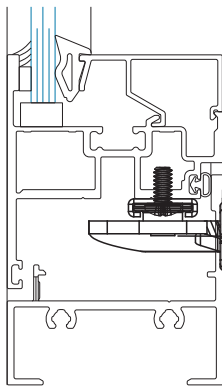
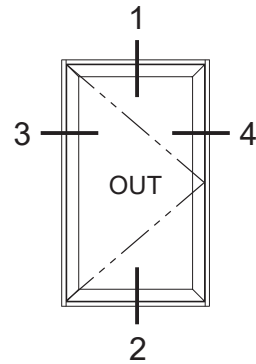

SECTION 2
w/ Butt Hinge

E1-1983 Large
Handle Crank

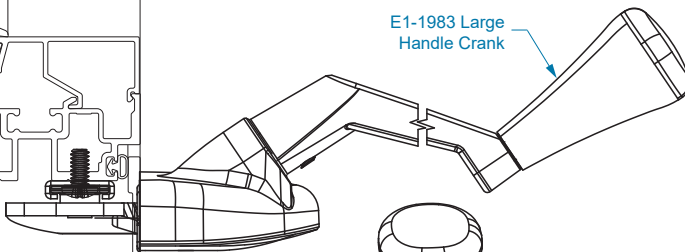

E1-1983 Large
Handle Crank

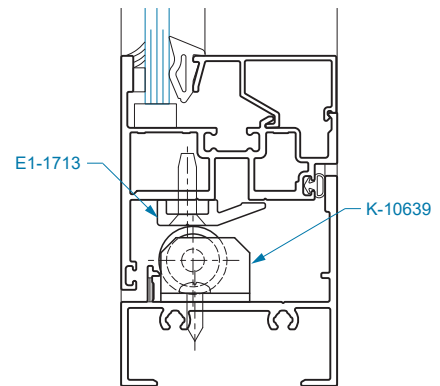

SECTION 2A
At Roller Guide

E1-1987, E1-1988,
E1-1989, or E1-1990
Single Arm Operator

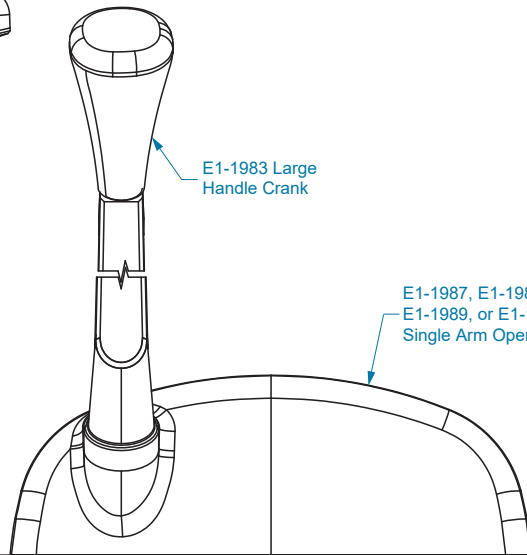

E1-1966 Standard
4" Multilock Handle,
E1-1994 Optional
8" Multilock Handle

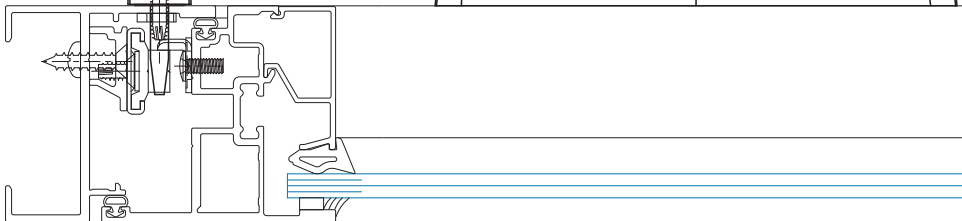
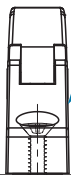

SECTION 3
w/ Butt Hinge

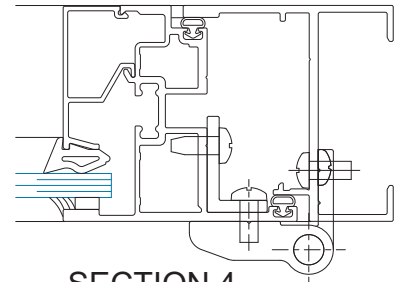

SECTION 4
w/ Butt Hinge

**ACCESSIBLE WINDOW HARDWARE OPTIONS FOR
CASEMENT INSWING**

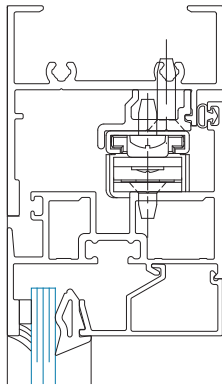

SECTION 1
Head w/
4-Bar Hinge

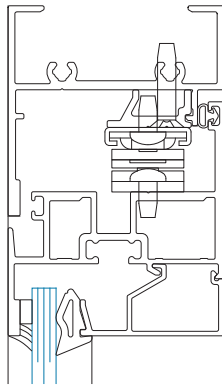

SECTION 1A
Head w/
Butt Hinge

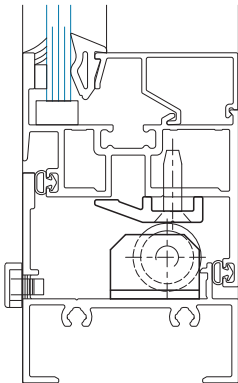
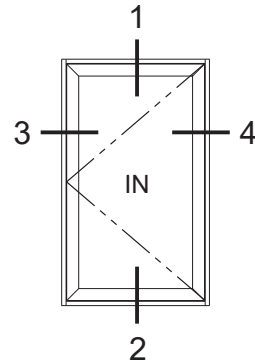

SECTION 2
Sill for 4-Bar
& Butt Hinges

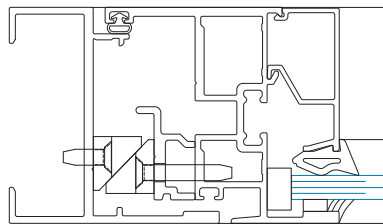

SECTION 3
w/ 4-Bar Hinge

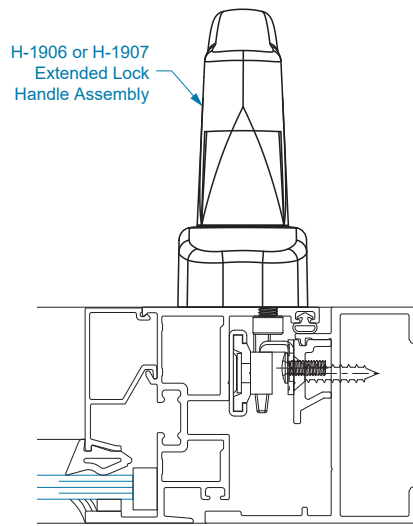

SECTION 4

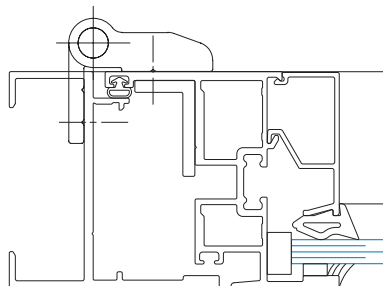

SECTION 3A
w/ Butt Hinge

ACCESSIBLE WINDOW HARDWARE OPTIONS FOR PROJECT OUT

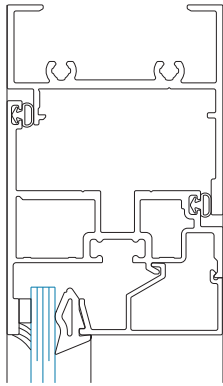

SECTION 1

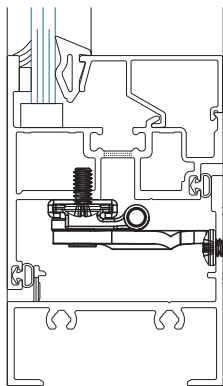
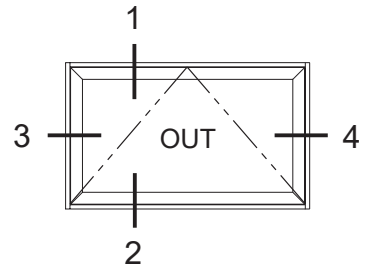

SECTION 2
w/ 4-Bar Hinge

E1-1983 Large Handle Crank

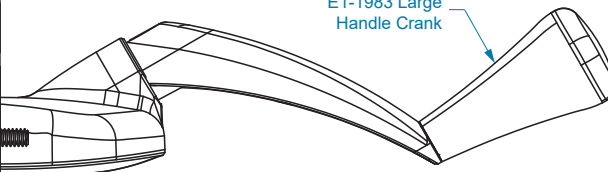

E1-1983 Large Handle Crank

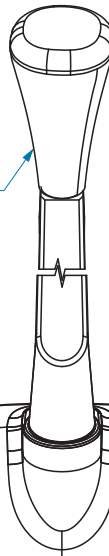

E1-1992 Dual Arm Operator

E1-1966 Standard 4" Multilock Handle,
E1-1994 Optional 8" Multilock Handle

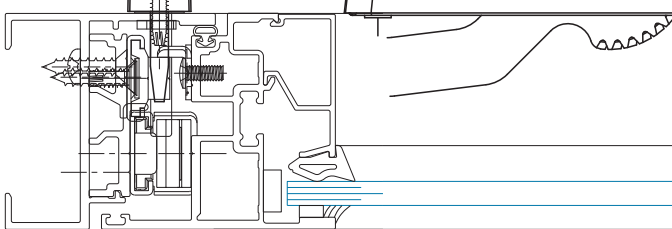
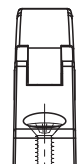
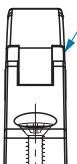

SECTION 3
w/ 4-Bar Hinge

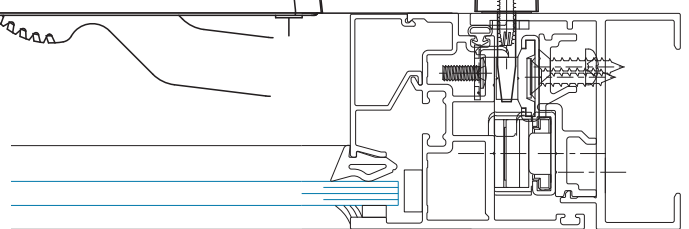

SECTION 4
w/ 4-Bar Hinge

ACCESSIBLE WINDOW SCREEN OPTIONS FOR CASEMENT OUTSWING

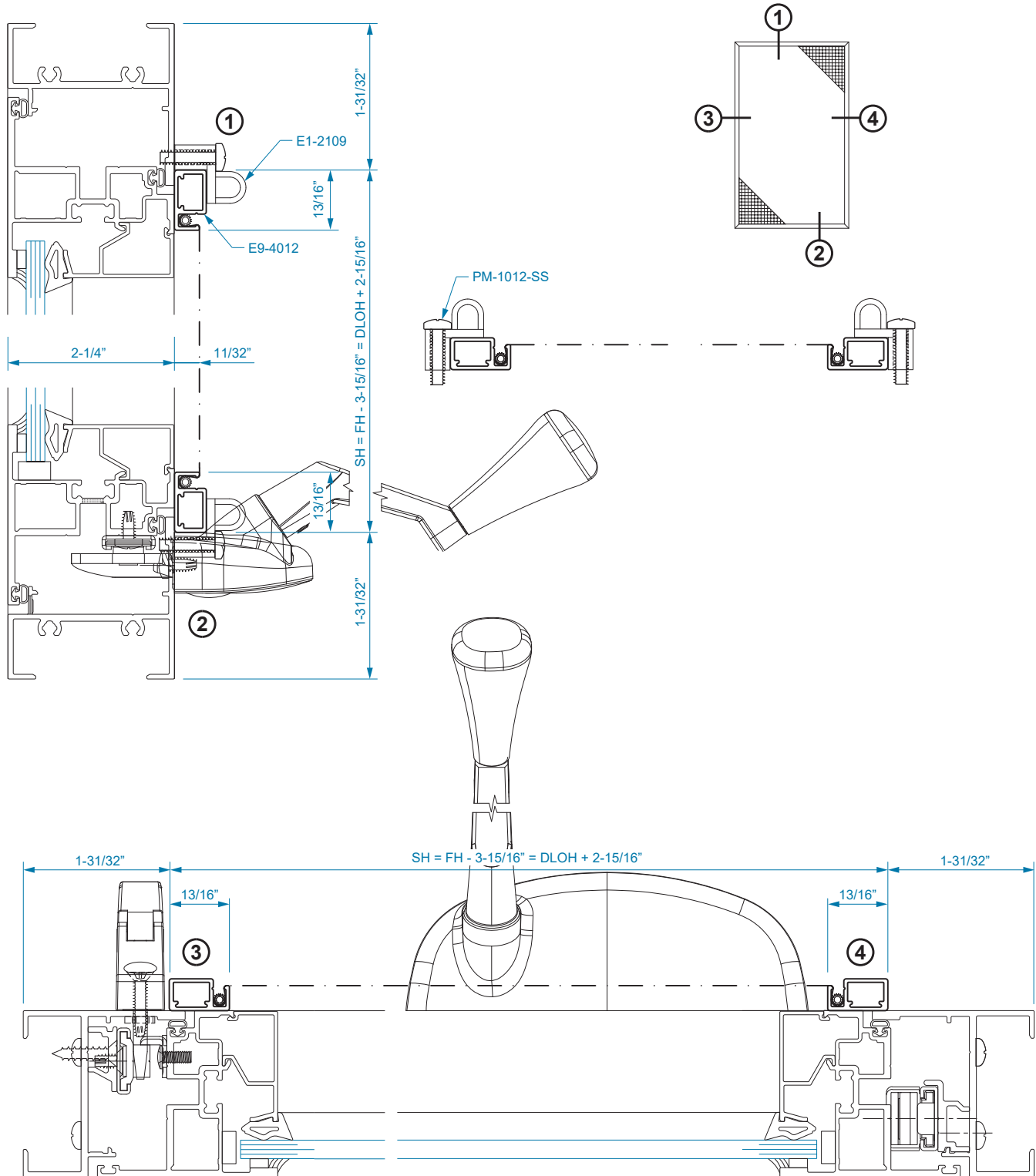

ACCESSIBLE WINDOW SCREEN OPTIONS FOR CASEMENT INSWING

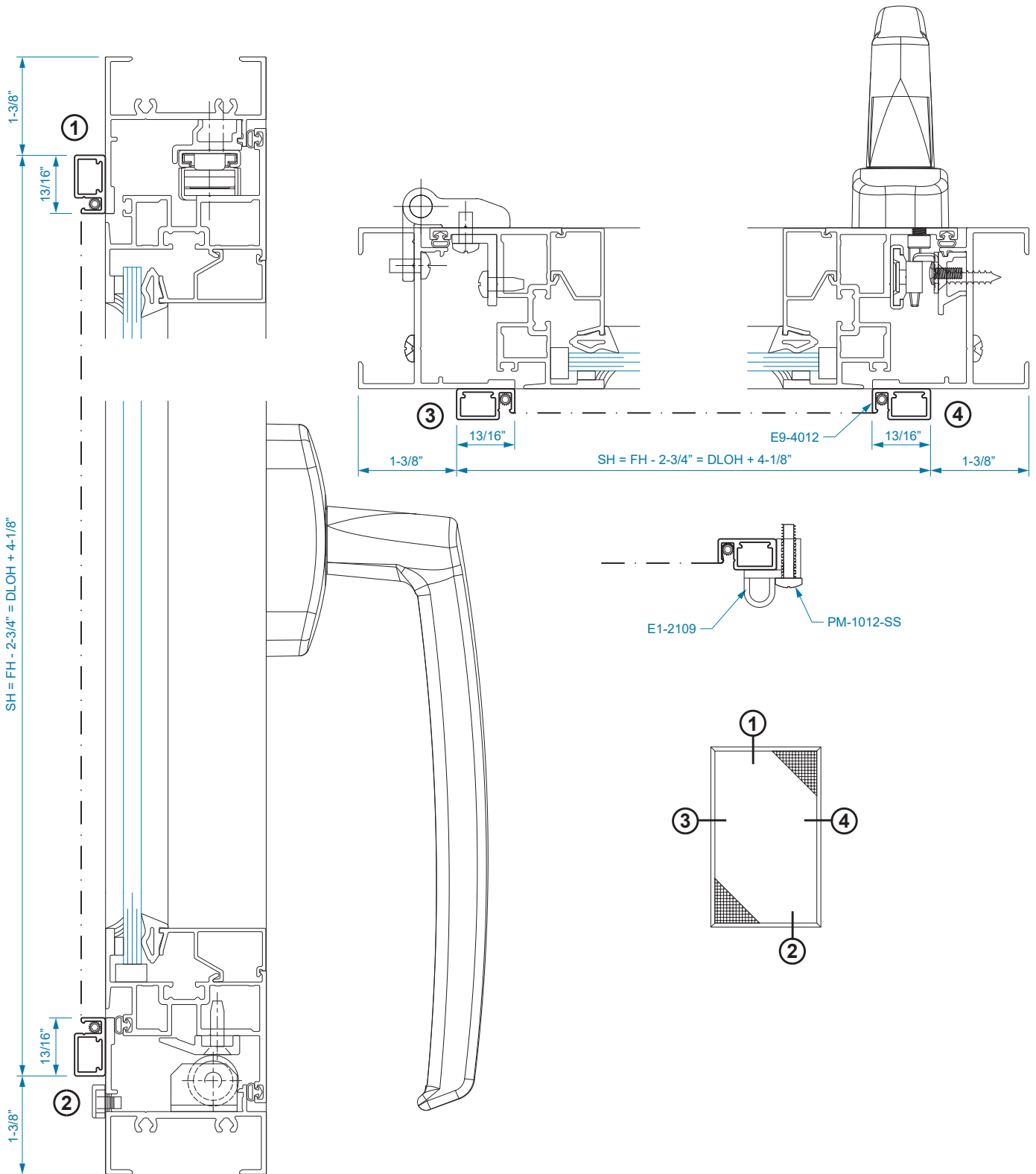

ACCESSIBLE WINDOW SCREEN OPTIONS FOR PROJECT OUT

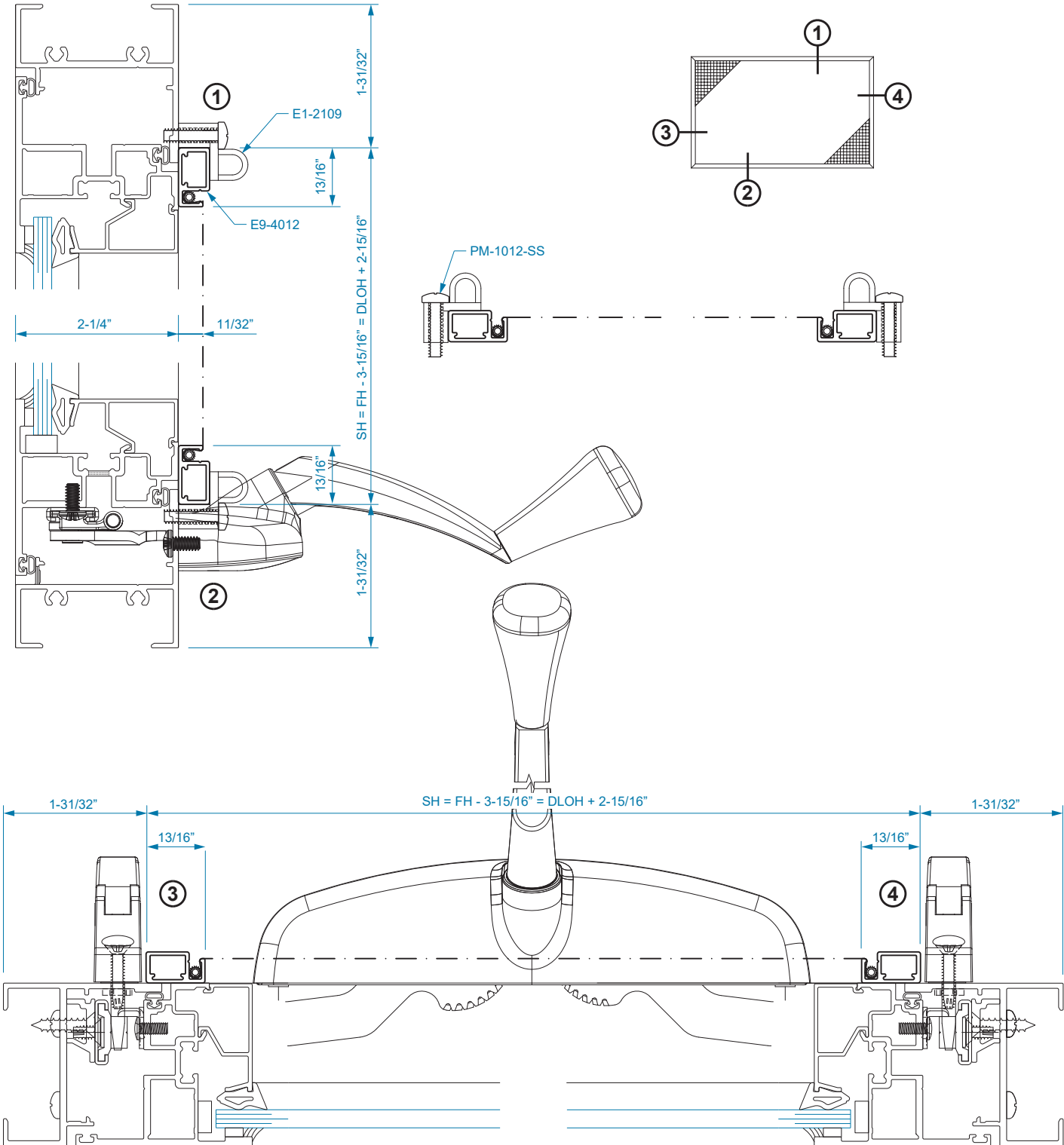

YOW 225 ANCHORING OPTIONS

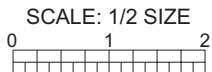
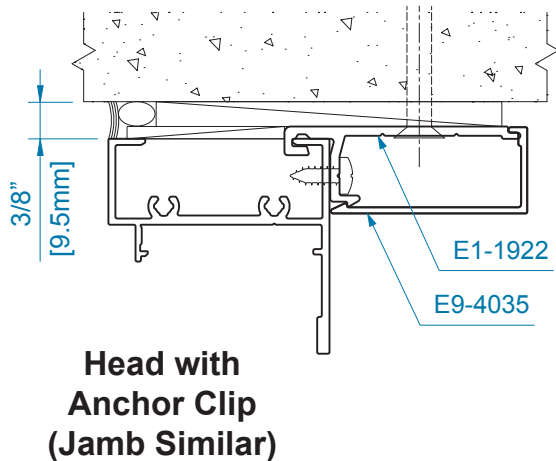
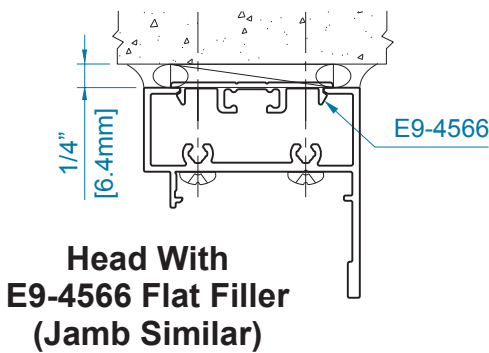
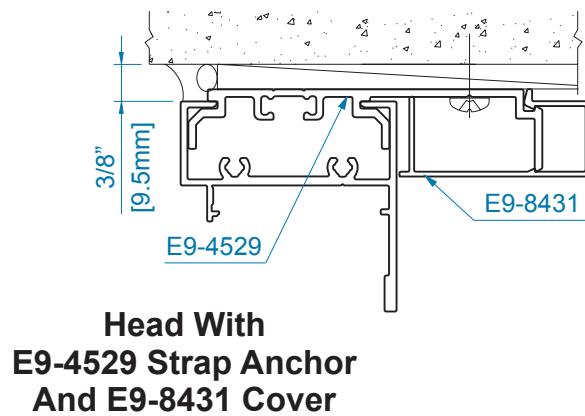
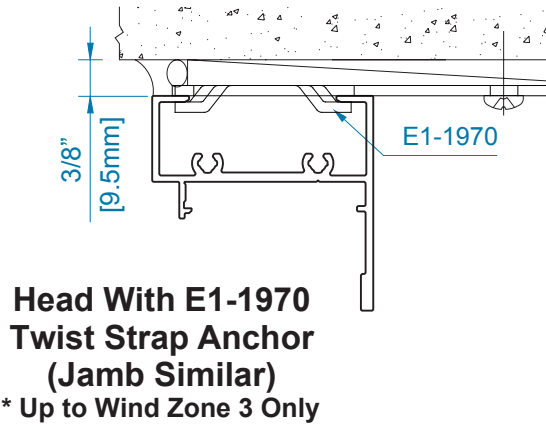
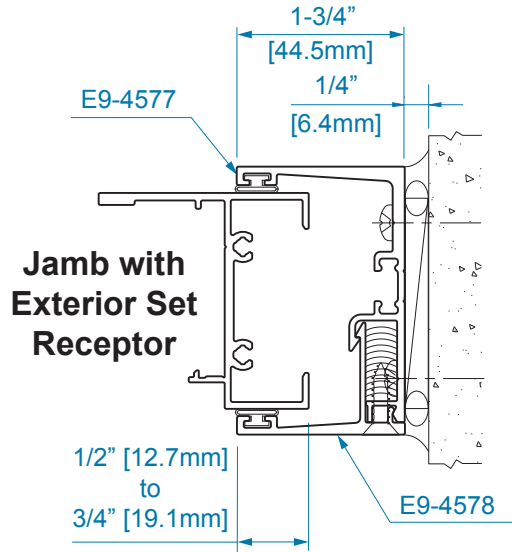
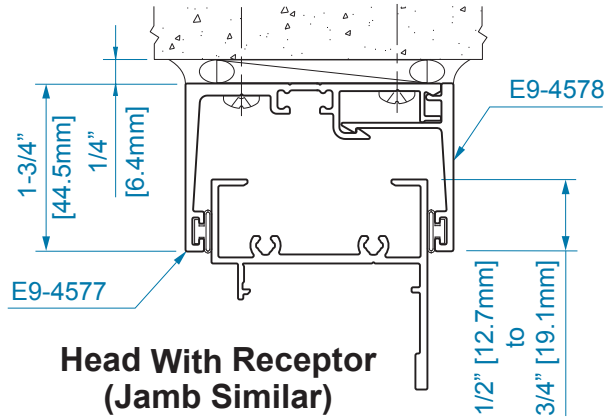

NOTE: Receptors can only be used if end load reaction is less than 450 lbs.
For more information, contact YKK AP.

YOW 225 ANCHORING OPTIONS

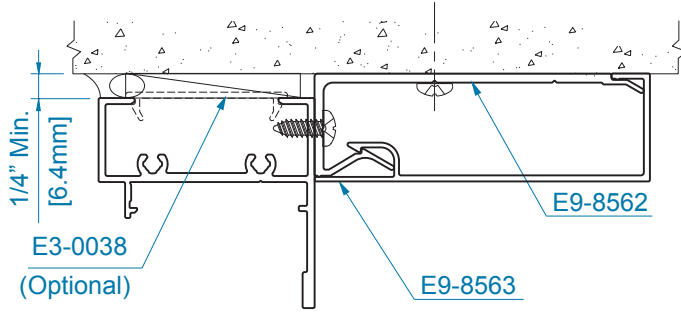

**Head With
 1-1/8" x 3-1/2" Trim & Clip
 (Jamb Similar)**

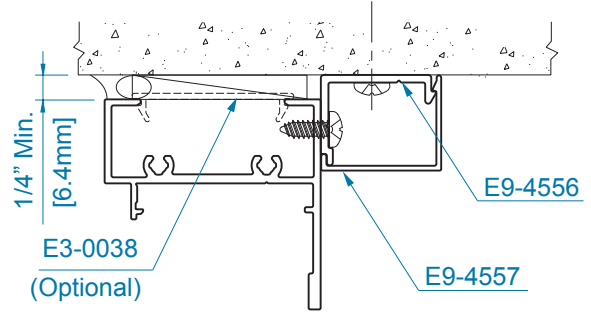

**Head With
 1" x 1-1/4" Trim & Clip
 (Jamb Similar)**

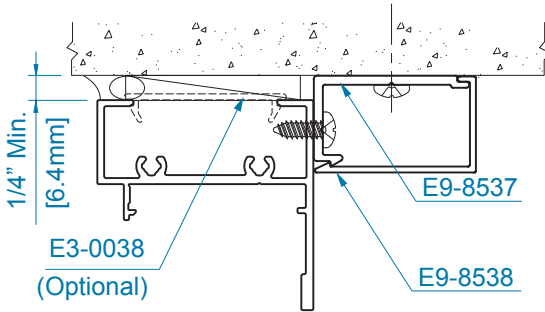

**Head With
 1" x 1-11/16" Trim & Clip
 (Jamb Similar)**

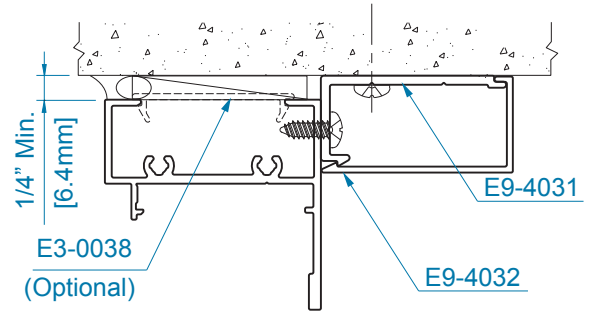

**Head With
 1" x 2" Trim & Clip
 (Jamb Similar)**



SILL FLASHING & EXTERIOR SILL TRIM DETAILS

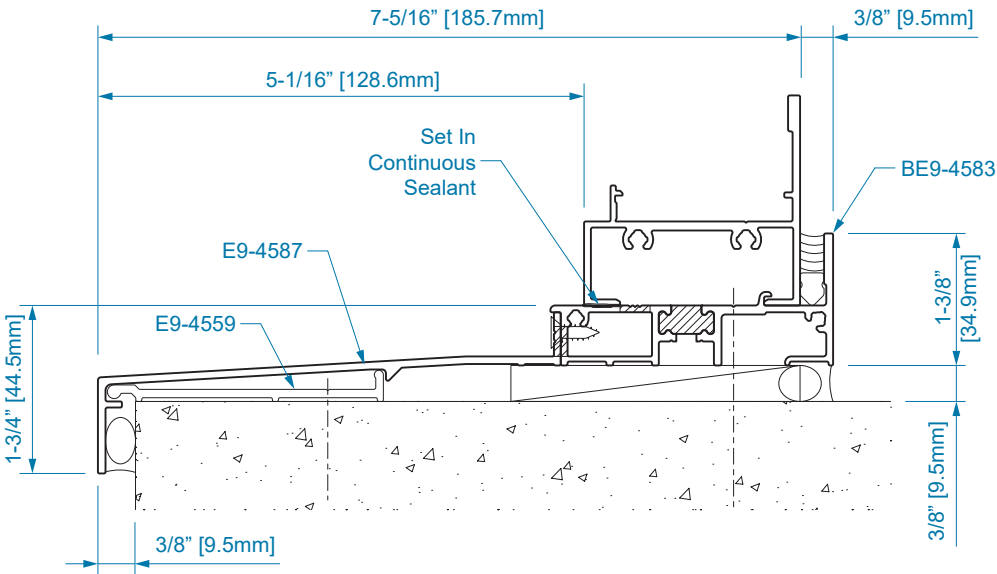
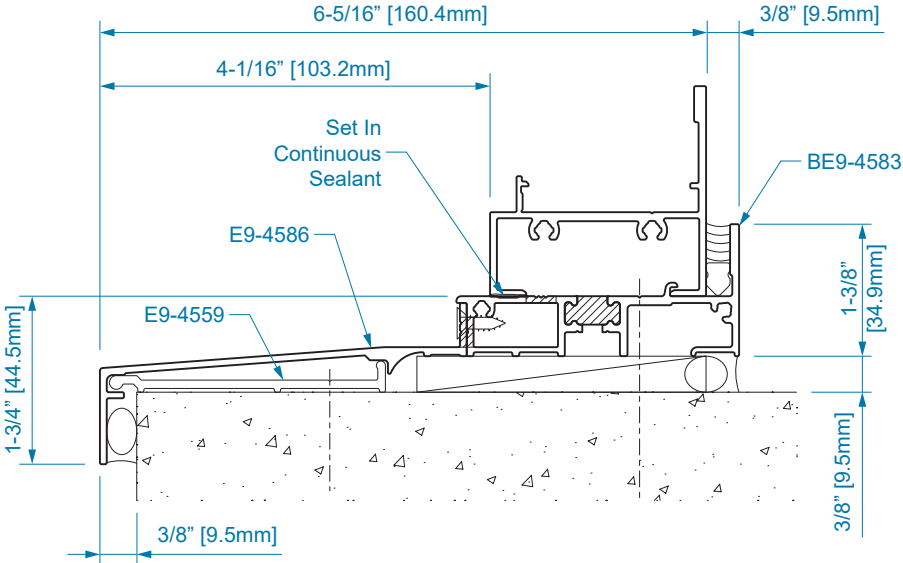

SILL FLASHING & EXTERIOR SILL TRIM DETAILS

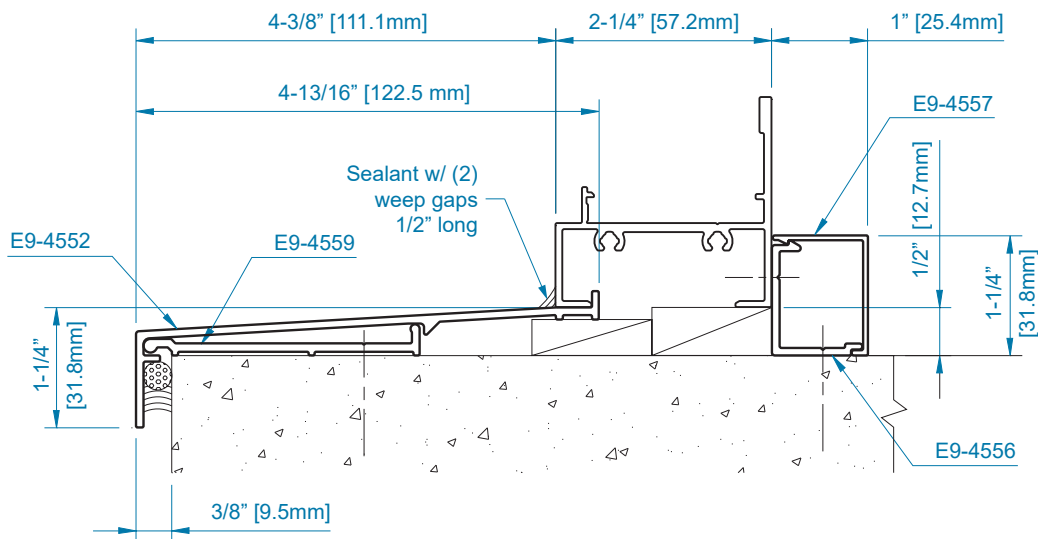
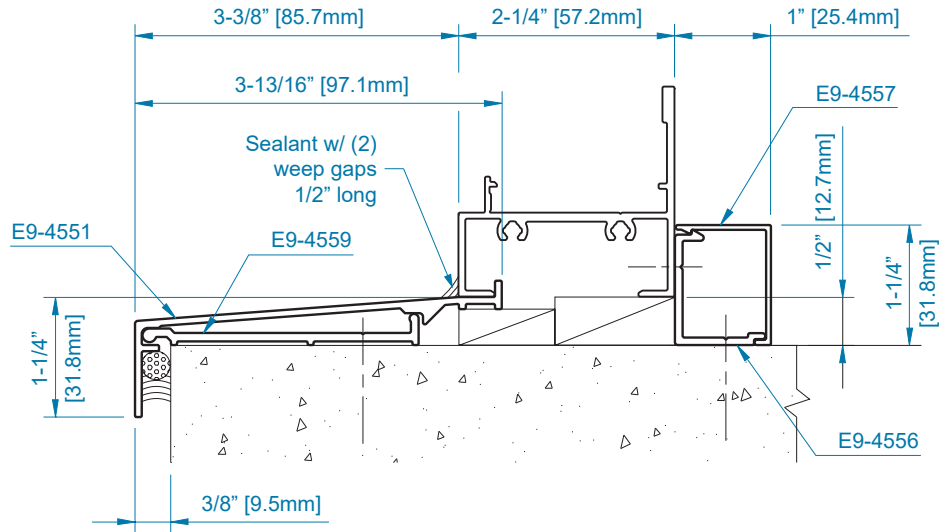

STACKING MULLION OPTIONS (PROJECT OUT, 4-BAR HINGE)

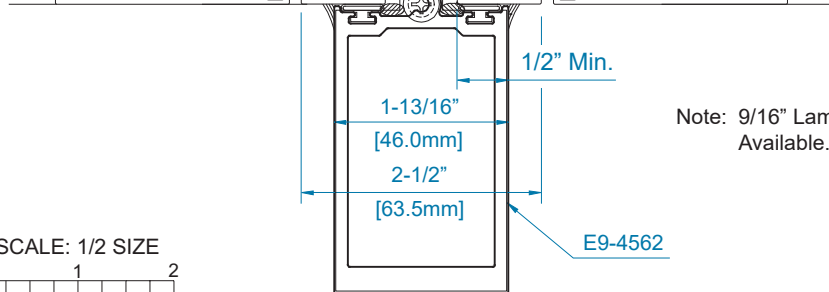
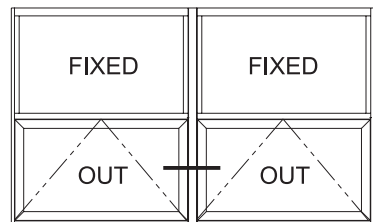
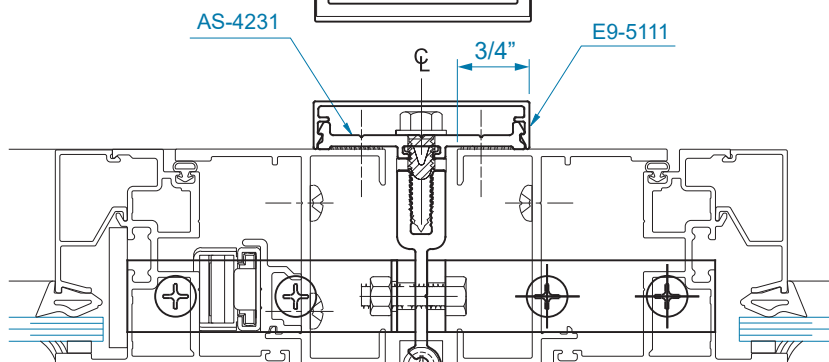
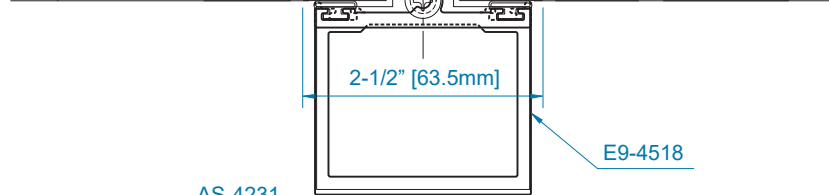
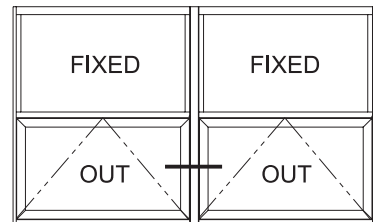
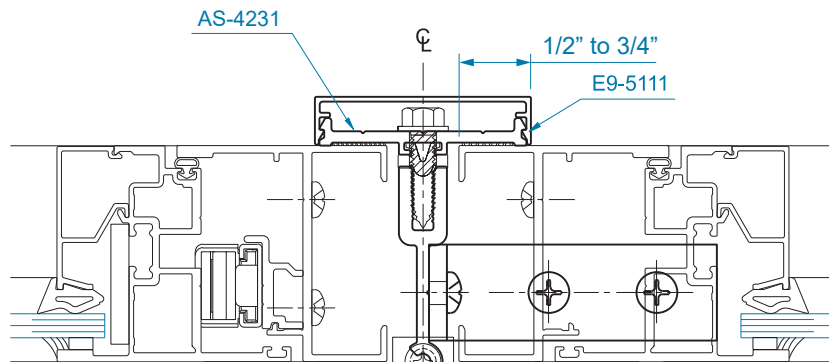
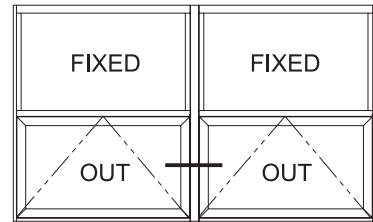
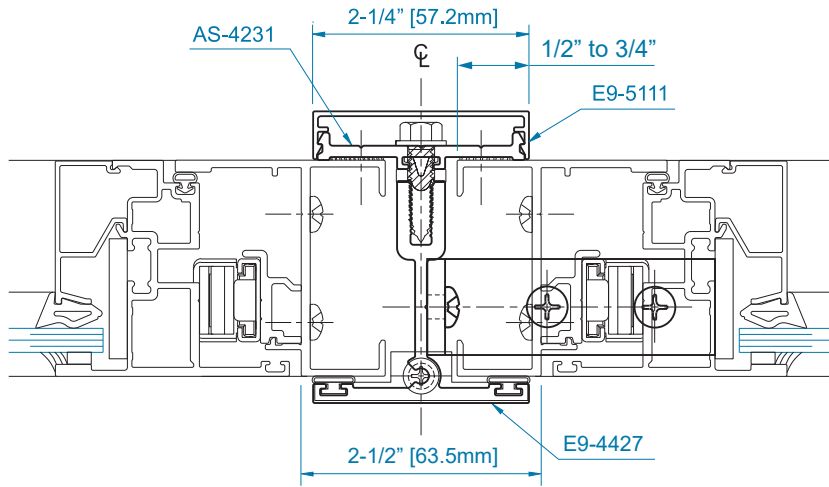

Note: 9/16" Laminated Glazing Option Available.

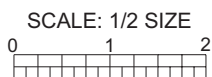

STACKING MULLION OPTIONS (CASEMENT OUTSWING, BUTT HINGE)

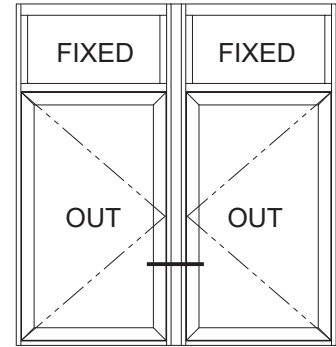
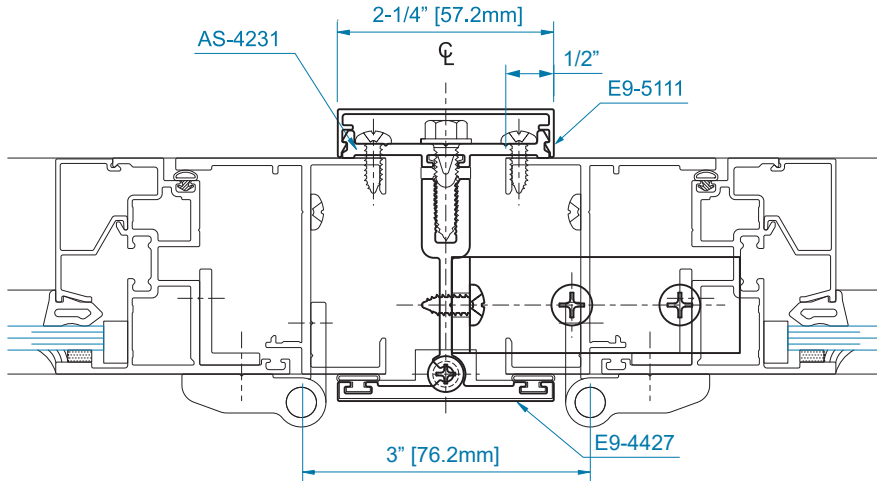

Casement Outswing Shown, Casement Inswing Similar

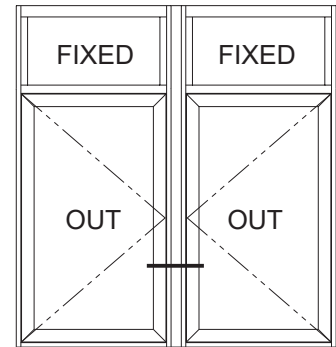
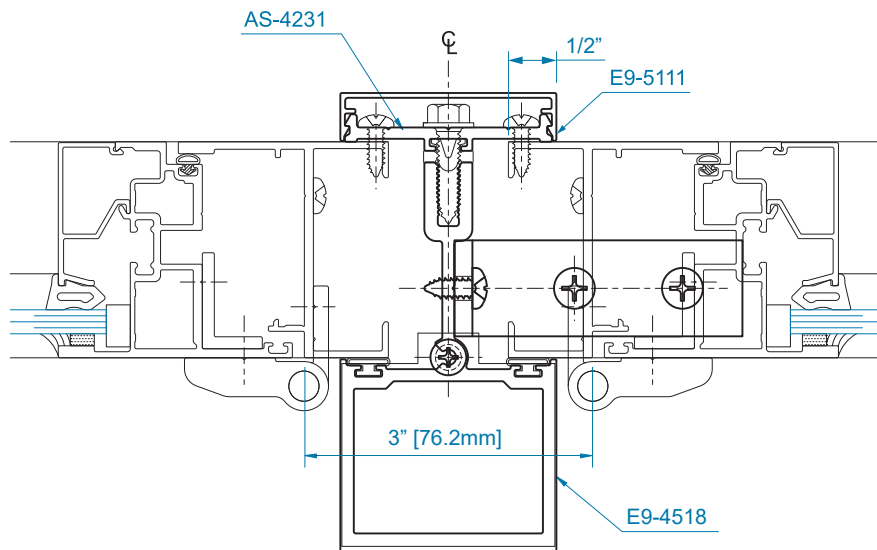

Casement Outswing Shown, Casement Inswing Similar

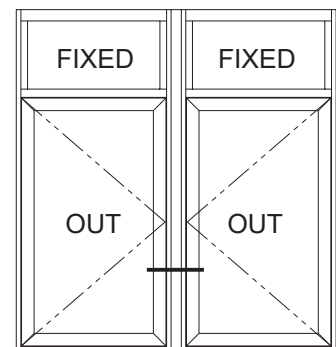
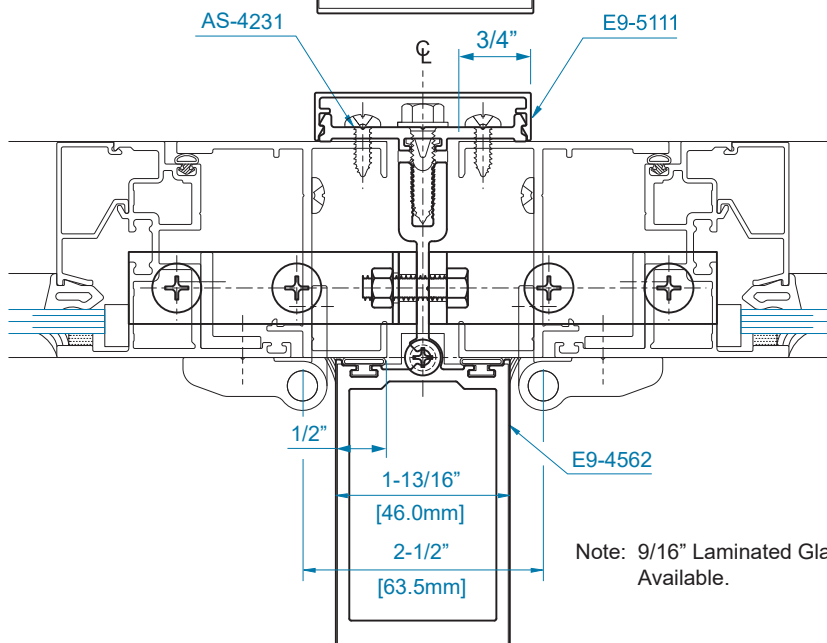

Casement Outswing Only

Note: 9/16" Laminated Glazing Option Available.

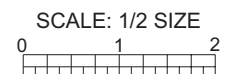

OPTIONAL I-MULLION (WIND ZONE 3 ONLY)

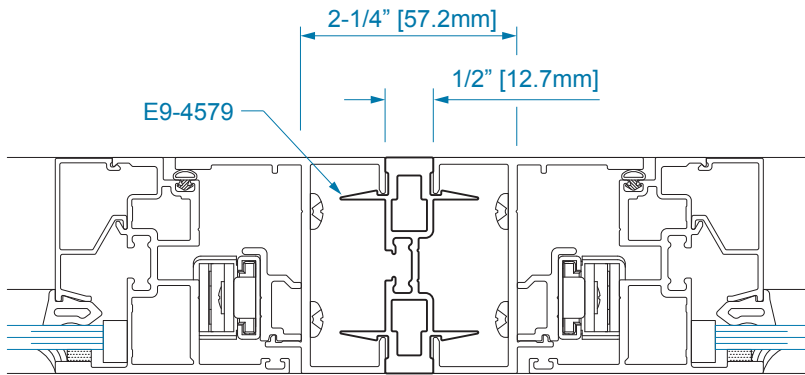

4-BAR HINGES

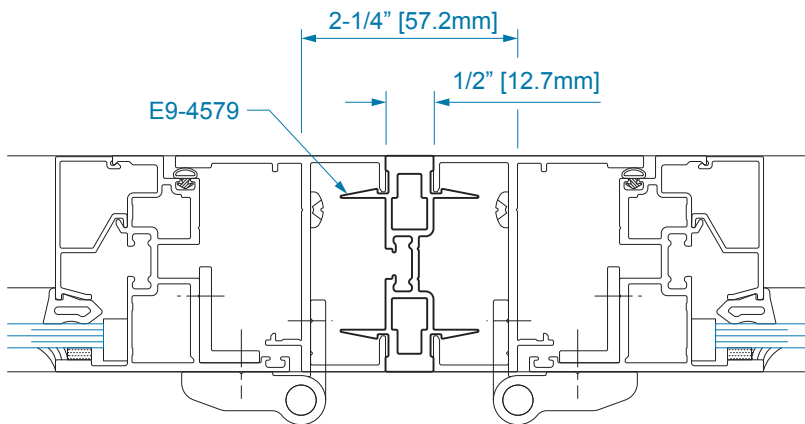
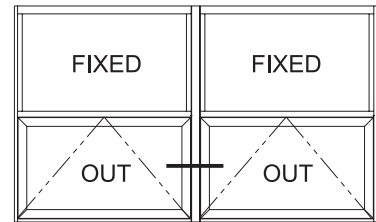

BUTT HINGES

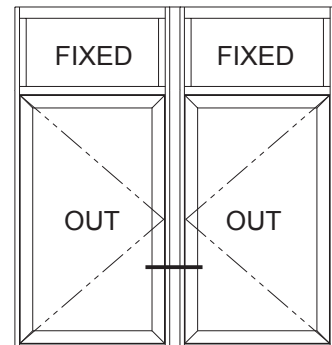

Casement Outswing Shown,
Casement Inswing Similar

Note: 9/16" Laminated Glazing Option Available.

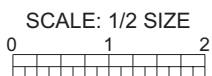

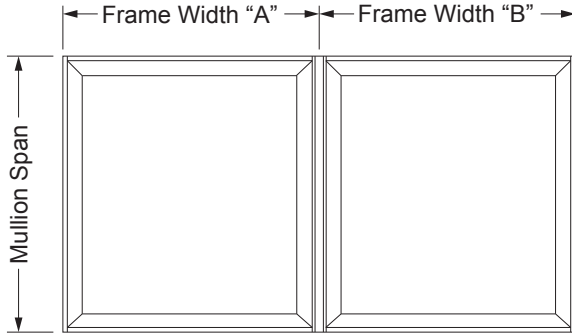

Tributary Width is determined by the following:

$$(\text{Frame Width "A"} + \text{Frame Width "B"}) / 2$$

Refer to Florida Product Approvals for anchoring details and additional information.

Notes:

- 1.) Design pressures are limited either by mullion or anchor screw capacity.
- 2.) Refer to Florida Product Approvals or Engineer of Record for minimum anchor requirements.
- 3.) Design pressures values apply to mullion where two or more windows are listed in a single opening. Lesser design of individual window or mullion of installation shall govern.

E9-4518 Clipped Stacking Mullion Design Pressure Chart									
*1-Maximum Design Pressure Capacity (PSF) +/- (Up to and including Florida's HVHZ - Impact) Used on YOW 225 / YOW 225 H									
Mull Span [Inches]	Tributary Width [Inches] - Frame								
	12	18	24	36	42	48	56	60	62-3/8
35	150.0	148.9	126.3	113.8	113.8	113.8	113.8	113.8	113.8
48	138.3	99.3	80.7	64.5	61.5	60.5	60.5	60.5	60.5
54	121.0	86.1	69.2	53.8	50.3	48.4	47.8	47.8	47.8
62	103.7	73.1	58.1	44.0	40.5	38.2	36.6	36.3	36.3
66	96.8	67.9	53.8	40.3	36.9	34.6	32.8	32.3	32.1
72	88.0	61.5	48.4	35.9	32.5	30.3	28.3	27.7	27.4
80	78.5	54.5	42.7	31.2	28.1	25.9	23.9	23.2	22.9
84	74.5	51.6	40.3	29.3	26.3	24.2	22.2	21.5	21.2

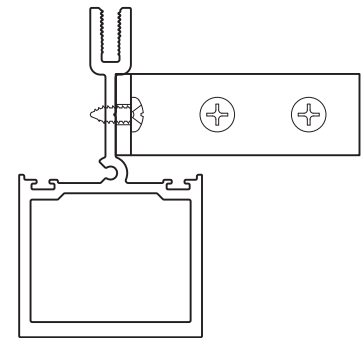

E9-4518 Unclipped Stacking Mullion Design Pressure Chart									
Maximum Design Pressure Capacity (PSF) +/- (Up to and including Florida's HVHZ - Impact) Used on YOW 225 / YOW 225 H									
Mull Span [Inches]	Tributary Width [Inches] - Frame								
	12	18	24	36	42	48	56	60	62-3/8
35	150.0	150.0	150.0	150.0	150.0	150.0	150.0	150.0	150.0
48	150.0	150.0	150.0	150.0	150.0	150.0	150.0	150.0	150.0
54	150.0	150.0	150.0	150.0	150.0	150.0	150.0	150.0	123.1
62	150.0	150.0	150.0	150.0	141.7	131.2	123.6	122.2	81.3
66	150.0	150.0	150.0	137.2	122.4	112.5	104.5	102.3	67.7
72	150.0	150.0	150.0	113.3	100.4	91.4	83.6	81.1	53.3
80	150.0	150.0	130.1	90.2	79.4	71.7	64.6	62.1	40.6
84	150.0	150.0	117.6	81.3	71.3	64.2	57.6	55.2	36.0

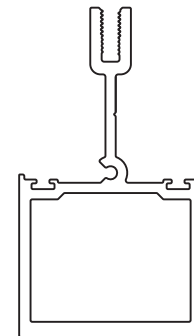

See notes 1, 2, and 3.

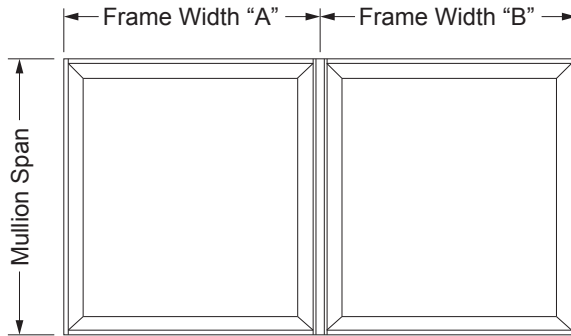

Tributary Width is determined by the following:

$$(\text{Frame Width "A"} + \text{Frame Width "B"}) / 2$$

Refer to Florida Product Approvals for anchoring details and additional information.

Notes:

- 1.) Design pressures are limited either by mullion or anchor screw capacity.
- 2.) Refer to Florida Product Approvals or Engineer of Record for minimum anchor requirements.
- 3.) Design pressures values apply to mullion where two or more windows are listed in a single opening. Lesser design of individual window or mullion of installation shall govern.

E9-4527 Clipped Stacking Mullion Design Pressure Chart								
Maximum Design Pressure Capacity (PSF) +/- (Up to and including Florida's HVHZ - Impact) Used on YOW 225 / YOW 225 H								
Mull Span [Inches]	Tributary Width [Inches] - Frame							
	12	18	24	36	42	48	56	60
35	150.0	148.9	126.3	113.8	113.8	113.8	113.8	113.8
48	138.3	99.3	80.7	64.5	61.5	60.5	60.5	60.5
54	121.0	86.1	69.2	53.8	50.3	48.4	47.8	47.8
62	103.7	73.1	58.1	44.0	40.5	38.2	36.6	36.3

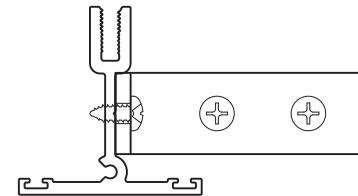

See notes 1, 2, and 3.

E9-4527 Unclipped Stacking Mullion Design Pressure Chart								
Maximum Design Pressure Capacity (PSF) +/- (Up to and including Florida's HVHZ - Impact) Used on YOW 225 / YOW 225 H								
Mull Span [Inches]	Tributary Width [Inches] - Frame							
	12	18	24	36	42	48	56	60
35	150.0	150.0	150.0	150.0	150.0	150.0	150.0	150.0
48	150.0	150.0	150.0	133.7	125.1	122.3	122.3	122.3
54	150.0	150.0	137.9	100.8	92.2	87.4	85.9	85.9
62	150.0	134.0	102.8	73.4	65.9	61.0	57.5	56.8

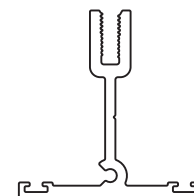

See notes 1, 2, and 3.

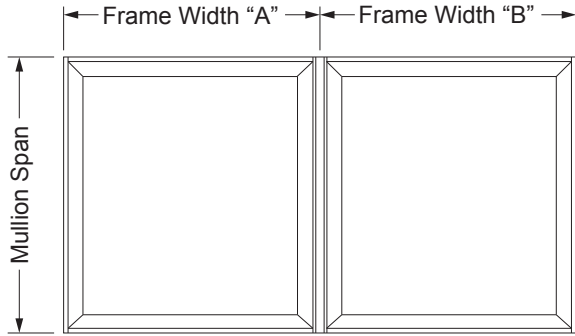

Tributary Width is determined by the following:

$$(\text{Frame Width "A"} + \text{Frame Width "B"}) / 2$$

Refer to Florida Product Approvals for anchoring details and additional information.

E9-4562 Clipped Stacking Mullion Design Pressure Chart								
Maximum Design Pressure Capacity (PSF) +/- (Up to and including Florida's HVHZ - Impact) Used on YOW 225 / YOW 225 H								
Mull Span [Inches]	Tributary Width [Inches] - Frame							
	12	18	24	36	42	48	56	60
68	150.0	150.0	150.0	150.0	150.0	150.0	150.0	142.3
72	150.0	150.0	150.0	150.0	148.1	143.0	138.5	130.9
76	150.0	150.0	150.0	150.0	137.9	133.0	128.6	121.2
80	150.0	150.0	150.0	140.6	127.4	121.7	116.6	108.1
84	150.0	150.0	143.9	127.4	114.8	109.6	104.9	97.0
88	150.0	150.0	130.6	115.5	104.0	99.2	94.9	87.6
92	150.0	137.9	119.2	105.3	94.7	90.2	86.3	79.6
93-1/8	150.0	134.5	116.2	102.7	92.3	87.9	84.1	77.5

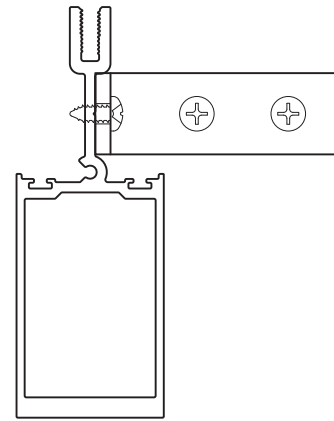

See notes 1, 2, and 3 on previous page.

E9-4579 Unclipped 'I' Mullion Design Pressure Chart											
Maximum Design Pressure Capacity (PSF) +/- (Up to and including Florida's WZ3 - Impact) Used on YOW 225 / YOW 225 H											
Mull Span [Inches]	Tributary Width [Inches] - Frame										
	30	32	34	36	38	40	42	44	46	48	50
47	65.0	65.0	65.0	65.0	65.0	65.0	65.0	65.0	65.0	65.0	65.0
49	65.0	65.0	65.0	65.0	65.0	65.0	65.0	65.0	65.0	65.0	-
51	65.0	65.0	65.0	65.0	65.0	65.0	65.0	65.0	65.0	-	-
53	65.0	65.0	65.0	65.0	65.0	65.0	65.0	65.0	-	-	-
56	65.0	65.0	65.0	65.0	65.0	65.0	65.0	-	-	-	-
59	65.0	65.0	65.0	65.0	65.0	65.0	-	-	-	-	-
62	65.0	65.0	65.0	65.0	65.0	-	-	-	-	-	-
66	65.0	65.0	65.0	65.0	-	-	-	-	-	-	-
70	65.0	65.0	65.0	-	-	-	-	-	-	-	-
74	65.0	65.0	-	-	-	-	-	-	-	-	-
*80	65.0	-	-	-	-	-	-	-	-	-	-

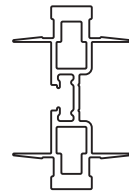

See notes 1, 2, and 3 on previous page.

* 80" Maximum Casement Frame Height

80-3/8" Maximum Fixed Frame Height or Combination Window Height

OPTIONAL SCREEN CONFIGURATIONS

**FIXED SCREEN
CASEMENT INSWING
PROJECT IN**
(INSTALLED ON EXTERIOR)

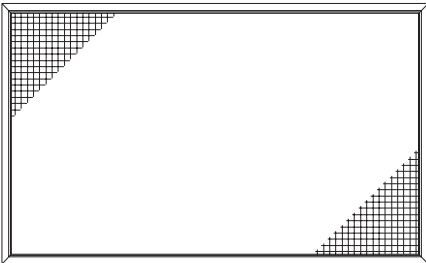
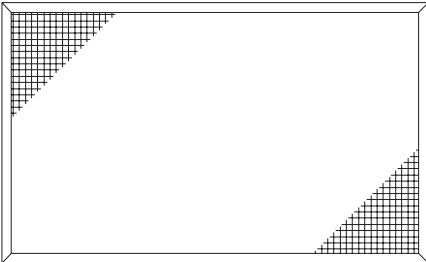

LOW PROFILE

**HINGED WICKET
PROJECT OUT**
(INSTALLED ON INTERIOR)

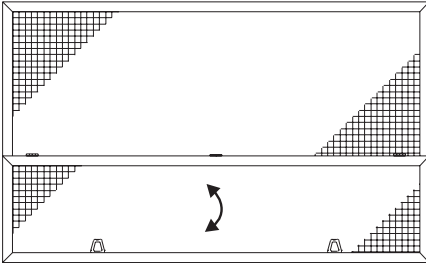

**HINGED WICKET
CASEMENT OUTSWING**
(INSTALLED ON INTERIOR)

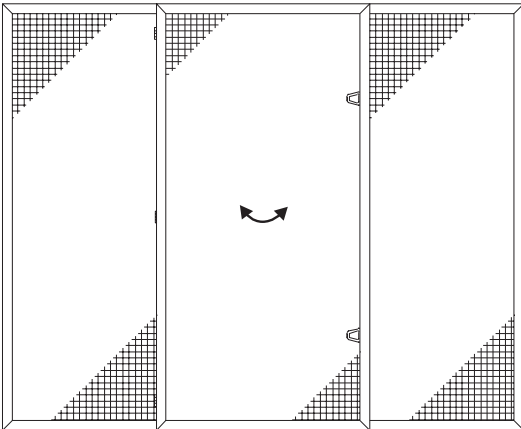
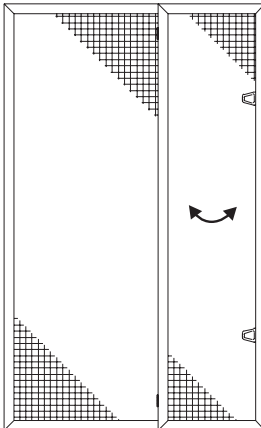

For additional information, contact YKK AP.

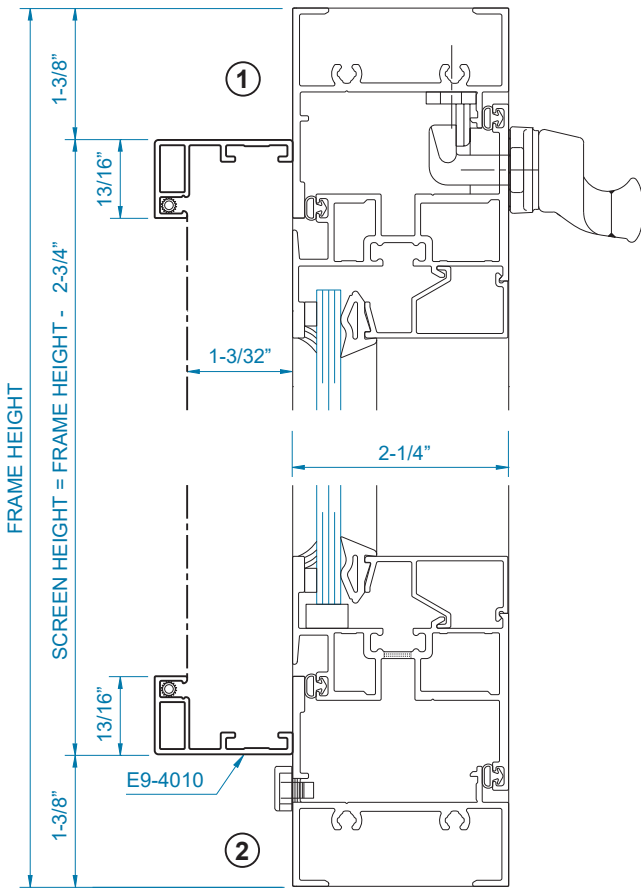

**FIXED WINDOW SCREEN FOR INSWING
(INSTALLED ON EXTERIOR)**

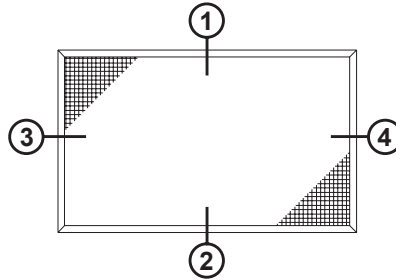

SCREEN ATTACHMENT OPTIONS

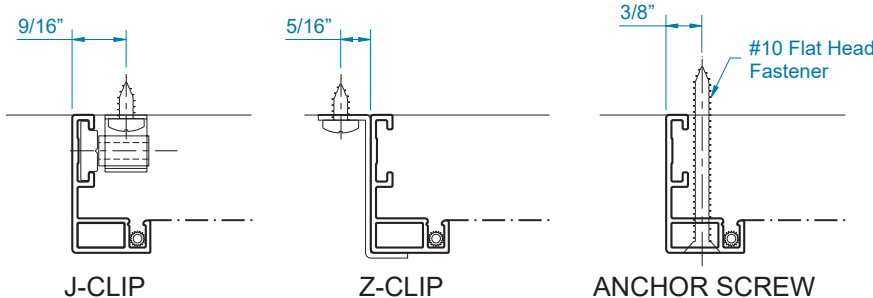
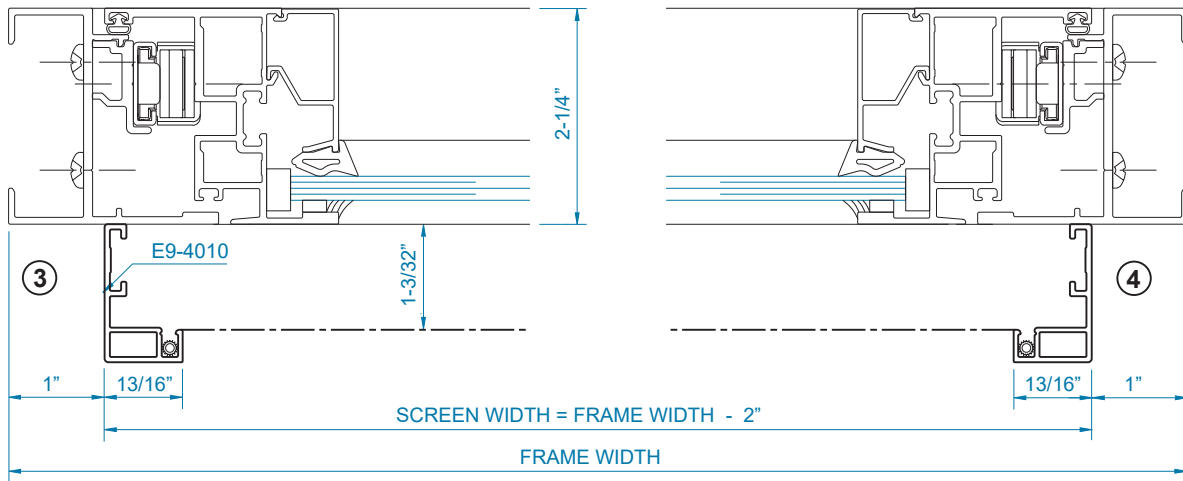
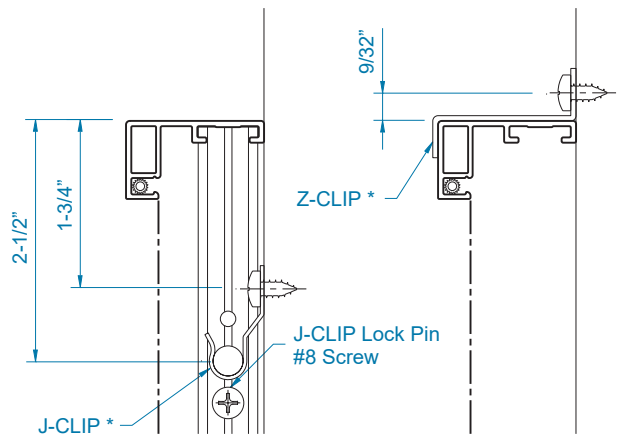

* Clip not finished to match screen or window



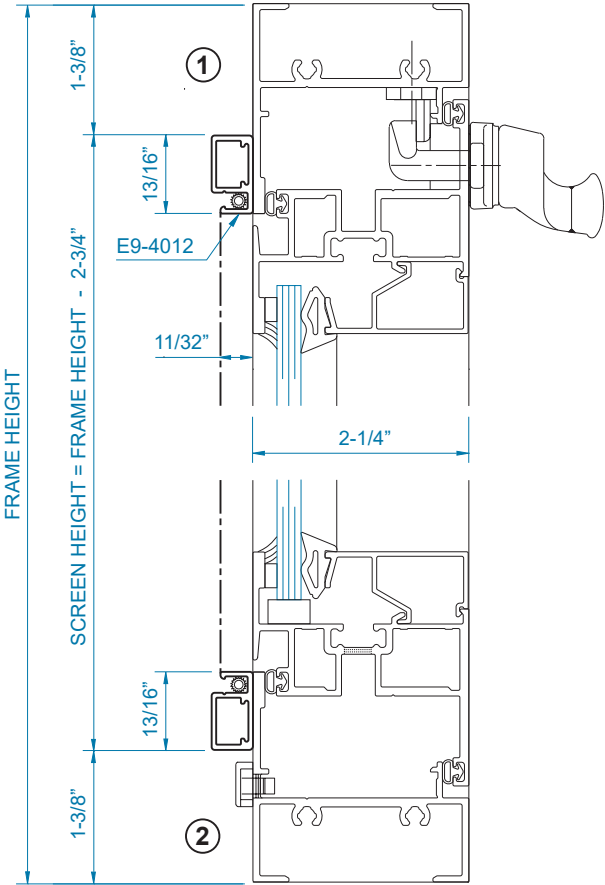

**FIXED WINDOW SCREEN FOR INSWING
LOW PROFILE
(INSTALLED ON EXTERIOR)**

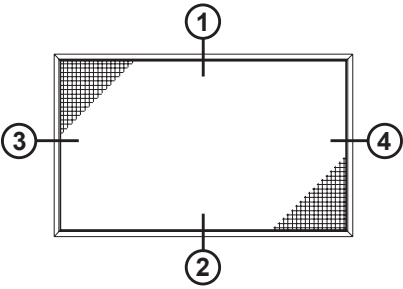

SCREEN ATTACHMENT OPTIONS

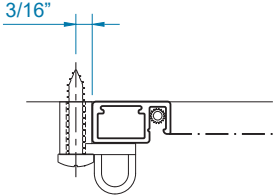
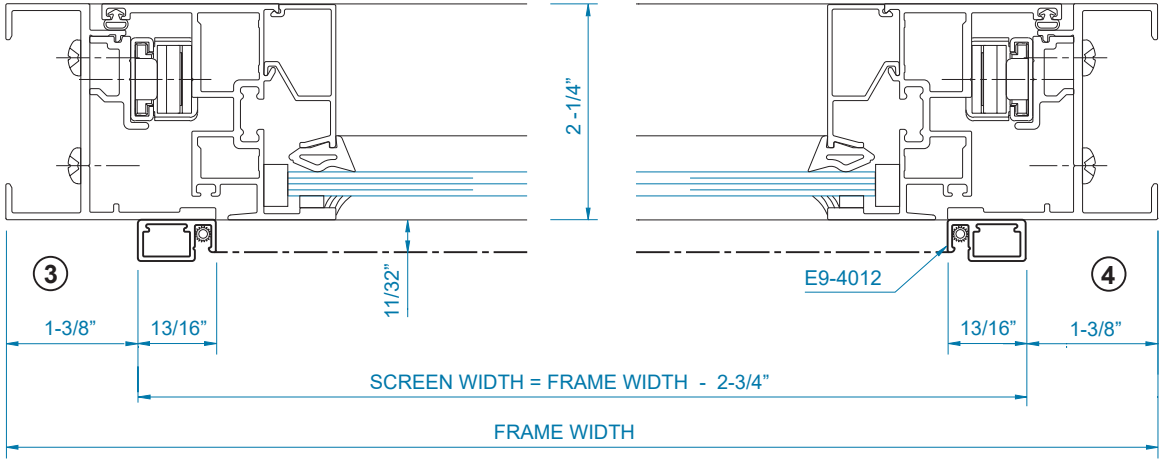
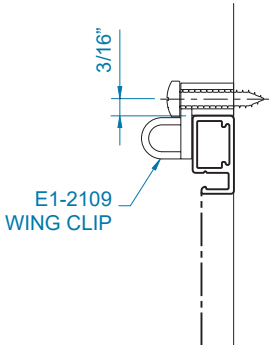

WING CLIP

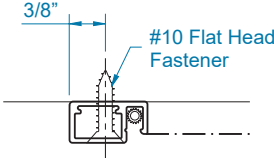

ANCHOR SCREW

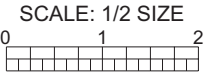

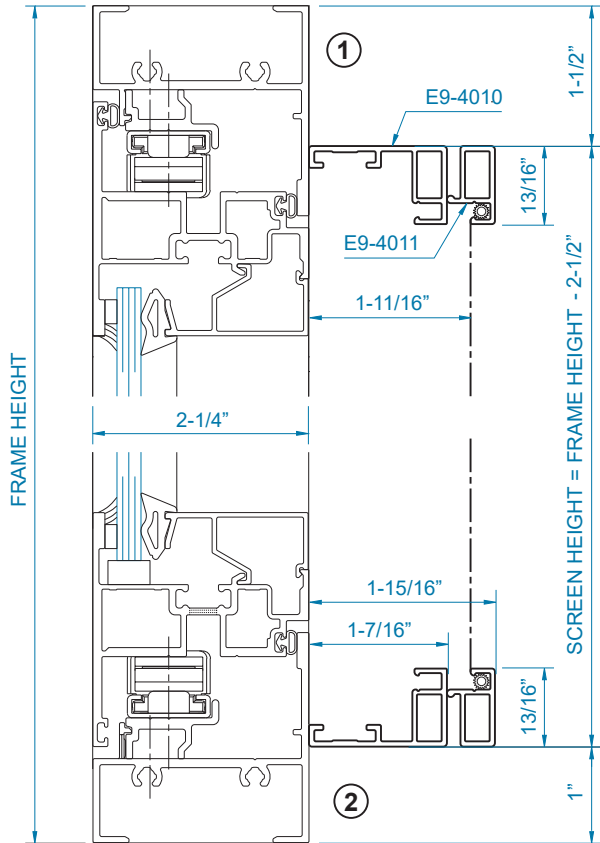

**SCREEN FOR CASEMENT OUTSWING
(INSTALLED ON INTERIOR,
SHOWN WITH CAM LOCKS)**

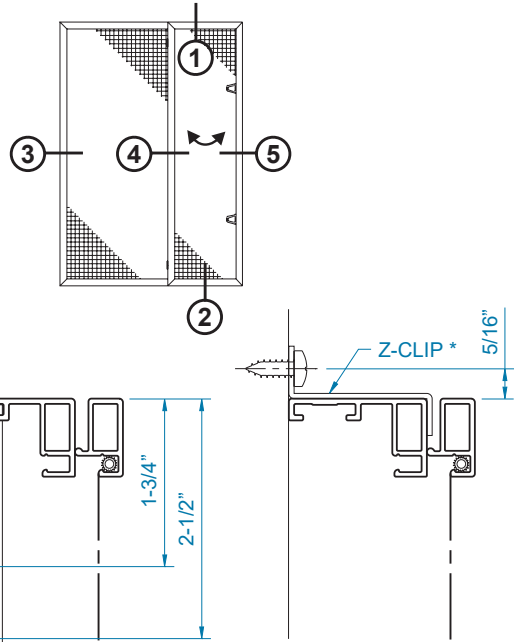

SCREEN ATTACHMENT OPTIONS

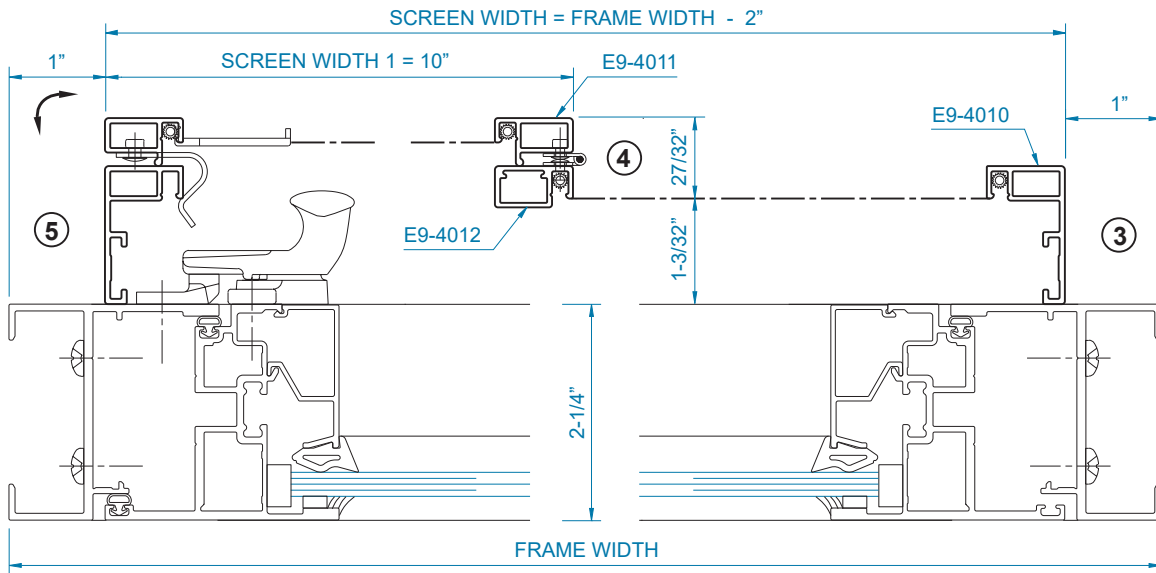

* Clip not finished to match screen or window

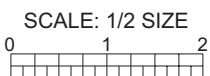
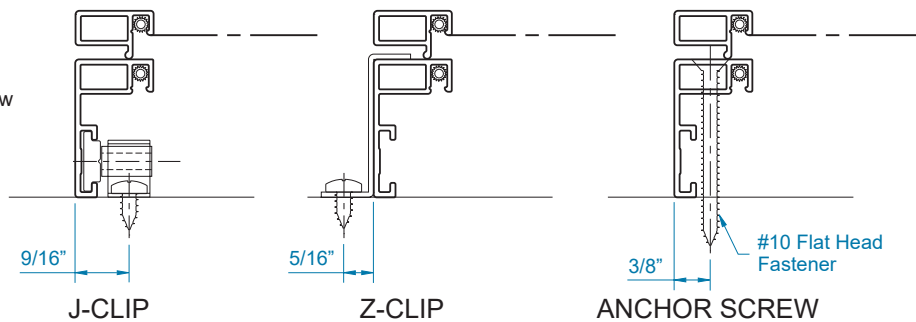

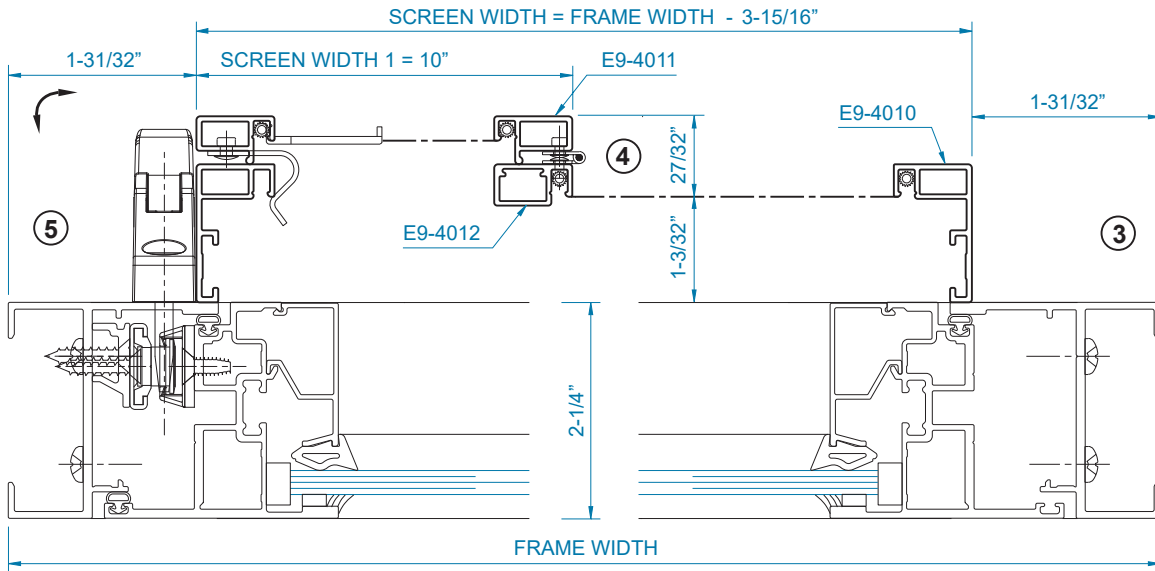
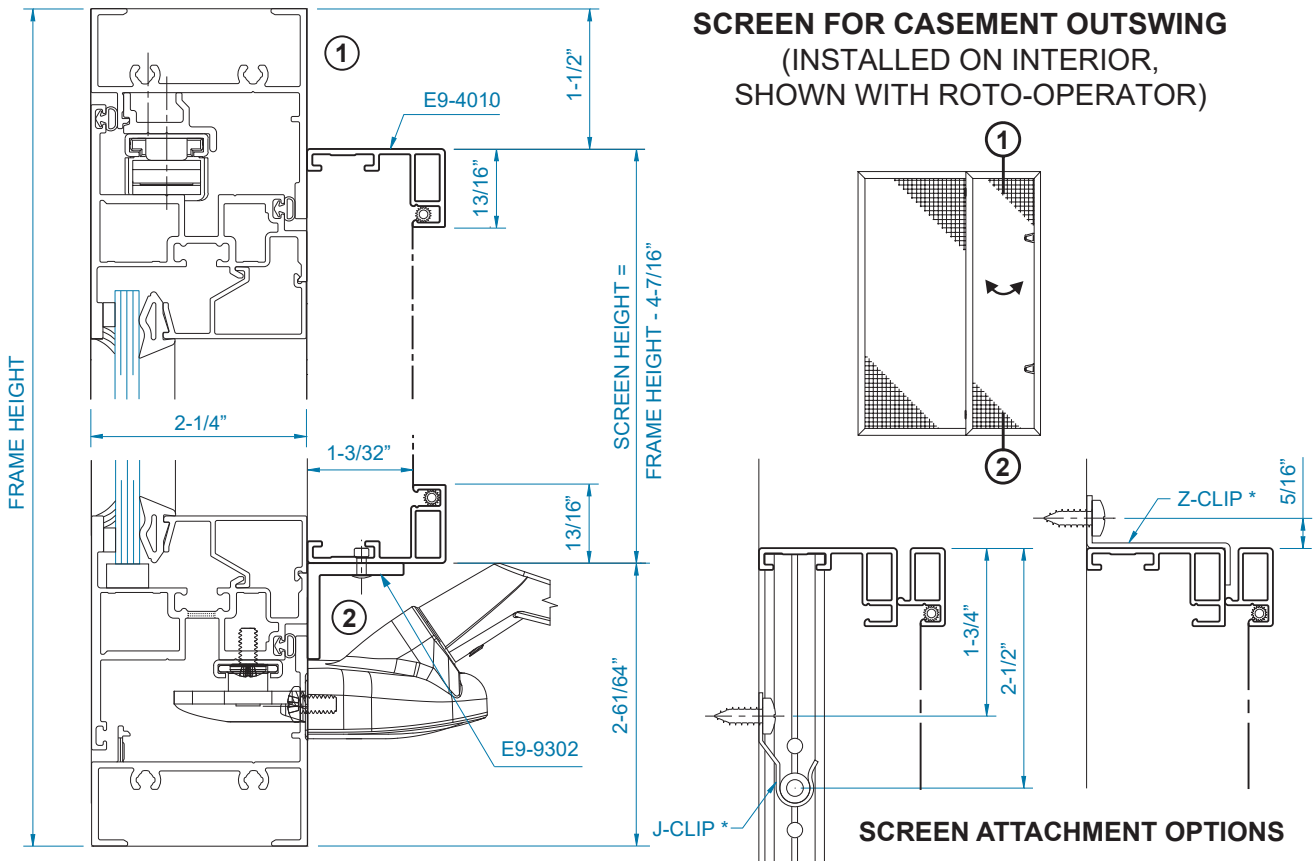

* Clip not finished to match screen or window

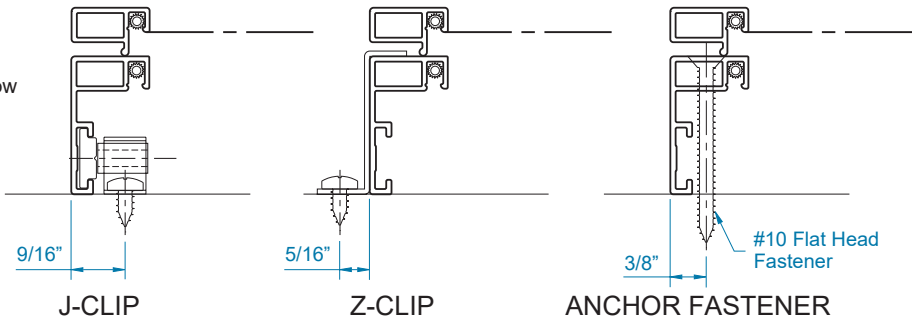
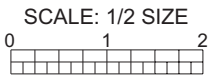

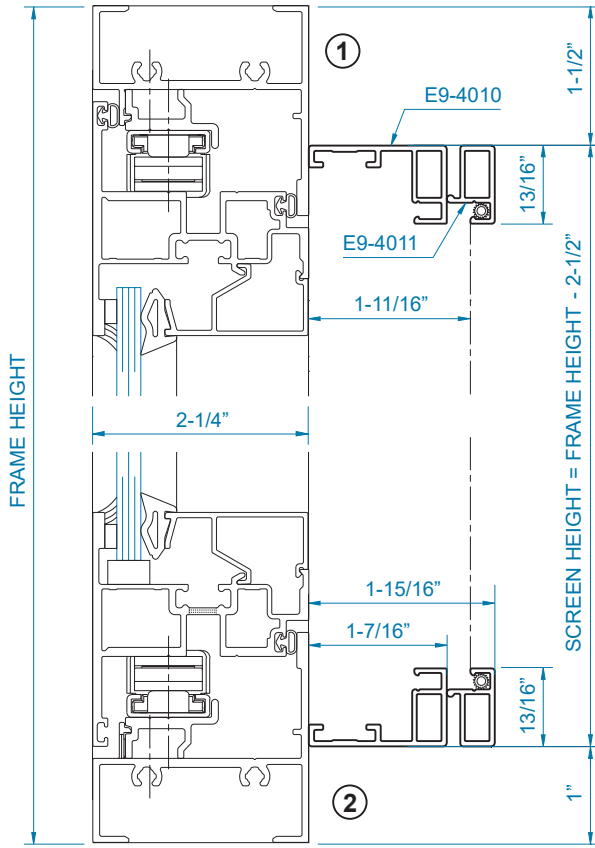

**SCREEN FOR DOUBLE CASEMENT OUTSWING
(INSTALLED ON INTERIOR,
SHOWN WITH CAM LOCKS)**

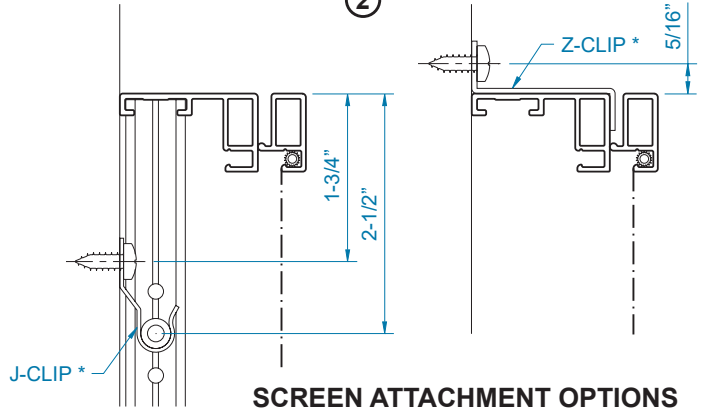
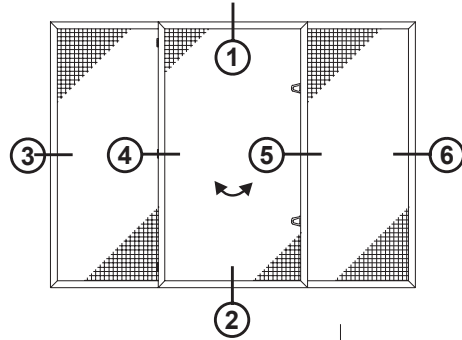

SCREEN ATTACHMENT OPTIONS

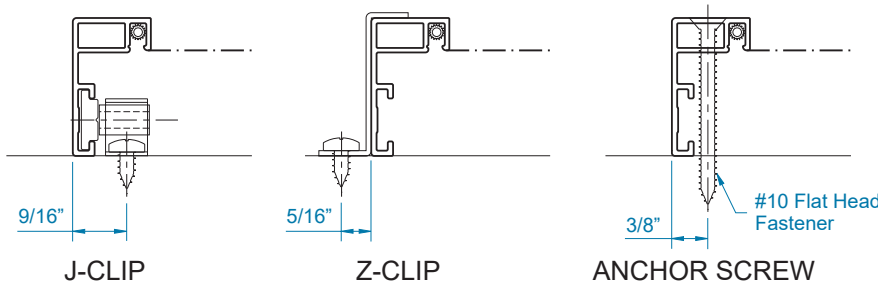
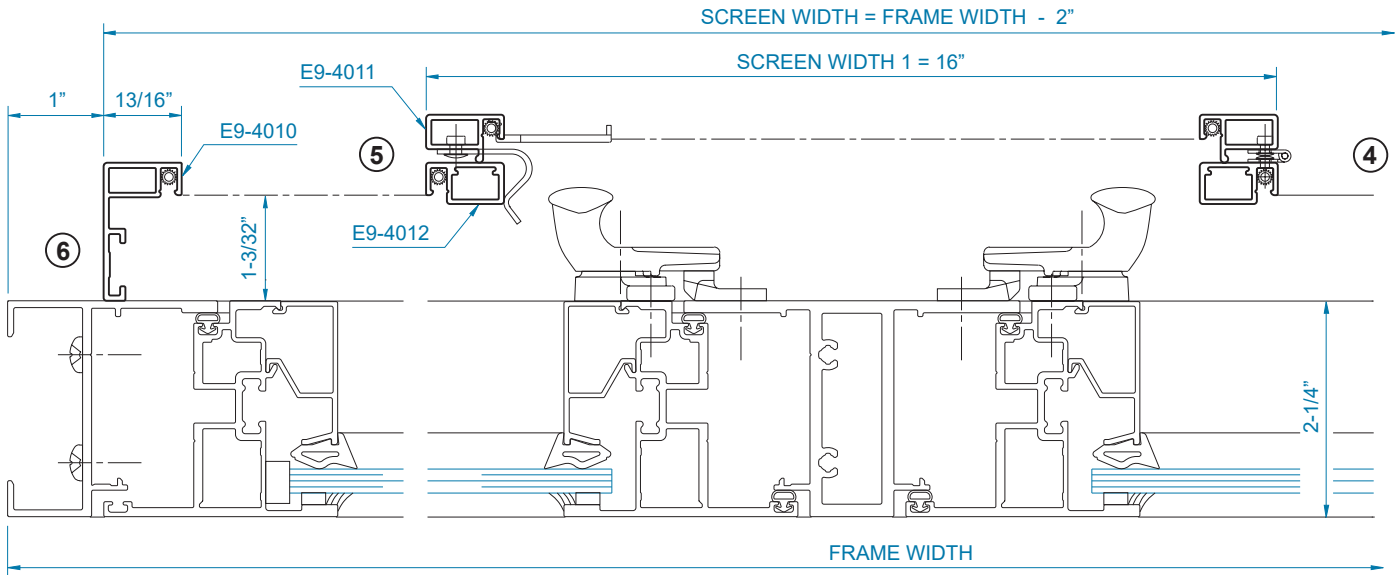

* Clip not finished to match screen or window

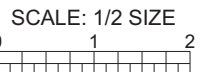

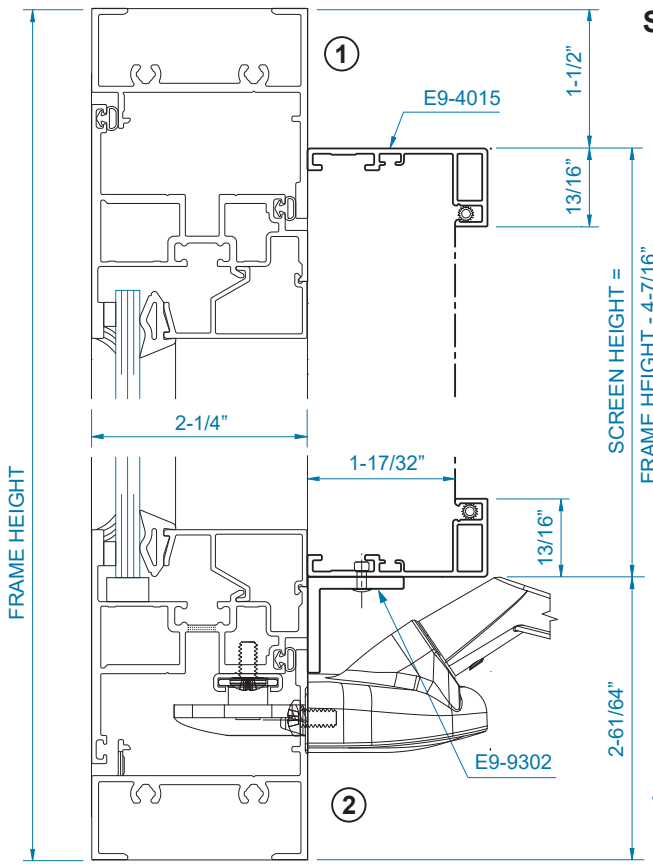

**SCREEN FOR DOUBLE CASEMENT OUTSWING
(INSTALLED ON INTERIOR,
SHOWN WITH ROTO-OPERATOR)**

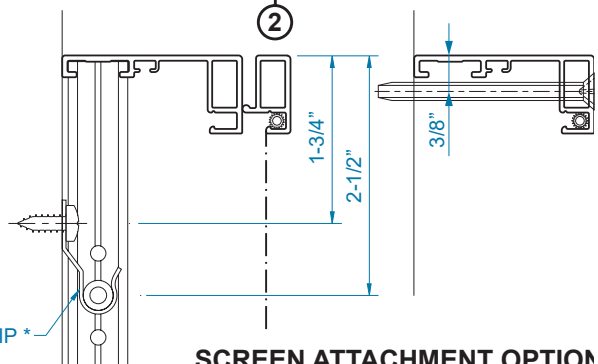
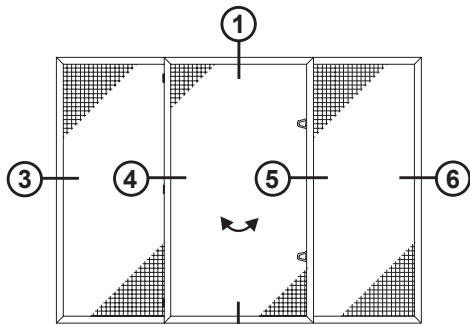

* Clip not finished to match screen or window

SCREEN WIDTH = FRAME WIDTH - 2"

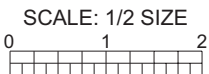
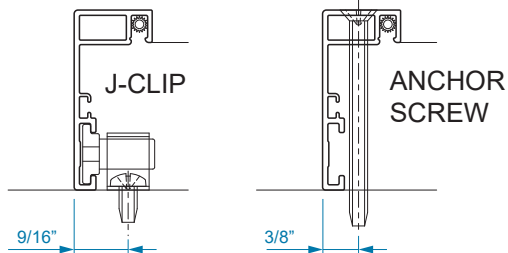
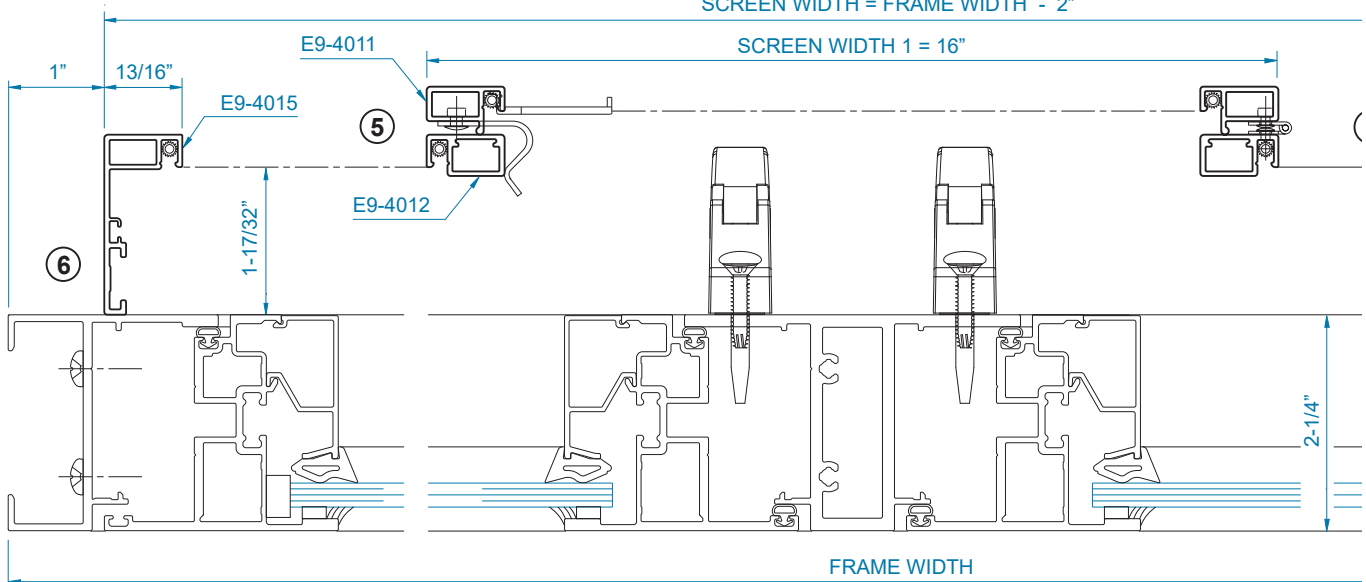

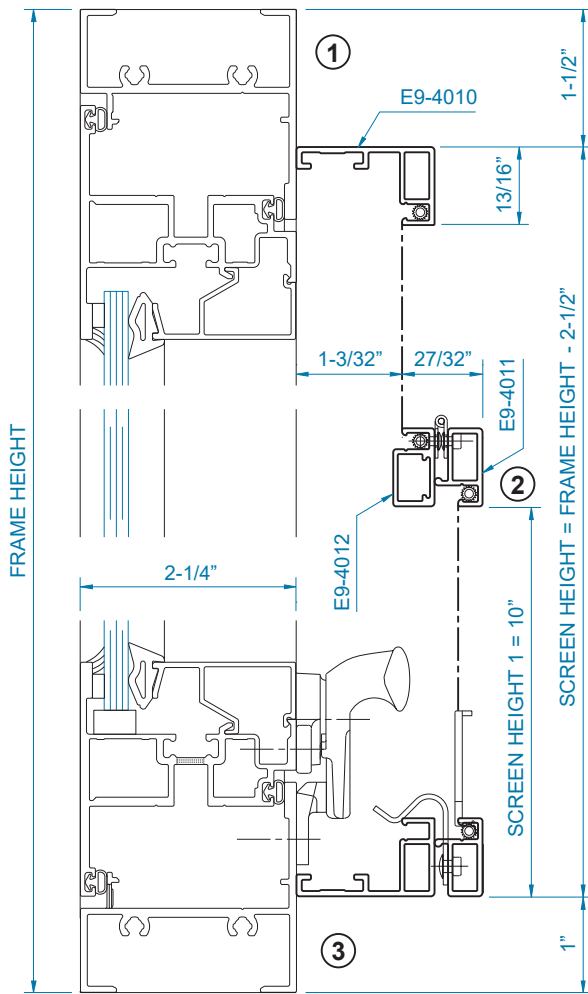

**SCREEN FOR PROJECT OUT
 (INSTALLED ON INTERIOR)**

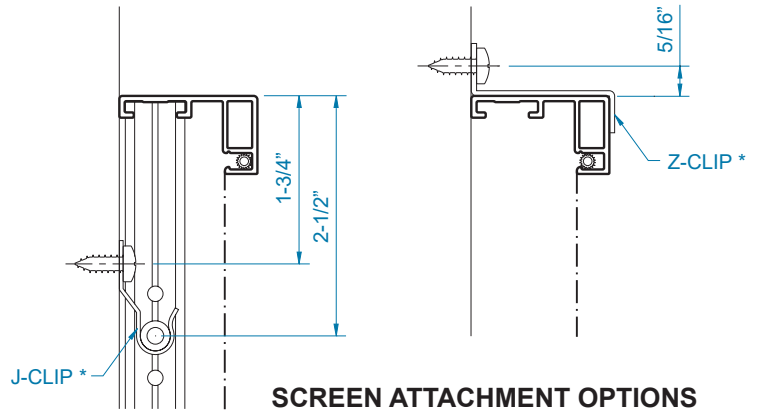
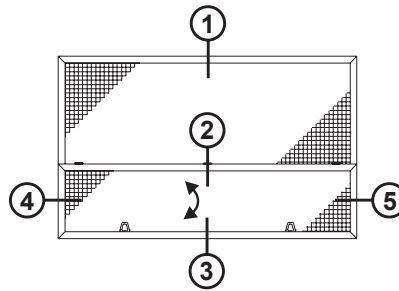

SCREEN ATTACHMENT OPTIONS

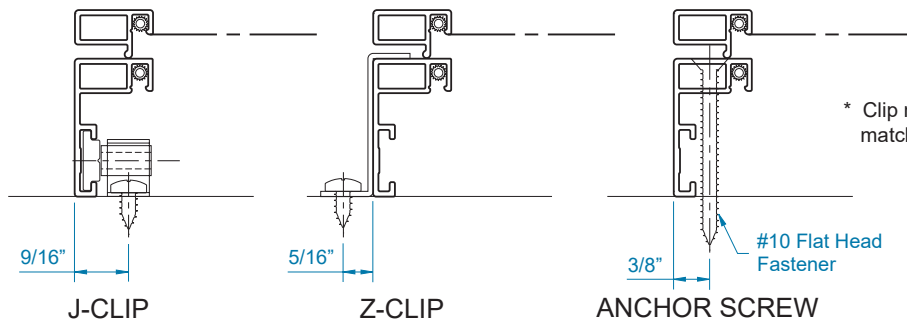
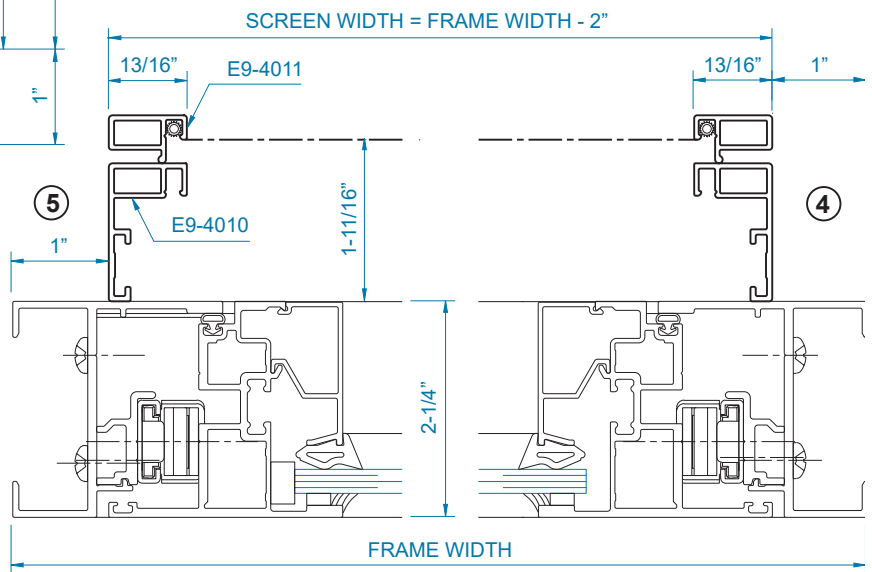

* Clip not finished to match screen or window

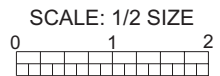

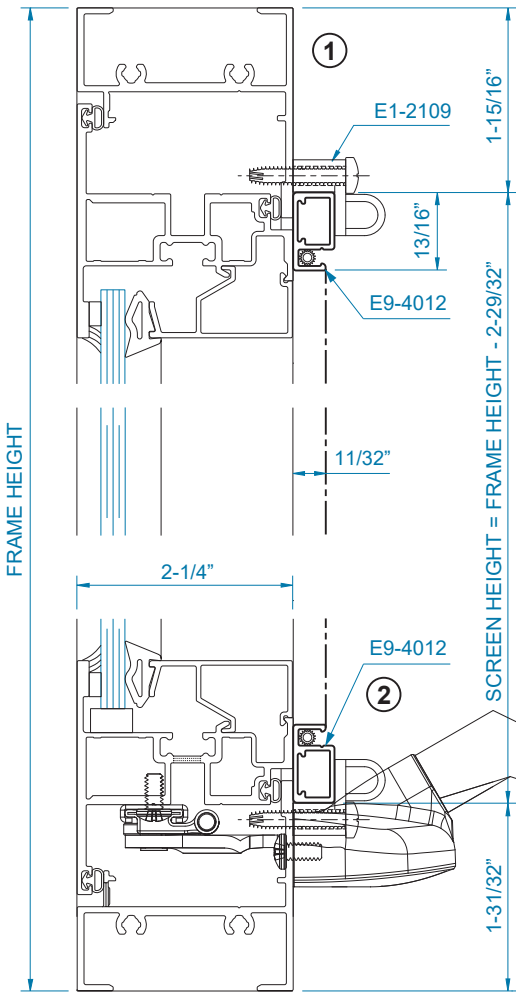

**SCREEN FOR PROJECT OUT
LOW PROFILE
(INSTALLED ON INTERIOR, SHOWN
WITH ROTO-OPERATOR & FMPL)**

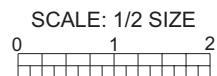
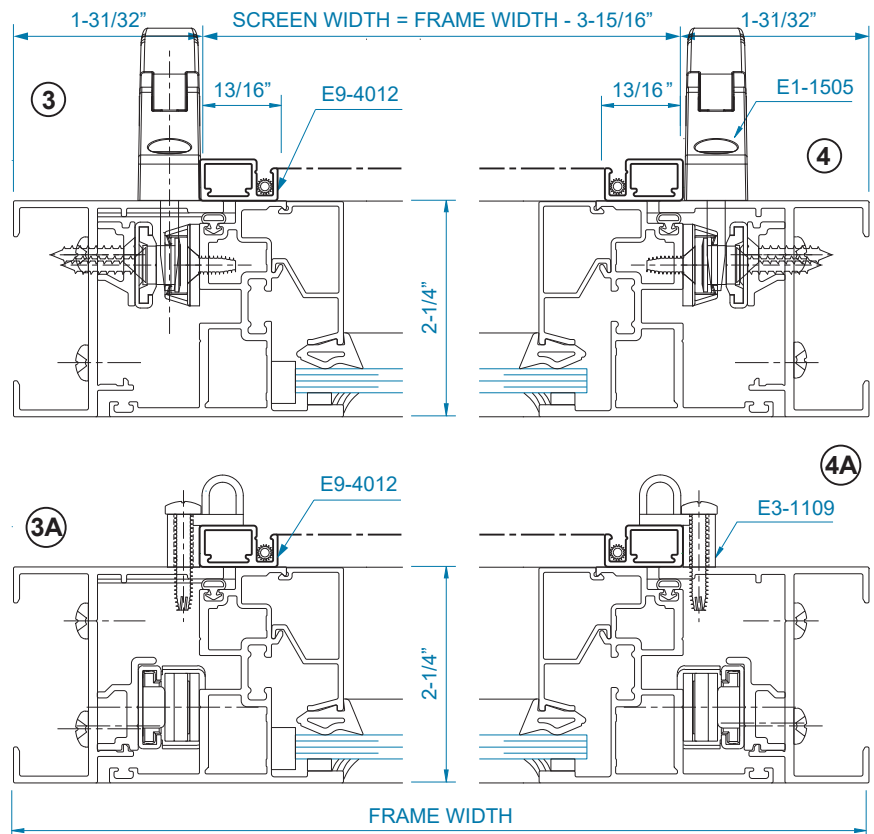
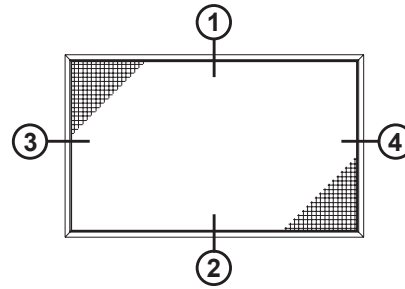

FIXED WINDOW

YOW 225 SIZE LIMITATIONS: (Based on AW-100 Designation)

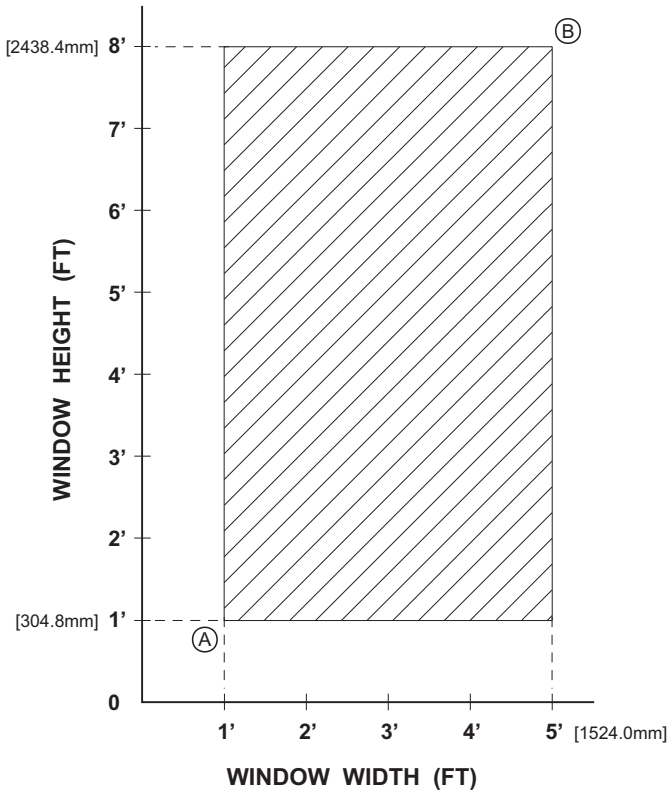

	WINDOW WIDTH	WINDOW HEIGHT
Ⓐ MINIMUM SIZE	12" [304.8mm]	12" [304.8mm]
Ⓑ MAXIMUM SIZE	60" [1524.0mm]	96" [2438.4mm]

CASEMENT INSWING

1. SIZE LIMITATIONS: (Based on AW-65 Designation)*

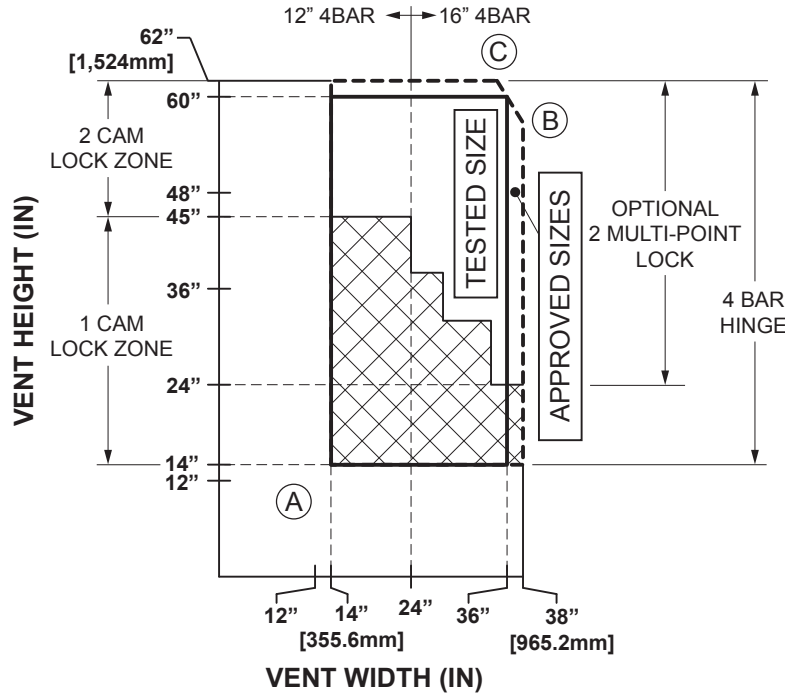

	VENT WIDTH	VENT HEIGHT
(A) MINIMUM SIZE	14" [355.6mm]	14" [355.6mm]
(B) MAXIMUM SIZE	38" [965.2mm]	56-3/4" [1,441.5mm]
(C) MAXIMUM SIZE	34-3/4" [882.7mm]	62" [1,574.8mm]
ONE CAM LOCK LIMITS		
	24" [609.6mm]	45" [1,143mm]
	28" [711.2mm]	38" [965.2mm]
	34" [863.6mm]	32" [812.8mm]
	38" [965.2mm]	24" [609.6mm]

MAXIMUM SQUARE FOOTAGE
FOR ±65 PSF = 15 SQ. FT.

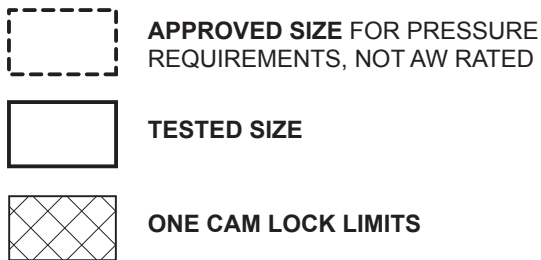

2. FOUR BAR HINGE USAGE

PART NO.	LENGTH	VENT WIDTH	MAX. WEIGHT	MAX. OPENING ANGLE
4K-14207	12"	≤ 24" [609.6mm]	83 lbs [38.0kg]	90°
4K-14208	16"	> 24" [609.6mm]	117 lbs [53.0kg]	90°

ACCESSIBLE WINDOW CASEMENT INSWING

1. SIZE LIMITATIONS: (Based on DP-45 Designation. Meets AAMA 513-44 Forces and Motion for Windows in Accessible Spaces)

VENT WIDTH	VENT HEIGHT	VENT AREA	ALLOWABLE DESIGN PRESSURE
MINIMUM SIZE (BUTT HINGE ONLY)			
Ⓐ 14-1/8" [358.8mm]	17-1/4" [438.2mm]	1.7 sq. ft.	65 psf
MINIMUM SIZE (4-BAR HINGE ONLY)			
Ⓑ 16" [406.4mm]	17-1/4" [438.2mm]	1.9 sq. ft.	65 psf
APPROVED SIZES			
Ⓒ 35" [889.0mm]	59-1/4" [1505.0mm]	14.3 sq. ft.	65 psf
Ⓓ 36" [914.4mm]	63-1/8" [1603.4mm]	15.7 sq. ft.	60 psf
Ⓔ 37" [939.8mm]	67" [1701.8mm]	17.2 sq. ft.	55 psf
Ⓕ 37-1/2" [952.5mm]	71-1/4" [1809.8mm]	18.6 sq. ft.	50 psf
TESTED SIZE			
Ⓖ 38" [965.2mm]	76" [1930.4mm]	20.1 sq. ft.	45 psf
MAXIMUM SIZE			
* Ⓗ 37" [939.8mm]	78" [1981.2mm]	20.0 sq. ft.	45 psf

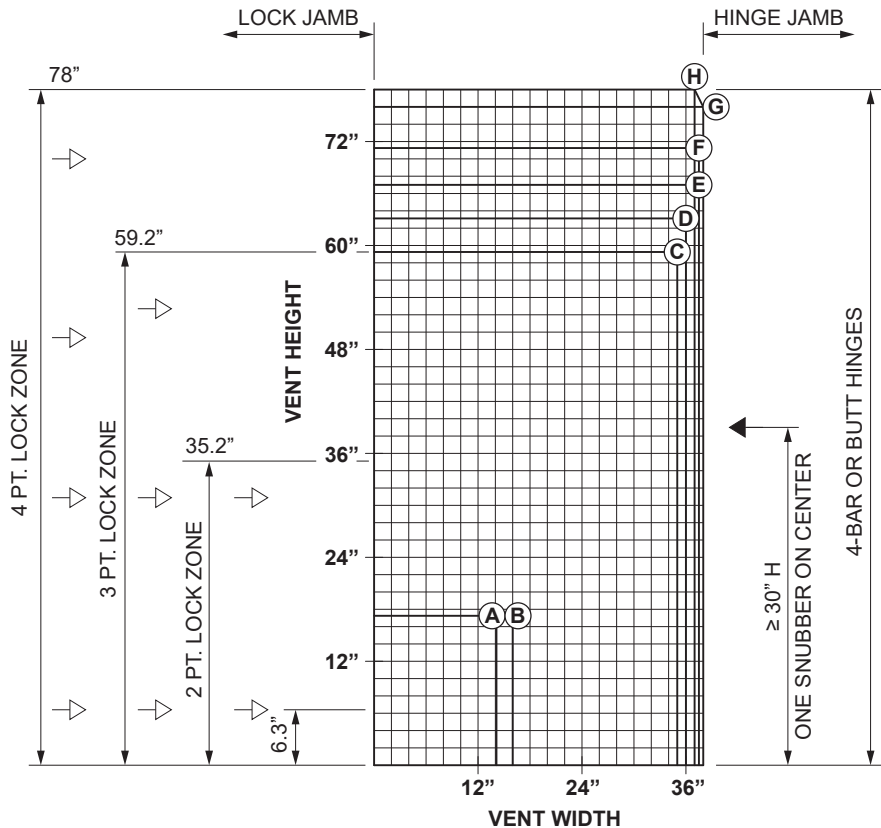

Note: NYC limit devices available for vents wider than 20".

* Approved size for pressure requirements, not AW rated.

CASEMENT OUTSWING

1. SIZE LIMITATIONS: (Based on AW-65 Designation)*

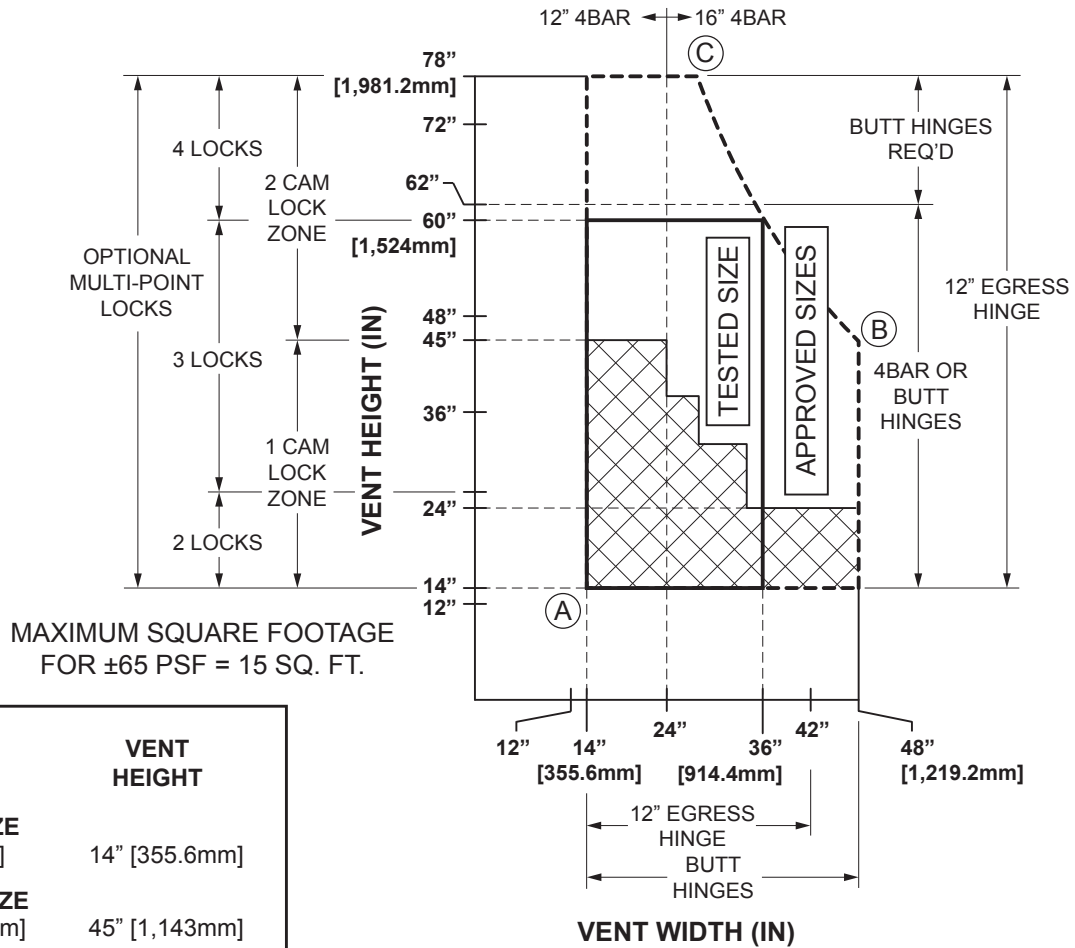

VENT WIDTH	VENT HEIGHT
(A) MINIMUM SIZE 14" [355.6mm]	14" [355.6mm]
(B) MAXIMUM SIZE 48" [1,219.2mm]	45" [1,143mm]
(C) MAXIMUM SIZE 27-5/8" [701.7mm]	78" [1,981.2mm]
ONE CAM LOCK LIMITS	
24" [609.6mm]	45" [1,143mm]
28" [711.2mm]	38" [965.2mm]
34" [863.6mm]	32" [812.8mm]
48" [1,219.2mm]	24" [609.6mm]

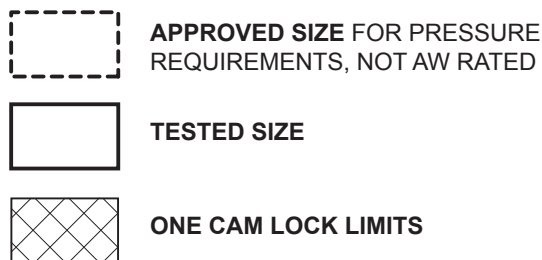

2. FOUR BAR HINGE USAGE

PART NO.	LENGTH	VENT WIDTH	MAX. WEIGHT	MAX. OPENING ANGLE
4K-14207	12"	≤ 24" [609.6mm]	83 lbs [38.0kg]	90°
4K-14208	16"	> 24" [609.6mm]	117 lbs [53.0kg]	90°
E1-1957	12" Egress	> 14" [355.6mm]	170 lbs [77.1kg]	90°

ACCESSIBLE WINDOW CASEMENT OUTSWING

1. SIZE LIMITATIONS: (Based on AW-65 & DP-45 Designation. Meets AAMA 513-14 Forces and Motion for Windows in Accessible Spaces.)

VENT WIDTH	VENT HEIGHT	VENT AREA	ALLOWABLE DESIGN PRESSURE
MINIMUM SIZE (BUTT HINGE ONLY)			
Ⓐ 14-1/8" [358.8mm]	17-1/4" [438.2mm]	1.7 sq. ft.	65 psf
MINIMUM SIZE (4-BAR HINGE ONLY)			
Ⓑ 25" [635.0mm]	17-1/4" [438.2mm]	3.0 sq. ft.	65 psf
APPROVED SIZES			
* Ⓓ 36" [914.4mm]	63-1/8" [1603.4mm]	15.7 sq. ft.	60 psf
* Ⓔ 37" [939.8mm]	67" [1701.8mm]	17.2 sq. ft.	55 psf
* Ⓕ 37-1/2" [952.5mm]	71-1/4" [1809.8mm]	18.6 sq. ft.	50 psf
TESTED SIZE			
Ⓒ 35" [889.0mm]	59" [1498.6mm]	14.3 sq. ft.	65 psf
Ⓖ 38" [965.2mm]	76" [1930.4mm]	20.1 sq. ft.	45 psf
MAXIMUM SIZE			
* Ⓗ 37" [939.8mm]	78" [1981.2mm]	20.0 sq. ft.	45 psf

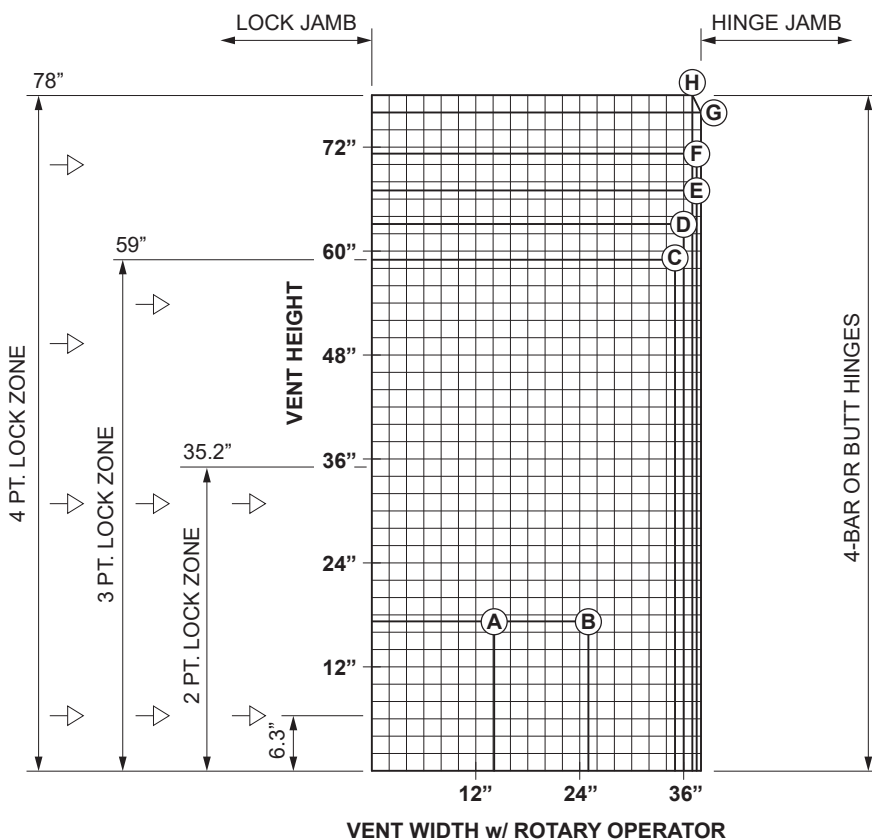

Notes: See Tech Drawings for vent size restrictions when using 4-Bar Hinges.

NYC limit devices available with butt hinges only

* Approved size for pressure requirements, not AW rated.

▷ LOCK POINT

PROJECT IN

1. SIZE LIMITATIONS: (Based on AW-65 Designation)*

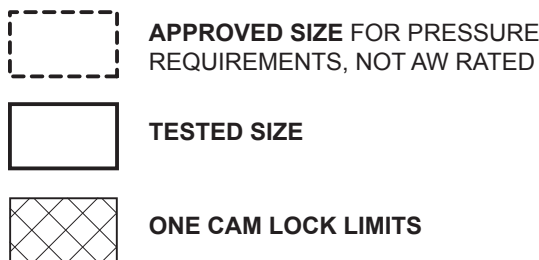
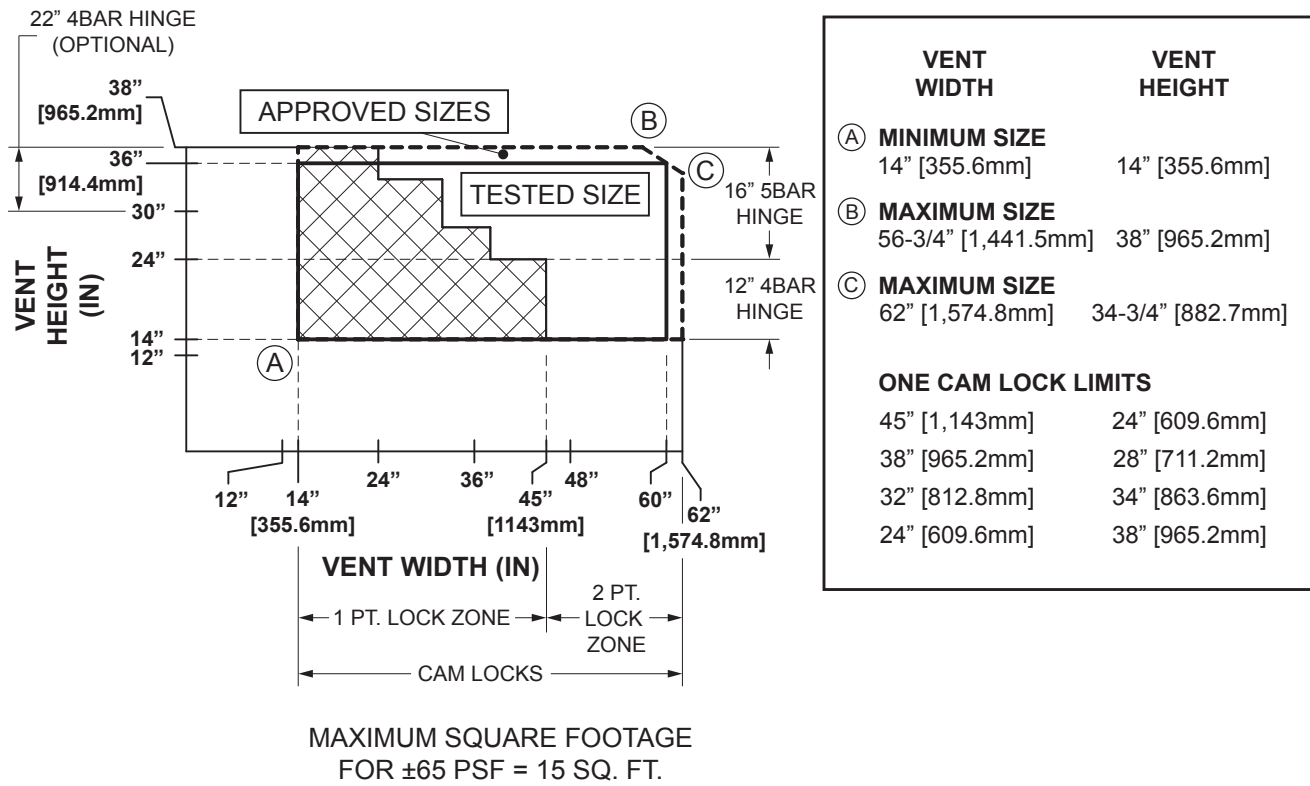

2. FOUR BAR HINGE USAGE

PART NO.	LENGTH	VENT HEIGHT	MAX. WEIGHT	MAX. OPENING ANGLE
4K-14207	12"	≤ 24" [609.6mm]	90 lbs [40.8kg]	20° w/ Limit Stop
5K-15284	16"	> 24" [609.6mm]	130 lbs [59.0kg]	30° w/o Limit Stop
4K-14209	22"	> 30" [762.0mm]	140 lbs [63.5kg]	45° w/ Limit Stop

PROJECT OUT

1. SIZE LIMITATIONS: (Based on AW-65 Designation)*

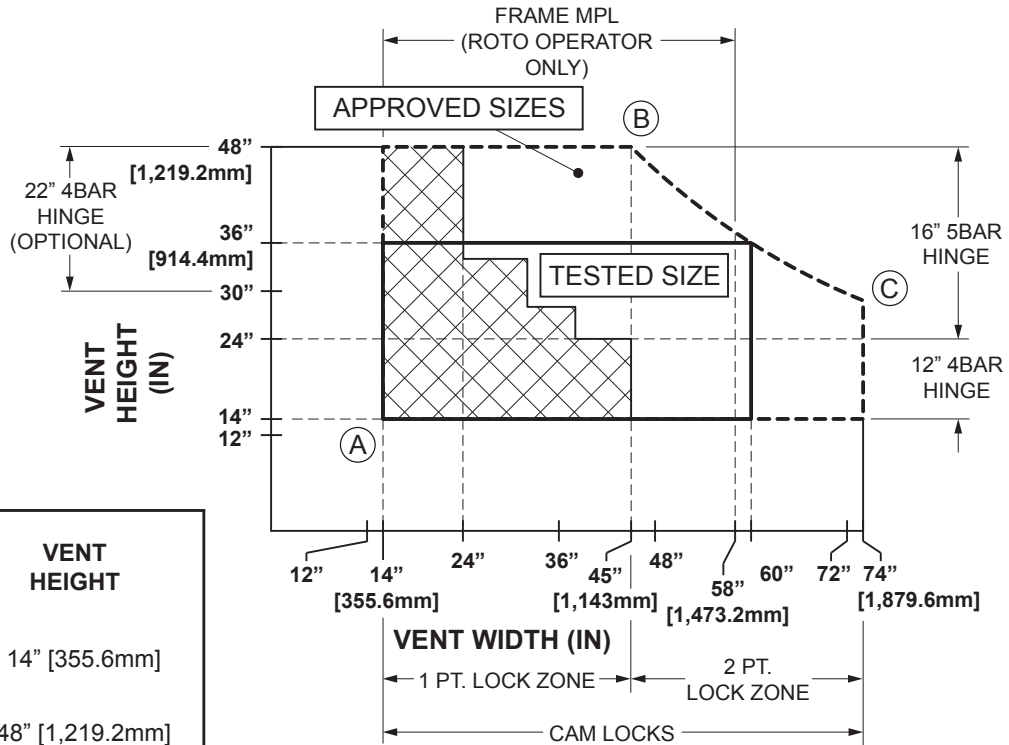

	VENT WIDTH	VENT HEIGHT
Ⓐ	MINIMUM SIZE 14" [355.6mm]	14" [355.6mm]
Ⓑ	MAXIMUM SIZE 45" [1,143mm]	48" [1,219.2mm]
Ⓒ	MAXIMUM SIZE 74" [1,879.6mm]	29-3/16" [741.4mm]
ONE CAM LOCK LIMITS		
	45" [1,143mm]	24" [609.6mm]
	38" [965.2mm]	28" [711.2mm]
	32" [812.8mm]	34" [863.6mm]
	24" [609.6mm]	48" [1,219.2mm]

MAXIMUM SQUARE FOOTAGE
FOR ±65 PSF = 15 SQ. FT.

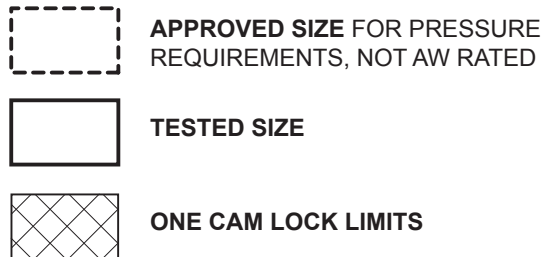

2. FOUR BAR HINGE USAGE

PART NO.	LENGTH	VENT HEIGHT	MAX. WEIGHT	MAX. OPENING ANGLE
4K-14207	12"	≤ 24" [609.6mm]	90 lbs [40.8kg]	20° w/ Limit Stop
5K-15284	16"	> 24" [609.6mm]	130 lbs [59.0kg]	30° w/o Limit Stop
4K-14209	22"	> 30" [762.0mm]	140 lbs [63.5kg]	45° w/ Limit Stop

ACCESSIBLE WINDOW PROJECT OUT

- 1. SIZE LIMITATIONS:** (Based on AW-45 Rating, Oversize 22.7 sq.ft. max.)
(AW-65 Rating 15 sq.ft. max.)
Meets AAMA 513-14 Forces and Motion for Windows in Accessible Places.)

VENT WIDTH	VENT HEIGHT	VENT AREA	ALLOWABLE DESIGN PRESSURE	VENT WEIGHT @ 7.2 lbs PER SQ. FT.
MINIMUM SIZE				
Ⓐ 23" [584.2mm]	25" [635.0mm]	4.0 sq. ft.	65 psf	28.8 lbs
Ⓑ 30" [762.0mm]	48" [1219.2mm]	10.0 sq. ft.	65 psf	72.0 lbs
Ⓒ 36" [914.4mm]	60" [1524.0mm]	15.0 sq. ft.	65 psf	108.0 lbs
Ⓓ 39" [990.6mm]	69" [1752.6mm]	18.7 sq. ft.	55 psf	134.6 lbs
MAXIMUM TESTED SIZE				
Ⓔ 42" [1066.8mm]	78" [1981.2mm]	22.7 sq. ft.	45 psf	163.4 lbs.

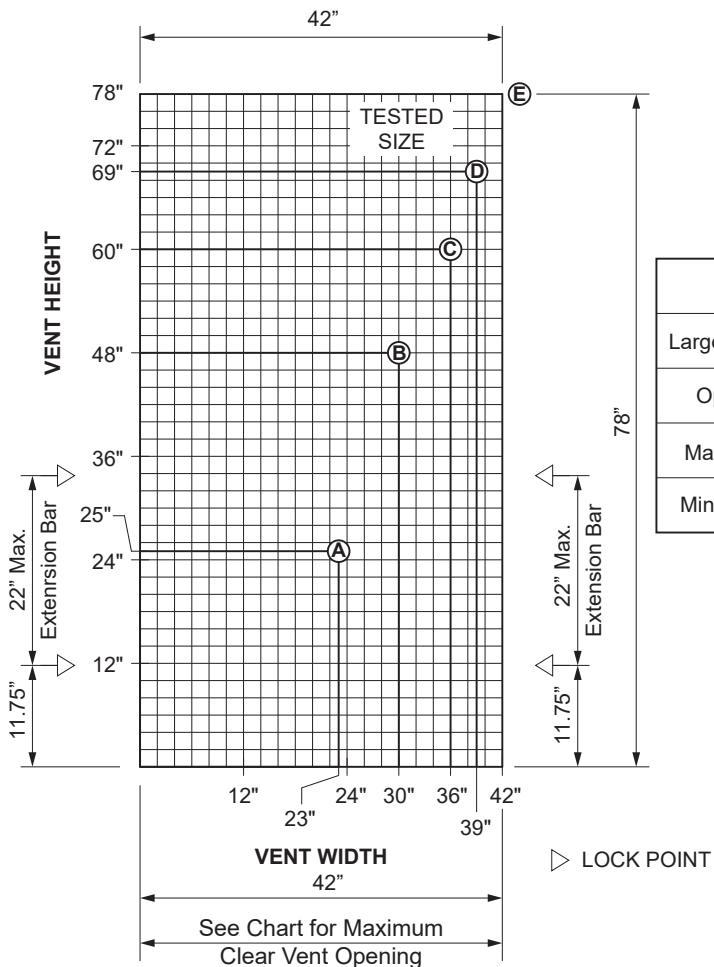

Operator Part #	*E1-1991	*E1-2012	E1-2013	E1-1992
Large Handle Crank Part #	E1-1983	E1-1983	E1-1983	E1-1983
Operator Arm Length	5-1/2"	7"	9"	11"
Maximum Vent Opening	1-3/16"	2-11/16"	4-11/16"	6-11/16"
Minimum Vent Cut Width	23"	26"	30"	34"

* E1-1991 & E1-2012 rotary operators cannot be used in NYC, if NYC limit devices are used.

YOW 225 HARDWARE GUIDE

	DESCRIPTION	CASEMENT OUT	CASEMENT IN	PROJECT OUT	PROJECT IN
LOCKING HARDWARE	CAM HANDLES	STANDARD	STANDARD	STANDARD	STANDARD
	CUSTODIAL CAM LOCK (HEX KEY)	OPTIONAL	OPTIONAL	OPTIONAL	OPTIONAL
	MULTI-LOCK HANDLE	OPTIONAL	OPTIONAL	OPTIONAL	
	CUSTODIAL MULTI-LOCK (HEX KEY)	OPTIONAL	OPTIONAL	OPTIONAL	
	POLE RING LOCKS	OPTIONAL	OPTIONAL	OPTIONAL	OPTIONAL
HINGE & LIMIT STOP HARDWARE	4 BAR HINGES	STANDARD	STANDARD	STANDARD	STANDARD
	BUTT HINGES	OPTIONAL	OPTIONAL		
	FRICTION ADJUSTERS	STANDARD W/ BUTT HINGES	STANDARD W/ BUTT HINGES		
	ROTO-OPERATOR	OPTIONAL W/ BUTT HINGES		OPTIONAL	
	4-BAR EGRESS HINGES	OPTIONAL			
	LIMIT STOP IN 4-BAR HINGE ONLY	OPTIONAL	OPTIONAL	OPTIONAL	OPTIONAL
	KEYED LIMIT DEVICE	OPTIONAL	OPTIONAL	OPTIONAL	OPTIONAL
	4" LIMIT DEVICE (APPROVED FOR NEW YORK CITY)	OPTIONAL		OPTIONAL	
	SCREENS	OPTIONAL	OPTIONAL	OPTIONAL	OPTIONAL

ACCESSIBLE WINDOW HARDWARE GUIDE

	DESCRIPTION	CASEMENT IN 4-BAR HINGE	CASEMENT IN BUTT HINGE	CASEMENT OUT 4-BAR HINGE	CASEMENT OUT BUTT HINGE	PROJECT OUT
LOCKING HARDWARE	FMPL W/ STANDARD 4" HANDLE			STANDARD	STANDARD	STANDARD
	FMPL W/ EXTENDED 8" HANDLE			OPTIONAL	OPTIONAL	OPTIONAL
	VMPL W/ EXTENDED HANDLE	STANDARD	STANDARD			
	LOCK BAR BASE	STANDARD	STANDARD	STANDARD	STANDARD	STANDARD
	LOCK BAR EXTENSION	STANDARD	STANDARD	STANDARD	STANDARD	STANDARD
	KEEPER	STANDARD	STANDARD	STANDARD	STANDARD	STANDARD
HINGE & LIMIT STOP HARDWARE	SINGLE ARM OPERATOR			STANDARD	STANDARD	
	DUAL ARM OPERATOR					STANDARD
	LARGE HANDLE CRANK			STANDARD	STANDARD	STANDARD
	LOOSE RIVET 4-BAR HINGE					STANDARD
	12" 4-BAR HINGE	STANDARD		STANDARD		
	BUTT HINGE		STANDARD		STANDARD	
	NYC FALL PREVENTION LIMIT DEVICE *	OPTIONAL	OPTIONAL		OPTIONAL	OPTIONAL
	GUIDE ROLLER	STANDARD		STANDARD		
	SCREENS	OPTIONAL	OPTIONAL	OPTIONAL	OPTIONAL	OPTIONAL

* Refer to Tech Drawings for more information.