



TABLE OF CONTENTS

**YCN 40 T THERMAL STOREFRONT CAN SYSTEM
FOR 1" GLAZING
2" x 4-3/8"**

YCN 40 T PICTORIAL VIEW..... Page 2

YCN 40 T DOOR FRAMING MEMBERS (1/4 SIZE)..... Pages 3 & 4

WIND LOAD / DEAD LOAD CHARTS..... Pages 5 & 6

*The latest installation instructions for this product are available at www.ykkap.com.

YCN 40 T STOREFRONT SYSTEM PICTORIAL VIEW

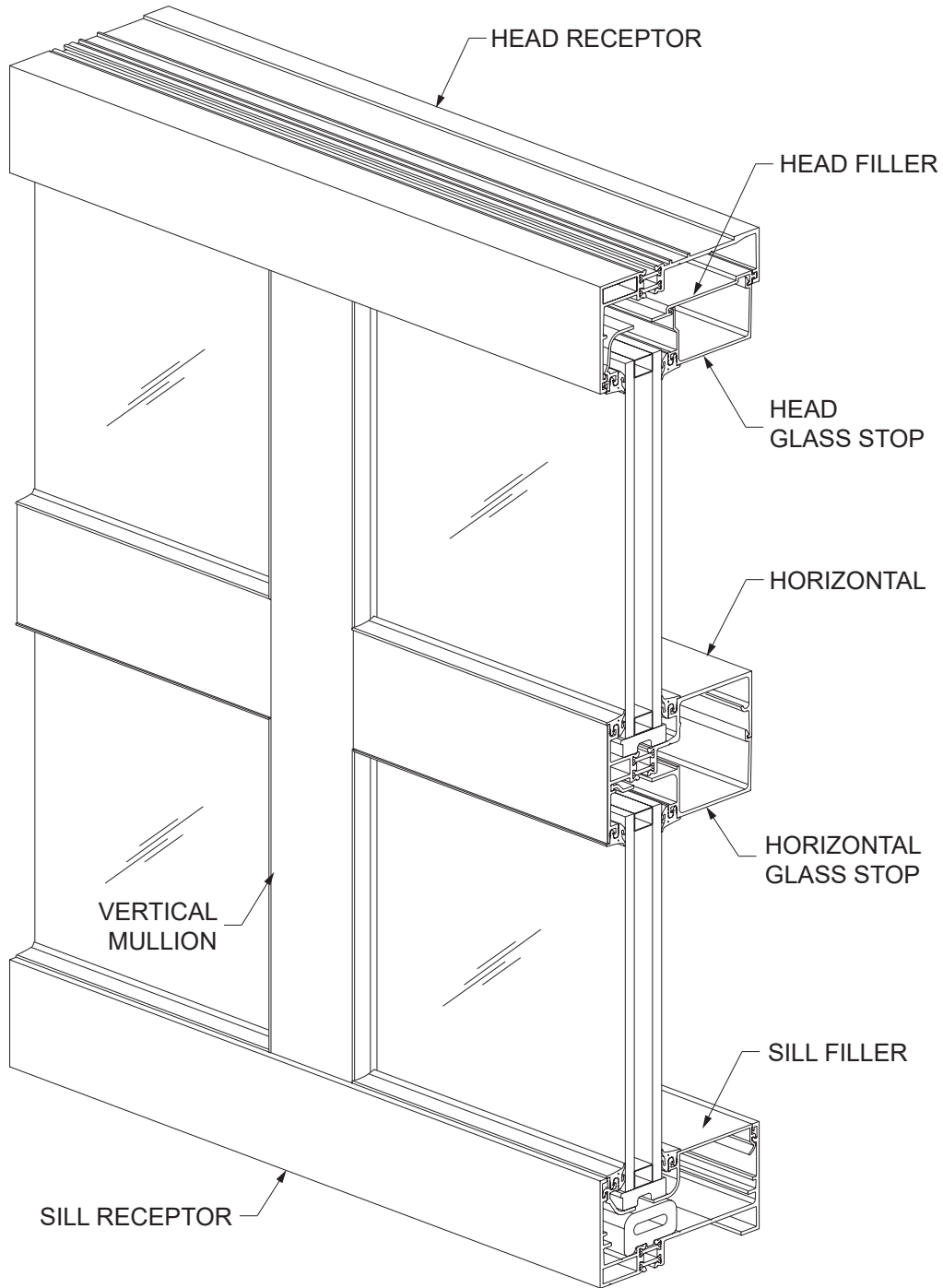

YCN 40 T FRAMING MEMBERS FOR OUTSIDE GLAZING

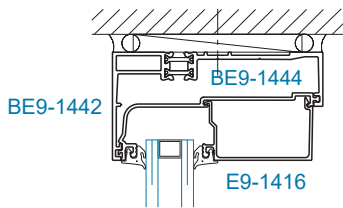
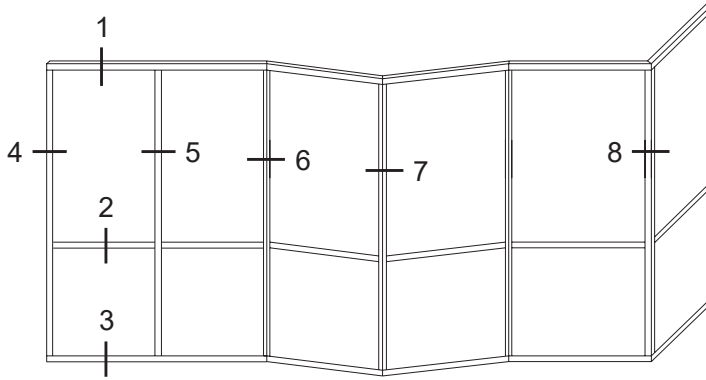

SECTION 1
HEAD

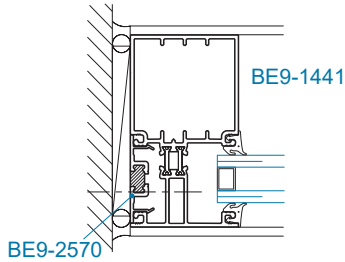

SECTION 4
JAMB

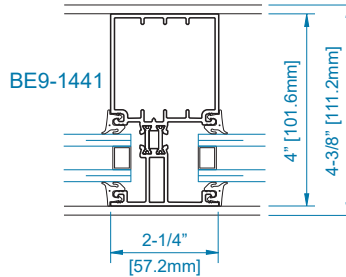

SECTION 5
VERTICAL

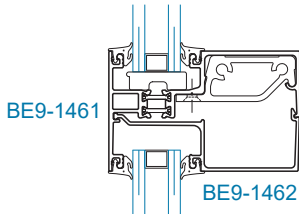

SECTION 2
HORIZONTAL

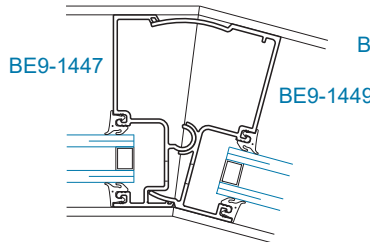

SECTION 6
OUTSIDE HINGED
MULLION (4°-22.5°)

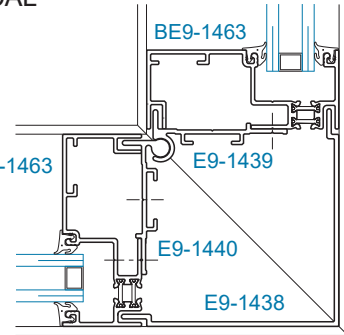

SECTION 8
90° OUTSIDE CORNER

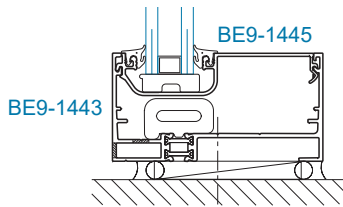

SECTION 3
SILL

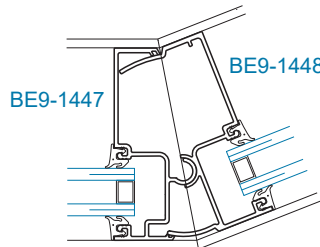

SECTION 7
OUTSIDE HINGED
MULLION (4°-22.5°)

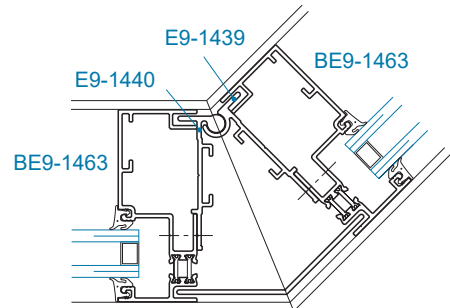

SECTION 7A
135° OUTSIDE CORNER

SCALE: 1/4 SIZE

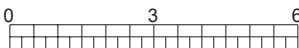

YCN 40 T DOOR T FRAMING MEMBERS

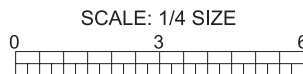
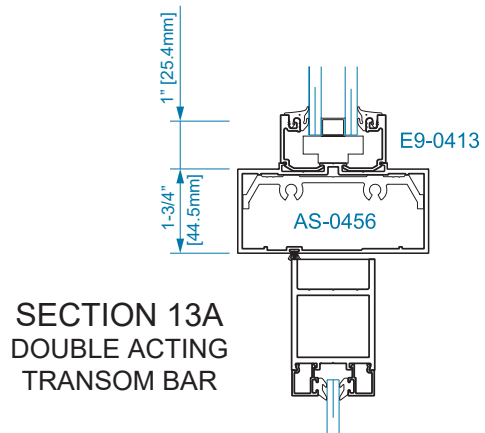
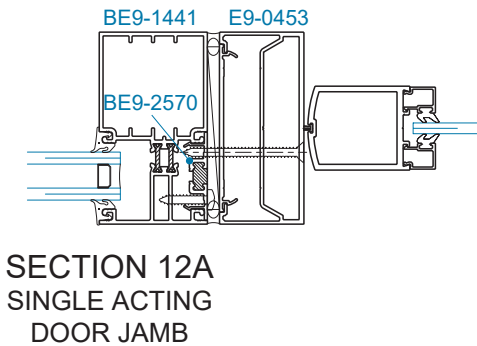
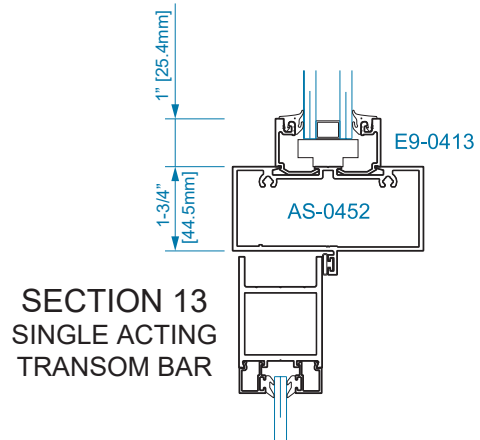
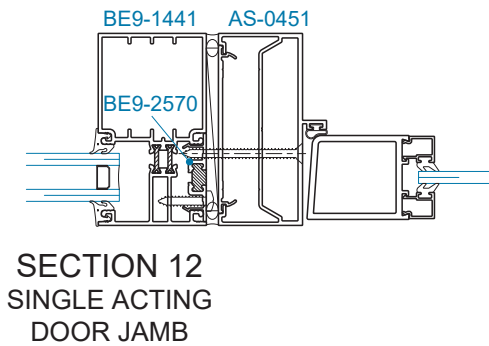
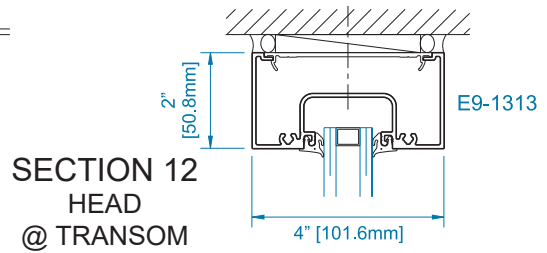
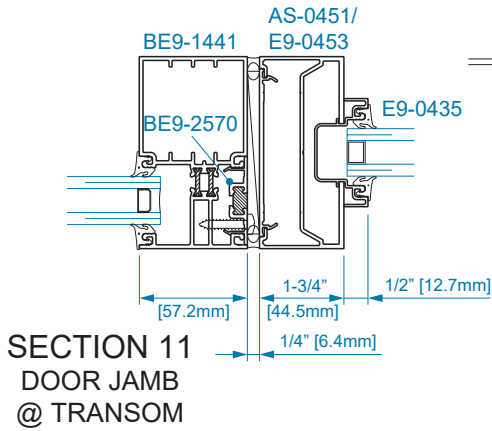
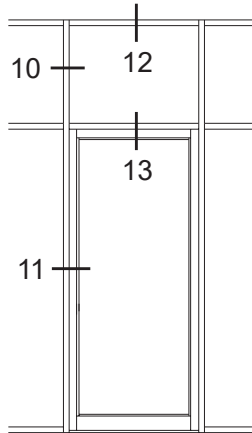

YCN 40 T WIND LOAD CHARTS

DEFLECTION CRITERIA: AAMA TIR-A11 - L/175 or

L/240 + 1/4" (6.4mm) - FOR SPANS GREATER THAN 13'-6" (4.1m) BUT LESS THAN 40'-0" (12.2m)

CODES AND SPECIFICATIONS MAY VARY, NO SINGLE LITE OF GLASS SHALL DEFLECT MORE THAN 3/4" (19.1mm)

ALLOWABLE WIND LOAD STRESS

YKK AP tested standard. Contact YKK AP for more information.

These charts include unbraced length analysis and are based off at least one horizontal being placed at the midpoint of the span. For other applications, please contact YKK AP engineers at 1-866-955-2732.

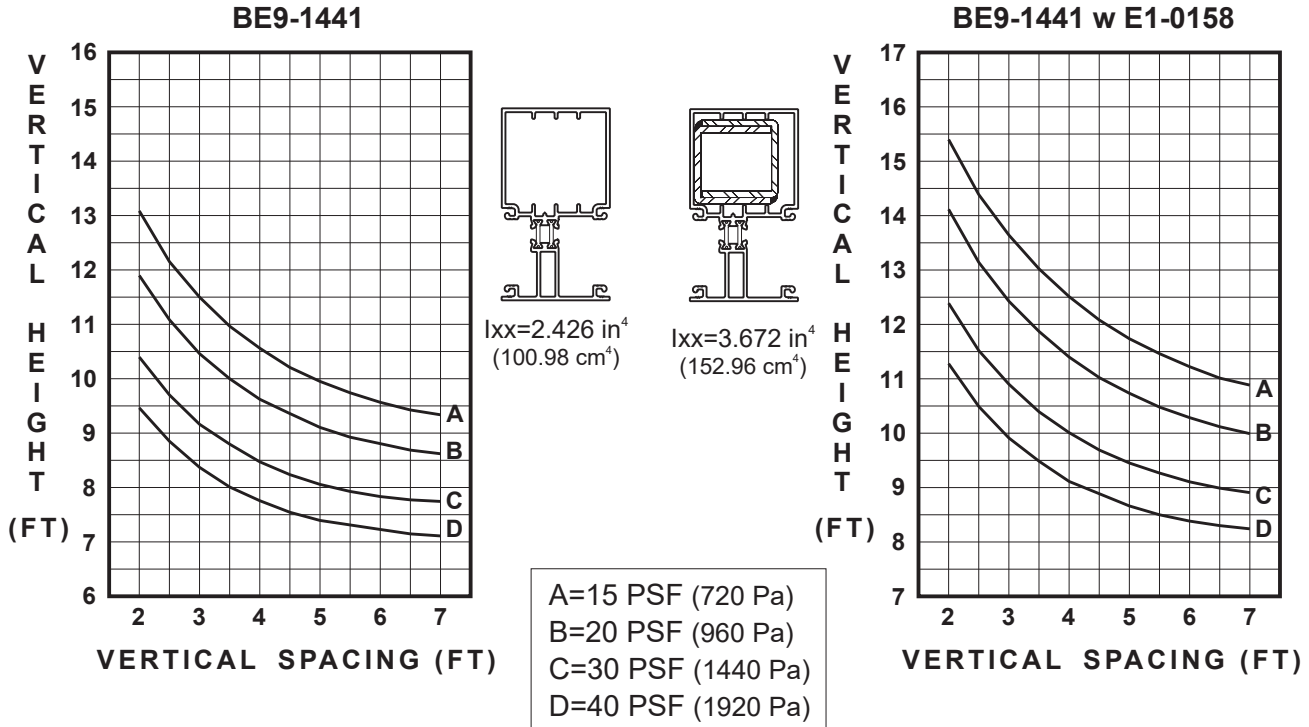

YCN 40/40 T DEAD LOAD CHARTS

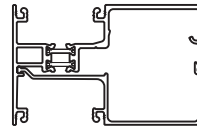

A = SETTING BLOCKS AT 1/8 POINT LOCATIONS
 B = SETTING BLOCKS AT 1/4 POINT LOCATIONS

Note: Dead Load requirements are based upon a maximum deflection of 1/8" (3.2mm) at the center of the horizontal.

