

YES 45 XT High Performance Thermal Storefront System

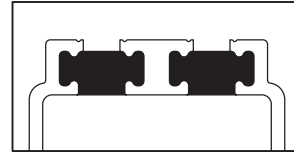

Dual Thermal Barrier



ThermaBond Plus® Pour & Debridge Technology

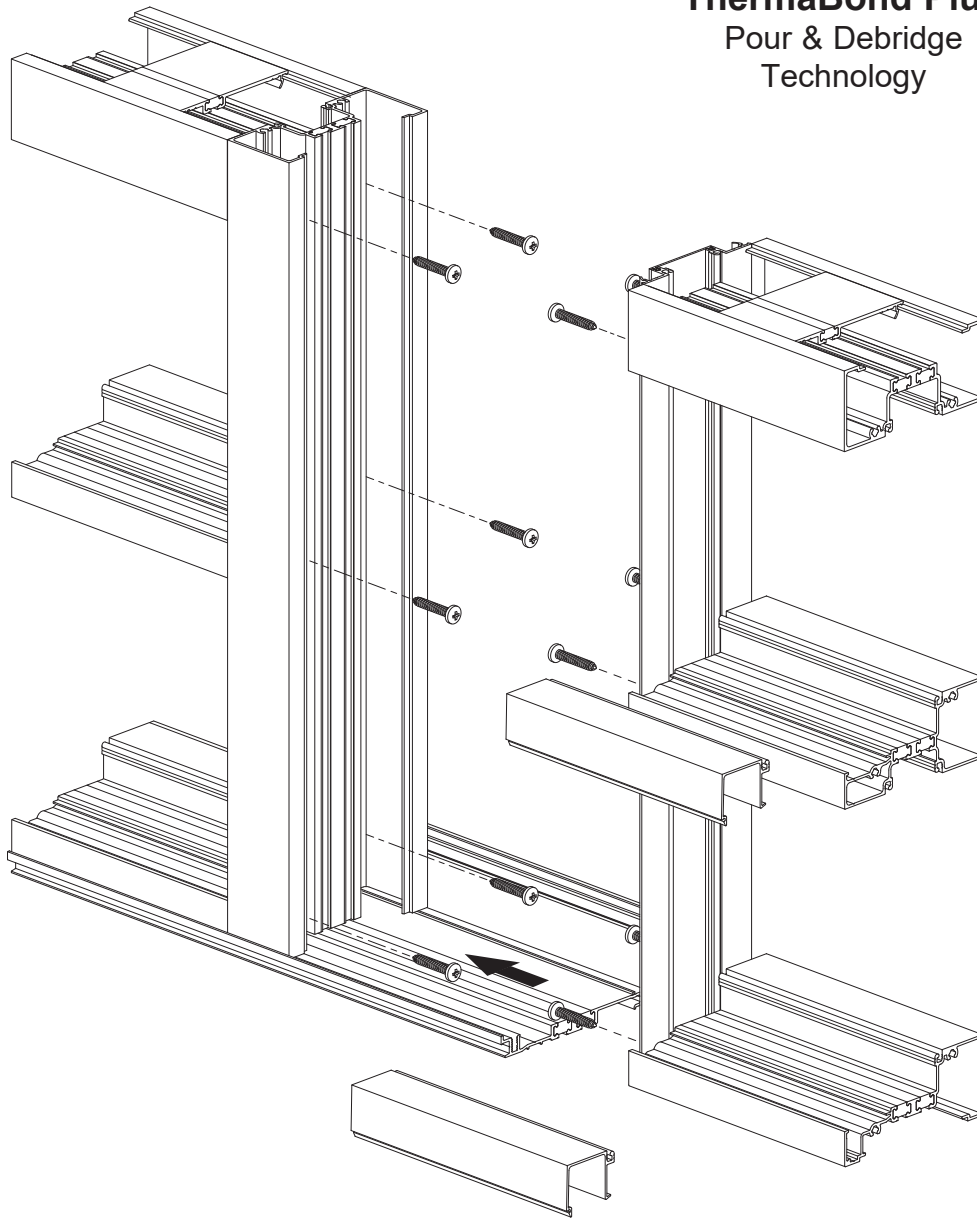

Installation Manual

TABLE OF CONTENTS

Installation Notes	Page ii
PARTS DESCRIPTION	
YES 45 XT Framing Members	Pages 1 & 2
YES 45 XT Door Framing Members	Pages 2 & 3
YES 45 XT Accessories	Page 4
FRAME FABRICATION	
Determine Frame Size.....	Page 5 & 6
Fabricate Two Piece Verticals.....	Pages 7 & 8
Fabricate Head, Horizontal & Sill Members	Page 9
Fabricate Glass Stops & Glazing Adaptors.....	Page 9
Fabricate Sill Members.....	Page 9
Fabricate Sill Flashing	Pages 10 & 11
Fabricate Head Receptor	Page 11
FRAME ASSEMBLY	
Assemble Frames For Screw Spine Assembly	Page 12
Install Mullion End Cap (Optional).....	Page 13
FRAME INSTALLATION	
Install Sill Flashing End Dams.....	Page 14
Install Sill Flashing.....	Page 15
Install Sill Flashing Splice Sleeve.....	Page 15 to 16
Attach Head Receptor End Caps	Page 17
Install Head Receptor.....	Page 18
Fabricate/Install Sill Flashing for Corners.....	Page 19
Prepare Door Jambs	Page 20
Install Frames	Page 21 & 22
Install Expansion Mullions where Required.....	Page 23
Install Corner Assemblies.....	Page 24
Install Optional Compound Mullions.....	Pages 25 & 26
Apply Perimeter Sealant.....	Pages 27 & 28
Install Water Deflectors	Page 29
Apply Internal Sealant	Page 30
Install Glazing Adaptors.....	Page 30
Install Optional Compound Horizontals	Pages 31 to 33
GLAZING	
Install Interior Glazing Gaskets	Page 34
Install Glass	Page 35
Install Anti-Walk Blocks	Page 36
Install Exterior Glass Stops & Gaskets	Pages 36 & 37

Installation Notes

1. Do not drop, roll or drag boxes of aluminum framing. Move and stack boxes with proper support to prevent distortion. If fork lifts are used be especially careful about striking the boxes when lifting or moving.
2. Store in a dry, out of the way area. If rain exposure, condensation or any water contact is likely, then all packaging material should be removed. Wet packaging materials will discolor and may stain aluminum finishes and paints.
3. All materials should be checked for quality and quantity upon receipt, YKK AP must be notified immediately of any discrepancies in shipment. Check to make sure that you have the required shims, sealants, supplies and tools necessary for the installation.
4. Carefully check the openings and surrounding conditions that will receive your material. Remember, if the construction is not per the construction documents, it is your responsibility to notify the general contractor in writing. Any discrepancies must be brought to the general contractor's attention before you proceed with the installation.
5. Gather your shop drawings, materials, packing list, and this installation manual. Carefully review parts location, the sequence it goes therein, when you glaze it and how you seal it. Installation instructions are of a general nature and may not cover every condition you will encounter. The shop drawings and/or installation manuals were prepared specifically for the product.
6. Any material substitutions must be of equal or greater quality.
7. Make certain that material samples have been sent for compatibility testing for all manufacturer's sealants involved. Make certain sealants have been installed in strict accordance with the manufacturer's recommendations and specifications.
8. Remember to isolate, in an approved manner, all aluminum from uncured masonry or other incompatible materials.
9. System-to-structure fasteners are not supplied by YKK AP. Fasteners called out on shop drawings are to indicate minimum sizes for design loading.
10. Entrances are to be installed plumb, square, level and true.
11. Please contact the YKK AP DirecTech application engineering department for any project specific condition not covered by these instructions.
12. YKK AP storefront and/or curtain wall framing is typically completed before drywall, flooring and other products which may still be in process. Take the extra time to wrap and protect the installed material.
13. Cutting tolerances are plus zero (0"), minus one thirty second (-1/32") unless otherwise noted.
14. Check our website, www.ykkap.com, for the latest installation manual update prior to commencing work.

YES 45 XT FRAMING MEMBERS (2" x 4-1/2")

	Vertical / Jamb	BE9-2601		Expansion Mullion (Male)	BE9-2608
	Head - Outside Glazing	BE9-2602		Hinged Mullion (Male)	BE9-2557
	Horizontal	BE9-2603		Hinged Mullion (Female)	BE9-2558
	Sill - Inside & Outside Glazing Head - Inside Glazing	BE9-2604		90° Corner Mullion	BE9-2566
	Glass Stop	E9-1015		90° Corner Mullion	BE9-2567
	Sill Flashing	BE9-2620		3-Way Corner Mullion	BE9-2568
	Heavy Duty Vertical Mullion	BE9-2606		135° Corner Mullion	BE9-2569
	Pocket Filler	BE9-2605		4-1/2" Horizontal/Sill	BE9-1513
	Head Receptor	BE9-2562		Glazing Adaptor For 1/2", 5/8" & 3/4" glazing	E9-1039
	Head Receptor Stop	E9-1033		Glazing Adaptor For 1/4" glazing	E9-1040
	Deep Pocket Filler	BE9-2609		Adaptor for High Sill	BY7-9478
	Expansion Mullion (Female)	BE9-2607		2-1/2" x 3/4" Face Cover * For Custom Mullions and Horizontals	E9-1206

* Other sizes available. Contact YKK AP for more information.

YES 45 XT FRAMING MEMBERS (2" x 4-1/2", Continued)

	5" x 3/4" Face Cover * For Custom Mullions and Horizontals	E9-3542		
--	--	----------------	--	--

THERMAL DOOR FRAMING MEMBERS FOR 25T/35T/50T











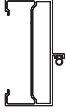

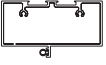

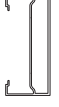
	Single Acting Door Jamb Elastomer Weathering E2-0051 Not Included	BE9-2581		Transom Glazing Pocket For 1" Glazing	BE9-2583
	Deep Pocket Filler	BE9-2609		Snap-in Pocket Filler	BE9-2571
	Transom Bar Elastomer Weathering E2-0051 Not Included	BE9-2582		Threshold 1/2" x 4-1/2"	BE9-0465
	Transom Glass Stop For 1" Glazing	E9-1592			

THERMAL DOOR FRAMING MEMBERS FOR 35XT/50XT *











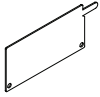





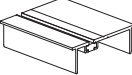

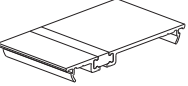

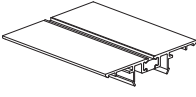

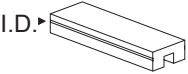

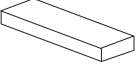

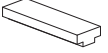
	Single Acting Door Jamb E2-0051 Not Included	BE9-1530		Transom Glass Stop For 1" glazing	E9-1592
	Single Acting Door Head/Transom Bar E2-0051 & E2-0062 Not Included	BE9-1532		Transom Glazing Pocket For 1" glazing	BE9-1591
	Threshold 1/2" x 4-1/2"	BE9-1535			

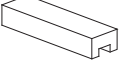
* Note: 35XT and 50XT Doors and frames to be discontinued as of May 1st, 2024.

NON-THERMAL DOOR FRAMING MEMBERS

	Single Acting Door Jamb Elastomer weathering E2-0051 included	AS-0411		Door Stop Base Elastomer weathering E2-0051 included Used with AS-0409	E9-1113
	Single Acting Door Head/Transom Bar Elastomer weathering E2-0051 included	AS-0412		Transom Glass Stop For 1/4" glazing	E9-0403
	Double Acting Door Jamb	E9-0415		Transom Glass Stop For 1" glazing	E9-0413
	Double Acting Door Head/Transom Bar Pile weathering E2-0062 included	AS-0426		Transom Glazing Pocket For 1/4" glazing	E9-0434
	Intermediate Door Jamb 2" x 4-1/2" Tube Use with AS-0409	E9-9312		Transom Glazing Pocket For 1" glazing	E9-0435
	Deep Pocket Filler Use with door jambs	E9-1019		Sash Base Use with E9-0403 or E9-0413 glass stops	E9-0408
	Door Stop O/P Assembly Elastomer weathering E2-0051 included Used with E9-1113	AS-0409		Threshold 1/2" x 4"	E9-0407

YES 45 XT ACCESSORIES

	End Dam For Sill Flashing BE9-2620	E1-0199		Pile Weathering Seal	E2-0062
	End Cap For Head Receptor BE9-2562	E1-2603		Glazing Gasket	E2-0052
	Splice Sleeve For Sill Flashing BE9-2620 and Head Receptor BE9-2562	E2-0070		Glazing Gasket	E2-0053
	Head Anchor 4" Long	E1-2602		Glazing Gasket	E2-0064
	Flat Filler Use at all anchor locations	E1-2601		Elastomer Weathering For Head Receptor & Door Frame	E2-0051
	Sidelite Base Clip For compound horizontals, 4" Long	E1-9836		Weathering Gasket For Expansion Mullion	K2-2441
 I.D. ▶	Setting Block For Outside Glazed Horizontal	E2-0068		Foam Backer Tape 1" x 1-1/4" (Roll)	E2-0259
	Setting Block For Inside Glazed Intermediate Horizontal	E2-0611		#10-24 x 1/2" PHMS Stainless Steel For Attachment of Sill to Sill Flashing	PM-1008 -SS
	Setting Block For 1" Glazing of Transom Head	E2-0056		#10-24 x 7/16" PHMS Stainless Steel For Attachment of 4-1/2" Sill to Sill Flashing	PM-1007 -SS
	Setting Block For 4-1/2" Horizontal	E2-0628		#12 x 3/4" UFHSMS Type A, Zinc Plated Steel For End Dam Attachmen	UA-1212
	Water Deflector	E2-0047		#12 x 1" PHSMS Type AB Zinc Plated Steel For Screw Spline Attachment	PC-1216
	"W" Side Block For Deep Pocket	E2-0153		#12 x 1-1/4" PHSMS Type AB Zinc Plated Steel, For Screw Spline Attachment when using BE9-2602 as Vertical	PC-1220
	PVC Flat Filler	E3-0023		#12 x 1/2" FHSMS Type AB, Zinc Plated Steel For Attachment of E1-2603 End Cap to Head Receptor	FC-1208

FRAME FABRICATION

STEP 1 DETERMINE FRAME SIZE

Determine Frame Width:

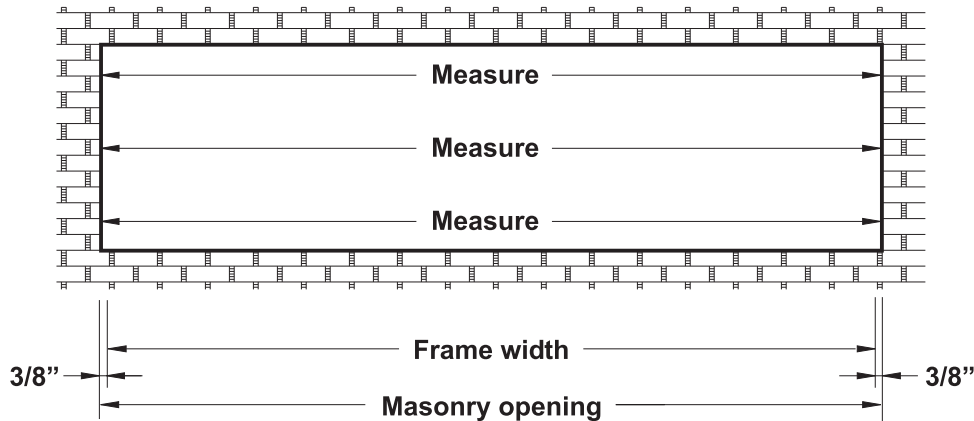

Note: Check the opening for squareness and plumb at both ends. Units must be installed in a true rectangle.

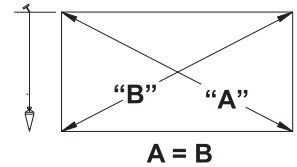

Detail 1

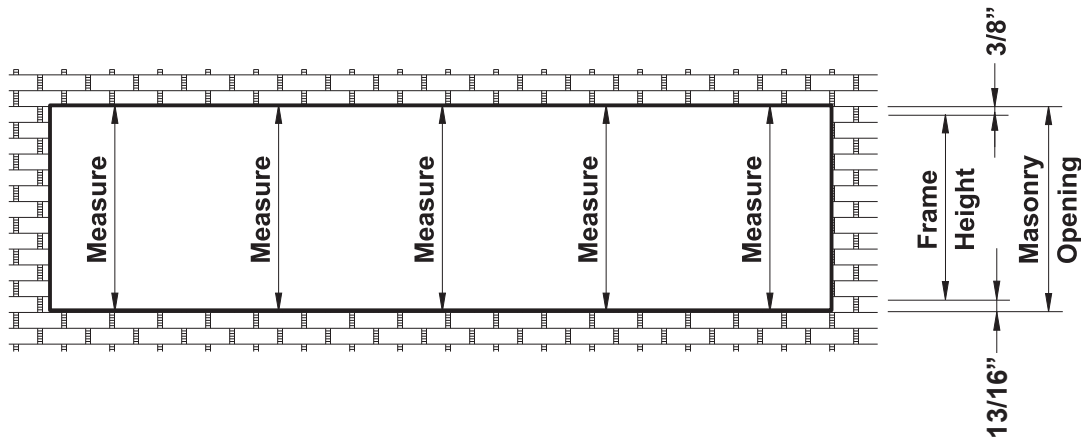

Detail 2

- Measure the height of the masonry opening in several places along the entire length of the opening.
- Select the smallest dimension measured and subtract 1-3/16" to determine the frame height to be used:
 - 3/8" shim/caulk joint at the head.
 - 7/16" for sill flashing.
 - 3/8" shim/caulk joint below the sill flashing.

See **Detail 2**.

FRAME FABRICATION

STEP 1 DETERMINE FRAME SIZE

Determine Frame Height for Receptor Conditions:

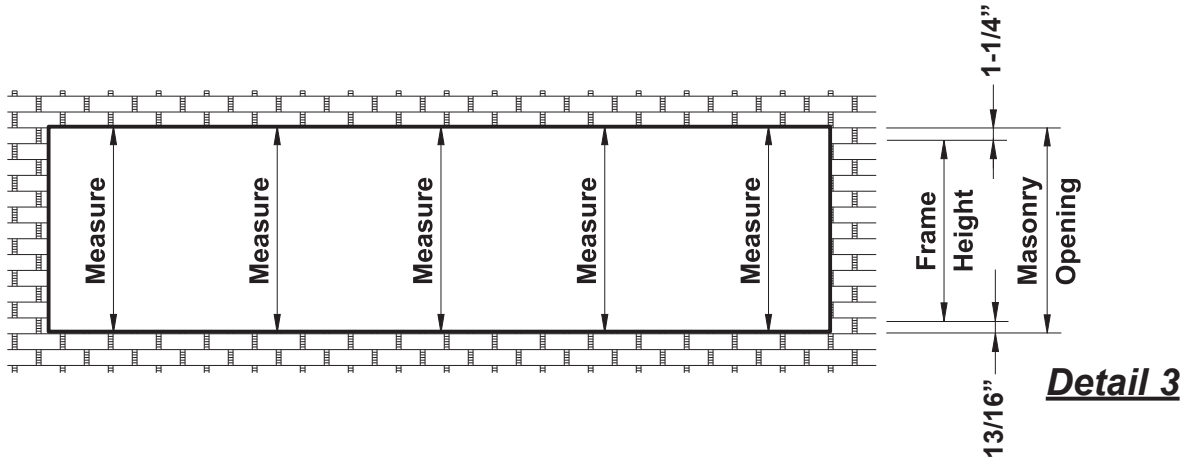

- Measure the height of the masonry opening in several places along the entire length of the opening.
- Select the smallest dimension measured and subtract 2-1/16" to determine the frame height to be used:
 - Minimum 3/8" shim/caulk joint at the head.
 - 7/8" for the head receptor
 - 7/16" for sill flashing.
 - Minimum 3/8" shim/caulk joint below the sill flashing.

See **Details 3 & 4**.

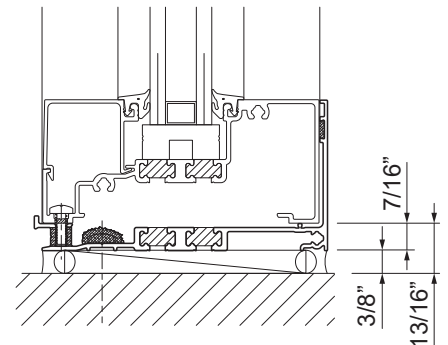
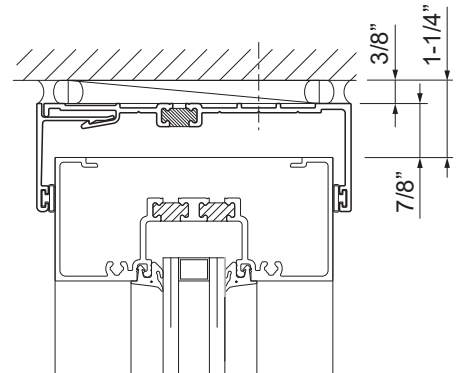

Detail 4

FRAME FABRICATION

STEP 2 FABRICATE TWO PIECE VERTICALS

-Cut the two piece vertical and jamb members to the frame height determined in Step 1.
-Fabricate holes in vertical members for screw spline attachment using one of the methods below:

1. Using a short piece of each horizontal member as a template, center the template on the face of the vertical and mark the location of each screw spline.
Drill a 0.236" diameter (#B drill bit) hole at each location marked.
2. Layout the hole locations as shown in **Detail 5** and drill a 0.236" dia. (#B drill bit) clearance hole at each location marked.
3. Use the YKK AP drill fixture, H-7201, to drill the holes.
4. Use punch press with appropriate die set.

Note: End reaction = $\frac{\text{Frame Height (ft)} \times \text{Mullion Spacing (ft)} \times \text{Wind Load (PSF)}}{2}$

or consult YKK AP DirecTech.

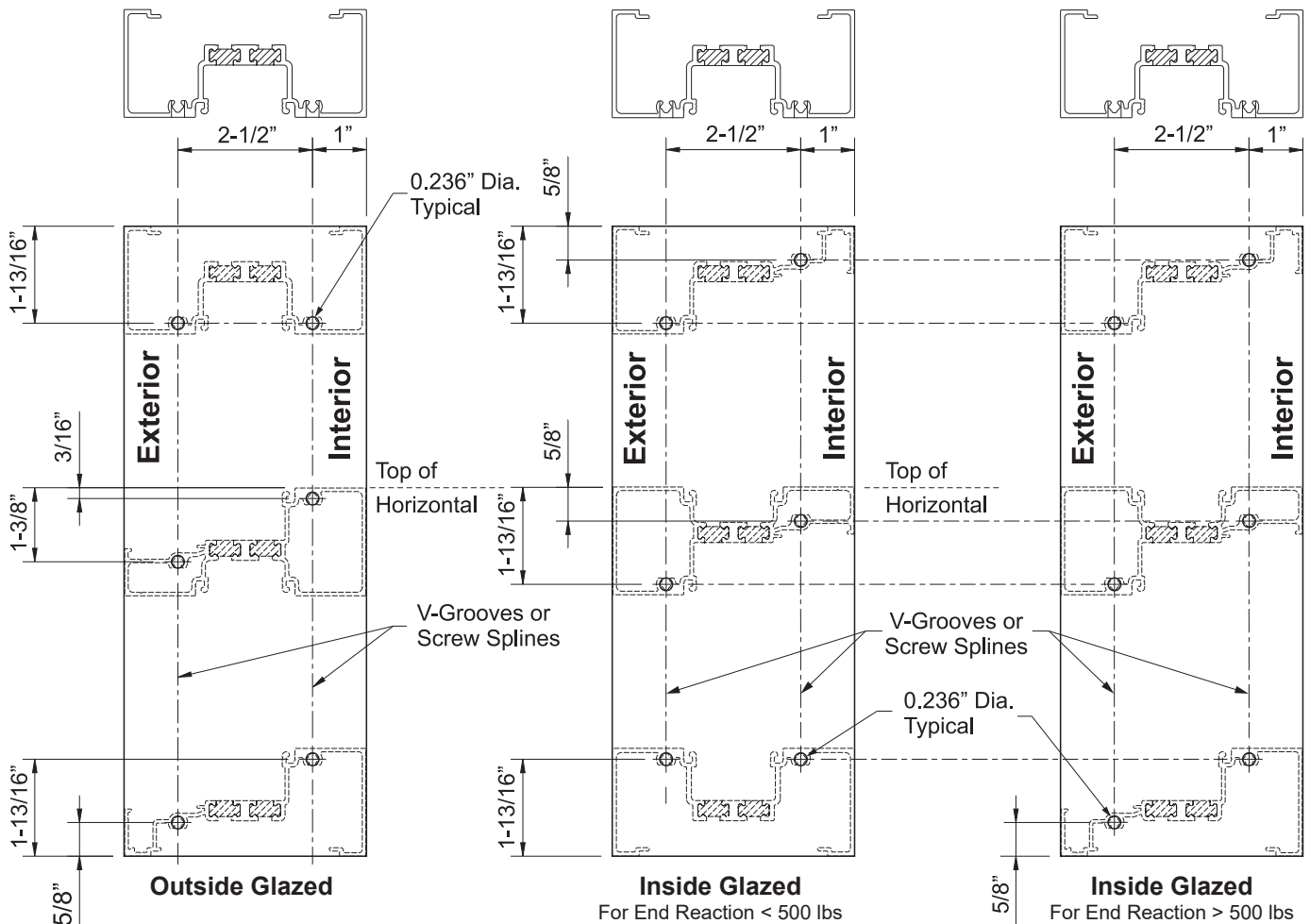

Detail 5

FRAME FABRICATION

STEP 2 (Continued)

FABRICATE TWO PIECE VERTICALS

-Fabrication of shallow pocket filler is similar to that of the mullions.

See **Detail 6**.

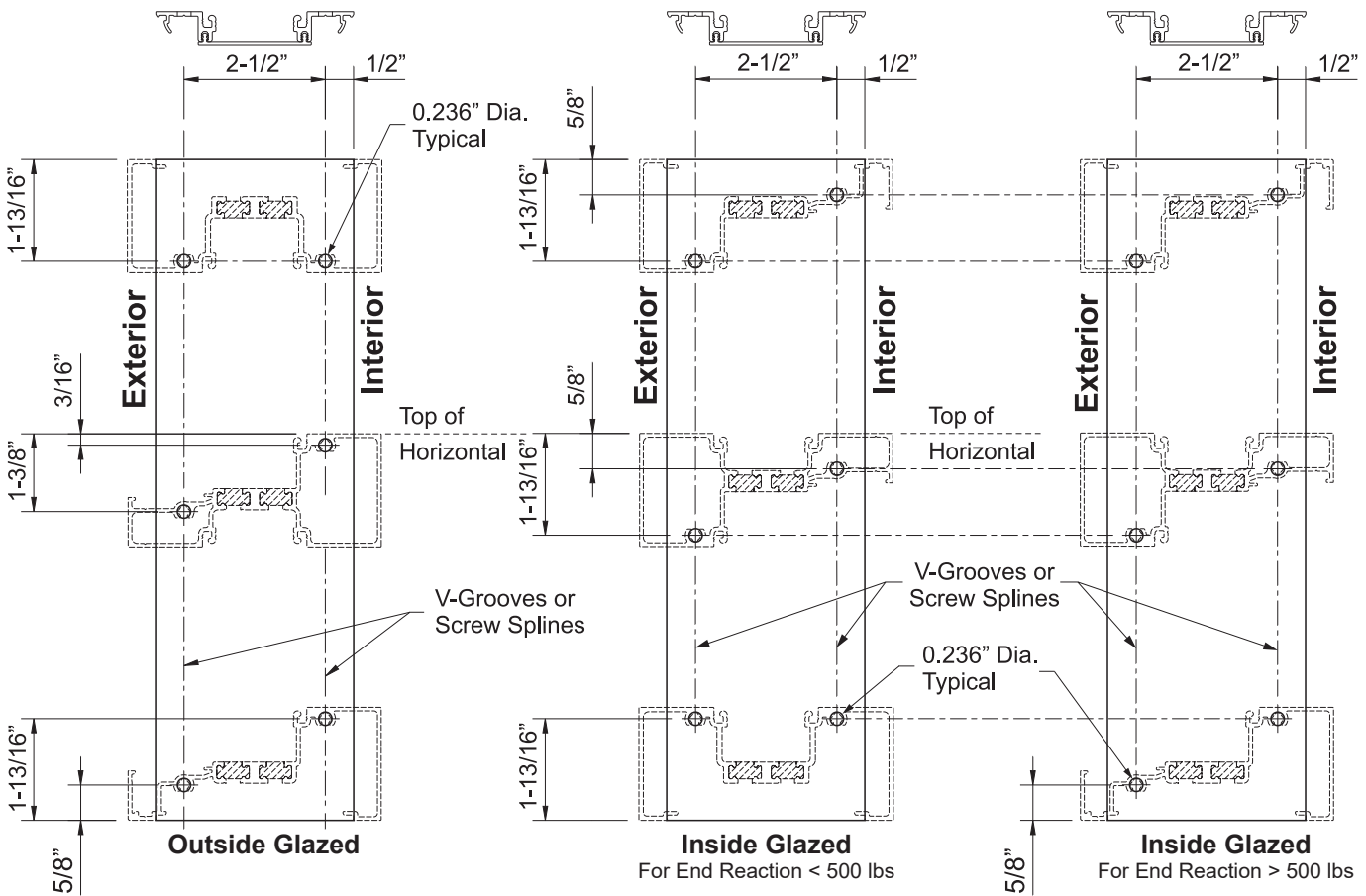

Detail 6

FRAME FABRICATION

STEP 3 FABRICATE HEAD, HORIZONTAL & SILL MEMBERS

-Cut head, horizontal, and sill members to the daylight opening (D.L.O.) as indicated on the shop drawings.

STEP 4 FABRICATE GLASS STOPS & GLAZING ADAPTORS

-Cut glass stops to the same dimensions as their respective horizontals minus(-) 1/32".
-Cut glazing adaptors to the daylight opening minus(-) 1/32".

STEP 5 FABRICATE SILL MEMBERS

-Cut sill members to the daylight opening dimension between verticals.
-For end reactions over 500 lbs., fabricate sill members for anchoring to sill flashing:
-Measure in 6" from each end of the sill member and mark hole locations along the "V"-groove as shown in **Detail 7**.
-Mark additional hole locations a maximum of 24" on center (O.C.).
-Drill a 0.213" diameter (#3 drill bit) hole at each location marked.
-For BE9-1513 4-1/2" sill, a 0.5" clear hole is required at sill anchor locations.
-For BE9-1513 4-1/2" sill, weep holes are required at 1/3 points of each horizontal member.
-If end reaction is under 500 lbs., one (1) .213" dia. weep hole is required at the center of each daylight opening. See **Detail 7**.

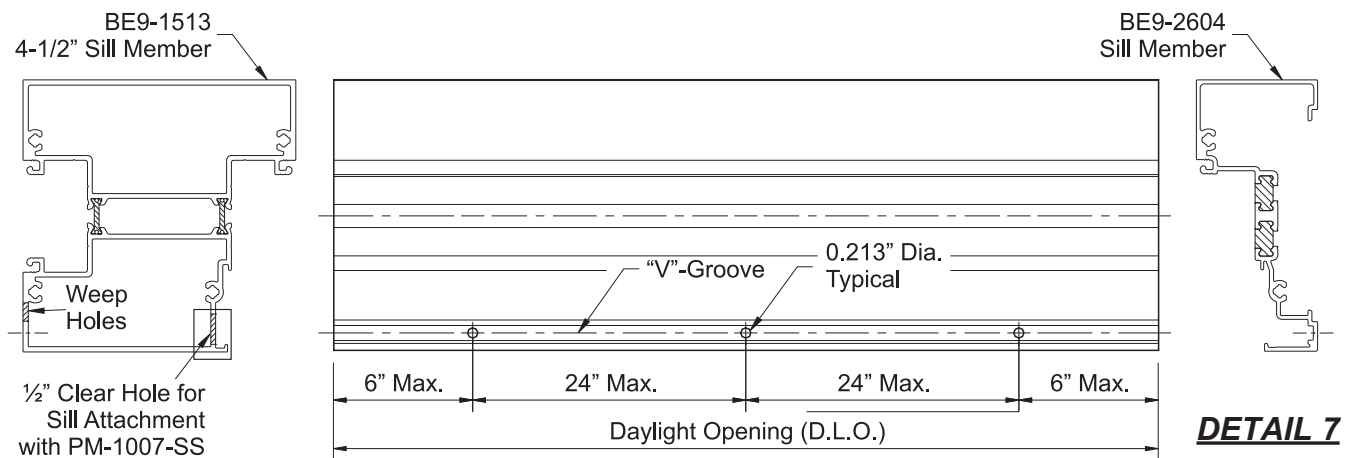

STEP 6 FABRICATE SILL FLASHING

For elevations without door framing:

-Cut sill flashing, BE9-2620 to the end of the frame plus (+) 1/4". See **Detail 8 & 9**.

For elevations with door framing:

-Cut the sill flashing from the end of the frame to the door jamb + 1/8".

(See approved shop drawings for this dimension)

See **Detail 10**.

FRAME FABRICATION

**STEP 6 (Cont'd)
FABRICATE SILL FLASHING**

-Drill 5/16" diameter weep holes in the front of the sill flashing at the quarter points of each D.L.O.

See **Detail 6**.

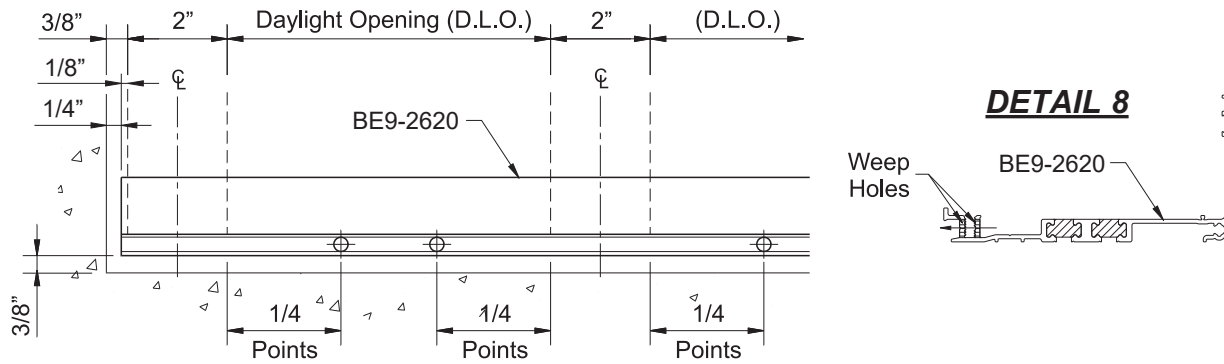

Without Door Framing

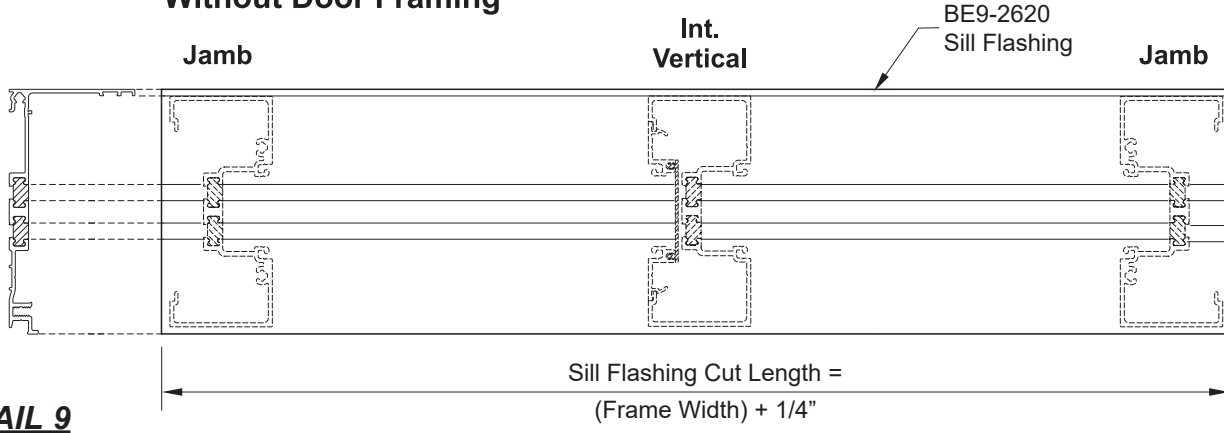

DETAIL 9

With Door Framing

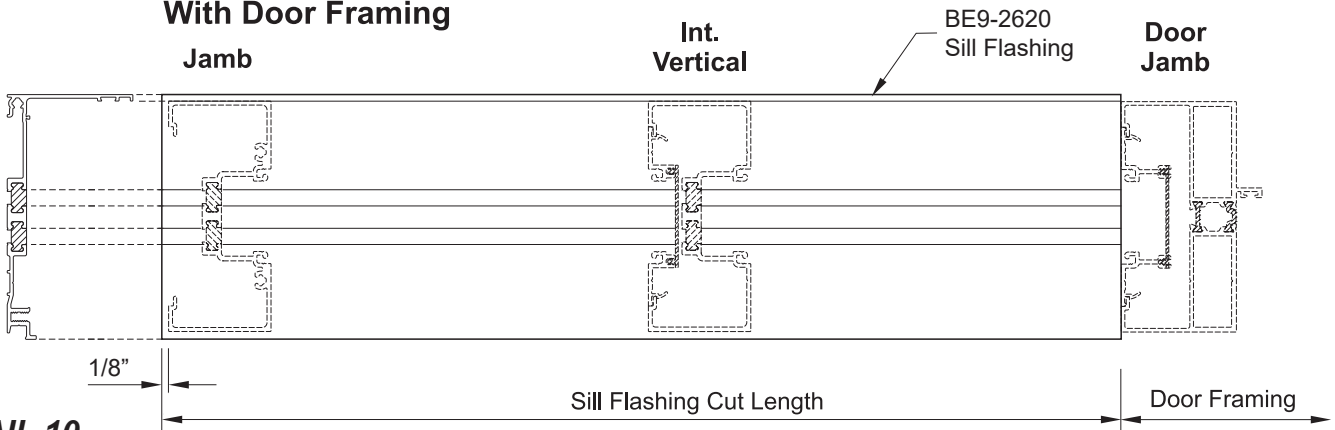

DETAIL 10

FRAME FABRICATION

STEP 6 (Continued)
FABRICATE SILL FLASHING

- For openings longer than 24'-0" the sill flashing needs to be spliced every twelve to fifteen feet at the center of a D.L.O.
- Allow for a 3/8" joint for expansion between sill flashing members.

See **Detail 11**.

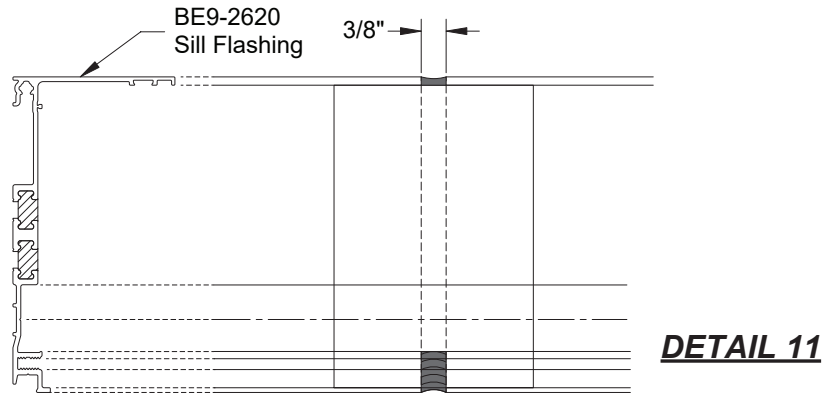

STEP 6A
FABRICATE HEAD RECEPTOR

- Cut the head receptor BE9-2562 and the E9-1033 snap cover to the frame width + 1/8" at each jamb or as indicated on the approved shop drawings.
- At each jamb, drill two Ø0.189" tap holes in to the BE9-2562 head receptor as shown.
- For openings longer than 24'-0" the head receptor needs to be spliced every twelve to fifteen feet at the center of a D.L.O.
- Allow for a 3/8" joint for expansion between head receptor members.

See **Detail 12**.

* **Note:** The Ø0.189" tap hole in the exterior side of the receptor will be slightly off the V-Groove. Drilling this hole from the top side of the receptor after the interior side hole is recommended.

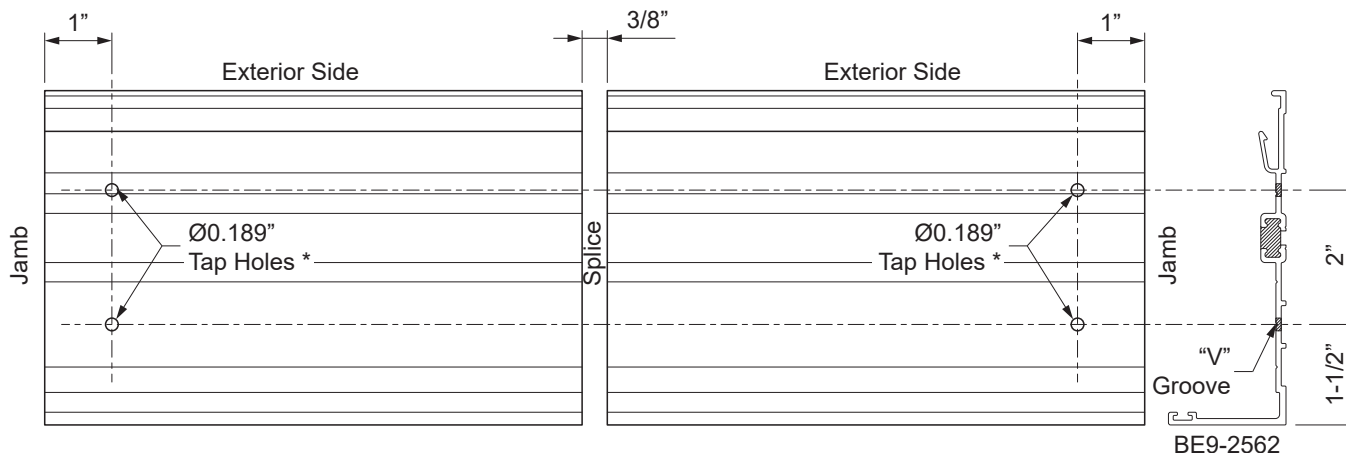

DETAIL 12

FRAME ASSEMBLY

**STEP 7
ASSEMBLE FRAMES**

Screw Spline Assembly:

- Clean all joint surfaces using cleaner approved by sealant manufacturer.
- Apply (butter) sealant to both ends of head, horizontal and sill members just prior to assembly.
- Attach head, horizontal and sill members to vertical members with two (2) PC-1216 fasteners at each end.
- Tool the sealant into the joints and wipe away any excess sealant.

See **Detail 13**.

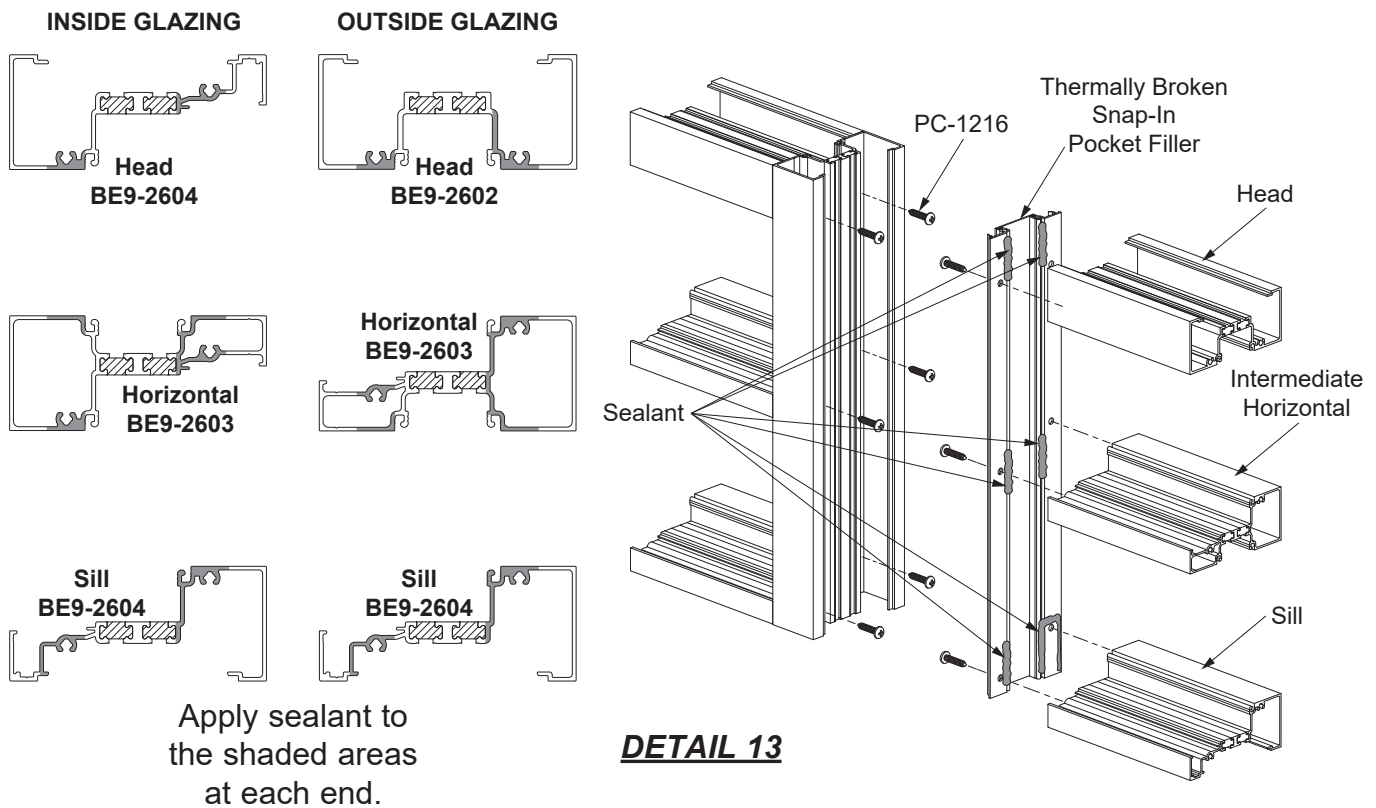

CAUTION: Always assemble frames such that each lite of glass will have a minimum of one deep vertical glazing pocket.

FRAME ASSEMBLY

STEP 8 (Not necessary with Head Receptor) INSTALL MULLION END CAPS (OPTIONAL)

-Cut pieces of E2-0259 foam backer tape (maximum 1-7/8" long for typical mullion) to be adhered at the head only.

These will serve as end cap support for perimeter backer rods and sealant.

-Peel the adhesive tape from the foam pieces and adhere them to the front and back of the mullion as shown in **Detail 14**. The foam can be easily compressed to accommodate obstacles in the assembled verticals.

Notes: For best adhesion, ensure the contact surfaces of the verticals are clean and dry.
Backer tape application is similar for expansion and corner mullions

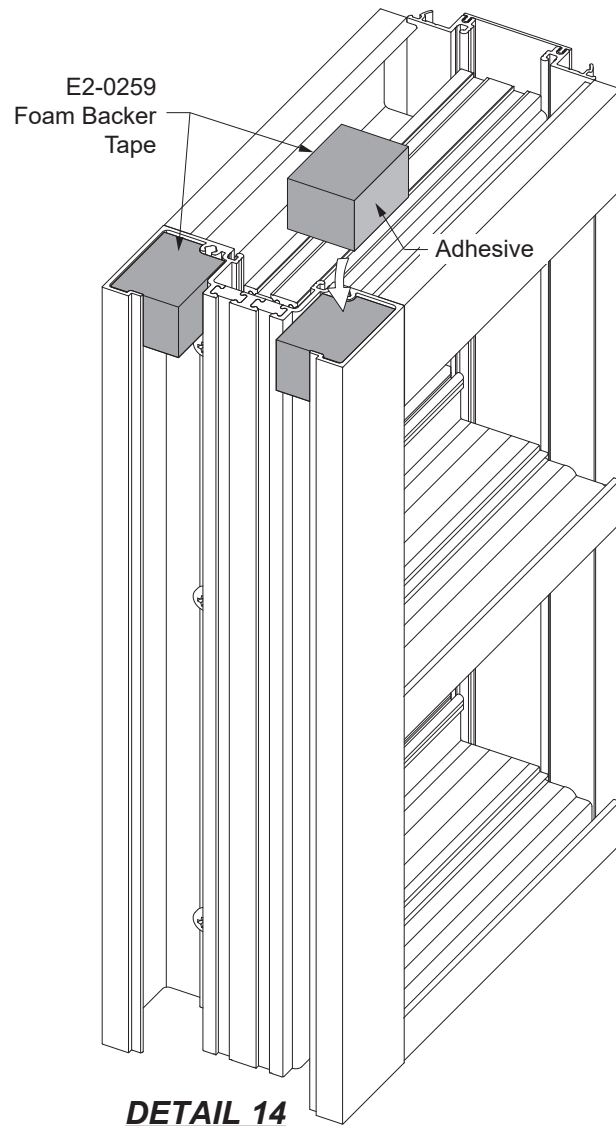

DETAIL 14

FRAME INSTALLATION

STEP 9 INSTALL SILL FLASHING END DAMS

- Hold the end dam with one hand and grab the tab with a pair of pliers.
- Bend the end dam left or right 90 degrees in the proper direction.

See **Detail 15**.

Note: The dam must be bent in the correct position for the left or right end of the sill flashing.

- Clean all joint surfaces using cleaner approved by sealant manufacturer.
- Apply silicone sealant to the end of the sill flashing as shown in **Detail 16**.
- Slide the tab into the top portion of the sill flashing.
- Tap the tab into place with a small tool until the end dam is snug against the end cut of the flashing.
- Fasten the end dam to the sill flashing with two UA-1212 screws, starting at the back, followed by the front as shown in **Detail 17**.
- Tool sealant along the joint between the end dam and the sill flashing as shown in **Detail 18**.
- Seal over any exposed screw threads.

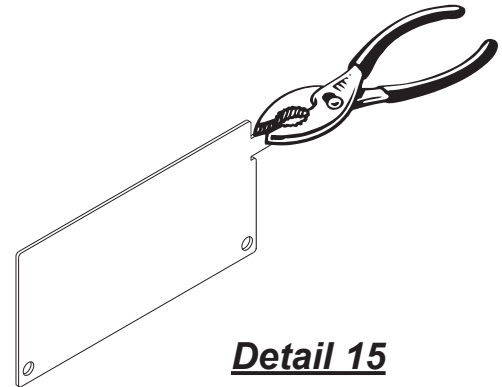

Detail 15

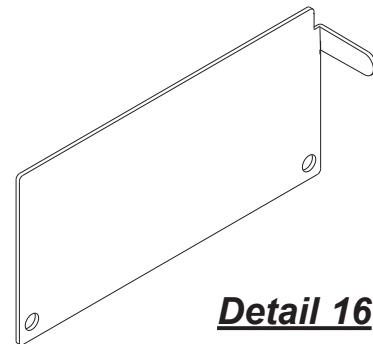

Detail 16

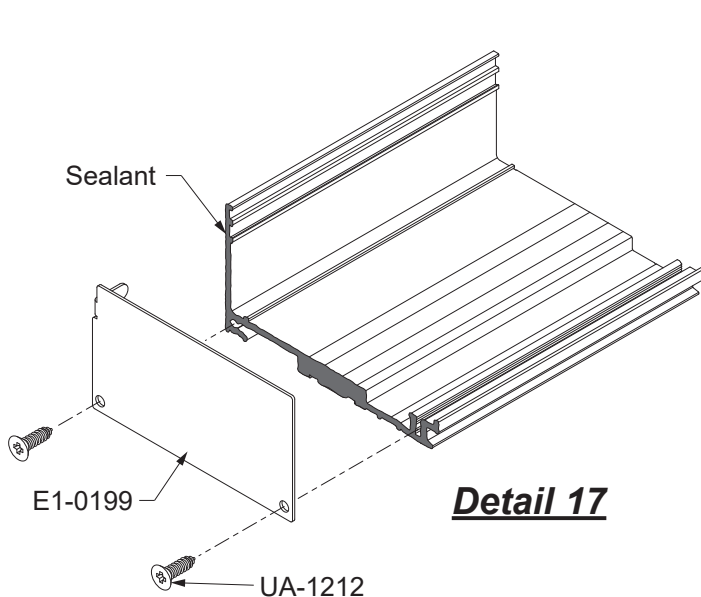

Detail 17

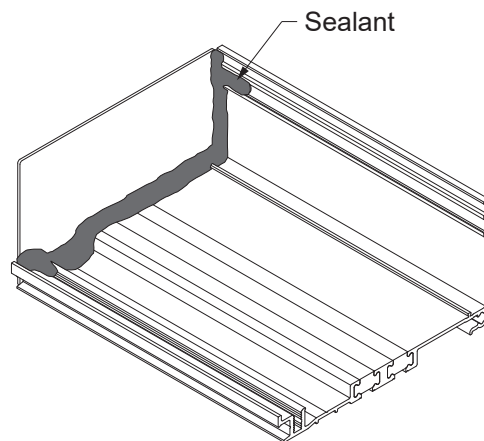

Detail 18

FRAME INSTALLATION

STEP 10 INSTALL SILL FLASHING

- Starting at the smallest opening height, install the sill flashing with a minimum of 3/8" shim underneath. Sill flashing must be installed level.
- Anchor the sill flashing to the structure a maximum of 4" from each end and then 18" to 24" on center.
- Apply and tool sealant to cover the heads of all fasteners.

STEP 11 INSTALL SILL FLASHING SPLICE SLEEVE

- Remove the nub with a chisel or needle nose pliers a minimum length of 1-1/2" as shown in **Detail 19**.
- After the sill flashing has been shimmed and installed to the building structure, apply a small backer rod under the sill flashing as shown in **Detail 20**.
- Position the Silicone Splice Sleeve against the back wall below the groove.
- Bend the Silicone Splice Sleeve into the front on the channel as shown. Mark and cut the sleeve at this position.
- Clean Sill Flashing and Silicone Splice Sleeve with isopropyl alcohol at the splice location
- Seal the flashing at the splice location as shown in **Detail 21**, before positioning the flashing. Set the Silicone Splice Sleeve into the sealant.
- Tool sealant tight as shown in **Detail 21**, squeezing the sheet flat.

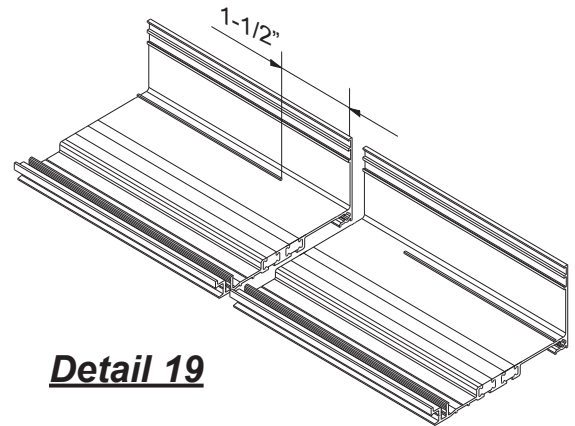

Detail 19

When using E2-0070 splice sleeve, a compatible Silicone Sealant must be used at the splice. Compatible Silicone Sealants include Tremco® Spectrum 2 and Dow Corning® 795.

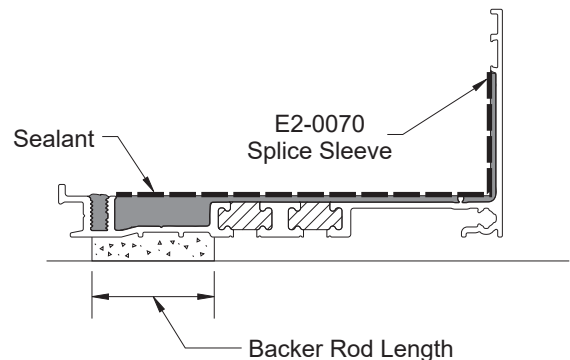
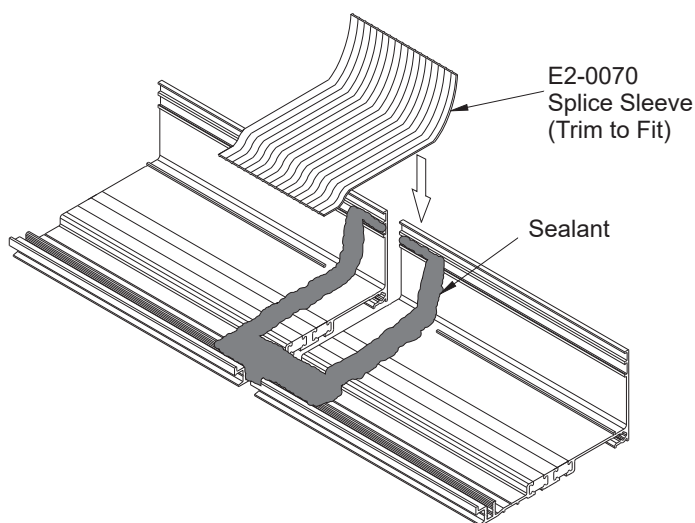

Detail 20

FRAME INSTALLATION

**STEP 11
INSTALL SILL FLASHING SPLICE SLEEVE (Continued)**

- Apply masking tape to the back of the sill flashing at the splice and at the front as shown in **Detail 21**.
- Thoroughly seal the small joint directly in front of the Silicone Splice Sleeve. Carefully remove masking tape from the front gap before the sealant skins over.

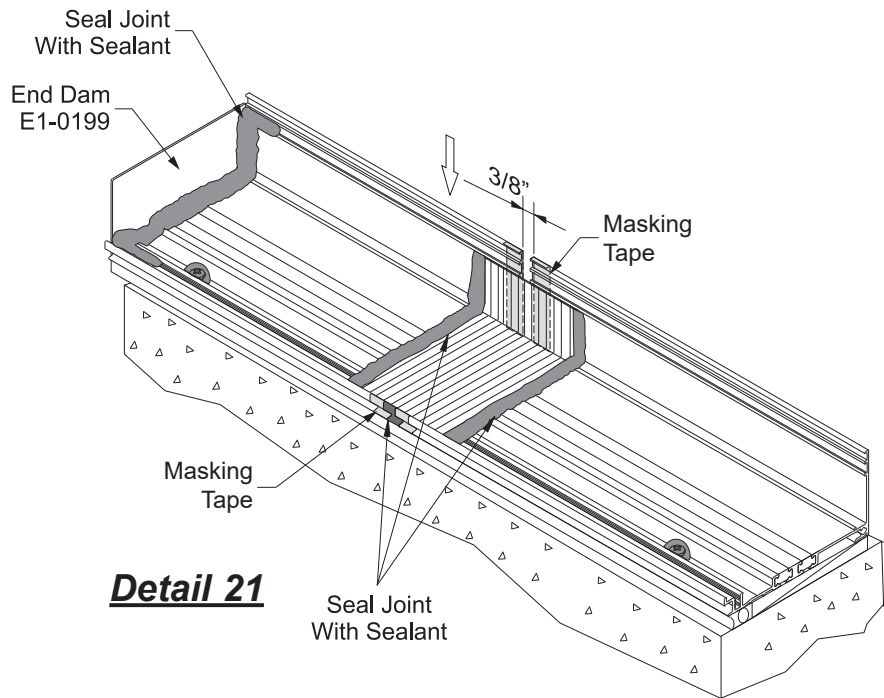

Detail 21

**STEP 12
SILL PREPARATION**

At every splice condition, apply bond breaker tape to the back of the sill member before the joint is sealed between the sill and sill flashing. See **Detail 22**.

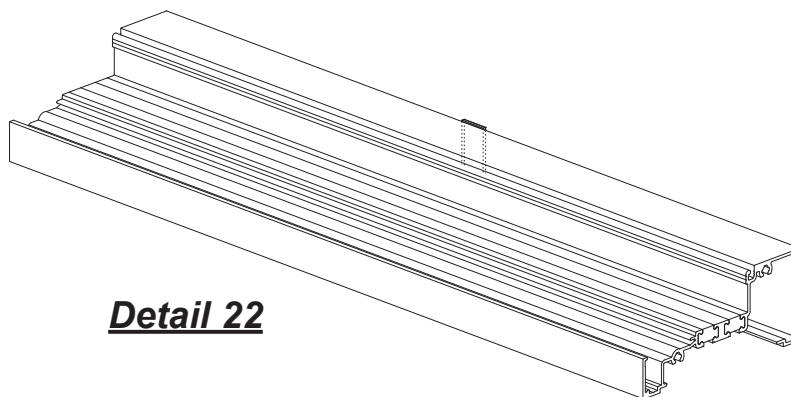

Detail 22

FRAME INSTALLATION

STEP 13 ATTACH HEAD RECEPTOR END CAPS

-Cut E2-0051 bulb gaskets to the same length as the head receptor and insert them into the reglet of both the BE9-2562 head receptor and E9-1033 snap cover. See **Detail 23**.

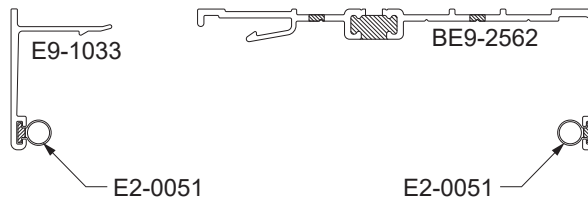

Detail 23

- Clean all joint surfaces using cleaner approved by sealant manufacturer.
- Apply sealant to the end of the head receptor as shown in **Detail 24**.
- Fasten the E1-2603 end caps to each jamb using two FC-1208 fasteners.
- Tool sealant to the inside of the end caps at the jambs similar to that for the sill flashing end dams (see **Detail 26**). Tape down the top corners to hold the end cap in place until the sealant cures.

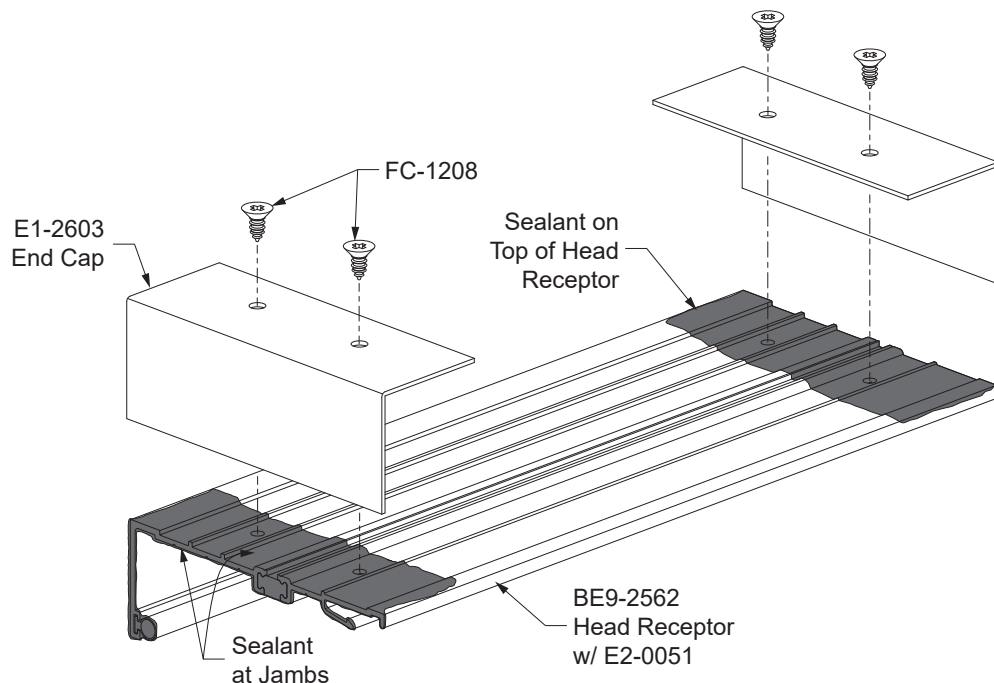

Detail 24

FRAME INSTALLATION

**STEP 13A
INSTALL HEAD RECEPTOR**

- Install the BE9-2562 head receptor to the substrate using fasteners per approved shop drawing or P.E. calculations. Allow for a 3/8" shim space to the substrate and a 3/8" gap at the splice joints.
- Seal all anchor fastener heads.
- Fill the gap at the exterior of the head receptor with sealant.

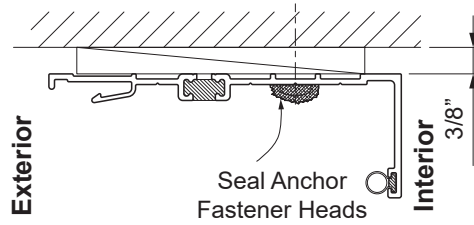

Detail 25

See **Details 25 & 26.**

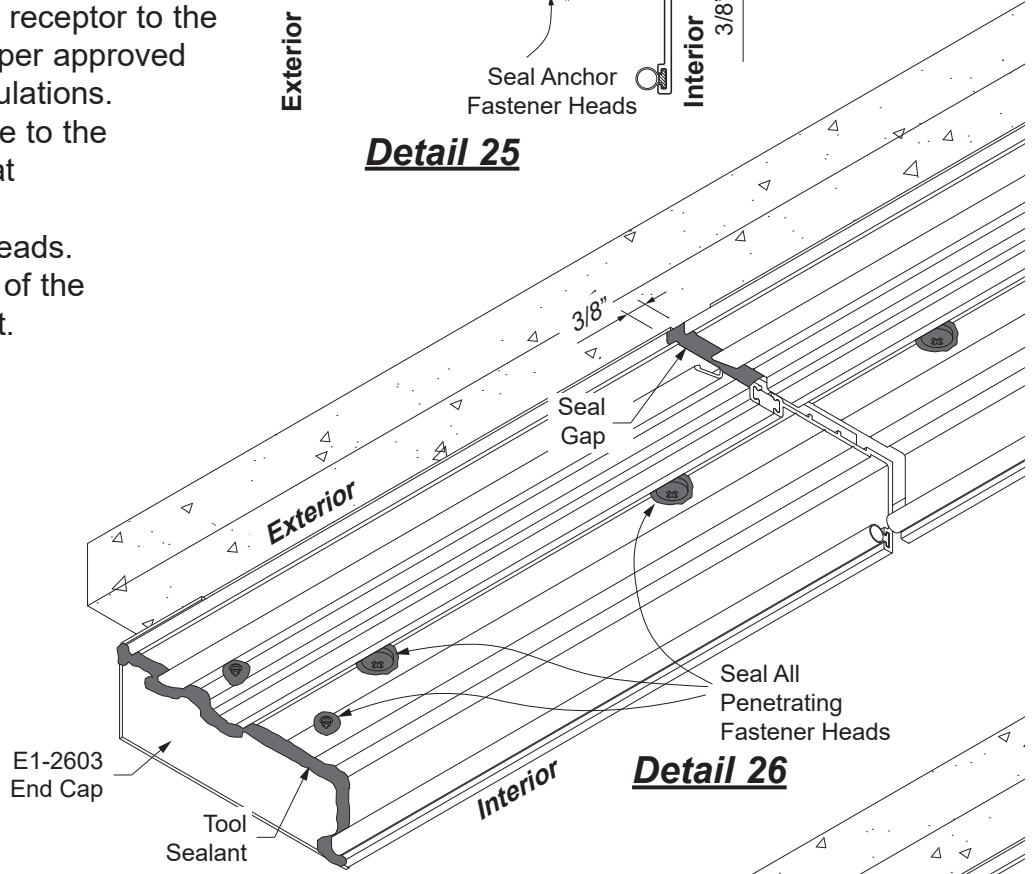

Detail 26

- Adhere an E2-0070 silicone sheet to the splice joints on a bed of sealant. Fill the gap at the back of the head receptor with sealant.

See **Detail 27.**

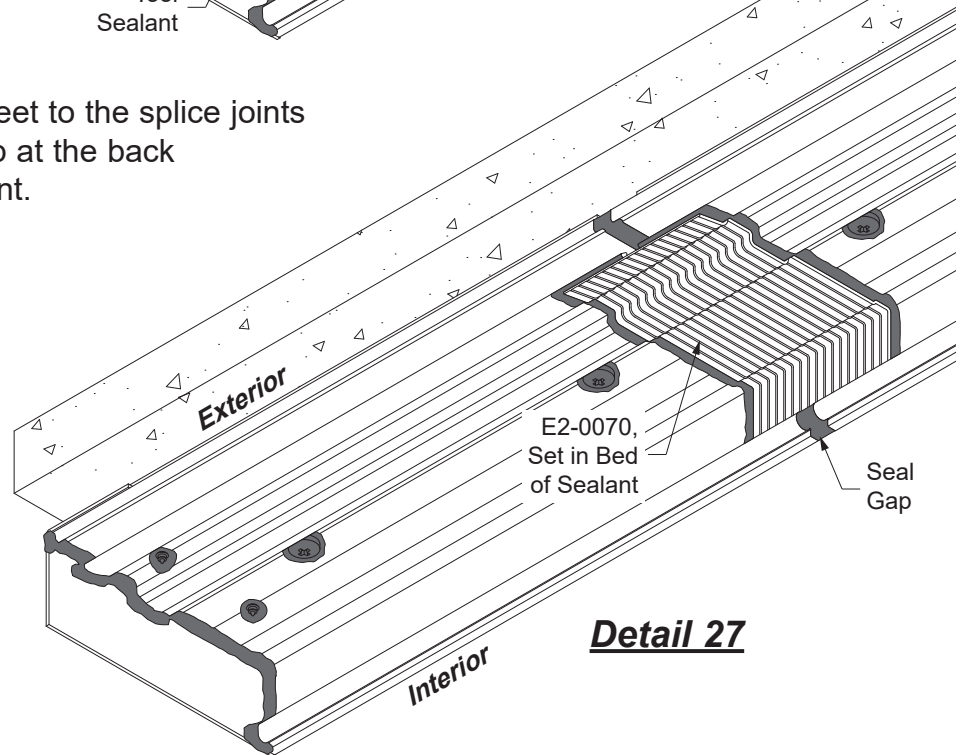

Detail 27

FRAME INSTALLATION

STEP 14

FABRICATE/INSTALL SILL FLASHING FOR CORNERS

- Cut two 12" long pieces of sill flashing BE9-2620 and miter (45° for 90° corners and 67.5° for 135° corners).
- Align the two pieces at the corner condition with the mitered ends pushed together tight and anchor the sill flashing as called out on shop drawings.
- Apply and tool sealant to the mitered joint and anchor heads.

See **Detail 28**.

- Continue installing the rest of the sill flashing providing a 3/8" expansion joint at splices as shown in **Step 11 on Page 15**.

* **Note:** Similar technique required for BE9-2562 head receptor.

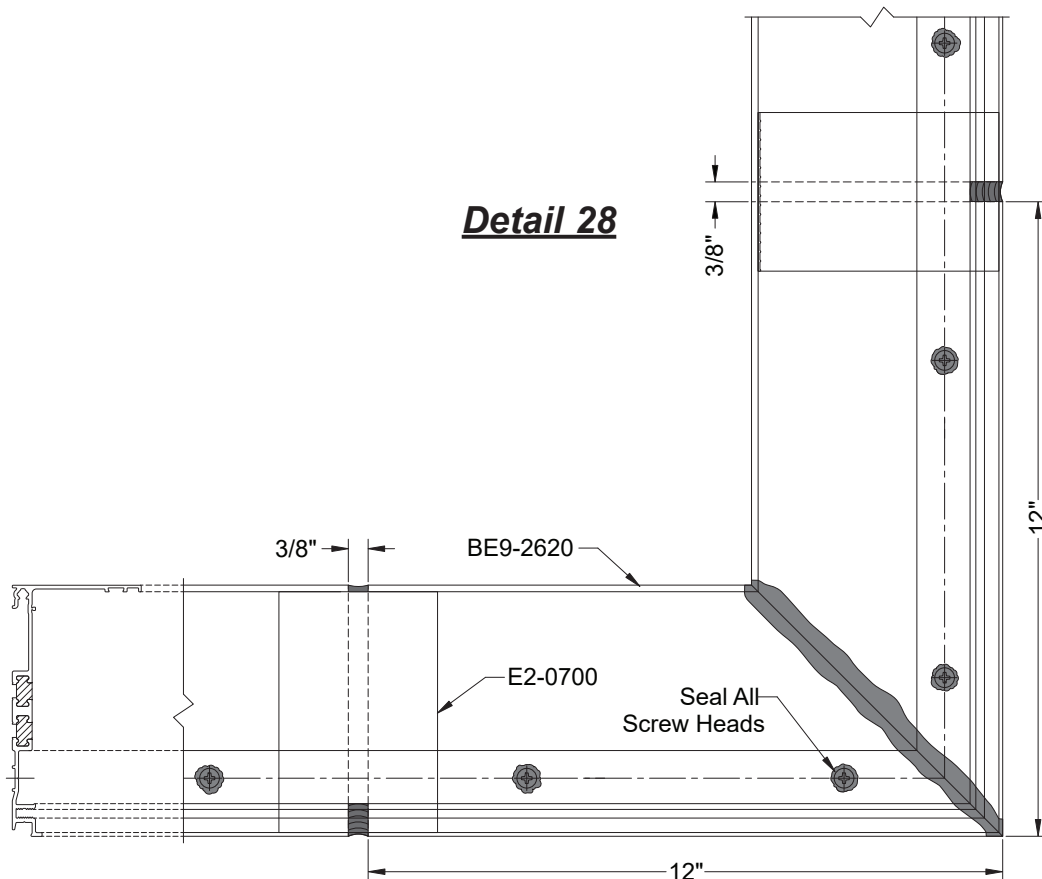

FRAME INSTALLATION

**STEP 15
PREPARE DOOR JAMBS**

Prior to snapping the assembled frames into the door jamb, the end of the sill flashing needs to be sealed to the door jamb.

- Apply and tool sealant to all sill flashing to door jamb joints.
 - Apply sealant to completely fill the door jamb cavity and ramp the sealant down onto the sill flashing.
- See **Detail 29**.

Refer to the **Entrances Installation Manual** for door installation instructions.

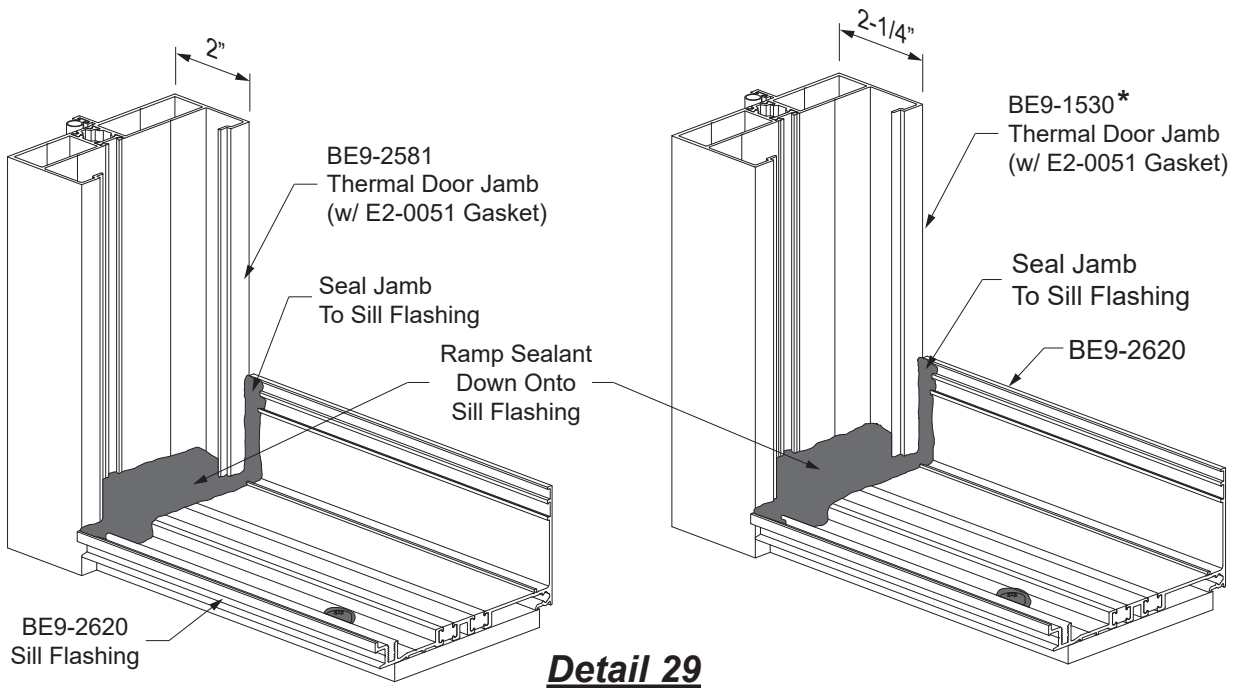

* **Note:** 35XT and 50XT Doors and frames to be discontinued as of May 1st, 2024.

FRAME INSTALLATION

STEP 16 INSTALL FRAMES

- Snap in flat fillers, E1-2601, or PVC flat filler E3-0023 at head, jamb, and sill anchor locations.
- Apply sealant to the vertical up 6" from the sill where the vertical meets the flat filler.
- Snap assembled frames together if using screw spline assembly.
- Apply sealant continuously to the top front of the back leg of the sill flashing and immediately set the frame into the opening. See **Detail 30**.
- Shim jamb and head members with a minimum of 3/8" shim.
- Anchor the frame to the structure at the sill*, head, and jamb: 3" from the ends and then 18" to 24" on center.
- Seal all perimeter anchors at head and jamb. Do not seal the anchor that attaches the sill to the sill flashing.

Note: Use only flat head fasteners at head and jamb conditions.

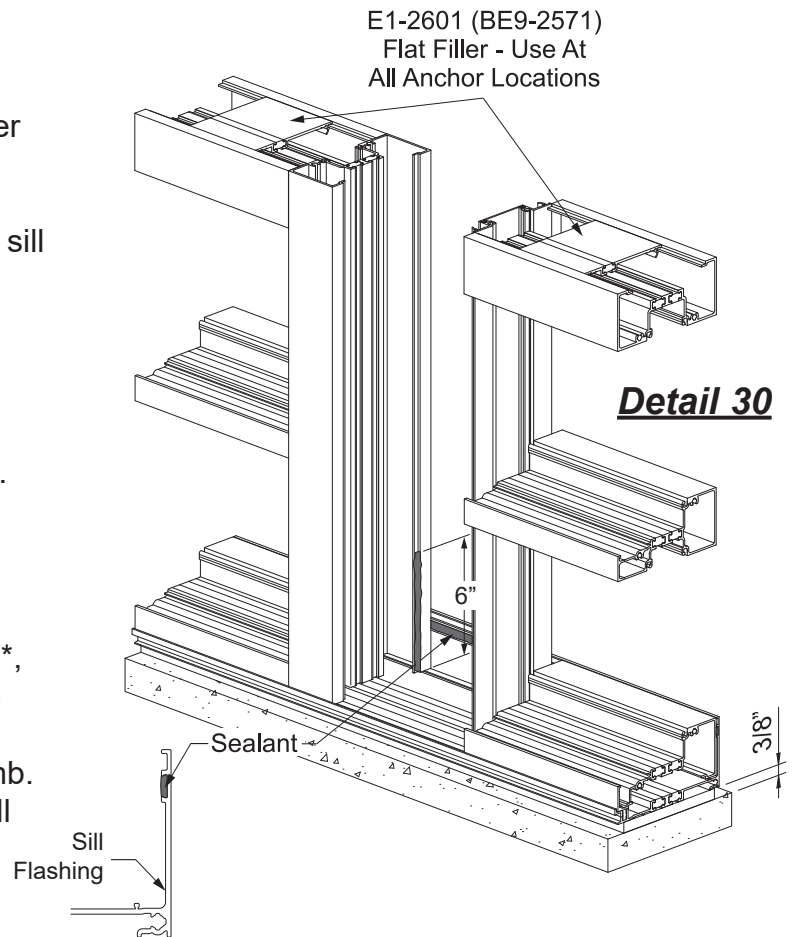

- For end load reactions over 500 lbs., attach the sill to the sill flashing using PM-1008-SS screws.
- Additionally, add one (1) PM-1008-SS fastener 2" in both directions from the centerline of the splice.

-Apply and tool sealant to the gap in the back of the sill flashing splice. Carefully remove the masking tape before the sealant skins over.

See **Detail 31**.

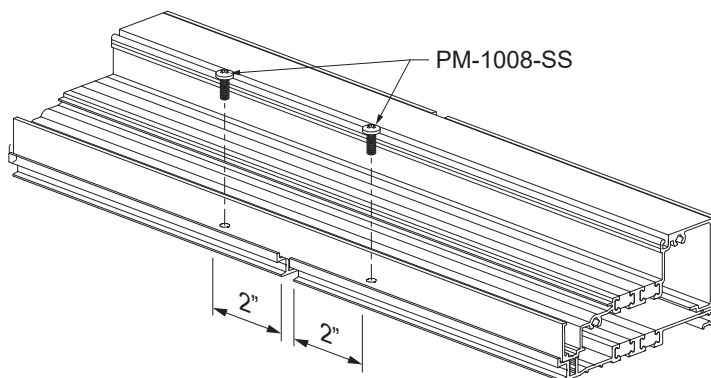

Detail 31

FRAME INSTALLATION

STEP 16 (Continued) INSTALL FRAMES W/ HEAD RECEPTOR

- Rotate the assembled frames into position from the exterior, ensuring engagement into the sill flashing.
- Snap on the E9-1033 snap cover (with E2-0051 bulb gasket) into the head receptor.
- For mullion end load reactions over 500 lbs., attach the sill to the sill flashing using PM-1008-SS screws. Also add one (1) PM-1008-SS fastener 2" in both directions from the center line of the splice.

See **Detail 32**.

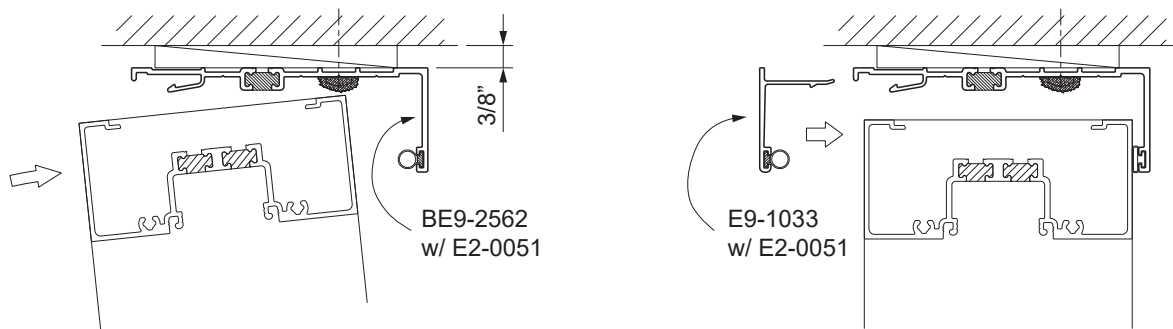

Detail 32

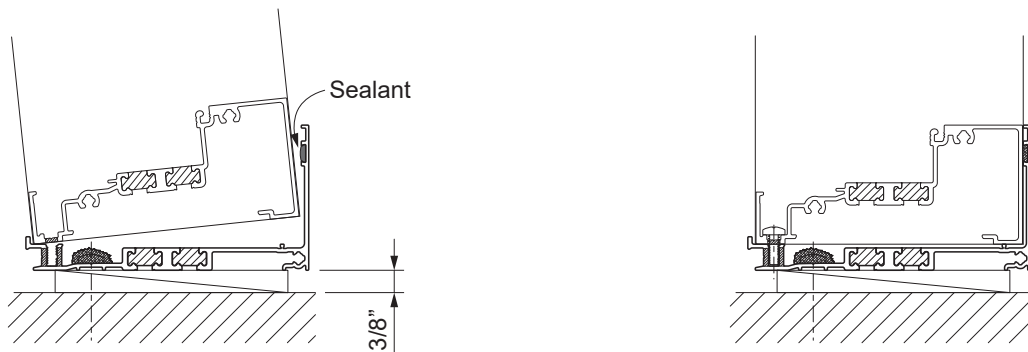

FRAME INSTALLATION

STEP 16 (Continued)

INSTALL EXPANSION MULLIONS WHERE REQUIRED

- Expansion mullions require the K2-2441 weathering gasket in both front and rear reglets.
- During installation, the current air temperature should be taken into account to determine the proper spacing between the mullion halves such that the expansion mullion stays within its allowable width limits during its service in hot and cold weather conditions.
- Fill the interior gap between the mullion halves with sealant at the sill flashing and head receptor.

See **Detail 33**.

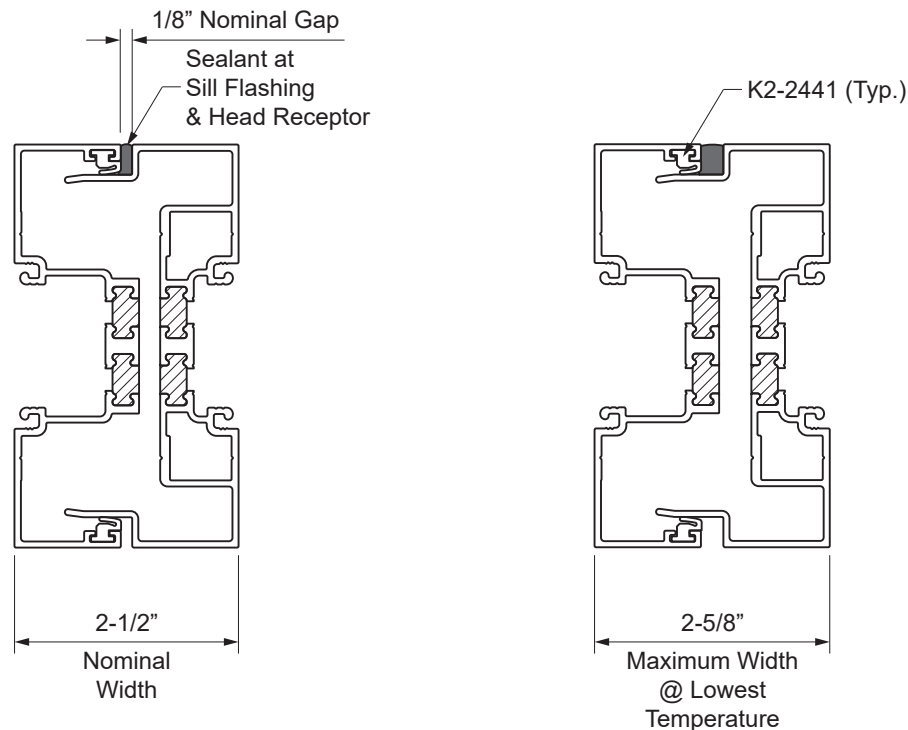

Detail 33

FRAME INSTALLATION

STEP 16 (Continued) INSTALL CORNER ASSEMBLIES

- Attach horizontal members to standard mullions as shown before in **Step 7**.
- Attach the other end of the horizontals to the corner mullions, hinged mullions, or flat fillers, or using the same technique.
- Apply sealant to the interior snap receptor of the corner mullion, 6" up from the bottom.
- Snap the corner framing members together to form the corner assemblies.
- Hinged mullions must be fastened through the ball joint 6" from each end and no more than 18" on center with PC-0806 fasteners.
- Carefully move the corner assembly into place and snap it into the rest of the frame one side at a time.

See **Detail 34**.

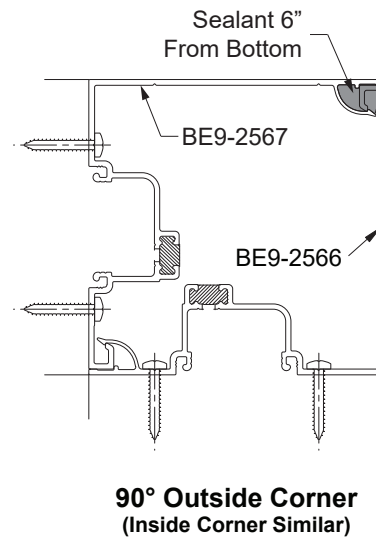
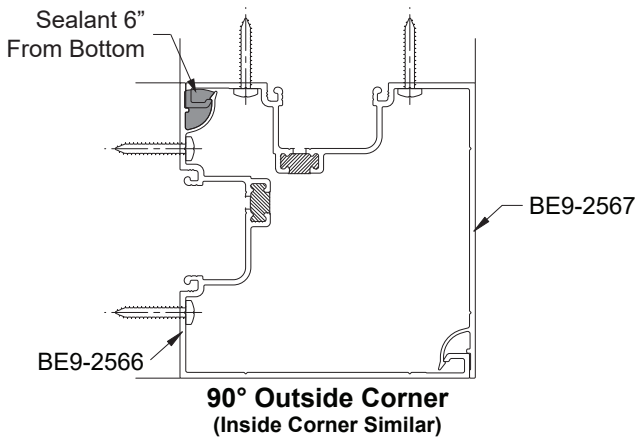

Detail 34

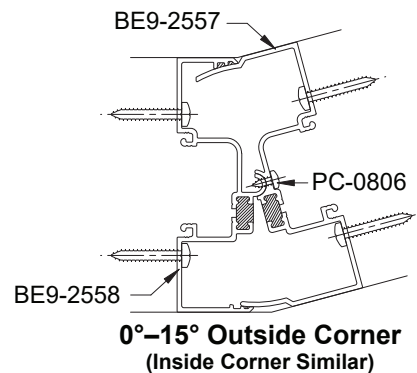
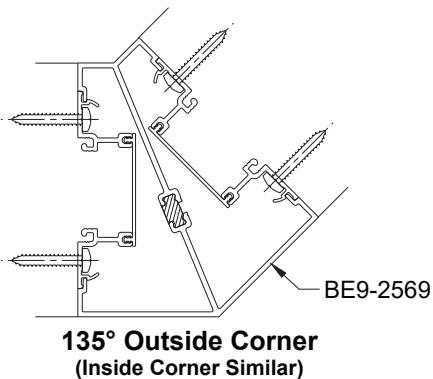

FRAME INSTALLATION

STEP 16 (Continued)

INSTALL OPTIONAL COMPOUND MULLIONS

-Snap in the BY7-9478 adaptors (cut full length of the mullion) into the mullions for each frame as shown in **Detail 35**.

-Apply Sealant to the full length of the first mullion for which the rear face cover will snap into.

-Snap the face cover into place.

See **Detail 36**.

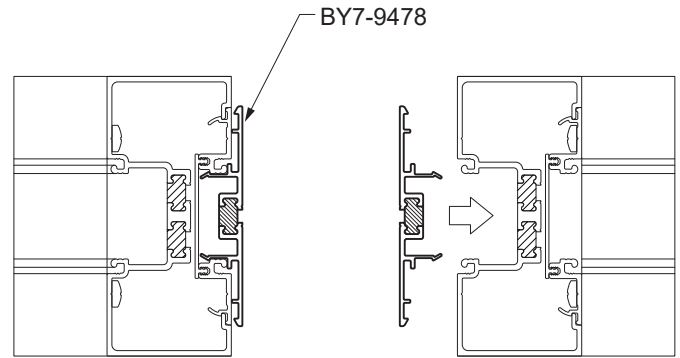

Detail 35

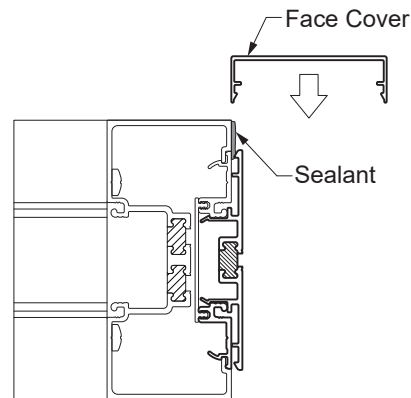

Detail 36

FRAME INSTALLATION**STEP 16 (Continued)
INSTALL OPTIONAL COMPOUND MULLIONS**

-Apply sealant to the full length of the mullion for the second frame.

-Snap the second frame into place from the front, engaging the face cover as shown in **Details 37 & 37A**.

-Snap the front face cover into both frames. Start at the sill to clear the front lip of the sill flashing.

See **Detail 38**.

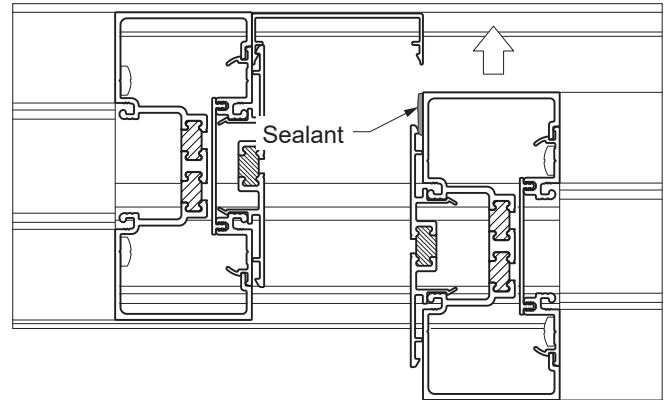
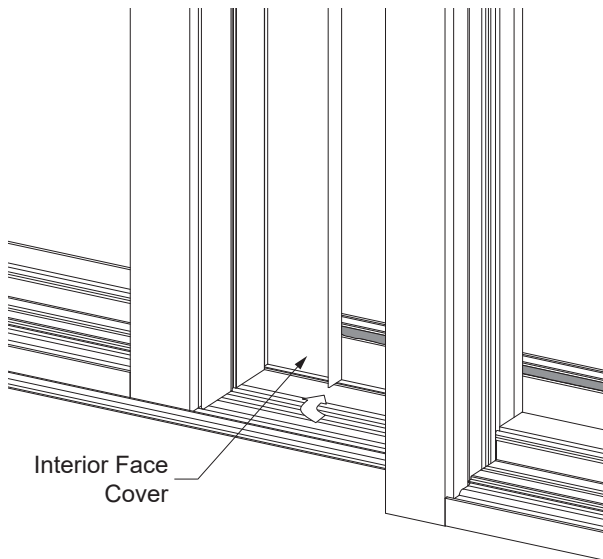
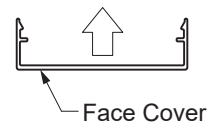
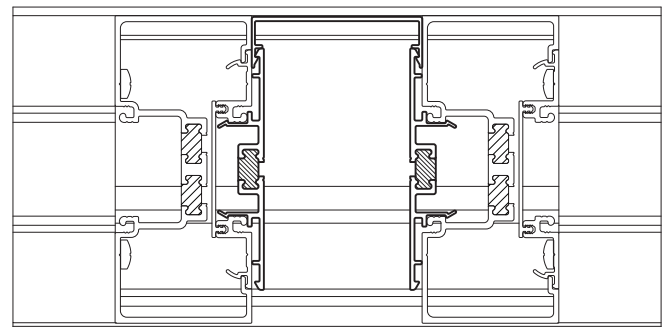
**Detail 37A****Detail 37****Detail 38**

FRAME INSTALLATION

STEP 17 APPLY PERIMETER SEALANT

- Perimeter seal required on interior and exterior.
- Install backer rod around the perimeter of the frame.
- Apply perimeter sealant to the joint between the frame and the structure.
- Do not** seal the anchor that attaches the sill to the sill flashing.
- Seal anchor heads at head and jambs.

See **Detail 39**.

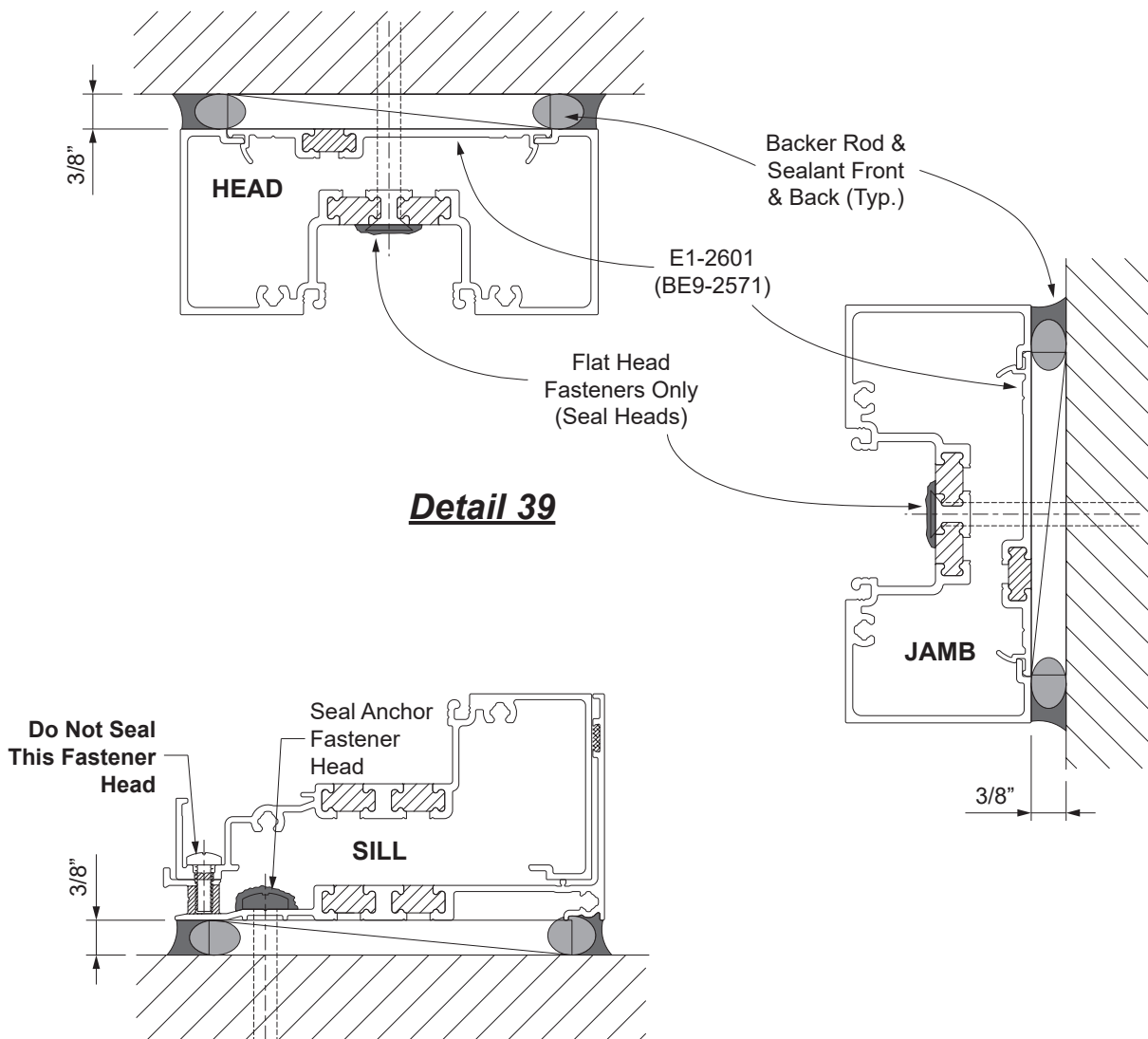

FRAME INSTALLATION**STEP 17A****APPLY PERIMETER SEALANT @ HEAD RECEPTOR**

-Insert backer rods as required into the head receptor snap cover to provide support for sealant at the exterior gap.

See **Detail 40**.

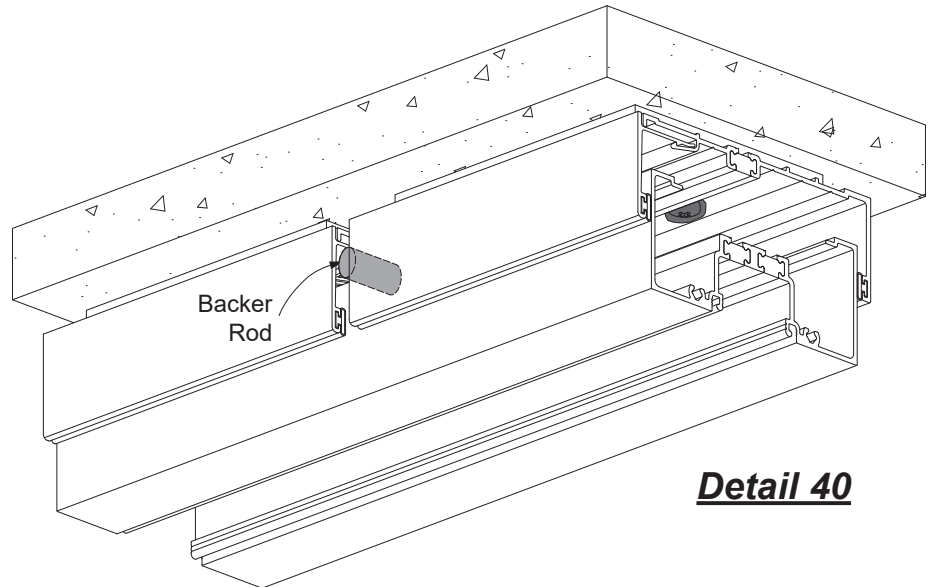

-Insert a continuous backer rod between the head receptor and substrate on both the interior and exterior of the frame.

-Apply and tool continuous sealant along the caulk joint and fill the gap at the exterior snap cover with sealant.

See **Detail 41**.

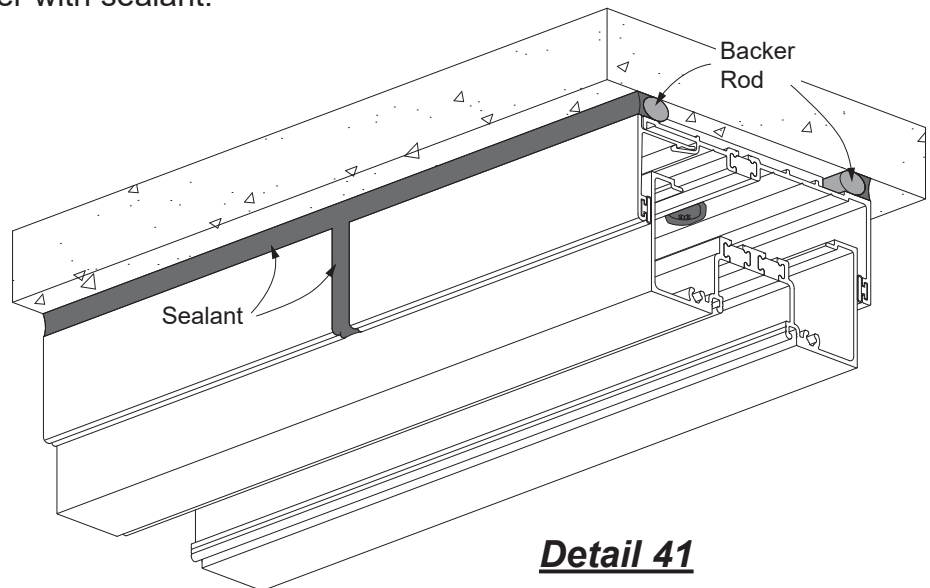

FRAME INSTALLATION

STEP 18 INSTALL WATER DEFLECTORS

YES 45 XT requires the installation of a water deflector, E2-0047, at the ends of every intermediate horizontal to keep water off of the insulated units.

- Peel away the protective paper from the bottom of the water deflector, E2-0047, and install the water deflector by rotating it over each end of the horizontal.
- Position the vertical leg of the water deflector against the end of the horizontal.

Note: For best adhesion, make sure that the horizontal is clean and dry.

See **Detail 42**.

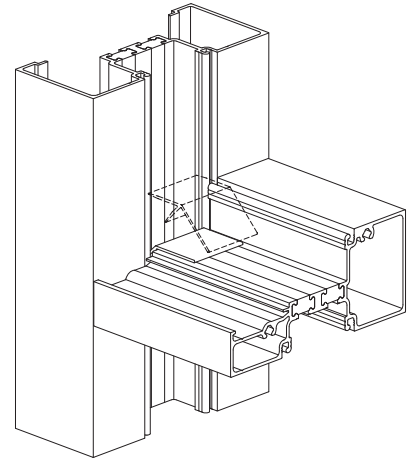

Detail 42

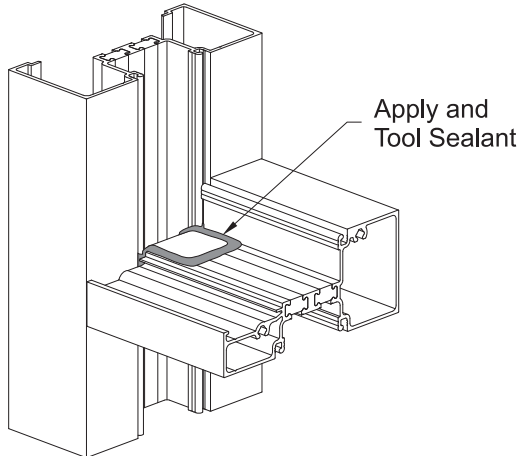

Detail 43

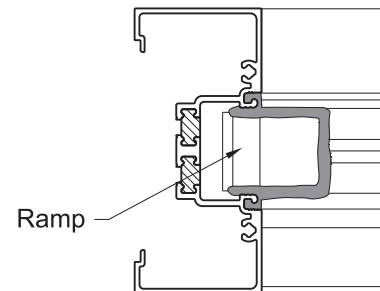

Detail 44

-Apply and tool sealant along the edges of the water deflector and down onto the horizontal.

See **Detail 43**.

-Seal the ramp of the water deflector to the sides of the vertical gasket reglets.

See **Detail 44**.

FRAME INSTALLATION

STEP 19 APPLY INTERNAL SEALANT

- Apply a generous amount of sealant to the vertical intersection of the horizontal and vertical members.
 - Tool all of the sealant to ensure a water tight joint.
 - Make sure all exposed screw heads are sealed.
- See **Detail 45**.

Glazing Table - YES 45 XT

Glass Thickness	Adaptor	Exterior	Interior
3/16"	E9-1040	E2-0052	E2-0064
1/4"	E9-1040	E2-0052	E2-0052
5/16"	E9-1040	E2-0053	E2-0052
3/8"	E9-1040	E2-0053	E2-0053
1/2"	E9-1039	E2-0064	E2-0064
5/8"	E9-1039	E2-0052	E2-0052
3/4"	E9-1039	E2-0053	E2-0053
7/8"	—	E2-0064	E2-0064
1"	—	E2-0052	E2-0052

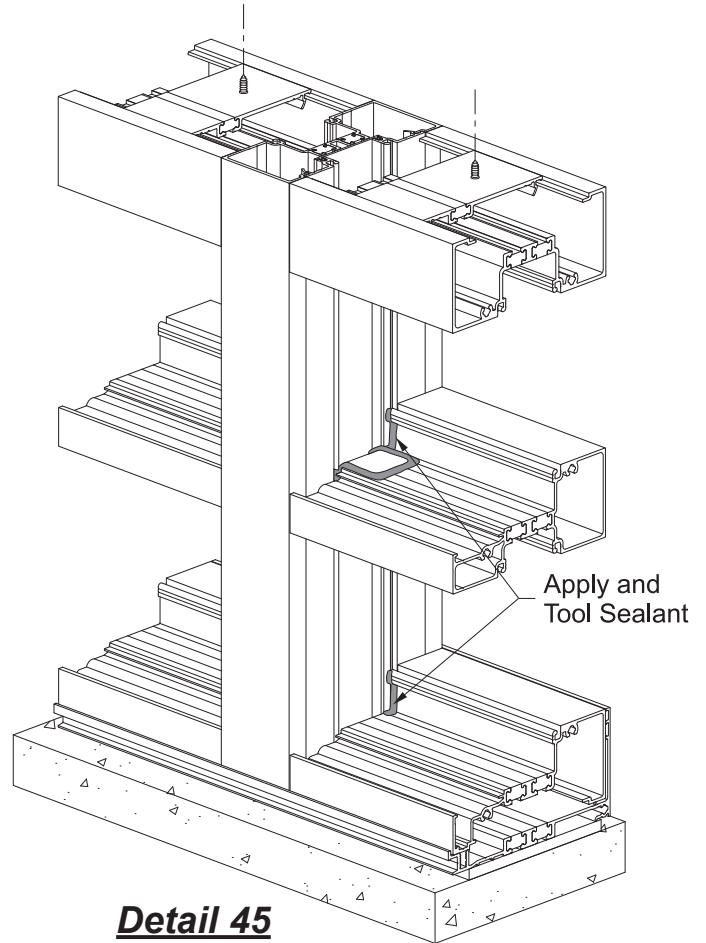

Detail 45

STEP 20 (Optional) INSTALL GLAZING ADAPTORS

Glazing adaptors E9-1040, allows for glazing infills of 1/4" or 1". Please refer to the glazing tables above for adaptor/gasket combinations.

- Snap glazing adaptors into the interior gasket reglets of the verticals.
 - Snap glazing adaptors into the interior gasket reglets of the horizontals.
 - Apply and tool sealant to the joint between vertical and horizontal glazing adaptors.
- See **Detail 46**.

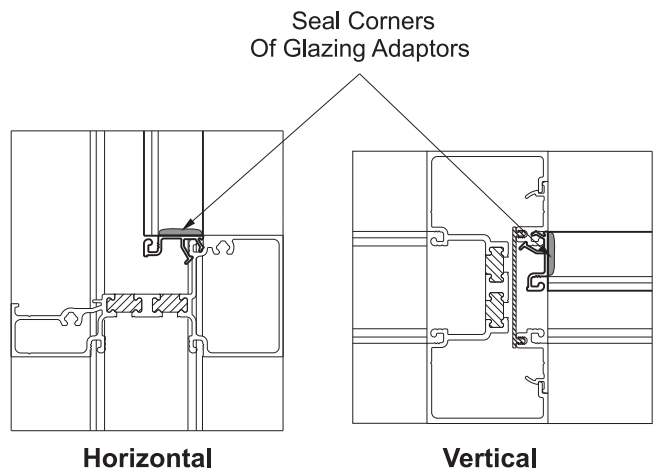

Detail 46

FRAME INSTALLATION

STEP 21 (Optional) INSTALL OPTIONAL COMPOUND HORIZONTALS

-Apply sealant to the top of of the lower horizontals where they intersect with the vertical. Tool the sealant. Do not seal the upper horizontal.

See **Detail 47**.

-Snap the E9-1015 glass stop into the lower horizontal as shown in **Detail 48**. Do not snap glass stops into the upper horizontals yet.

Note: Outside glazing shown, inside glazing similar.

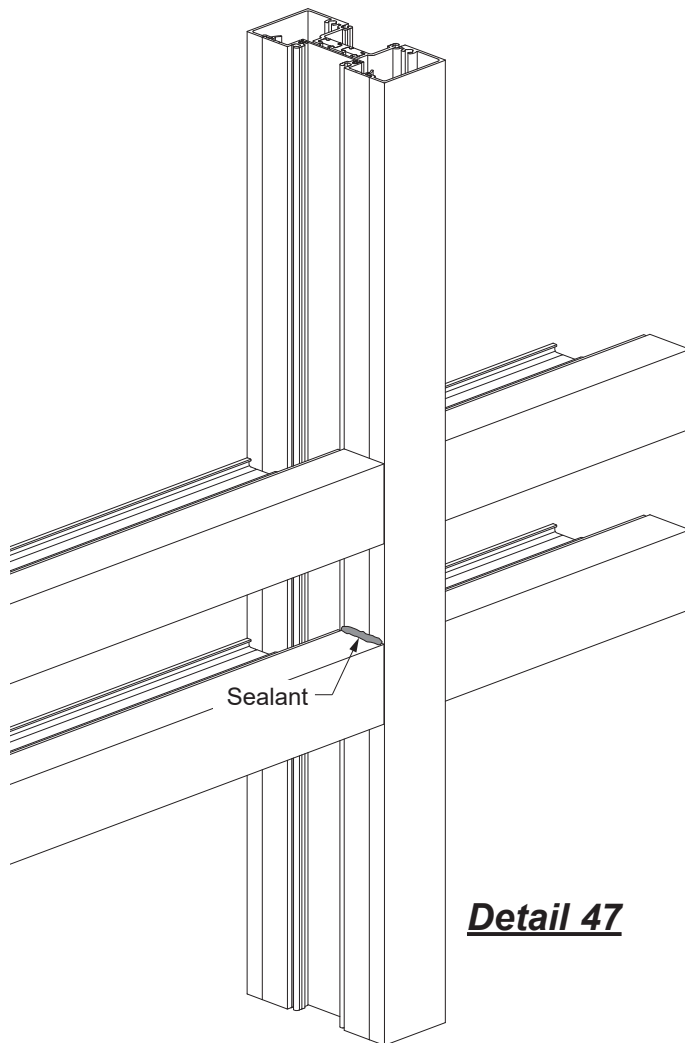

Detail 47

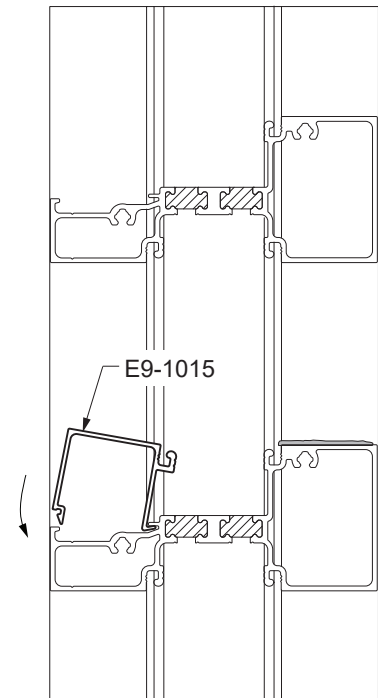

Detail 48

Note: Prior to snapping the glass stops onto an inside glazed storefront, apply sealant to the ends of the glass stops as illustrated in **Step 25** on **Page 36**.

FRAME INSTALLATION

STEP 21 (Optional, Continued)

INSTALL OPTIONAL COMPOUND HORIZONTALS

-Snap in the E1-9836 adaptors into the horizontals, one at 3" from each end of each horizontal and one at the middle of each horizontal as shown in **Details 49 & 50**.

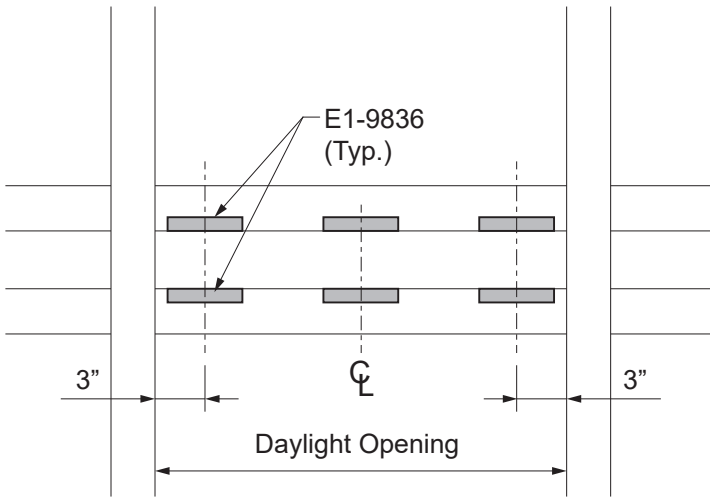

Detail 49

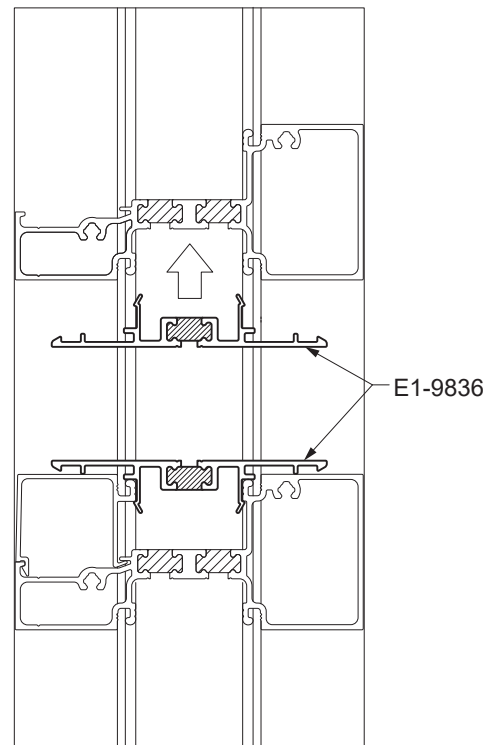

Detail 50

FRAME INSTALLATION

STEP 21 (Optional, Continued) INSTALL OPTIONAL COMPOUND HORIZONTALS

-Cut the front and rear horizontal face covers to Daylight Opening minus(-) 1/16". Apply continuous sealant to the full length of the back of both horizontals where the rear face cover will snap into as shown in **Detail 51**. Snap the rear face cover into place.

-Seal the joint between the edge of the face cover and the verticals as shown in **Detail 52**.

-Snap the front face cover into place.

See **Detail 53**.

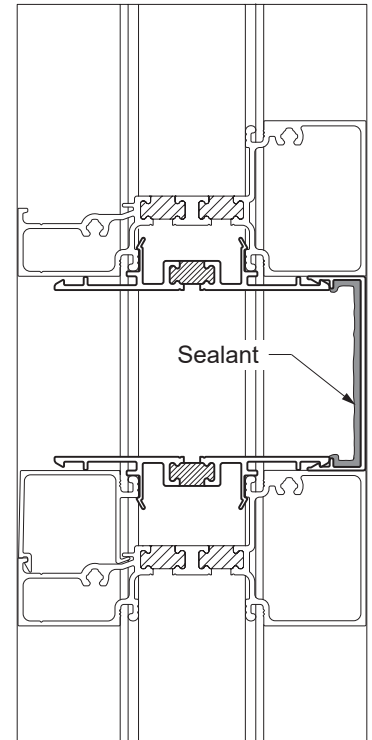

Detail 52

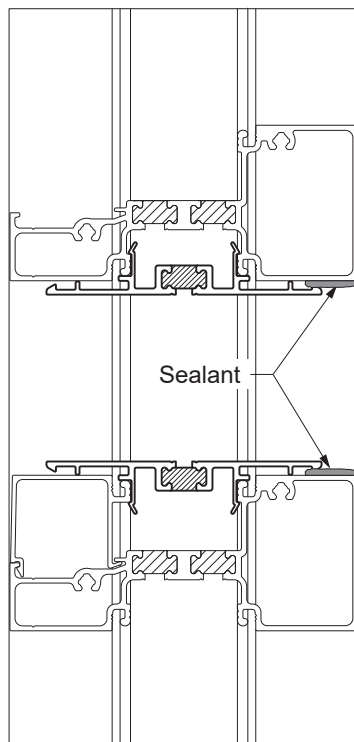

Detail 51

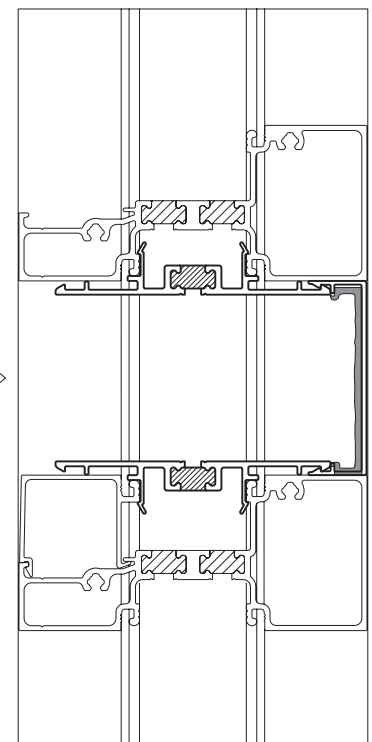
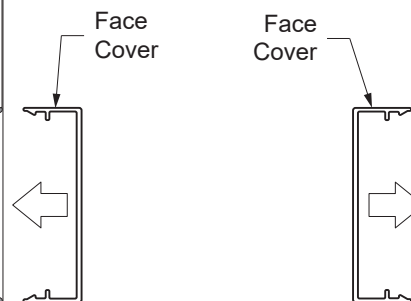

Detail 53

GLAZING**STEP 22
INSTALL INTERIOR GLAZING GASKETS**

The interior glazing gaskets must be installed prior to the glazing process.

-Using a small brush clean out any dirt that may have accumulated in the gasket reglets.

Vertical glazing gaskets must be installed first:

- Cut vertical glazing gaskets to Daylight Opening plus(+) 1/4" for each foot of length.
- Insert the gasket into the reglet at each end first, and then insert the gasket at the midpoint of the opening.
- Push the gasket into the reglet starting at the midpoint and work towards each end.

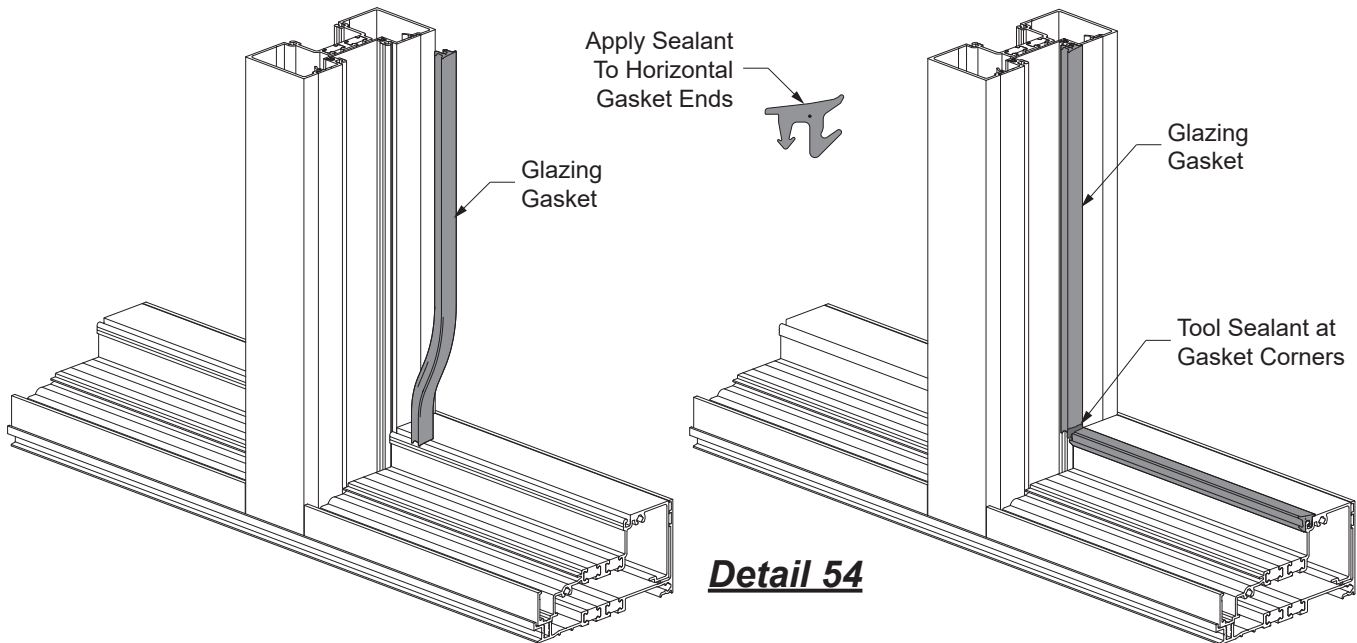

Install horizontal glazing gaskets next:

- Cut horizontal glazing gaskets to Daylight Opening plus(+) 1/4" for each foot of length.
- Apply sealant to each end of the horizontal glazing gasket prior to inserting into the reglet.
- Insert the gasket into the reglet at each end first and push each end tight against the vertical gasket.
- Then insert the gasket at the midpoint of the opening and push the gasket into the reglet starting at the midpoint and work towards each end.
- Tool the excess sealant at the gasket corners to ensure a watertight seal.

See **Detail 54**.

GLAZING

STEP 23 INSTALL GLASS

Determine the glass size:

Horizontal Glass Size = D.L.O. plus(+) 3/4"
Vertical Glass Size = D.L.O. plus(+) 3/4"

- Carefully install the glass into the opening: bring the lite up and into the deep pocket first and then rotate the other end in place.
- Carefully lift lite of glass, install setting blocks at quarter points of horizontal D.L.O. or according to engineering calculations.
- Make sure the glass is engaged with all setting blocks.

See **Detail 55**.

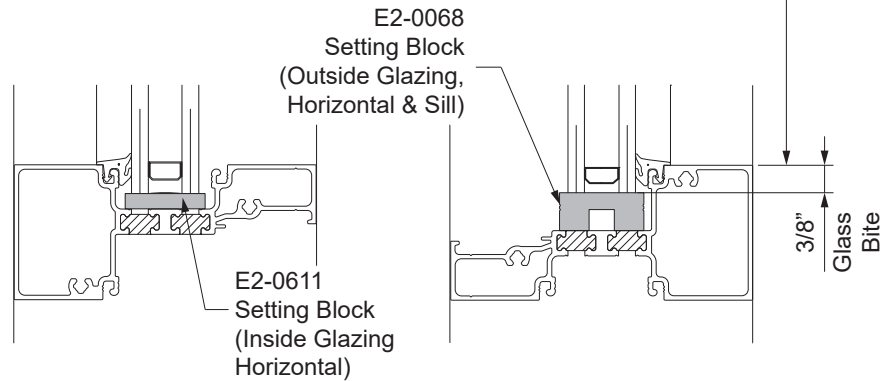
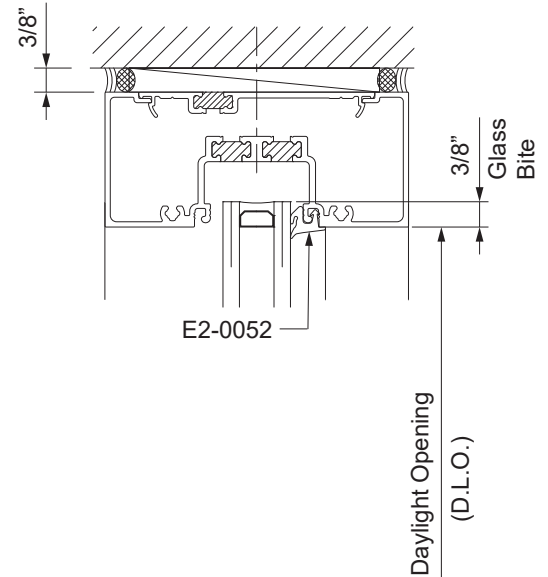

Detail 55

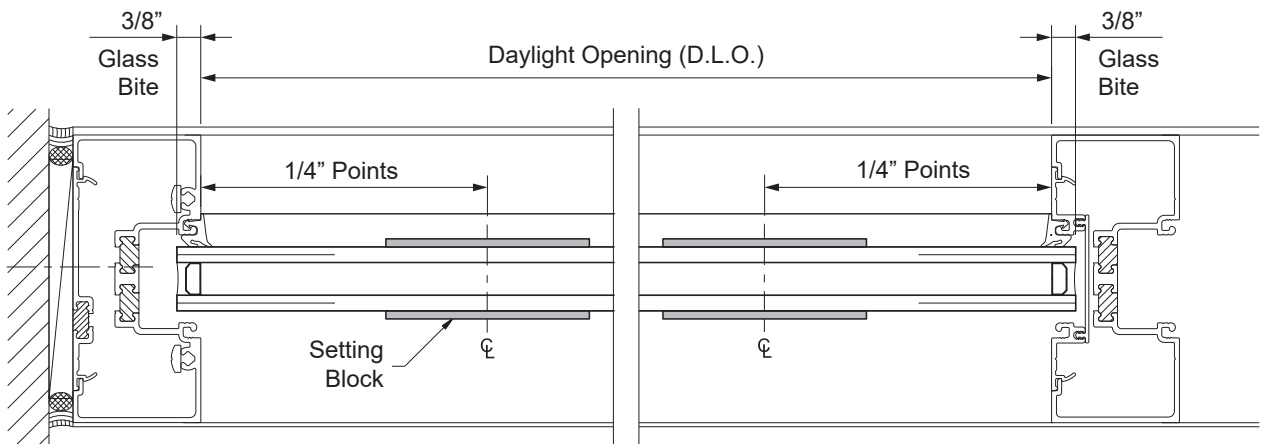

GLAZING

**STEP 24
INSTALL ANTI-WALK BLOCKS**

YES 45 XT frames require the installation of an anti-walk block, E2-0153, in the vertical deep glazing pocket of each lite centered along the daylight opening.

-Flatten the anti-walk block against the exterior surface of the glass and push it into the opening between the glass and the mullion until it is released into the glazing pocket.

See **Detail 56**.

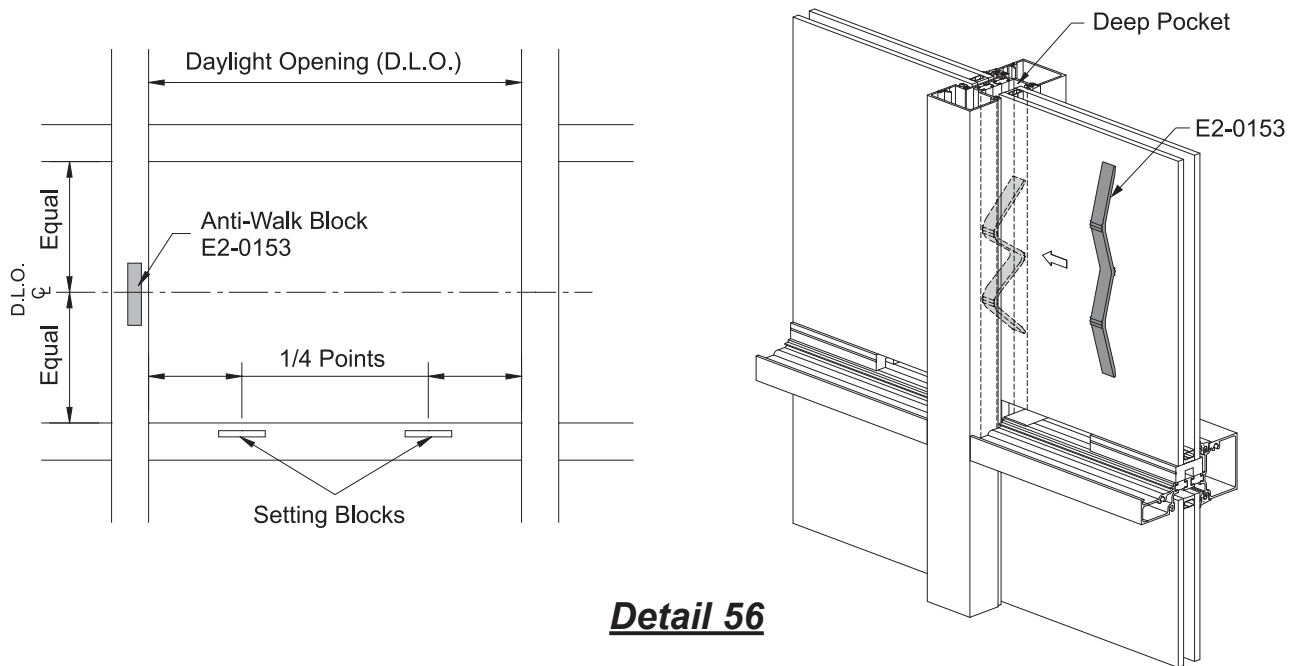

Detail 56

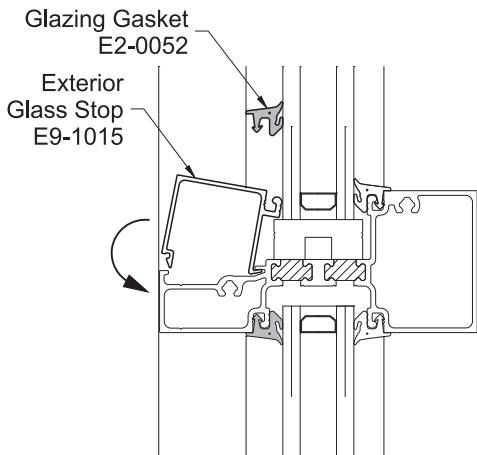

Detail 57

**STEP 25
INSTALL EXTERIOR GLASS STOPS
& GLAZING GASKETS**

-Snap the exterior glass stops into place as shown in **Detail 57**.

-Install the exterior glazing gaskets using the same technique described in **Step 22** on **Page-34**. Always install the vertical glazing gasket first.

Repeat **Steps 22 through 24** until all lites are installed.

GLAZING

STEP 25A INSTALL INTERIOR GLASS STOPS & GLAZING GASKETS

-Apply sealant to the ends of the interior glass stops as shown in **Detail 58**.
-Snap the exterior glass stops into place. Wipe off excess sealant.

-Install the interior glazing gaskets using the same technique described in **Step 22** on **Page 34**.
Always install the vertical glazing gasket first.

Repeat **Steps 22 through 24A** until all lites are installed.

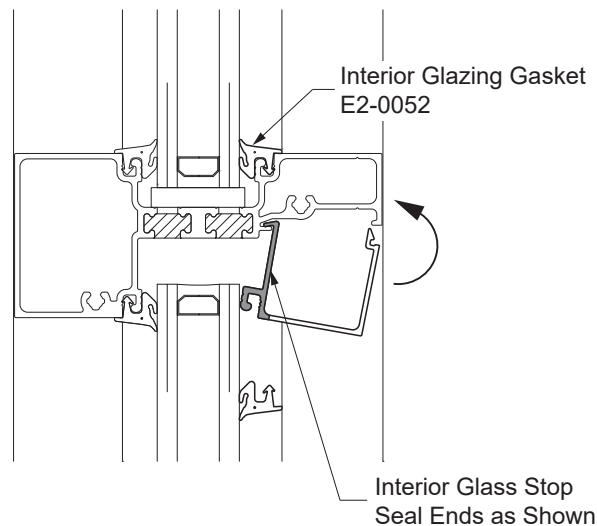

Detail 58



101 Marietta Street NW
Suite 2100
Atlanta, Georgia 30303
www.ykkap.com