

TABLE OF CONTENTS

Installation Notes	Page ii
Door Types	Page 1
Fabricate Transom Glazing Adaptors	Page 2
Fabricate Frame For Header	Page 2
Fabricate Transom Frame Header for Door Jambs	Page 3
Offset Pivot Frame Installation	Page 3
Butt Hinge Frame Installation	Page 4
Calculate Transom Glass Size	Page 5
Calculate Door Glass Size	Page 5
Install Smart Series Push/Pull Hardware	Page 6
Install Offset Pivot Door Into Frame	Page 6
Install Butt Hinge Door Into Frame	Page 6
Glaze the Door	Pages 7 & 8
Check Alignment of Door with Frame	Page 9
Adjust Weather Astragal for Pair of Doors	Page 9
Install Door Sweeps	Page 10
Install Optional Door Stop	Page 11

Installation Notes

1. Do not drop, roll or drag boxes of aluminum framing. Move and stack boxes with proper support to prevent distortion. If fork lifts are used be especially careful about striking the boxes when lifting or moving.
2. Store in a dry, out of the way area. If rain exposure, condensation or any water contact is likely, then all packaging material should be removed. Wet packaging materials will discolor and may stain aluminum finishes and paints.
3. All materials should be checked for quantity and quality upon receipt, YKK AP must be notified immediately of any discrepancies in shipment. Check to make sure that you have the required shims, sealants, supplies and tools necessary for the installation.
4. Carefully check the openings and surrounding conditions that will receive your material. Remember, if the construction is not per the construction documents, it is your responsibility to notify the general contractor in writing. Any discrepancies must be brought to the general contractor's attention before you proceed with the installation.
5. Gather your shop drawings, materials, packing list and this installation manual. Carefully review parts location, the sequence it goes therein when you glaze it and how you seal it. Installation instructions are of a general nature and may not cover every condition you encounter. The shop drawings and/or installation manuals were prepared specifically for the product.
6. Any material substitutions must be of equal or greater quality.
7. Make certain that material samples have been sent for compatibility testing for all manufacturer's sealants involved. Make certain that sealants have been installed in strict accordance with the manufacturer's recommendations and specifications.
8. Remember to isolate, in an approved manner, all aluminum from uncured masonry or other incompatible materials.
9. System-to-structure fasteners are not supplied by YKK AP. Fasteners called out on shop drawings are to indicate minimum sizes for design loading.
10. **Entrance frames and doors are to be installed plumb, square, level and true.**
11. If any questions arise concerning YKK AP products or their installation, contact YKK AP for clarification before proceeding.
12. YKK AP store front and/or curtain wall framing is typically completed before drywall, flooring and other products that may still be in process. Take the extra time to wrap and protect work produced.
13. Cutting tolerances are plus zero, minus one thirty second unless otherwise noted.
14. Check our website, www.ykkap.com, for the latest installation manual update prior to commencing work.

This manual applies to the door types listed below.

35HL LARGE MISSILE

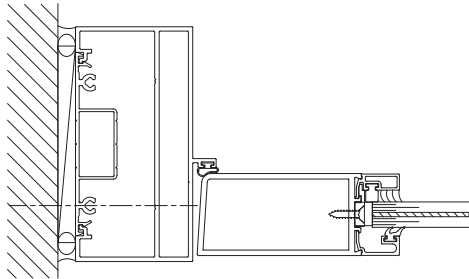

9/16" Glazing

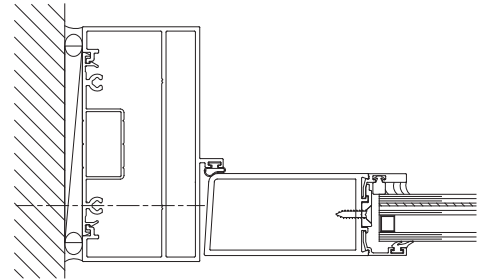

1" Glazing

35HL SMALL MISSILE

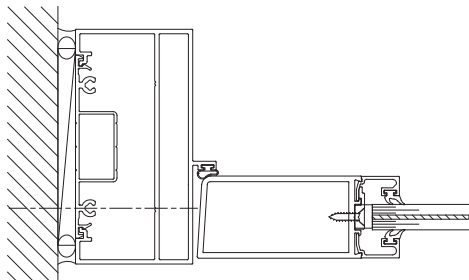

9/16" Glazing

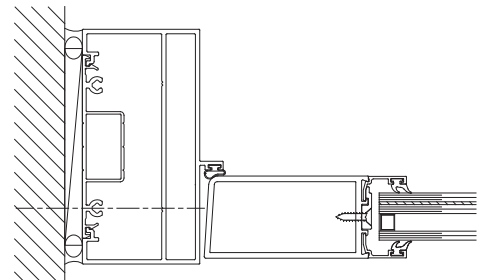

1" Glazing

50HL LARGE MISSILE

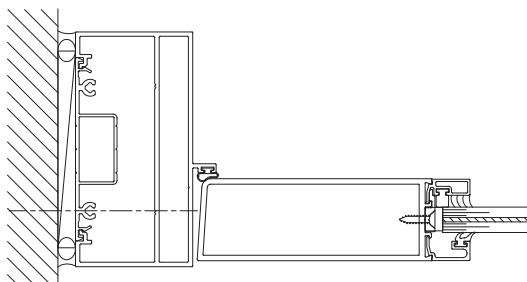

9/16" Glazing

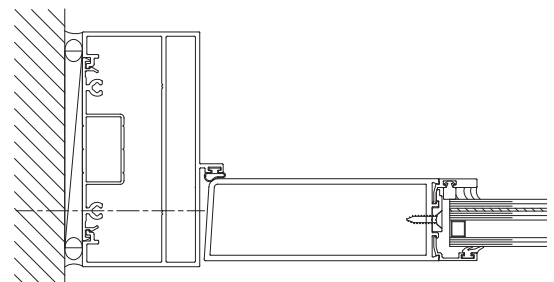

1" Glazing

50HL SMALL MISSILE

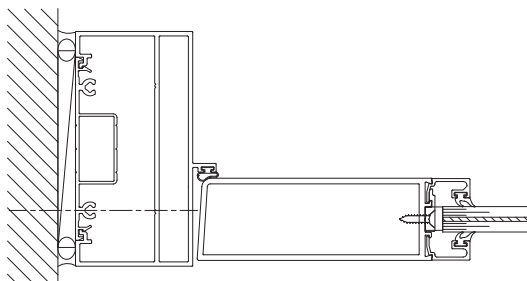

9/16" Glazing

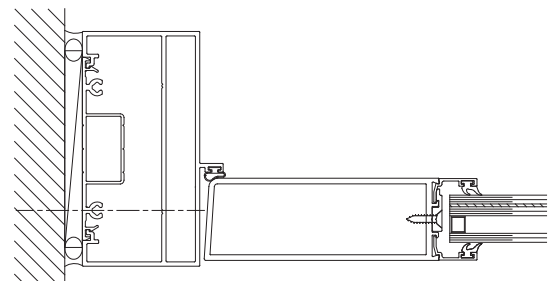

1" Glazing

STEP 1 FABRICATE TRANSOM GLAZING ADAPTORS (For non-transom frames, proceed directly to Step 3)

Measure the height of each masonry opening that is to receive a door frame. If there are several different frame heights, it will be necessary to label each frame.

- Deduct 3/8" from the height of the masonry opening to determine the frame size.
- Deduct an additional 2-1/2" from the top of frame. This will be the top of the transom frame adaptor.
- Mark the top of the transom bar. This will be the bottom of the transom frame adaptor.
- Cut the transom frame adaptor to the length determined from the top of the transom bar and 2-1/2" from the top of the frame.
- Fasten the transom adaptor to the door jamb using (2) FS-1010 TEK screws at 1-1/2" from each end of the transom glazing adaptor.

See **Detail 1**.

Note: Three FS-1010 screws may be required for the transom glazing adaptor if the professional engineer specifies.

STEP 2 FABRICATE FRAME FOR HEADER

- Measure down from the top of the frame dimension as noted in **Detail 2**.
- Mark the spot on each "Inner V-Groove" for the holes required to attach header.
- Drill a 0.236" diameter hole (#B drill bit) through both the web and the front of the jamb, at each location marked.

See **Detail 2**.

- Drill 1/2" diameter access holes in web only, centered on the first holes drilled, to permit the head of the fasteners to pass through the web.
 - Notch one end of the flat filler for the frame header as shown on **Detail 3**.
- This end will be fastened into the door jamb.

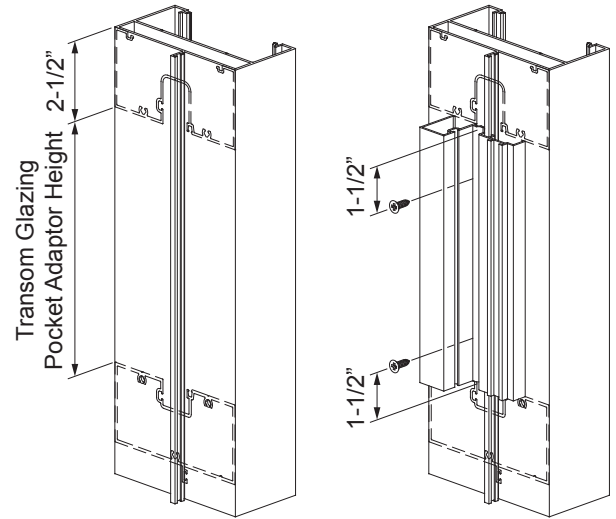

DETAIL 1

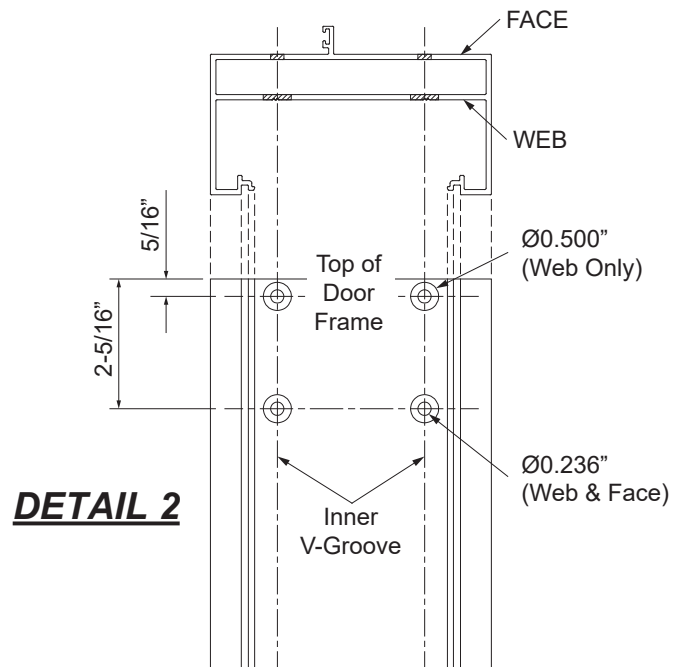

DETAIL 2

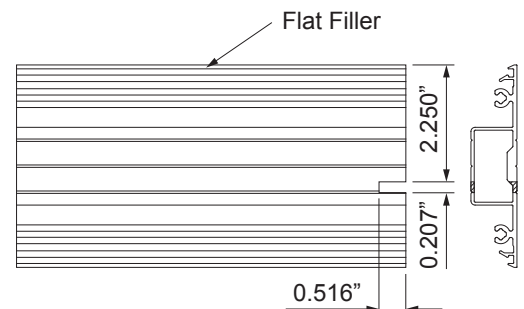

DETAIL 3

STEP 3 OFFSET PIVOT FRAME INSTALLATION

- Remove from the door carton, through the cut-out provided, the offset pivot frame portion packages.
 - Top Pivot Package: Accessories: (1) top pivot frame portion E1-0303.
Screws: (3) FM-1206 finish to match frame.
 - Bottom Pivot Package: Accessories: (1) bottom pivot frame portion: E1-0300(RH), E1-0301(LH).
(1) Plastic anchor plug.
Screws: (2) FM-1206 finish to match frame.
(2) FM-1206 mill finish.
- Remove from the frame carton the frame accessory package:
 - Singles and pairs: Accessories: (3) plastic anchor plugs, (2) setting blocks for transom lite: E2-0737 for 9/16" glass or E2-0134 for 1-5/16" glass.
Screws: (3) FC-1228, (7 or 14) PC-1216 (14 for transom).
 - Single door frames only: Accessories: (1) threshold clip E1-0307.
Screws: (2) FM-1206 to match frame, (2) FM-1206 mill finish.

- Attach bottom pivot and threshold clips to frame.
- Attach top pivot frame portion to the transom bar.
- Assemble frame as shown.

See **Detail 4**.

Install the frame into the opening:

- Anchor bottom pivot to the opening.
- Shim if required.
- Attach the threshold to the frame set in bed of sealant.
- Shim and anchor frame so that it is plumb, square, level, and true.
- Caulk the perimeter of the frame with sealant.

Glaze the transom lite:

(See **Page 5** to calculate Transom Glass Sizes)

- Install interior glazing gasket in the transom.
- Install setting blocks at quarter points.
- Carefully install the transom lite.
- Snap into place the exterior transom glass stop.
- Install exterior gasket.

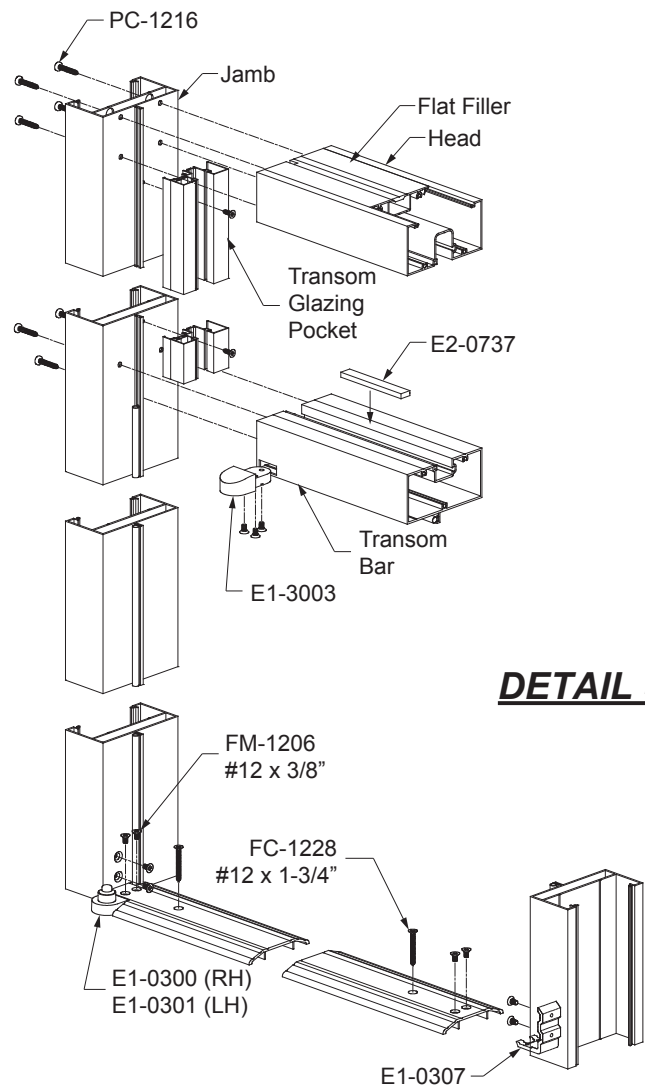

DETAIL 4

STEP 3 BUTT HINGE FRAME INSTALLATION

-Remove from the door carton, through the cut-out provided, the accessory package.

Accessories: (2) threshold clips E1-0307, (3) plastic anchor plugs, (2) setting blocks for transom lites: E2-0737 for 9/16" glass or E2-0134 for 1-5/16" glass.

Fasteners: (3) FC-1228 FHSMS, (8) FM-1206 (4 to match frame & 4 mill finish, and (7 or 14) PC-1216 fasteners (14 for transom frames).

-Attach the threshold clips to the frame.

-Assemble frame as shown.

See **Detail 5**.

Install the frame into the opening:

-Attach the threshold to the frame set in bed of sealant.

-Shim and anchor frame so that it is plumb, square, level, and true.

-Caulk the perimeter of the frame with sealant.

Glaze the transom lite:

(See **Page 5** to calculate Transom Glass Sizes)

-Install interior glazing gasket in the transom.

-Install setting blocks at quarter points.

-Carefully install the transom lite.

-Snap into place the exterior transom glass stop.

-Install exterior gasket.

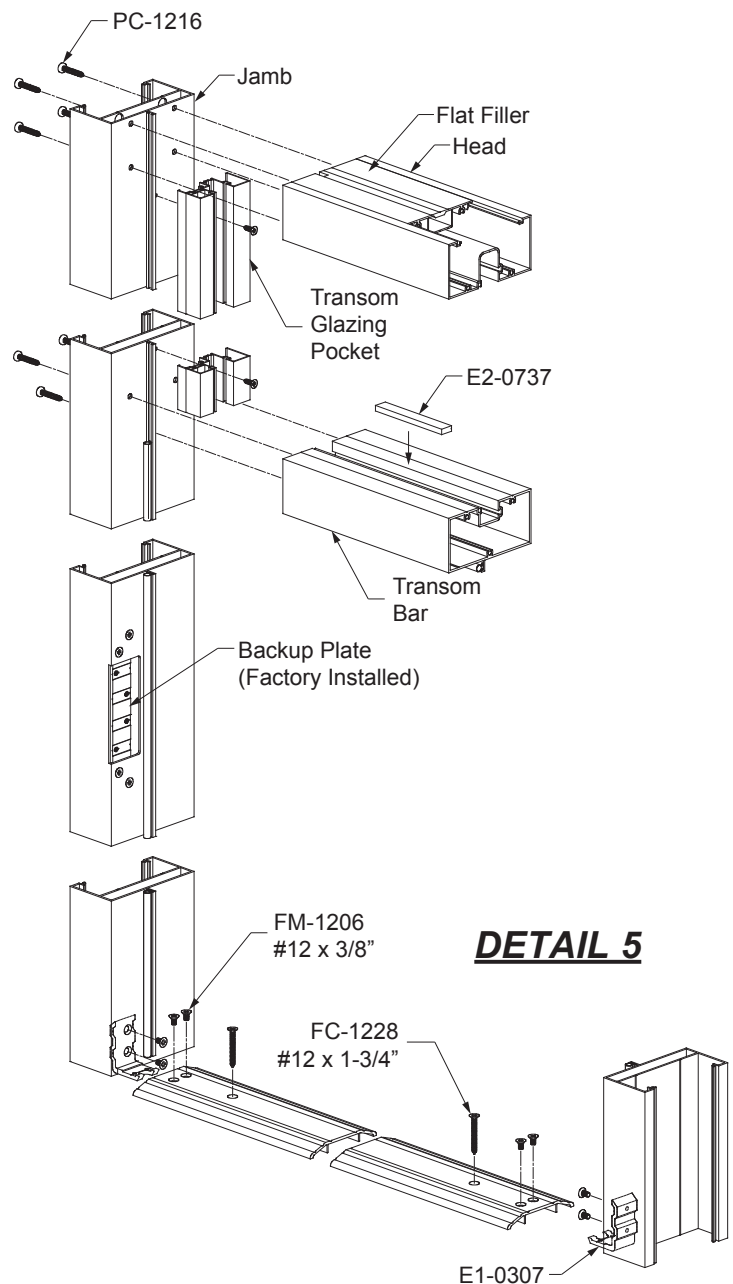

Calculate Transom Glass Sizes:

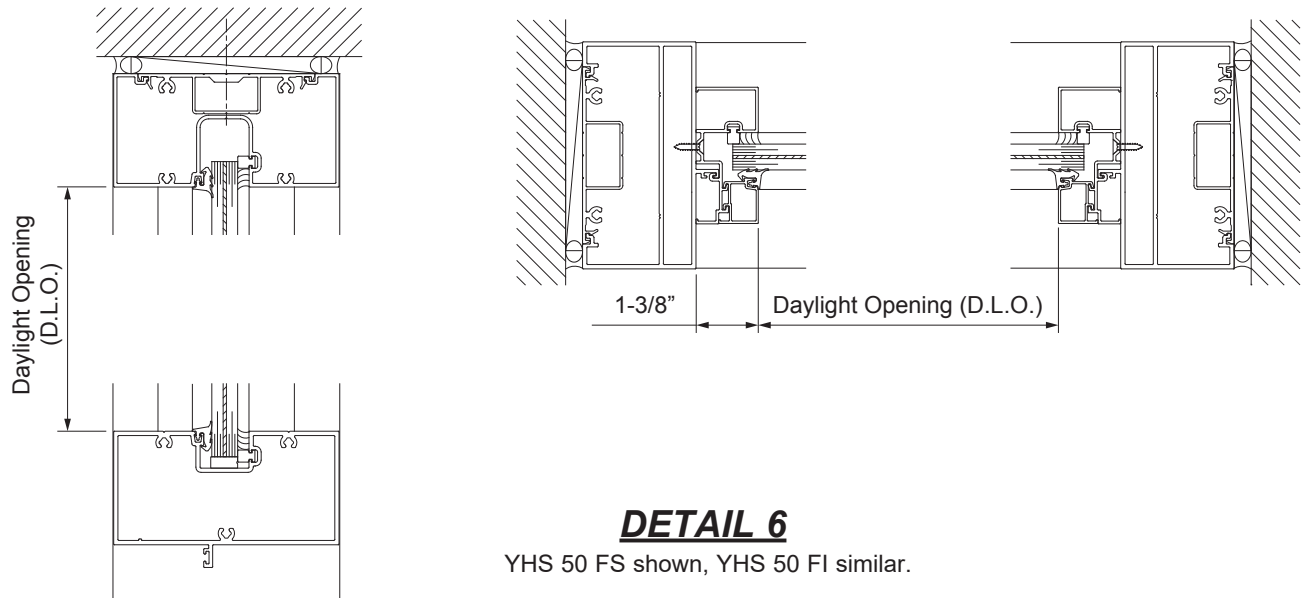

Transom Glass Size Formula

TYPE	YHS 50 FS/FI
Width for Single Glass	D.L.O. +(plus) 1-1/8"
Height for Single Glass	D.L.O. +(plus) 1-1/8"
Width for Insulating Glass	D.L.O. +(plus) 1-1/8"
Height for Insulating Glass	D.L.O. +(plus) 1-1/8"

Calculate Door Glass Sizes:

Model 35HL/50HL Door

Threshold (1/2") Allowance Included

Door Opening Size	35HL Medium Stile	50HL Wide Stile
Height 8" Bottom Rail	D.O. -(minus) 13-1/8"	D.O. -(minus) 14-3/16"
Height 10" Bottom Rail	D.O. -(minus) 15-3/16"	D.O. -(minus) 16-1/4"
Width Single - Butt Hinge	D.O. -(minus) 7-5/8"	D.O. -(minus) 10-5/8"
Width Single - Cont. Hinge	D.O. -(minus) 7-7/8"	D.O. -(minus) 10-7/8"
Width Pair - Butt Hinge	D.O. ÷ 2 -(minus) 7-5/8"	D.O. ÷ 2 -(minus) 10-5/8"
Width Pair - Cont. Hinge	D.O. ÷ 2 -(minus) 7-7/8"	D.O. ÷ 2 -(minus) 10-7/8"

STEP 4 INSTALL SMART SERIES PUSH/PULL HARDWARE

Attach pull handle:

- Remove from the door carton the push/pull hardware and accessory package.
- Fasten the pull handle to the lock stile with the 2-1/2" shoulder bolt at the top and with the 2-3/4" oval head machine screw at the bottom. Make sure the washer is properly seated under the screw head.

Attach push bar:

- Attach the end cap to the pivot stile with the FM-2512 3/4" machine screw.
- Insert the straight end of the push bar into the end cap and swing the curved end onto the shoulder bolt head. Tighten the set screws at each end of the push bar using a 1/8" Allen wrench.

See **Detail 8**.

Note: For center pivot doors, push bars are installed on both sides of the doors; attach shoulder bolts on both stiles and follow the instructions above to attach push bars. Repeat steps for the other side.

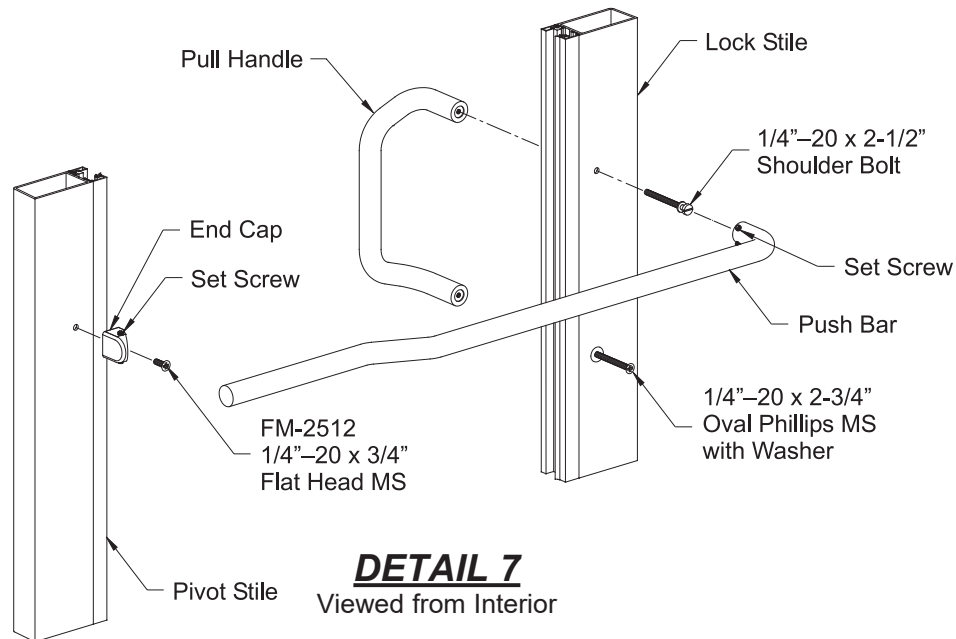

STEP 5 INSTALL OFFSET PIVOT DOOR INTO FRAME

- Set the door down onto the bottom pivot of the frame.
- Compress the retractable pivot pin in the top pivot and set the door up into position so the pivot pin engages the frame pivot.

STEP 5A INSTALL BUTT HINGE DOOR INTO FRAME

- Remove from the door carton the package of eight fasteners that will attach the butt hinges to the backup plates in the frame.
- Carefully align the holes in the butt hinge with the holes in the back up plates and fasten the door to the frame. Completely support the door during this step.

STEP 6 GLAZE THE DOOR

Trim the glazing gaskets.

For small missile glazing:

- Trim glazing gasket leaving 1/8" excess at each end.

For large missile glazing

- Install all structural silicone spacers, E2-0084, in all horizontals and verticals **prior** to frame assembly.
- Horizontal silicone spacers are to be cut to D.L.O. + 7/8" and must be notched as shown in **Detail 8**.
- Vertical silicone spacers are to be cut to the full length of the vertical mullion and are not notched.

Caution: Be careful not to stretch silicone spacers when installing.

Insert the gaskets into both the interior and exterior glass stops.

Install interior glass stops.

- Install the vertical glass stop first by engaging the toe ① first then snapping in the heel ②.

See **Detail 9a**.

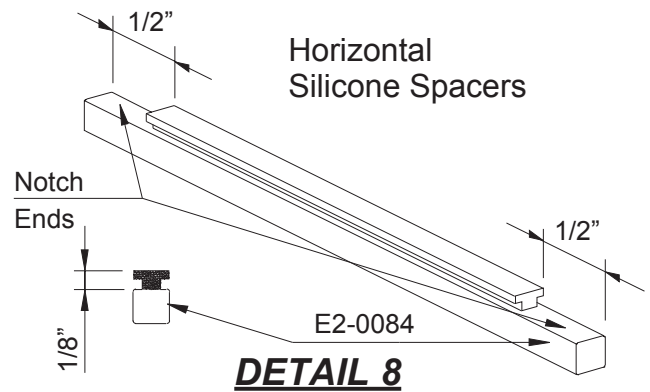

DETAIL 8

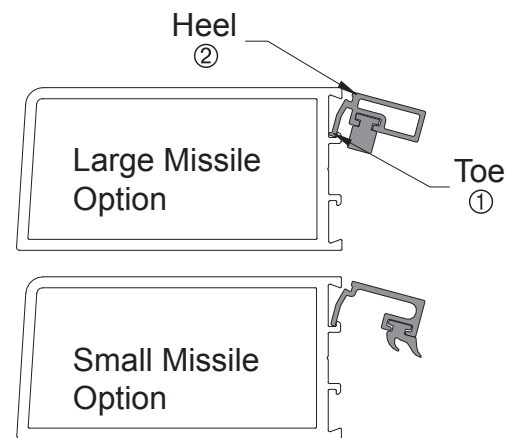

DETAIL 9a

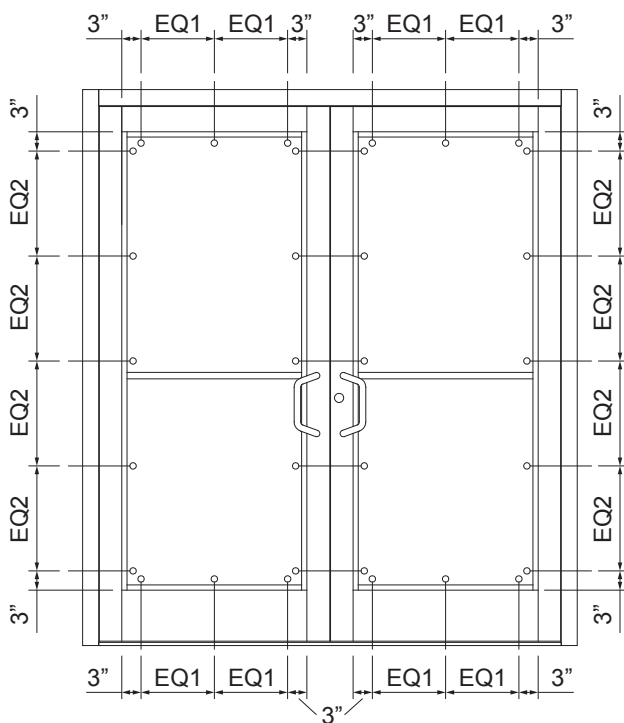

DETAIL 10

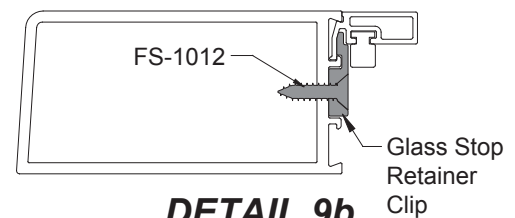

DETAIL 9b

35HL shown, 50HL similar.

-Center the horizontal glass stops and install.

-Install glass stop retainer clip using FS-1012 TEK screws, 5 on each vertical glass stop and 3 on each horizontal glass stop, located 3" from each end of the glass stop and evenly spaced thereafter. See **Detail 9b** and **Detail 10**.

STEP 6 GLAZE THE DOOR (Continued)

-Carefully install the door lite onto the factory installed corner blocks.
See **Detail 11a**.

Install the exterior glass stops.

- Install the vertical glass stop first by engaging the toe ① first then snapping in the heel ②.
- Center the horizontal glass stops and install.

See **Detail 11b**.

Note: for small missile option, glazing process is complete at this point. See **Detail 11d**.

For large missile only:

-Apply masking tape to the aluminum and glass according to **Detail 11c**.

Note: Apply tape to the glass 1/8" away from the aluminum to provide a 30° bevel.

- Apply Dow Corning® 995 structural silicone sealant from the bottom to the top of joint.
- Use positive pressure so that sealant completely fills the cavity between glass and aluminum.
- Using a 30° nylon beveled spatula, or other non-scratching implement, tool the structural silicone sealant immediately after running the joint. Exert positive pressure while tooling sealant to ensure that the silicone makes complete contact with all surfaces.

Note: Be careful not to remove too much silicone. The finished joint should be 30° beveled around the glass.

-Immediately remove masking tape while wet; do not allow silicone to skin. Masking tape must be removed within 10 minutes of tooling.

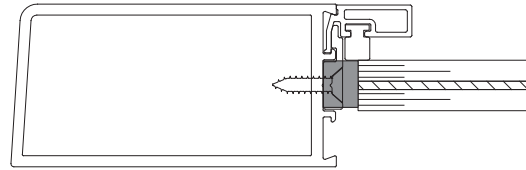

DETAIL 11a

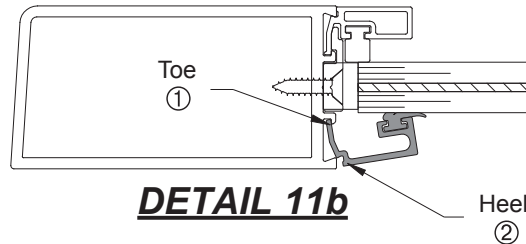

DETAIL 11b

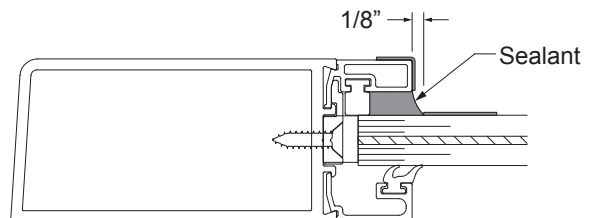

DETAIL 11c

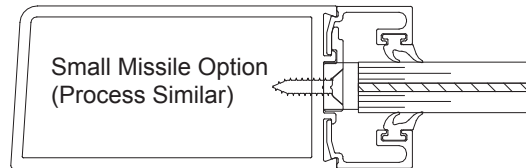

DETAIL 11d

35HL shown, 50HL similar.

STEP 7 CHECK ALIGNMENT OF DOOR WITH FRAME (For Offset Pivots)

-Check the alignment of the door.
-Align the stile opposite the pivot stile by turning the screw located in the top rail:

- Clockwise to raise the corner.
- Counter-clockwise to lower the corner.

See **Detail 12**.

-Align the pivot stile by adjusting the screw in the bottom pivot.

-Unscrew the cap on top of the pivot and adjust the screw inside the pivot with a 3/16" Allen wrench:

- Clockwise to raise the corner.
- Counter-clockwise to lower the corner.

-Replace the cap on top of the pivot.

See **Detail 13**.

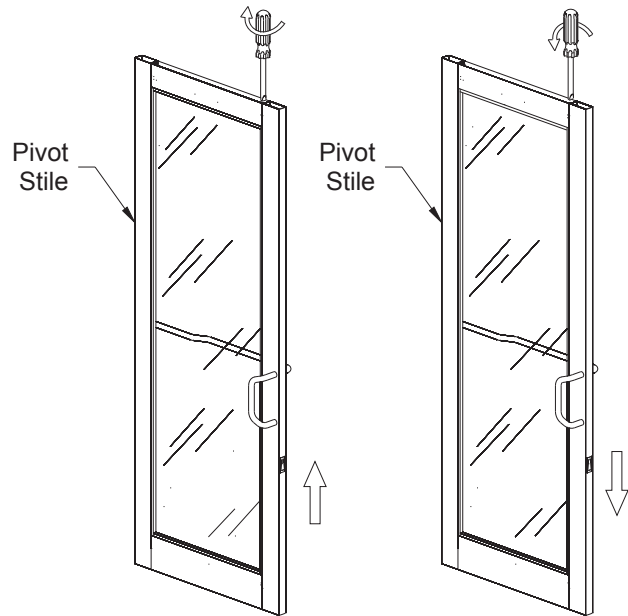

DETAIL 12

DETAIL 13

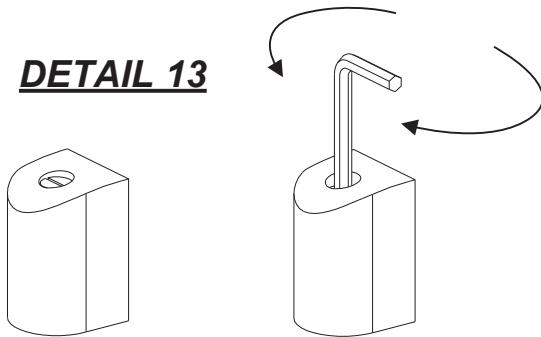

Clockwise = Raise
Counter Clockwise = Lower

STEP 7 CHECK ALIGNMENT OF DOOR WITH FRAME (For Butt Hinges)

-Adjust the alignment of the door by turning the screw located in the top rail:

- Clockwise to raise the corner.
- Counter-clockwise to lower the corner.

See **Detail 12**.

STEP 8 ADJUST WEATHER ASTRAGAL FOR PAIR OF DOORS

-Adjust the weather astragal by turning the adjustment screws located along the meeting stile cover of the active leaf:

- Clockwise to increase the distance between leaves.
- Counter clockwise to reduce the clearance between leaves.

See **Detail 14**.

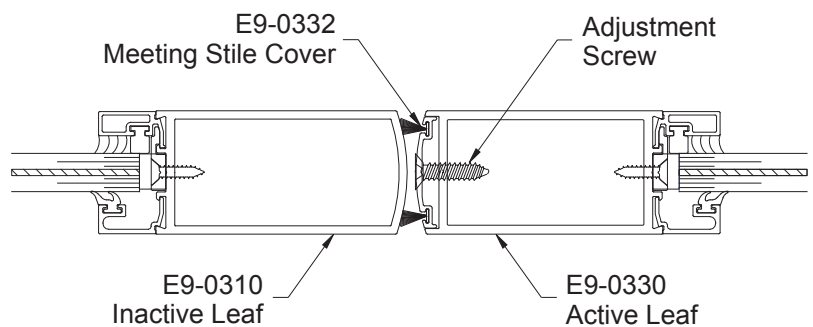

35HL shown, 50HL similar.

DETAIL 14

**STEP 9
INSTALL DOOR SWEEP**

- Door sweeps help the weathering performance of the door and are designed to be attached to the interior face of the bottom rail.
- Transfer the location of each slot in the door sweep base, E9-0347, to the interior surface of the bottom rail:
 - Center the door sweep base on the bottom rail of the door.
 - Align the bottom edge of the door sweep base with the bottom edge of the bottom rail.
 - Mark the center of each slot on the bottom rail.
- Drill a 0.141" diameter hole (#28 drill bit) at each location marked.
- Attach the door sweep base to the bottom rail with four PC-0808 fasteners; do not completely tighten the fasteners. Check the contact of the door sweep gasket, E2-0067, with the threshold. The door sweep gasket must make full contact with the threshold to obtain the full benefit of the door sweep.
- Tighten all of the door sweep fasteners.
- Use a wood block and mallet to snap the door sweep cover, E9-0348, onto the base.

See **Detail 15**.

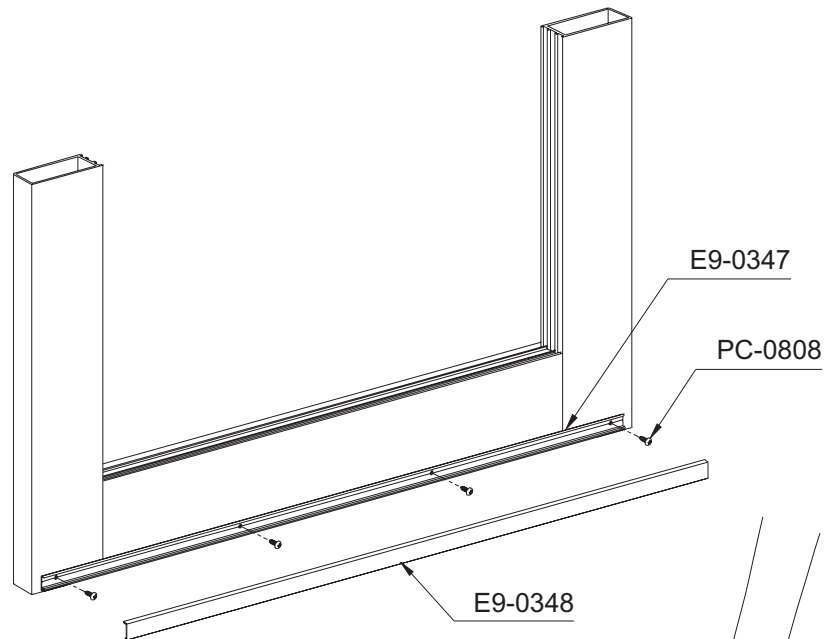

DETAIL 15
Viewed from Interior

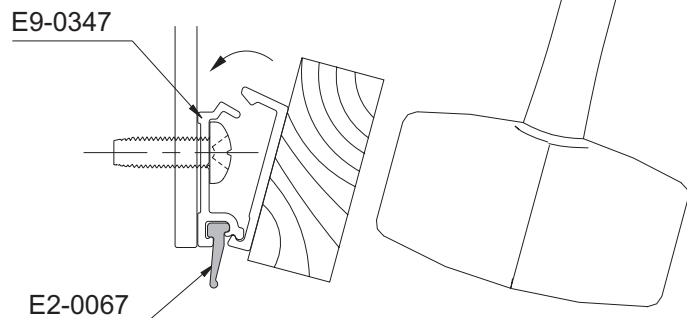

STEP 9 INSTALL OPTIONAL DOOR STOP

Note: Optional door stop cannot be used with an interior door sweep.

- Center the door stop E1-1138 at the threshold.
- Mark the center for the three screw holes on the threshold.
- Drill a 0.161" diameter tap hole at each location marked.
- Attach the E1-1138 door stop to the threshold using (3) FC-1012 fasteners.

See **Detail 16**.

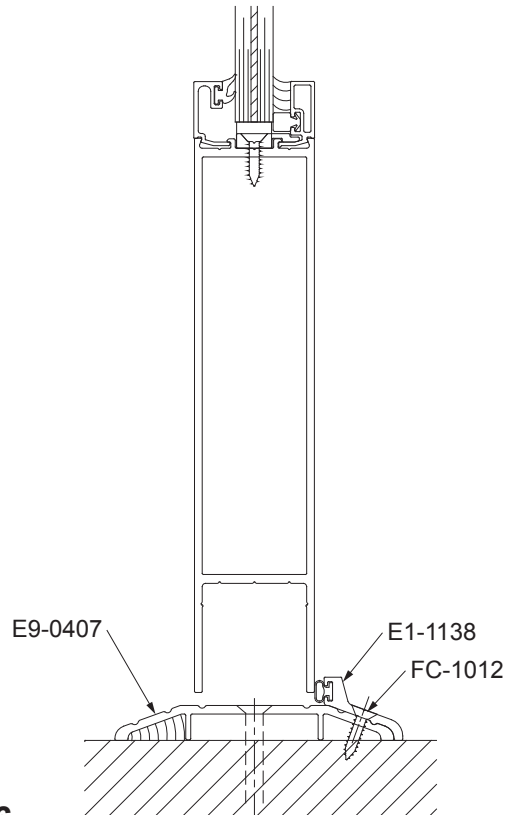

DETAIL 16
35HL shown, 50HL similar

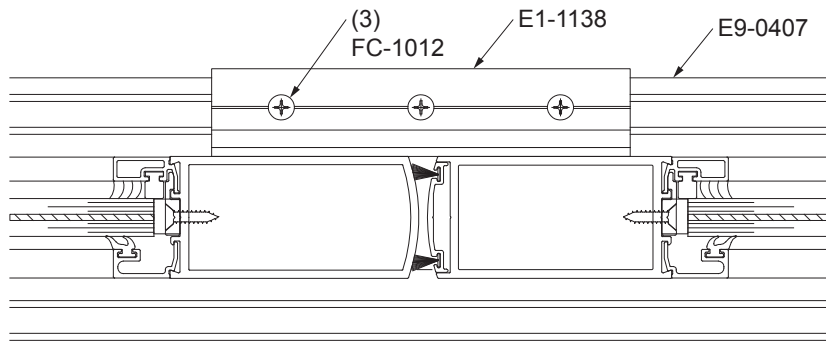



101 Marietta Street NW
Suite 2100
Atlanta, Georgia 30303
www.ykkap.com